



YENYO

6A05G THRU 6A10G

Glass Passivated Standard Rectifier

Features

- * Low forward voltage drop
- * High current capability
- * Low reverse leakage current
- * High surge current capability

Mechanical Data

- * Case: Molded plastic P600
- * Epoxy: UL 94V-0 rate flame retardant
- * Terminals: Solderable per MIL-STD-202 method 208 guaranteed
- * Polarity: Color band denotes cathode end
- * Mounting position: Any
- * Weight: 2.15 gram

**Voltage Range 50 to 1000 V
Current 6.0 Ampere**

P600

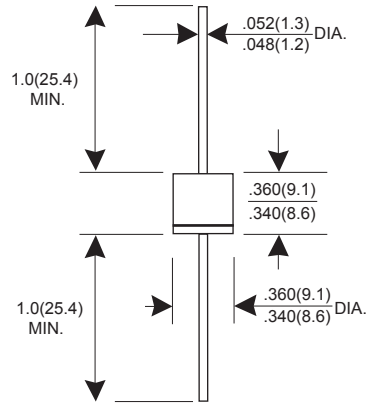

Dimensions in inches and (millimeters)

MAXIMUM RATINGS AND ELECTRICAL CHARACTERISTICS

Rating at 25°C ambient temperature unless otherwise specified.

Single phase, half wave, 60Hz, resistive or inductive load.

For capacitive load, derate current by 20%.

PARAMETER	SYMBOL	6A05G	6A1G	6A2G	6A4G	6A6G	6A8G	6A10G	UNIT
Maximum Recurrent Peak Reverse Voltage	VRRM	50	100	200	400	600	800	1000	V
Maximum RMS Voltage	VRMS	35	70	140	280	420	560	700	V
Maximum DC Blocking Voltage	VDC	50	100	200	400	600	800	1000	V
Maximum Average Forward Rectified Current $T_L=50^\circ\text{C}$	$I_{(AV)}$	6.0							A
Peak Forward Surge Current, 8.3ms single Half sine-wave superimposed on rated load (JEDEC method)	IFSM	250							A
Maximum Instantaneous Forward Voltage @ 6.0 A	V _F	1.1							V
Maximum DC Reverse Current @ $T_J=25^\circ\text{C}$ At Rated DC Blocking Voltage @ $T_J=125^\circ\text{C}$	I _R	10.0 250							uA uA
Typical junction Capacitance (Note 1)	C _J	100							pF
Typical Thermal Resistance (Note 2)	R _{θJA}	100							°C/W
Operating Junction and Storage Temperature Range	T _J , T _{STG}	-55 to +150							°C

NOTES : (1) Thermal Resistance junction to lead.

(2) Measured at 1.0 MHz and applied reverse voltage of 4.0 Volts DC.

RATINGS AND CHARACTERISTIC CURVES 6A05G THRU 6A10G

FIG.1 - FORWARD CURRENT DERATING CURVE

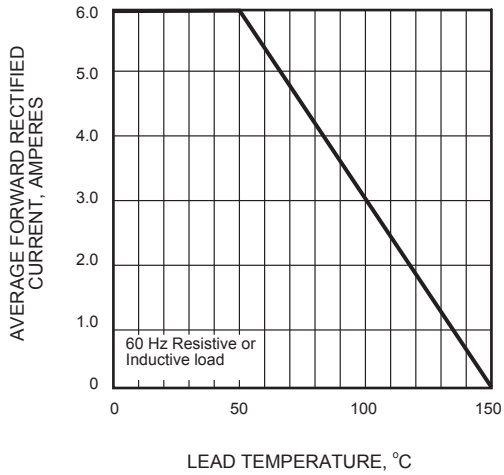

FIG.2 - MAXIMUM NON-REPETITIVE PEAK FORWARD SURGE CURRENT

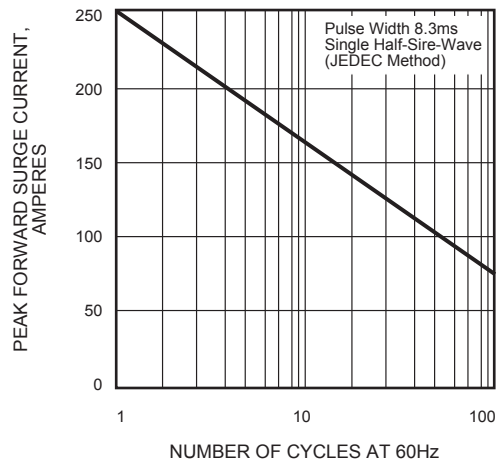

FIG.3 - TYPICAL INSTANTANEOUS FORWARD CHARACTERISTICS

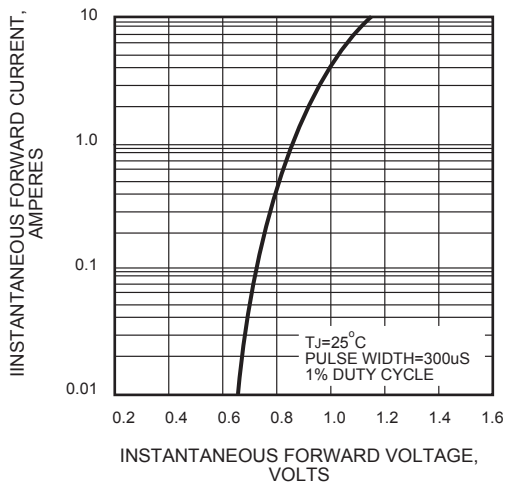

FIG.4 - TYPICAL REVERSE CHARACTERISTICS

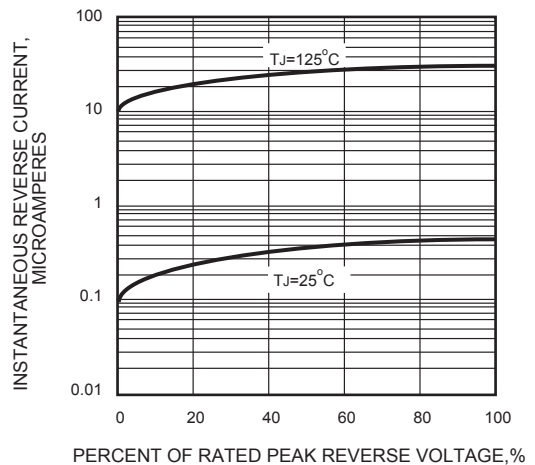

FIG.5 - TYPICAL JUNCTION CAPACITANCE

