

SIEMENS

SIPART PS2

6DR50xx

www.DataSheet4U.com 6DR51xx

6DR52xx

6DR53xx

Edition 10/2006

Manual

Electropneumatic Positioner for
Linear and Part-Turn Actuators

Copyright © Siemens AG 2006 All rights reserved

Disclaimer of Liability

The reproduction, transmission or use of this document or its contents is not permitted without express written authority. Offenders will be liable for damages. All rights, including rights created by patent grant or registration of a utility model or design, are reserved.

Siemens AG
Bereich Automatisierungs- und Antriebstechnik
Geschäftsgebiet Prozessinstrumentierung- und Analytik
D-76181 Karlsruhe

We have checked the contents of this manual for agreement with the hardware and software described. Since deviations cannot be precluded entirely, we cannot guarantee full agreement. However, the data in this manual are reviewed regularly and any necessary corrections included in subsequent editions. Suggestions for improvement are welcomed.

© Siemens AG 2006
Technical data subject to change.

www.DataSheet4U.com

Trademarks

SIMATIC, SIPART, SIREC, SITRANS are registered trademarks of Siemens AG.

Third parties using for their own purposes any other names in this document which refer to trademarks might infringe upon the rights of the trademark owners.

Contents

0	Information for the Operator	5
0.1	General information	5
0.2	Classification of Safety Related Notices	6
0.3	Qualified Personnel	7
0.4	Use as intended	9
0.5	Technical Documentation	9
0.6	Warranty Information	9
0.7	Delivery Notes	10
0.8	Standards and Regulations	10
1	Introduction	11
1.1	General information about the positioner	11
2	Design and Method of Operation	15
2.1	Overview	15
2.2	Design name plate	17
2.3	Instrument Components	17
2.3.1	Motherboard	18
2.3.2	Electrical Connections	18
2.3.3	Pneumatic Connections	19
2.3.4	Mounting Kit	22
2.3.5	Purge air switching (not in the explosion proof version)	22
2.3.6	Restrictors	22
2.4	Method of Operation	23
2.5	HART-function	26
2.6	State as supplied	26
2.7	Installation of options modules	27
2.7.1	Installation of options modules in normal and intrinsically safe versions	27
2.7.2	Installation of options modules in explosion proof version	29
2.7.3	ly-module	31
2.7.4	Alarm module	32
2.7.5	SIA module	33
2.7.6	Mechanical limit switch module	35
2.7.7	EMC filter module	38
2.7.8	Accessories	39
3	Preparing for Operation	41
3.1	Instrument identification (type key)	41
3.2	Dimensional drawings	41
3.3	Assembly	43
3.3.1	Instructions for using positioners in a wet environment	44
3.3.2	Instructions for using positioners which are exposed to strong accelerations or vibrations	46
3.3.3	Mounting kit "linear actuator" 6DR4004-8V and 6DR4004-8L	49
3.3.4	Assembly procedure (see figure 3-7, page 51)	50

3.3.5	Mounting kit “part-turn actuator” 6DR4004-8D	52
3.3.6	Assembly procedure (see figure 3-8 and figure 3-9)	53
3.4	Electrical Connection	57
3.4.1	Connection in non-intrinsically safe and explosion proof version	59
3.4.2	Connection in intrinsically safe version	62
3.4.3	Connection in type of protection “n” version	68
3.5	Pneumatic Connection	71
3.6	Commissioning	72
3.6.1	Preparations for linear actuators	73
3.6.2	Automatic initialization of linear actuator	74
3.6.3	Manual initialization of linear actuator	76
3.6.4	Preparations for part-turn actuator	79
3.6.5	Automatic initialization of part-turn actuator	79
3.6.6	Manual initialization of part-turn actuators	81
3.6.7	Automatic initialization (structograms)	82
3.7	Copying initialization data (positioner exchange)	87
4	Operation	89
4.1	Display	89
4.2	Input keys	89
4.3	Operating modes	92
4.4	Parameters	95
4.5	Diagnostics	122
4.5.1	Diagnostic display	122
4.5.2	Meaning of the diagnostic values	123
4.5.3	Online diagnostics	131
4.5.4	Fault correction	136
4.6	Meaning of the other display text	139
4.7	Optimizing the controller data	143
5	Service and Maintenance	145
6	Technical Data	147
7	Scope of Delivery	153
7.1	Scope of delivery of standard controller	154
7.2	Scope of delivery of options	154
7.3	Scope of delivery of accessories	155
7.4	List of Spare Parts	156
8	Index	158
9	Appendix	160
9.1	Literature and catalogs	160

Information for the Operator

0

Dear customer,

Please read this manual before starting work!

It contains important information and data which, when observed, ensure full availability of the equipment and save service costs. This simplifies handling of this control instrument considerably and provides accurate measuring results.

You have purchased an instrument which can be installed in various configurations:

- SIPART PS2 **without** Ex-protection in a metal- or plastic housing.
- SIPART PS2 **with** EEx ia/ib-protection in a metal- or plastic housing.
- SIPART PS2 EEx d **in a** pressurized explosion proof housing

This manual takes each of these possibilities into consideration. Any differences between the devices are indicated specially.

Scope of delivery, see chapter 7, page 153.

0.1 General information

The product described in this manual left the factory in a perfectly safe and tested condition. To maintain this condition and to achieve perfect and reliable operation of this product, it must only be used in the way described by the manufacturer. Successful and safe operation of this equipment is dependent on proper handling, installation, operation and maintenance.

This manual contains the information required for use as intended of the product it describes. It is addressed to technically qualified personnel specially trained or having relevant knowledge of instrumentation and control technology, hereafter called automation technology.

Familiarity with and proper technical observance of the safety notes and warnings contained in this manual are essential for safe installation and commissioning and for safety in operation and maintenance of the product described. Only qualified personnel as defined in Chapter 0.3 has the necessary specialist knowledge to interpret the general safety notes and warnings given in this document in specific cases and to take the necessary action.

The documentation supplied with the instrument is listed in Chapter 0.5.

This manual is not a permanent part of the scope of supply. For reasons of clarity, it does not contain every detail about every version of the product described and cannot take every eventuality in installation, operation, maintenance and use in systems into account. If you require further information or if problems occur that have not been dealt with in sufficient detail in this document, please request the required information from your local Siemens office or the office responsible for you.

Functionality, commissioning and operation are described in this manual.

Please pay special attention to the **Warning and Note** texts. These are separated from the remaining text by horizontal lines and specially marked with symbols (see Chapter 0.2).

0.2 Classification of Safety Related Notices

This manual contains notices which you should observe to ensure your own personal safety, as well as to protect the product and connected equipment. These notices are highlighted in the manual by a warning triangle and are marked as follows according to the level of danger:



DANGER

indicates an imminently hazardous situation which, if not avoided, **will** result in death or serious injury.



WARNING

indicates a potentially hazardous situation which, if not avoided, **could** result in death or serious injury.



CAUTION

used with the safety alert symbol indicates a potentially hazardous situation which, if not avoided, may result in minor or moderate injury.

CAUTION

used without the safety alert symbol indicates a potentially hazardous situation which, if not avoided, may result in property damage.

NOTICE

indicates a potential situation which, if not avoided, may result in an undesirable result or state.



NOTE

highlights important information on the product, using the product, or part of the documentation that is of particular importance and that will be of benefit to the user.

0.3 Qualified Personnel

The result of unqualified intervention in the instrument or nonobservance of the warnings given in this manual or on product labels can be severe personal injury and/or serious material damage. Therefore only properly qualified personnel must make changes and settings in the instrument.

For the purpose of the safety information in this manual and on the product labels, qualified personnel are those who

- in the case of ex-proof equipment, are trained, instructed or authorized to perform work on electrical circuits of equipment subject to explosion hazard.
- if they are configuration personnel, are familiar with the safety concepts of automation technology
- if they are operating personnel, have been instructed in the handling of automation equipment and know the content of this manual relating to operation
- if they are commissioning and/or service personnel, are trained to repair such automation equipment and authorized to energize, de-energize, clear ground and tag circuits and equipment according to safety engineering standards.
- and instructed additionally in first aid



WARNING

The instrument must only be installed and commissioned by qualified personnel.

The device may be used solely for the purposes described in this manual.

The instrument is designed for connection to functional and safety extra low voltage.

Electrical safety depends only on the power supply equipment.

Pneumatic actuators exert considerable positioning forces. The safety precautions of the actuator used must therefore be scrupulously observed during installation and commissioning in order to prevent injuries.

We explicitly draw your attention to the necessity of observing safety regulations regarding operation in zones subject to explosion hazard, if applicable.

The specifications of the examination certificate valid in your country must be observed. Laws and regulations valid in your country must be observed for the electrical installation in explosions hazardous areas. In Germany these are for example:

- Working reliability regulations
- Regulations for installing electrical equipment in hazardous areas, DIN EN 60079-14 (in the past VDE 0165, T1).

It should be checked whether the available power supply, insofar as this is required, is compliant with the power supply specified on the rating plate and specified in the examination certificate valid in your country.

Take care to avoid electrostatic discharges within the hazardous area, such as can arise if a dry cloth is used to clean the positioner in the plastic housing.

Devices with the protection type “flameproof enclosure” may only be opened when the power is off.



WARNING

Devices with the protection type “intrinsically safe” lose their certification as soon as they are operated with circuits that do not conform to the specifications laid down in the examination certificate valid in your country.

The successful and safe operation of this equipment is dependent upon its proper handling, installation, operation and maintenance.

**WARNING**

The device may not be operated while the leaflets are in the housing.

0.4 Use as intended

Use as intended for the purpose of this manual means that this product must only be used for the applications described in the technical description (see also Chapter 3 of this manual).

The product described in this manual has been developed, manufactured, tested and documented observing the relevant safety standards. If the handling rules and safety information for configuration, installation, use as intended and maintenance are observed, there is normally no danger with regard to material damage or for the health of personnel. Extra low voltages that are connected must be fed in by safe isolation.

0.5 Technical Documentation

The operating instructions are a constituent part of the enclosed CD "sipart ps2 POSITIONERS" (order number A5E00214567) and is available on the Internet at:

www.siemens.com/sipartps2

Click on "More Info" and -> "Instructions and Manuals".

On the enclosed CD, you will find an extract of the catalog FI 01 "Field devices for process automation" with the current order data. The entire FI 01 catalog is also available at the above Web address.

0.6 Warranty Information

We should like to point out that the content of this manual is not part of and does not modify a previous or current agreement, undertaking or legal relationship. Siemens is bound solely by the contract of sale, which also contains the complete and exclusive warranty. The contractual warranty conditions are neither extended nor restricted by this document.

0.7 Delivery Notes

The scope of delivery is listed on the dispatch papers accompanying the delivery in accordance with the valid contract of sale.

When you open the packaging please observe the information on the packaging. Check that the delivery is complete and undamaged. If possible, compare the order number on the rating plates with the ordering data.

For the scope of delivery please see Chapter 7, page 153.

0.8 Standards and Regulations

As far as possible, the harmonized European standards were used to specify and manufacture this equipment. If harmonized European standards have not been applied, the standards and regulations of the Federal Republic of Germany apply (see also the Technical Data in Chapter 6, page 147).

If this product is used outside the area of applicability of these standards and regulations, please observe the standards and regulations in force in the country where the product is operated.

www.DataSheet4U.com 1.1 General information about the positioner

The positioner is used to adjust and control pneumatic actuators. The controller operates electropneumatically with compressed air as an energy supply.

Purpose

For example, the positioner can be used to control valves as follows:

- with linear actuator (figure 1-1, page 13) or
- with part-turn actuator VDI/VDE 3845 (figure 1-2, page 13)

Different mounting types are available for linear actuators:

- NAMUR or IEC 534
- integrated mounting to ARCA
- integrated mounting to SAMSON (non-explosion-proof version)

This means the positioner can be installed and operated on all common actuator systems.

Versions

The positioner is available for the following actuators:

- double-acting and
- single-acting

For following applications:

- potentially explosive or
- not potentially explosive applications.

Housing

The electronics with display, position feedback and valve block are integrated in the housing.

The housing is available in three versions:

- Plastic housing for single and double-acting actuators
- Metal housing for single-acting actuators
- Explosion proof housing for single and double-acting actuators

Degree of protection	The device is designed with IP66/NEMA4x degree of protection.
Explosion Protection	<p>The intrinsically safe version can be used in hazardous areas in zone 1 or zone 2.</p> <p>The explosion proof version can be used in hazardous areas in zone 1 or zone 2.</p> <p>The version with the type of protection “n” can be used in hazardous areas of zone 2.</p>
SIL applications	<p>The SIPART PS2 positioners in the variations 6DR501*, 6DR511*, 6DR521* and 6DR531* (i.e. with 0/4 up to 20 mA control signal in the single-acting design) are also suitable for positioning on fittings with pneumatic actuators, which satisfy the special requirements for safety devices up to SIL 2 to IEC 61508/ IEC 61511-1. For this, the SIL safety instructions (see “SIPART PS2 SIL safety manual” A5E00442120) must be followed.</p>
Options	<p>The positioner can be expanded with various options modules (chapter 2.7, page 27). The following modules are available in all:</p> <ul style="list-style-type: none">• I_y-module: Two-wire current output 4 to 20 mA for position feedback• Alarm module: 3 digital outputs and 1 digital input• SIA module: one digital output for fault messages, two digital outputs for limit value alarms
Accessories	<ul style="list-style-type: none">• Manometer block: 2 or 3 manometers for single and double-acting positioners• Connection block (NAMUR) for safety valve block• Mounting kits for linear and part-turn actuator <p>For decentralized installation of the positioner and position sensor:</p> <ul style="list-style-type: none">• External position detection system• Non-Contacting Position Sensor (NCS)
Environmental Protection	<p>Only environmentally friendly materials have been used in the construction of the positioner.</p> <p>The technical manual is printed on chlorine-free bleached paper.</p>

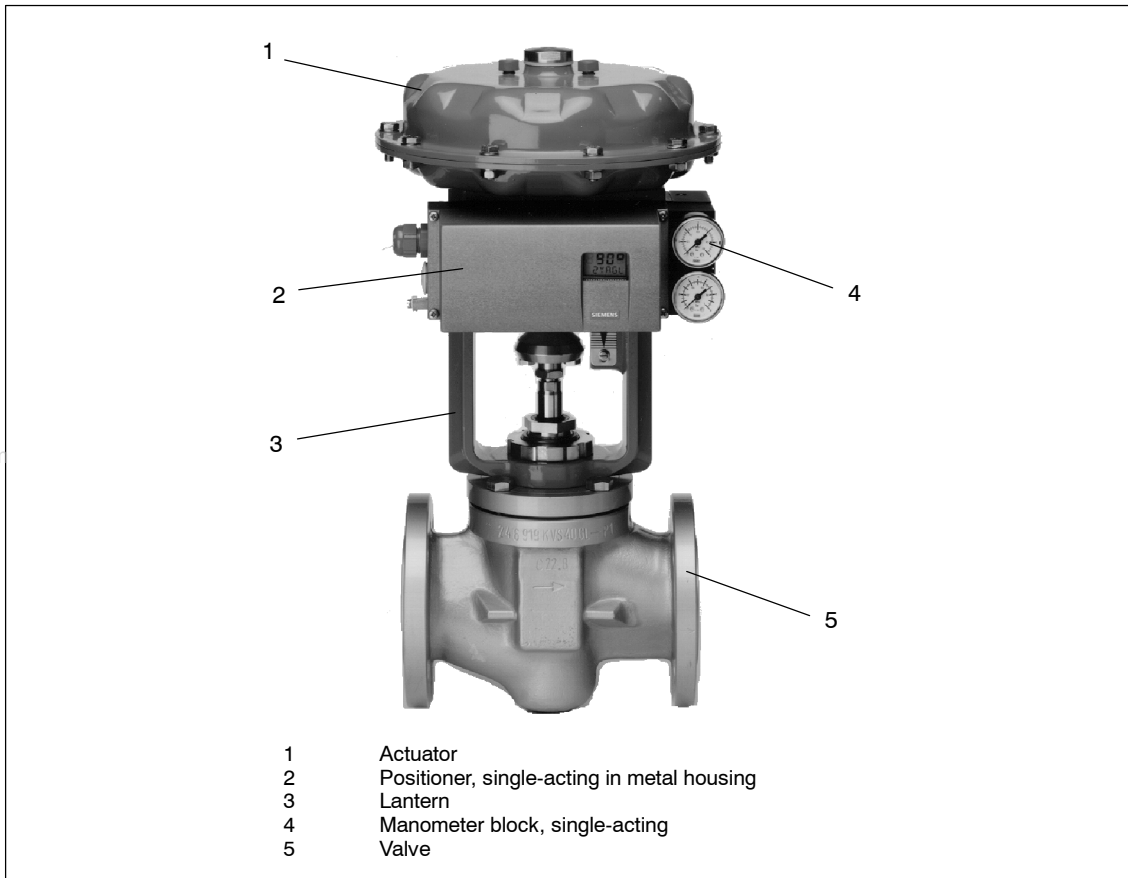
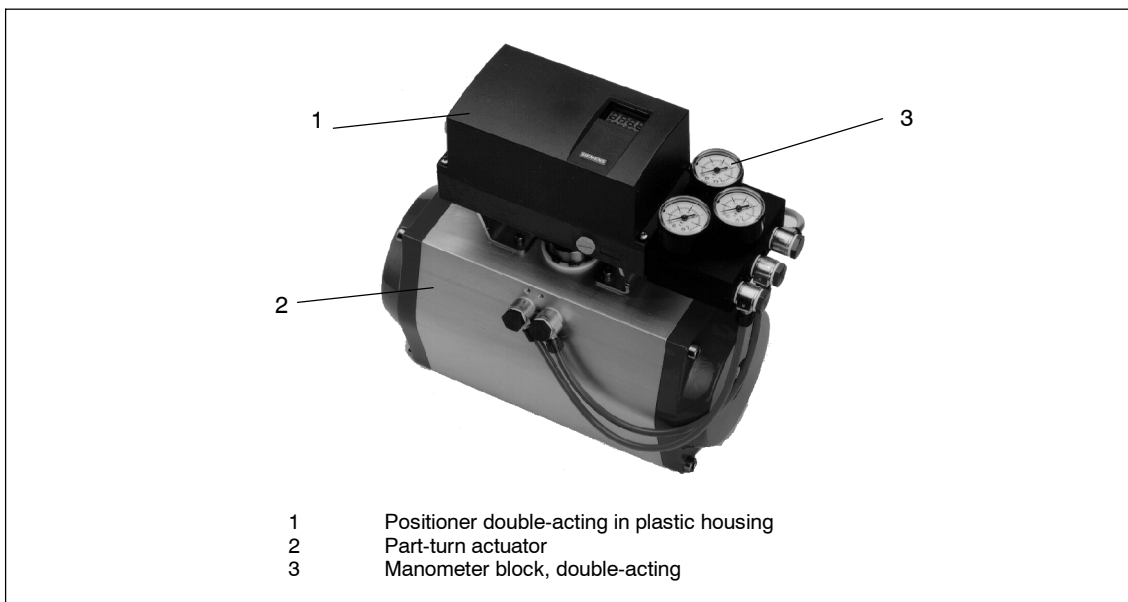
Figure 1-1 Positioner mounted on **linear actuator** (single-acting)Figure 1-2 Positioner mounted on **part-turn actuator** (double-acting)

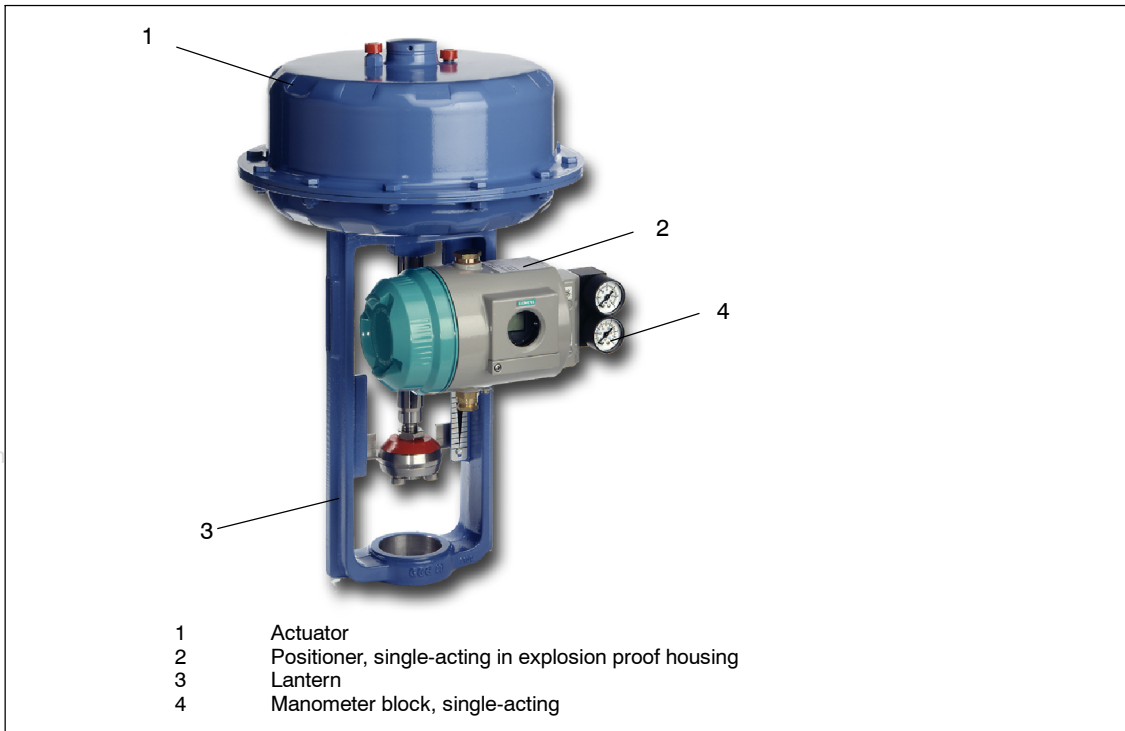

Figure 1-3 Explosion proof version of the positioner mounted on **linear actuator** (single-acting)

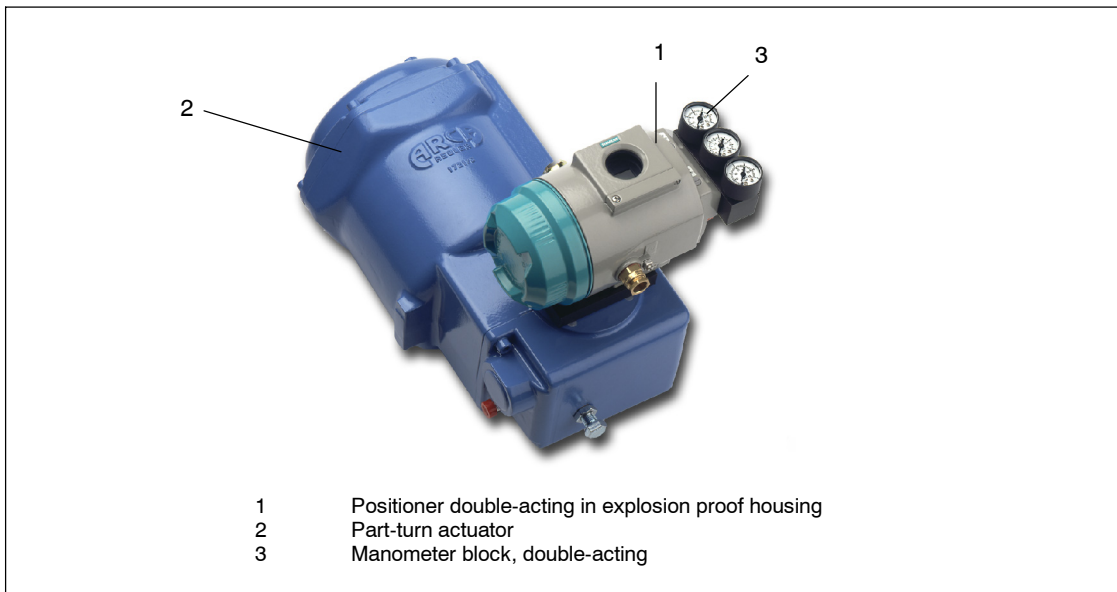

Figure 1-4 Explosion proof version of the positioner mounted on **part-turn actuator** (double-acting)

The following chapter describes the mechanical and electrical design, the instrument components and method of operation of the positioner.

www.DataSheet4U.com

2.1 Overview

Introduction

The electropneumatic positioner forms a control system in connection with an actuator. The current position of the actuator is detected by a servo potentiometer and fed back as actual value x . The setpoint and actual value are output simultaneously on the display.

The setpoint w is formed by a current fed to the positioner which at the same time serves to supply the positioner in two-wire operation. In 3/4-wire operation the supply comes from a 24 V voltage input.

The positioner operates as a predictive five-point switch by the output variable $\pm\Delta y$ of which the integrated actuating valves are controlled with pulse length modulation.

These actuating signals cause fluctuations in pressure in the actuator chamber(s) and thus adjustment of the actuator until the control error is zero.

Operation (manual) and configuration (structuring, initialization and parameterization) is effected by three keys and a display with the housing cover removed.

The standard controller has one digital input (DI1). This can be configured individually and can be used for blocking the operating modes for example.

With the I_y -option module, the current actuator position can be output as a two wire signal $I_y = 4$ to 20 mA.

In addition the actuator can be monitored for two programmable limit values which respond on exceeding or dropping below the stroke or angle of rotation.

The limit value alarms are output by the alarm option module which can monitor and report the function of the positioner and the actuator additionally through a fault message output. The value of the control difference dependent on the travel time is monitored in automatic mode. The fault signal is always set when the control error cannot be leveled after a certain time because for example the valve is blocked or the mains pressure is insufficient. The three digital outputs are implemented as semiconductor outputs and are error self-reporting, i.e. the outputs re-

spond even when the power supply fails or the electronics are defective.

The actuator can also be blocked or driven to its final positions depending on the configuration for example by an external event via a digital input (DI2) on the alarm module.

If you require electrically independent limit value messages from the standard controller, you will have to use the SIA module with the slot initiators instead of the alarm module.

Communication with the controller is possible via the optional HART interface.

To be able to use the positioner with a variety of different part-turn and linear actuators, it has a friction clutch and switchable gearing.

The switchable gearing allows you to adjust the positioner for small and large lifts. You can switch using the yellow switch (8, Fig. 2-11, page 28) between 33° (as delivered) and 90°.

The friction clutch (8, Fig. 2-11, page 28) allows you to set the working range, particularly for linear actuators, after installation. You thus do not have to ensure symmetrical mounting during the installation.

As it is not allowed to open the housing of an explosion-proof version in a potentially explosive atmosphere, the shaft has an externally fitted, additional friction clutch (8, Fig. 2-12, page 31).

NOTICE

for the explosion-proof version:

Only adjust the outer friction clutch (8, Fig. 2-12, page 31). The internal friction clutch (8, Fig. 2-11 page 28) is fixed and, for the explosion-proof version, must **not** be adjusted.

2.2 Name plate design

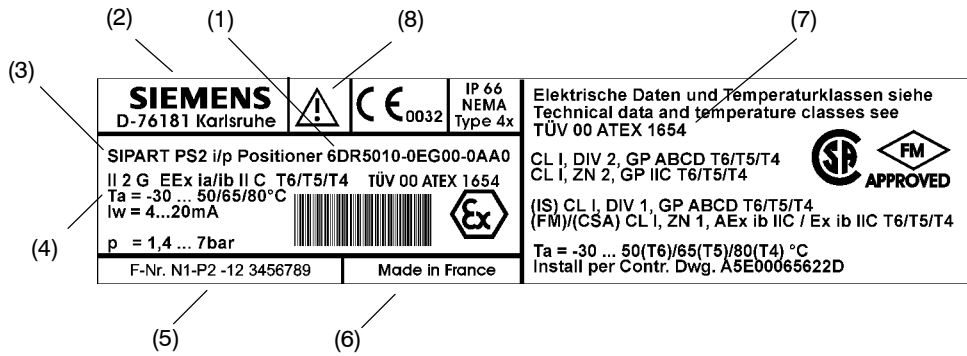

- | | |
|--------------------|--------------------------|
| (1) Order number | (5) Serial number |
| (2) Manufacturer | (6) Place of manufacture |
| (3) Product name | (7) Protection class |
| (4) Technical data | (8) Observe manual |

Figure 2-1 Design name plate, example with protection class EEx ia/ib

2.3 Instrument Components

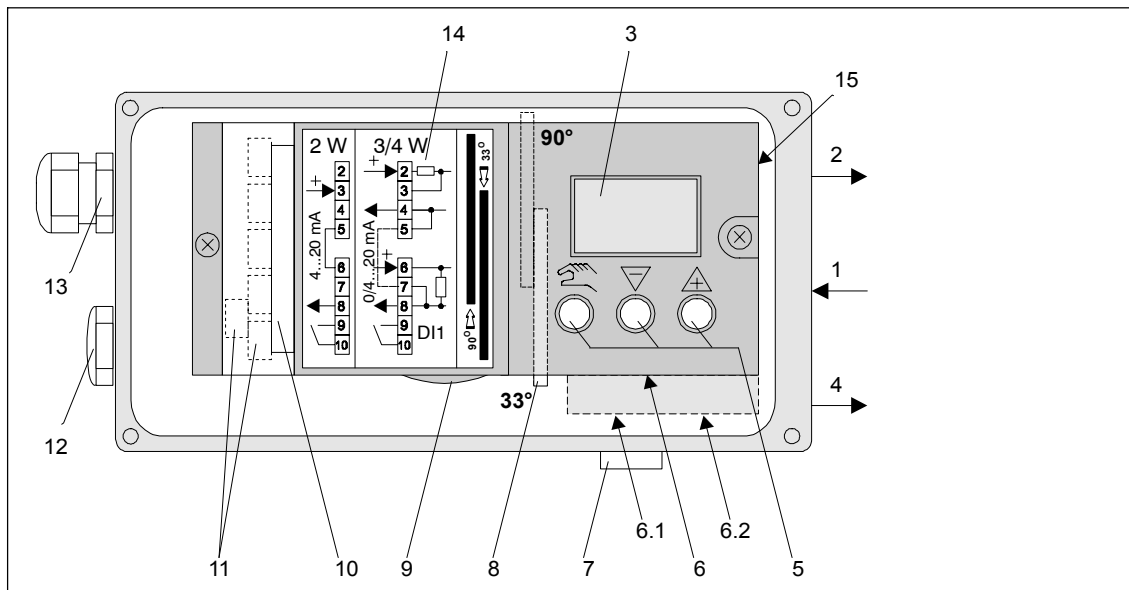

- | | |
|-----------------------------------|---------------------------------------|
| 1 Input: Supply air | 7 Silencer |
| 2 Output: Actuating pressure Y1 | 8 Transmission ratio selector |
| 3 Display | 9 Adjusting wheel for friction clutch |
| 4 Output: Actuating pressure Y2*) | 10 Terminals options modules |
| 5 Operating keys | 12 Dummy plug |
| 6 Restrictor | 13 Screw-type cable gland |
| 6.1 Restrictor Y1 | 14 Terminal plate on cover |
| 6.2 Restrictor Y2*) | 15 Purging air switch |

*) in double-acting actuators

Figure 2-2 View of the positioner in normal version (cover open)

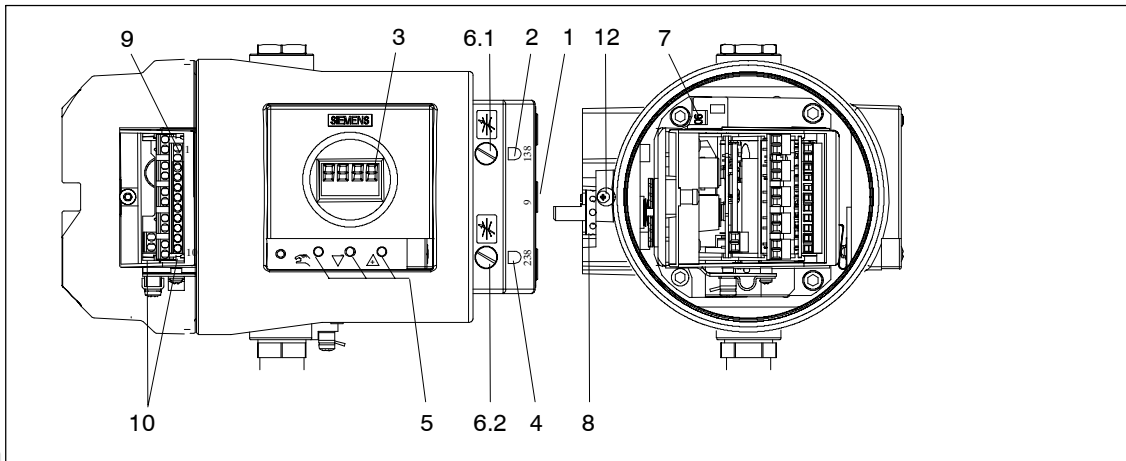

- | | | | |
|-----|----------------------------------|----|---|
| 1 | Input: Supply air | 7 | Transmission ratio selector
(only possible with positioner open) |
| 2 | Output: Actuating pressure Y1 | 8 | Adjusting wheel for friction clutch |
| 3 | Display | 9 | Terminals standard controller |
| 4 | Output: Actuating pressure Y2 *) | 10 | Terminals options modules |
| 5 | Operating keys | 12 | Safety catch |
| 6.1 | Restrictor Y1 | | |
| 6.2 | Restrictor Y2 *) | | |

*) in double-acting actuators

Figure 2-3 View of the explosion proof version of the positioner

2.3.1 Motherboard

The motherboard contains all the electronic elements such as the CPU, memory, A/D converter. It also contains the display and the operating keys.

In addition, the terminal strips for connecting the options modules are also on the motherboard.

2.3.2 Electrical Connections

The terminals of the standard controller, the I_y- and alarm-option module are arranged at the left-hand front edges and offset against each other in staircase form.

A module cover protects the modules from being pulled out and prevents incorrect installation.

2.3.3 Pneumatic Connections

The pneumatic connections are on the right hand side of the positioner (figure 2-4 and figure 2-5).



- 1 Actuating pressure Y1 in single- and double-acting actuators
- 2 Feedback shaft
- 3 Supply air P_z
- 4 Actuating pressure Y2 in double-acting actuators
- 5 Exhaust air output E with silencer on the bottom of the instrument

Figure 2-4 Pneumatic connection in normal version

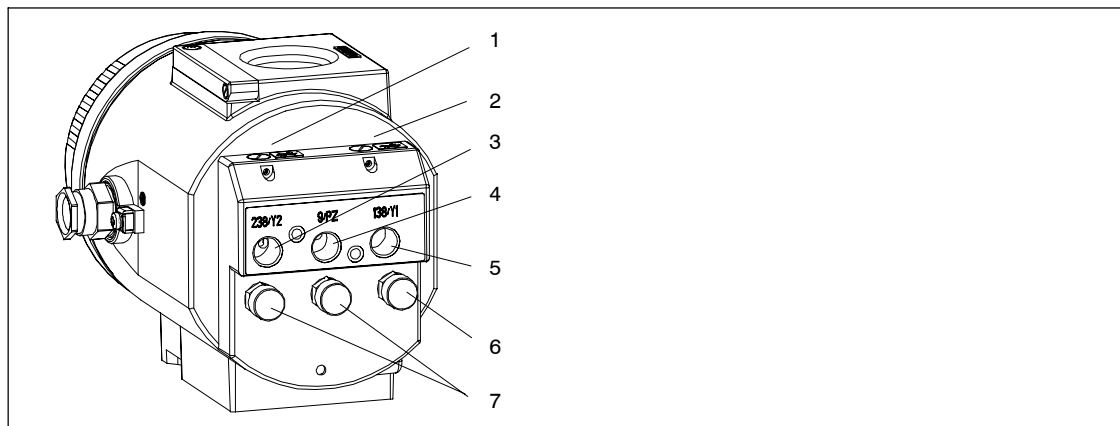

- 1 Restrictor Y2 *)
- 2 Restrictor Y1
- 3 Actuating pressure Y2 *)
- 4 Supply air PZ
- 5 Actuating pressure Y1
- 6 Exhaust air output E
- 7 Housing ventilation (2x)

*) in double-acting actuators

Figure 2-5 Pneumatic connection in explosion proof version

In addition, there are pneumatic connections on the back of the positioner for integrated installation in single-acting linear actuators.

- Actuating pressure Y1
- Exhaust air output E (not in explosion proof version)

In the ex-factory state, these connections are sealed by screws (see figure 3-1, page 41, figure 3-3, page 42 and figure 3-4, page 43).

The exhaust air output E can be provided for supplying dry instrument air to the tapping chamber and spring chamber to prevent corrosion.

Figure 2-6, page 21 shows the pneumatic connection variants for the different actuator types, the positioning action and the safety position after power failure.







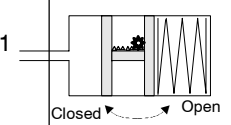

Positioning pressure Connection	Actuator type	Safety position after power failure		
		electrical	pneumatic	
Y1		Closed 	Closed 	<p>In part-turn actuators the direction of rotation counterclockwise looking onto the actuating shaft of the valve is usually defined as "Open".</p>  <p>Closed Open</p>
Y1		Open 	Open 	
Y2		Open 	Last position (before power failure)	
Y1		Closed 		
Y1		Down	Down	 <p>up down</p>
Y1		Up	Up	
Y2		Up	Last position (before power failure)	
Y1		Down		

Figure 2-6 Pneumatic connection positioning

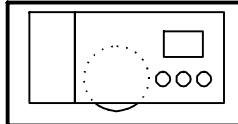
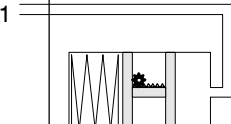
2.3.4 Mounting Kit

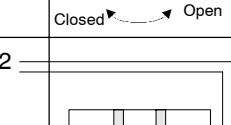
The positioner can be mounted on almost all actuators with the appropriate mounting kit.

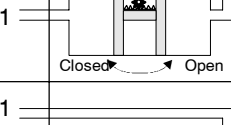
2.3.5 Purge air switching (not in the explosion proof version)

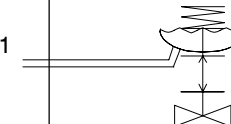
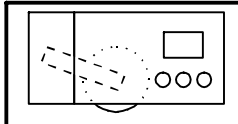
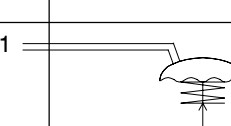
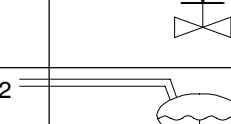
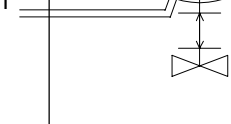
The purge air switch is accessible above the pneumatic terminal strip with the housing open (figure 2-7). In the IN position the inside of the housing is purged with very small amounts of clean, dry instrument air. In the OUT position the purge air is fed directly to the outside air.

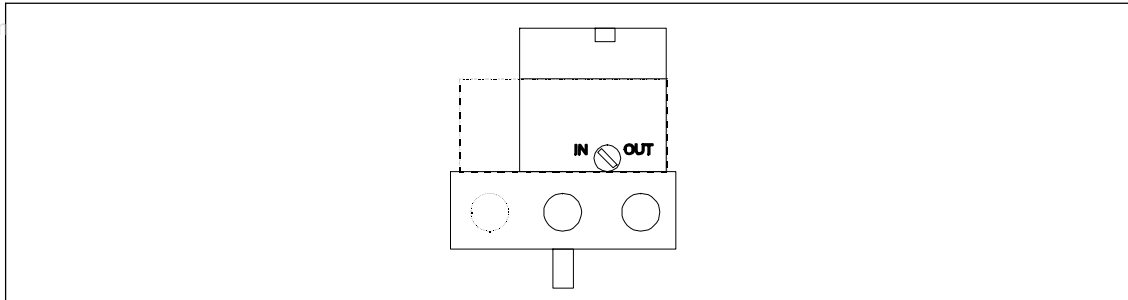

Figure 2-7 Purge air switch on the valve block, view of the positioner onto pneumatic connection side with cover open

2.3.6 Restrictors

In order to achieve travel times of > 1.5 s in small actuators, the air rate can be reduced with the restrictors Y1 and Y2 (figure 2-8, in explosion proof version, see figure 2-5, page 19). By turning to the right the air rate is reduced up to shutting off. To set the restrictors it is advisable to close them and then open them slowly (see initialization RUN3).

In the case of double-acting valves make sure that both chokes are set approximately equal.

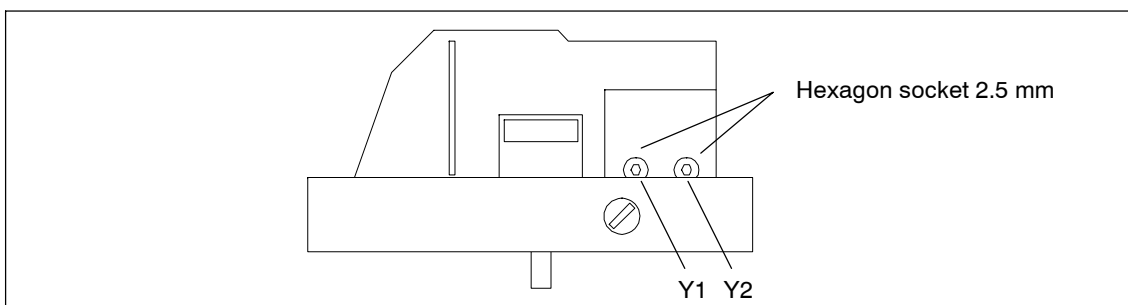

Figure 2-8 Restrictors

2.4 Method of Operation

The electropneumatic positioner SIPART PS2 forms a control circuit with the pneumatic actuator in which the actual value x is the position of the actuator bar in linear actuators or the position of the actuator shaft in part-turn actuators and the command variable w is the actuating current of a controller or a manual control station of 4 to 20 mA.

The stroke or part-turn movement of the actuator is transferred by the appropriate mounting accessories, the feedback shaft and a play-free switchable gearwheel to a high quality conductive plastic potentiometer and to the analog input of the microcontroller. The current position can also be preset for the positioner via an external sensor. The detection of the stroke or rotation angle is performed by a non-contacting position sensor (**Non Contacting Position Sensor**) directly at the actuator.

This may correct the angle error of the stroke tap, compares the potentiometer voltage as actual value x with the setpoint w fed in at the terminals 3 and 7 and calculates the manipulated variable increments $\pm \Delta y$. Depending on the size and direction of the control error ($x-w$) the piezo-controlled supply air or exhaust air valve is opened. The volume of the actuator integrates the positioning increments to actuating pressure y open which moves the actuator bar or actuator shaft approximately proportionally. These positioning increments change the actuating pressure until the control error becomes zero.

The pneumatic actuators are available in single and double-acting versions. Only one pressure chamber is aerated or deaerated in the single-acting version. The resulting pressure operates against a spring. In the double-acting version, two pressure chambers are counteractive. In this case the one volume is deaerated when the other volume is aerated. See the block diagram figure 2-10, page 25.

The control algorithm is an adaptive predictive five-point switch (see figure 2-9, page 24).

The valves are controlled with continuous contact at large control errors (fast step zone). At medium control errors the valve is controlled by pulse length modulated pulses (short step zone).

No actuating pulses are output in the small control error zone (adaptive dead zone). The dead zone adaptation and the continuous adaptation of the minimum pulse lengths in automatic operation cause the best possible control accuracy to be achieved at the lowest switching frequency. The start parameters are determined during the initialization phase and stored in a non-volatile memory. These are basically the real travel with the mechanical limit stops, the travel times, the size of the dead zone etc.

In addition the number of fault messages, changes in direction and the number of strokes are determined and stored every 15 minutes during operation. These parameters can be read out and documented by the communication programs such as PDM and AMS. Conclusions as to the wear on the fitting can be drawn (diagnostic function) especially by comparing the old value with the currently determined values.

Figure 2-10, page 25 shows the block diagrams for single- and double-acting actuators with the linear actuator as an example.



NOTE

The exhaust air valve is always open when there is no current.

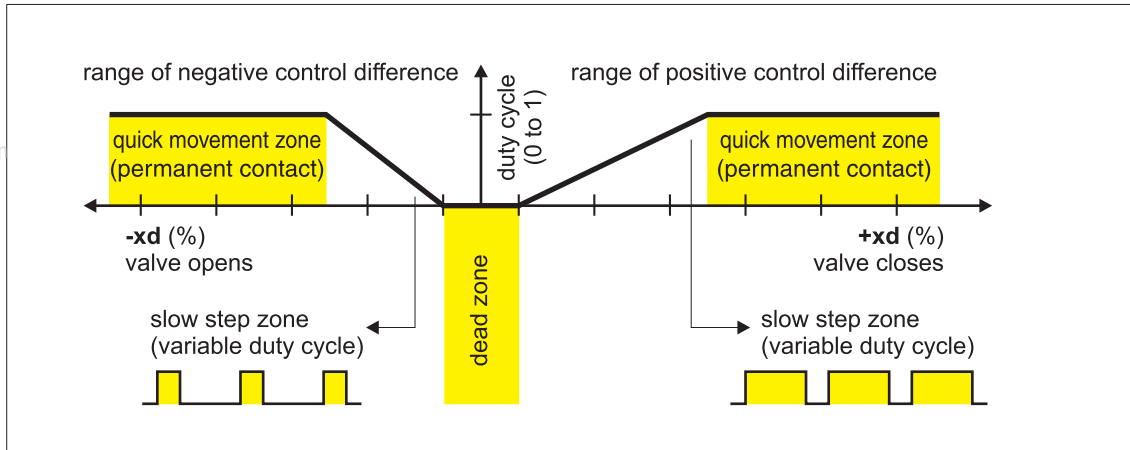
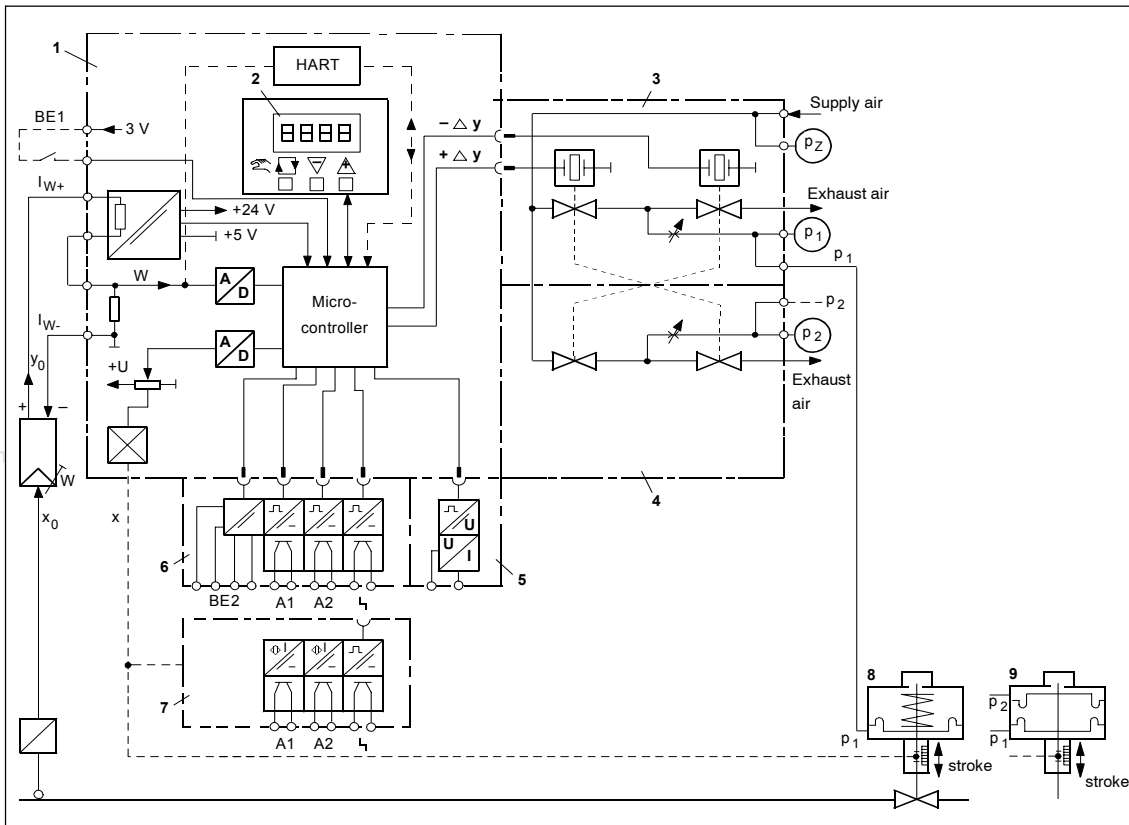

Figure 2-9 Method of operation five-point switch



- 1 Motherboard with microcontroller and input circuit
- 2 Control panel with LC-display and momentary action switch
- 3 Piezo-valve unit, always built-in
- 4 Valve unit with double-acting positioner always built-in
- 5 Iy-module for positioner SIPART PS2
- 6 Alarm module for three alarm outputs and one digital input
- 7 SIA-module (Slot Initiator-Alarm-module)
- 8 Spring-loaded pneumatic actuator (single-acting)
- 9 Spring-loaded pneumatic actuator (double-acting)

Figure 2-10 Block diagram of the electro-pneumatic positioner, functional diagram



NOTE

Alarm module (6) and SIA module (7) can only be used alternatively.

2.5 HART-function

Function

The positioner is also available with built-in HART-functions. The HART protocol allows you to communicate with your instrument with a handheld communicator®, PC or programming unit. This enables you to configure your instrument comfortably, save configurations, call diagnostic data, display online measured values and much more. Communication takes place as frequency modulation over the existing signal lines for the command variable from 4 to 20 mA.

The SPART PS2 is integrated in the following parameterization tools:

- Handheld communicator®
- PDM (Process Device Manager)
- AMS (Asset Management System)
- Cornerstone (without diagnostic values/-functions)



NOTE

Operation on the positioner has priority over the settings via the HART interface.

Communication is aborted by a power failure at the positioner.

2.6 State as supplied

There are no mechanical mounting accessories on the controller in the state as supplied. These must be ordered and installed according to the “operating instructions” depending on the application.

The respective connections for single or double-acting versions are prepared at the factory as ordered.

The pneumatic connections on the rear are sealed.

2.7 Installation of options modules

2.7.1 Installation of options modules in normal and intrinsically safe versions

The following option modules are available for the positioner in the standard and the intrinsically safe version:

- I_y-module
- Alarm module
- SIA-module
- Mechanical limit switch module
- EMC filter module

The installation of the options modules is described below:

Installation

The option modules are secured by a assembly covering ((1), see figure 2-11, page 28) and mechanically fixed.



NOTE

To install the option modules the housing of the positioner needs to be opened. As soon as the positioner is opened, the IP66 degree of protection is not guaranteed.

Open positioner

To open the positioner, the four screws of the housing cover must be loosened with a Phillips screwdriver.

Disconnect or isolate the power supply cables.

Remove the module cover (1). To do this, the two screws (1.1) must be removed with a screwdriver.



NOTE

To prevent premature wearing of the fixture by the self-tapping screws (1.1), the following method of mounting the module cover (1) has proven effective.

1. Turn the screws counterclockwise until you feel them snap into the thread
2. Tighten both screws carefully in clockwise direction

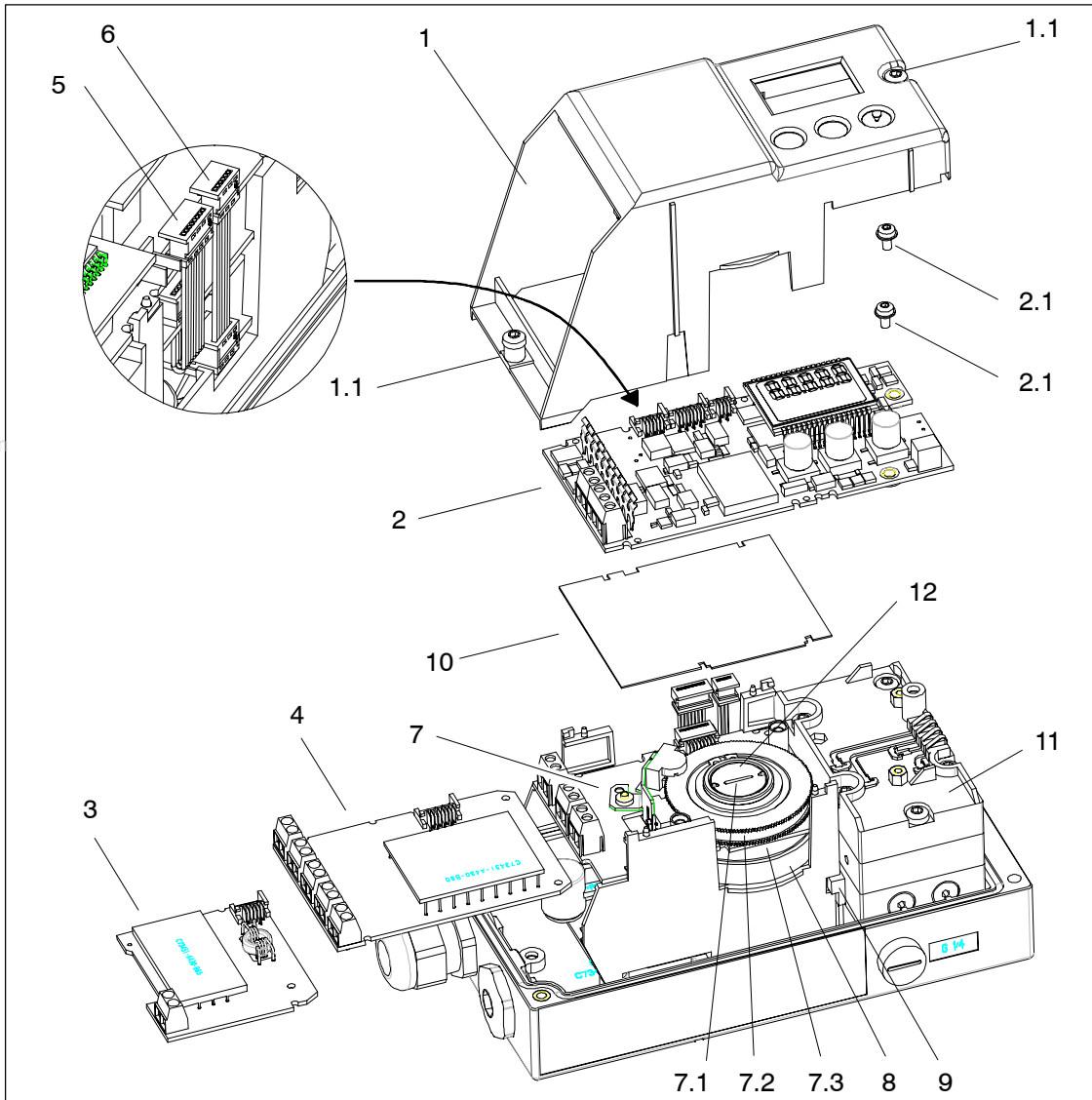

- | | | | |
|-----|--|-----|---|
| 1 | Module cover | 7 | SIA-module and mechanical limit switch module |
| 1.1 | Fixing screws | 7.1 | Special screw |
| 2 | Motherboard | 7.2 | Actuating disc for A1 (terminals 41 and 42) |
| 2.1 | Fixing screws | 7.3 | Actuating disc for A2 (terminals 51 and 52) |
| 3 | I _y -module with ribbon cable (6) | 8 | Adjusting wheel for friction clutch |
| 4 | Alarm module with ribbon cable (5) | 9 | Transmission ratio selector |
| 5 | Ribbon cable for alarm module | 10 | Insulating cover |
| 6 | Ribbon cable for I _y -module | 11 | Pneumatic block |
| | | 12 | Actuating disc bearings |

Figure 2-11 Installation of Options Modules

2.7.2 Installation of options modules in explosion proof version

The following option modules are available for the positioner in the explosion-proof version:

- Iy-module
- Alarm module

Installation

The options modules are protected and mechanically fixed by a module cover ((1), see figure 2-12, page 31).



NOTE

The housing must be opened to install the options modules. The degree of protection IP66/NEMA4x is not guaranteed as long as the positioner is open.



WARNING

In areas in which the atmosphere may be potentially explosive, the explosion-proof positioner may only be supplied with electrical auxiliary power when the housing is closed and when built-in, approved electronics are used.

The feed-through openings for the electronic connections must be sealed with EEX-d certified cable glands or EEx-d certified plugs or an ignition lock must be mounted at a maximum distance of 46 cm (18 inches) when using the "conduit"-system.

Open the positioner

See figure 2-12, page 31. Disconnect or isolate the power supply cables first.

To open the positioner, the safety catch (12) must be opened and the screw-on cover unscrewed.

After loosening the four fixing screws (13.1) the complete rack (13) can be removed. The actuator may have to be turned so that the clutch can be easily disengaged.

Remove the module cover (1). To do this, the two screws (1.1) must be removed with a screwdriver.



NOTE

To prevent premature wearing of the fixture by the self-tapping screw (1.1) next to the display, the following method of mounting the module cover (1) has proven effective.

1. Turn the screws counterclockwise until you feel them snap into the thread.
 2. Tighten both screws carefully in clockwise direction.
-

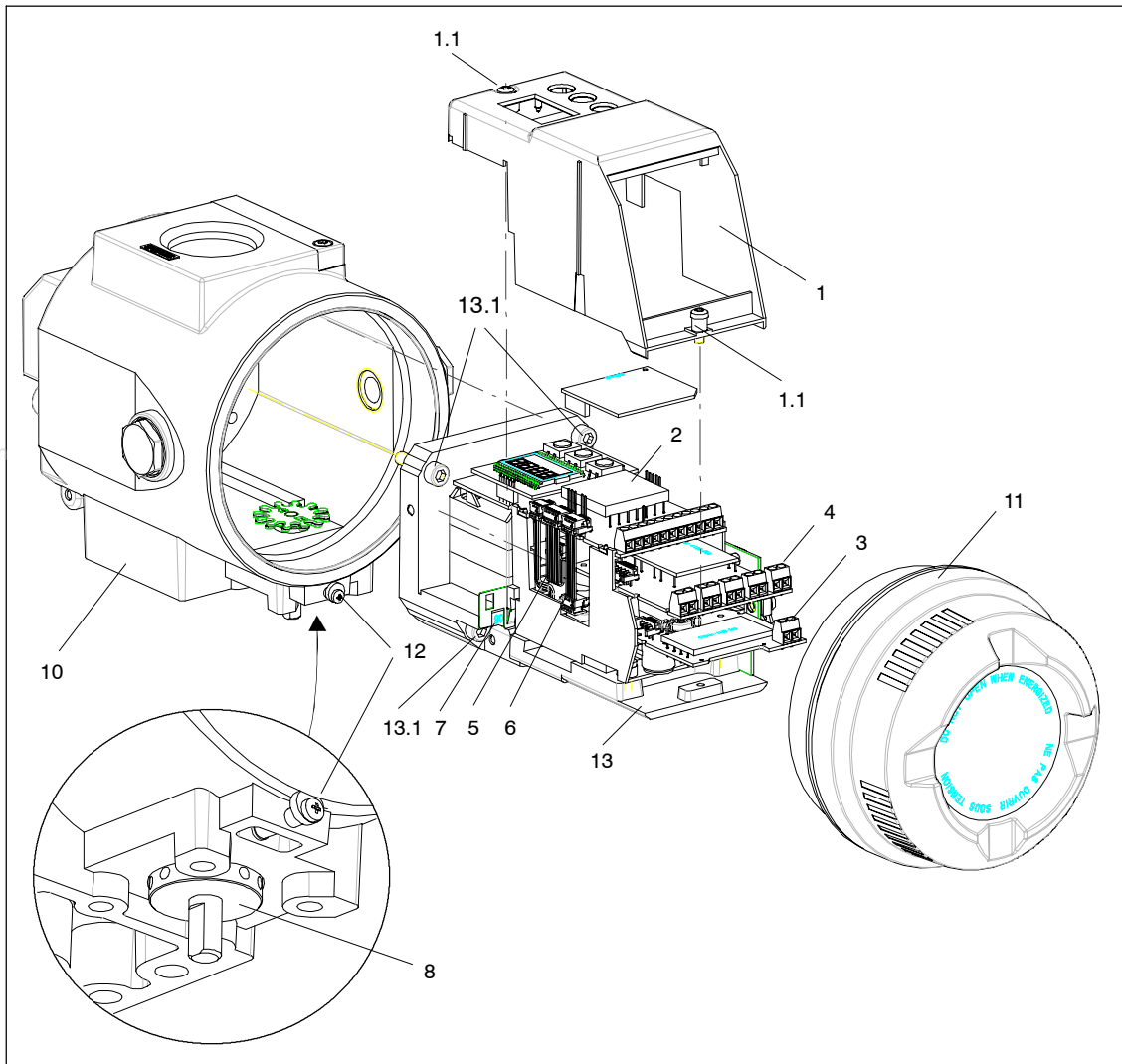

- | | | | |
|-----|---|------|-------------------------------------|
| 1 | Module cover | 7 | Transmission ratio selector |
| 1.1 | Fixing screws | 8 | Adjusting wheel for friction clutch |
| 2 | PA module | 10 | Housing |
| 3 | I _y module with ribbon cable | 11 | Screw-on cover |
| 4 | Alarm module with ribbon cable | 12 | Safety catch |
| 5 | Ribbon cable for alarm module | 13 | Rack |
| 6 | Ribbon cable for I _y module | 13.1 | Fixing screws |

Figure 2-12 Installation of the options modules in the explosion proof version

2.7.3 I_y-module

Function

With the I_y option module, the current actuator position can be output as a two wire signal I_y = 4 to 20 mA – potentially isolated from the standard controller. The dynamic control of the I_y module makes it also error self-reporting.

Installation Insert the I_y module (3) in the lower slot of the rack up to the stop and use the 6-pin flat ribbon cable (6) provided to connect it to the motherboard (see figure 2-11, page 28).

2.7.4 Alarm module

The alarm module contains

- 3 digital outputs and
- 1 digital input

www.DataSheet4U.com **Function**

The digital outputs serve to output fault messages and alarms. The configuration is described in chapter 4.4, page 95, with the parameters 44 to 54.

By an external signal applied at digital input (DI2) the actuator can be blocked or driven to its limit positions for example depending on the configuration. The configuration is described in chapter 4.4, page 95, with the parameters 43.

The alarm module is available in two versions:

- explosion protected for connecting to switching amplifier EN 60947-5-6
- non-explosion protected for connection to voltage sources with a maximum 35 V

The semiconductor outputs of the alarm module report an alarm (signal state Low) by switching off with high resistance. They are conductive in the High state (without alarm). The dynamic control makes them error self-reporting.

The outputs are potentially isolated from the basic circuit and each other.

The digital input is double.

- one potential isolated for voltage level
- one not potential isolated for floating contacts

These two inputs are designed as logic OR links.

Installation Insert the alarm unit (4) below the motherboard in the rack up to the stop and use the 8-pin flat ribbon cable (5) to connect it to the motherboard (see figure 2-11, page 28).

2.7.5 SIA module

The SIA module contains:

- one binary output
- two binary outputs

Function

A collected fault message (see alarm module) is output via the binary output. The floating digital output is implemented as a self error reporting semiconductor output.

The two binary outputs are used to report two mechanically adjustable limit values (L1, L2) via slot initiators. These two outputs are electrically independent of the rest of the electronics.

Installation

(Slot Initiator Alarm module) Proceed as follows for installation (figure 2-11, page 28)::

1. Remove all the electrical connections from the motherboard (2).
2. Loosen the two fixing screws (2.1) of the motherboard.
3. Snap out the motherboard by carefully bending the four holders.
4. Insert the SIA module (7) from above until it reaches the upper circuit board rail of the rack.
5. Push the SIA module into the circuit board rail of the rack approx. 3 mm towards the right.
6. Screw the special screw (7.1) through the SIA module into the axle of the positioner (**Torque: 2 Nm**):

CAUTION

The pin pressed into the actuating disc bearing (12) must be adjusted to just before touching with the special screw. The actuating disc bearing and the special screw must then be turned simultaneously so that the pins slot into the special screw.

7. Place the insulating cover (10) over the SIA module underneath the surface of the motherboard at the container wall on one side. The recesses in the insulating cover must slot into the corresponding lugs on the container wall. Place the insulating cover on the SIA module by carefully bending the container walls.
8. Snap the motherboard into the four holders and screw it tight again with the two fixing screws (2.1).

9. Make all the electrical connections between the motherboard and the options with the ribbon cables provided and between the motherboard and potentiometers with the potentiometer cable.
10. Fix the enclosed module cover instead of the standard version with the two screws (1.1).
11. Select the plates which already exist on the standard version of the module cover from the set of plates enclosed. Stick the selected plates according to the standard version to the mounted module cover. In the case of the version which doesn't feature explosion protection, stick the warning sign onto the side of the ground plate opposite the name plate.
12. Make the electrical connections.

www.DataSheet4U.com

Setting the two limit values:



NOTE

Connect a suitable display instrument such as the Initiator-Tester type 2/Ex made by Peperl+Fuchs to the terminals 41 and 42 or terminals 51 and 52 of the SIA module to be able to see the switching state of the slot initiators.

1. Drive the actuator to the first desired mechanical position.
2. Adjust the top actuating disc (7.2) by hand until the output signal on terminals 41 and 42 changes.
3. Drive the actuator to the second desired mechanical position.
4. Adjust the bottom actuating disc (7.3) by hand until the output signal on terminals 51 and 52 changes.



NOTE

If you turn the actuating disc beyond the switching point up to the next switching point, you can set a high-low or a low-high change.

To avoid the actuating discs being accidentally adjusted during operating, they are relatively sluggish. The following remedy might be of help if you are having trouble with the adjustment: open and close the actuator several times while holding the actuating discs. This temporarily reduces the friction. This allows an easier and finer adjustment.

2.7.6 Mechanical limit switch module

The mechanical limit switch module contains the following:

- A binary output for the output of a group error message)
- Two switches for signaling two limit values that can be set mechanically. These two switches are electrically independent from the rest of the electronic system.

Installation

The installation has to be carried as follows (figure 2-11, page 28):



WARNING

When the mechanical limit switch module is run with AC > 16 V or DC > 35 V (low voltage), the housing must be protected against mechanical actions of > 1 Joule, since otherwise the proper functioning of the IP66 protective system is not guaranteed.



DANGER

When the module is supplied with low voltage, you must observe the basic safety rules before beginning work on the device, such as:

1. Deenergizing the module by disconnecting it via the disconnecting device located directly upstream from the module
2. Securing it against being turned on again
3. Ensuring that the module is disconnected from the voltage supply

CAUTION

The following maximal values only refer to the clamps 41 and 42 as well as the clamps 51 and 52.

Maximal voltage (not Ex)	AC 250 V or DC 24 V
Maximal current (not Ex)	AC/DC 4 A
Maximal voltage (Ex)	DC 30 V
Maximal current (Ex)	DC 100 mA

When you supply one circuit breaker with extra-low voltage (AC < 16 V or DC 35 < V) and the other with low voltage, you ensure that the cable insulation is doubled.

When operating the switch with low voltage, you must position the low voltage circuits so that they are separated from the extra-low voltage circuits.

Follow the instructions below for installation:

1. Remove all electrical connections on the motherboard (2).
2. Loosen carefully both fixing screws (2.1) for the motherboard.
3. Insert the limit switch module (7) from above until it reaches the upper printed circuit board rail of the container.
4. Insert the mechanical limit switch module (7) from above until it reaches the upper circuit board rail of the rack.
5. Push the mechanical limit switch module (7) into the circuit board rail of the rack approx. 3 mm towards the right.
6. Screw the special screw (7.1) through the mechanical limit switch module into the axle of the positioner (**torque: 2 Nm**).

CAUTION

The pin pressed into the actuating disc bearing (12) must be adjusted just before it touches the special screw. In order that the pin slot into the special screw, you must then turn the actuating disc bearing and the special screw simultaneously

7. Place the insulating cover (10) over the mechanical limit switch module underneath the surface of the motherboard onto the container on the wall. The recesses in the insulating cover must slot into the corresponding lugs on the container wall. Place the insulating cover on the mechanical limit switch module by carefully bending the container walls.
8. Snap the motherboard board into the four holders and screw it tight again with the two fixing screws (2.1).
9. Make sure all electrical connections between the motherboard and the options using the ribbon cables provided and between the motherboard and potentiometer using the potentiometer cable.
10. Fix the enclosed module cover (1) instead of the standard version using the two screws (1.1).



NOTE

To prevent premature wearing of the fixture by the self-tapping screws (1.1), the following method of mounting the module cover (1) has proven effective:

- Turn the screws counterclockwise until you feel them snap into the thread.
 - Tighten both screws carefully in a clockwise direction.
-

**NOTE**

Before connecting up the limit contact module, ensure that:

- only qualified personnel connect and set the limit contact module.
- all cables are de-energized.
- the cables are stripped so that the insulation is flush with the terminal when plugging in the wires.
- the ends of stranded wires have sleeves.
- the connection cables are insulated according to the permitted current load.
- the permissible working temperature of the cables exceeds the maximal ambient temperature by $>25\text{ }^{\circ}\text{C}$.
- the Ex-version is only allowed to be operated in intrinsically safe circuits with approved switching amplifiers.

Connection

1. Loosen the screw (1) on the cover (2).
2. Push the cover (2) till it reaches the front stop.
3. Screw each cable tight in the appropriate terminal.
4. Push the cover (2) till it stops at the motherboard.
5. Tighten the screw (1) of the cover (2).
6. Fix the cables of each switch in pairs on the mounting eye using the cable binders provided (3).

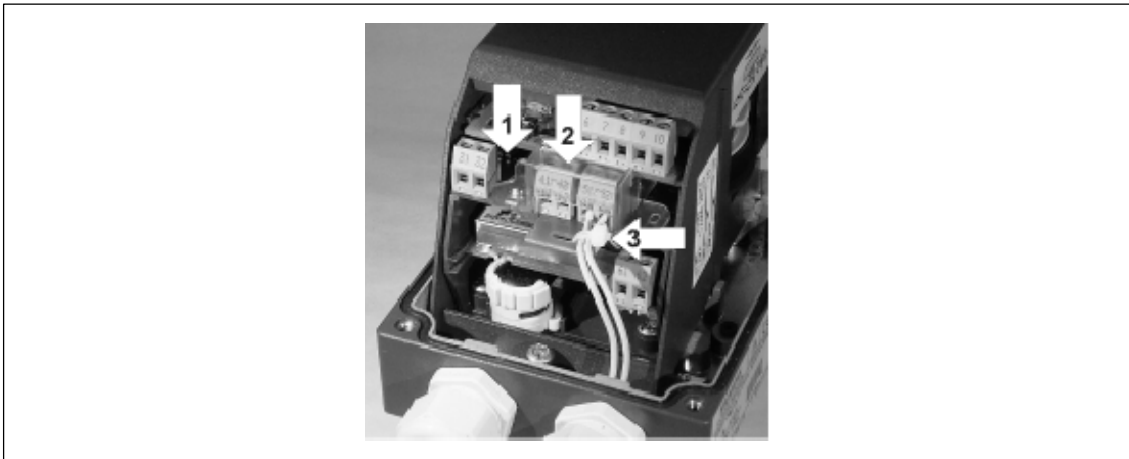

Figure 2-13 Cable connection

Setting the two limit values:

1. Drive the actuator to the first desired mechanical position.
2. Adjust the top actuating disc (7.2) by hand until the output signal on terminals 41 and 42 changes.
3. Drive the actuator to the second desired mechanical position.
4. Adjust the bottom actuating disc (7.3) by hand until the output signal on terminals 51 and 52 changes.



NOTE

To avoid the actuating discs (7.2/7.3) being accidentally adjusted during operation, they are relatively sluggish. The following remedy might be of help if you are having trouble with the adjustment: open and close the actuator several times while holding the actuating discs. This temporarily reduces the friction. This allows an easier and finer adjustment.

2.7.7 EMC filter module

The positioner can also be driven by an external position sensor (potentiometer or NCS) (see page 46 “3.3.2 Instructions for using positioners which are exposed to strong accelerations or vibrations”). An EMC filter module, order number C73451-A430-D23, is required for this.

2.7.8 Accessories

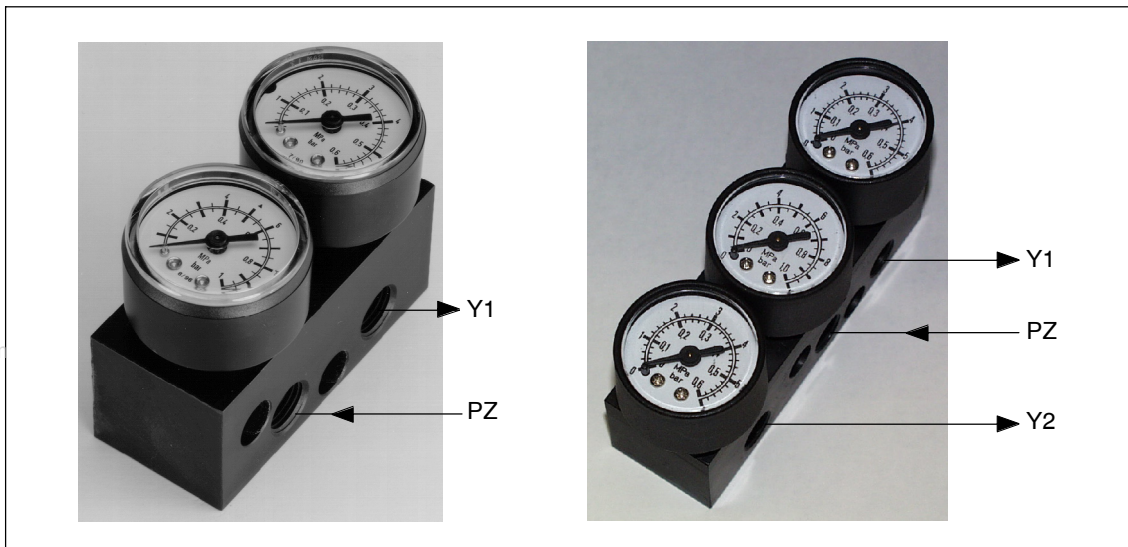

Figure 2-14 Manometer block (left for single-acting, right for double-acting actuators)

Manometer block

The manometer block for single-acting actuator contains two manometers which are screwed to the lateral pneumatic connection of the positioner with O-rings. The values for the input pressure (supply air PZ) and output pressure (actuating pressure Y1) are displayed.

The manometer block for double-acting actuators contains three manometers which are screwed to the lateral pneumatic connection of the positioner with O-rings. The values for the input pressure (supply air PZ) and output pressure (actuating pressure Y1 and Y2) are displayed.

Preparing for Operation

3

This chapter describes all the preparations necessary for operating the positioner.

www.DataSheet4U.com

3.1 Instrument identification (type key)

The order number of the positioner is printed on the rating plate and on the packaging. Compare this with the order number in chapter 7.1, page 154.

Installation of any modules required is described in chapter 2.7, page 27 of this technical manual.

3.2 Dimensional drawings

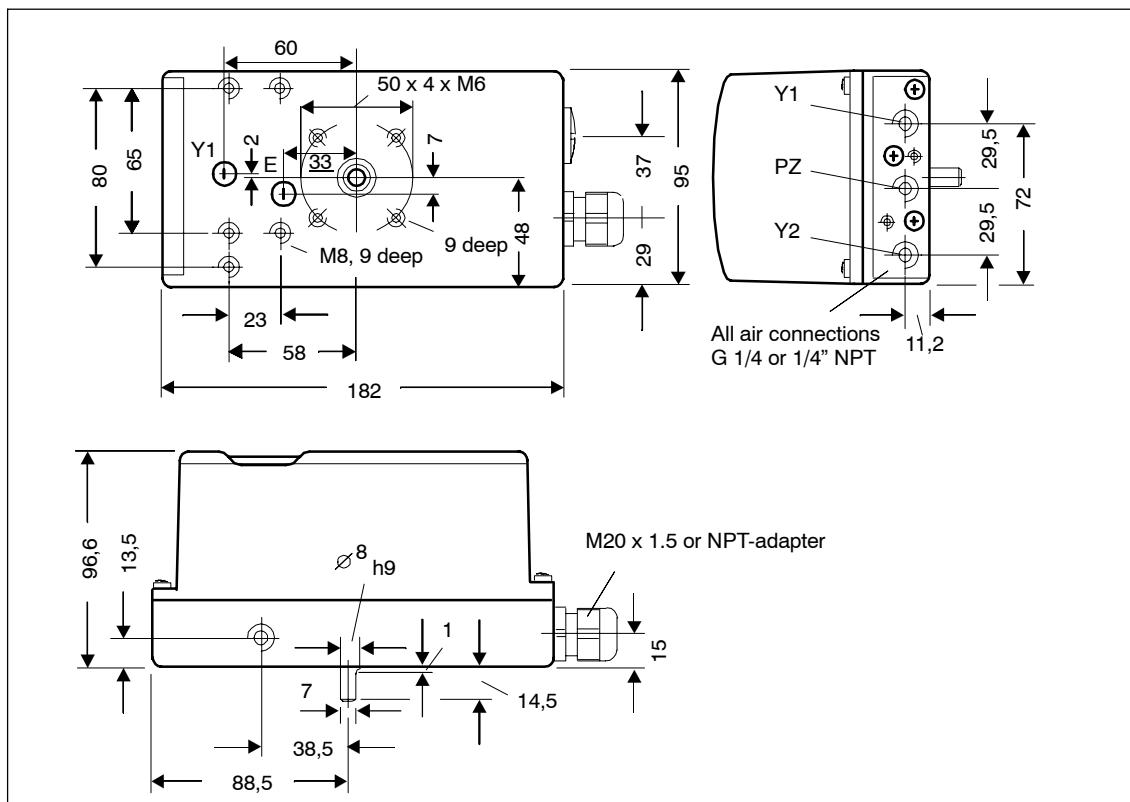

Figure 3-1 Dimensional drawing version plastic housing 6DR5xx0

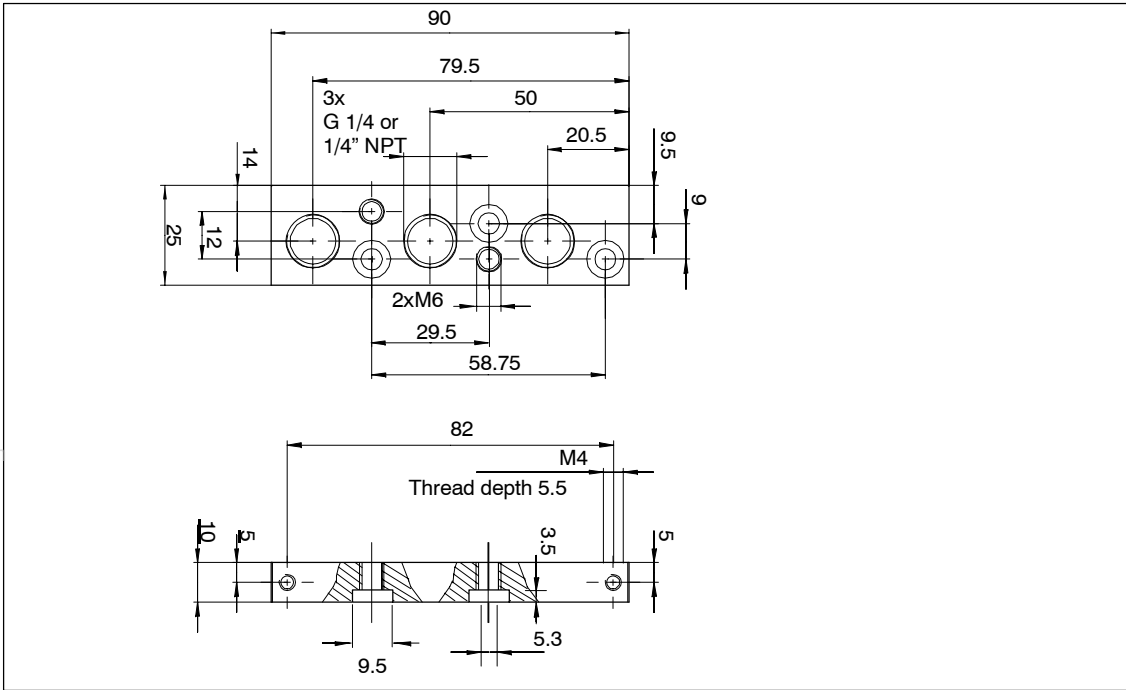

Figure 3-2 Dimensional drawing terminal strip for plastic housing

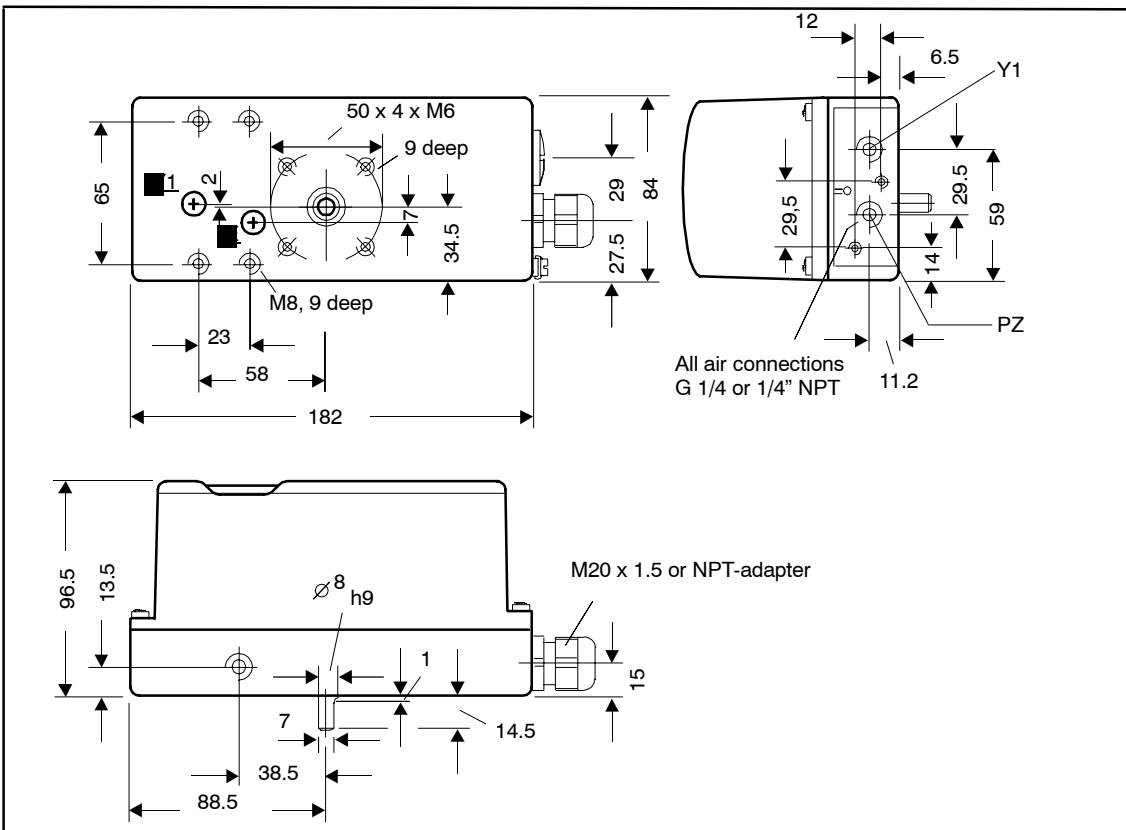

Figure 3-3 Dimensional drawing version metal housing 6DR5xx1

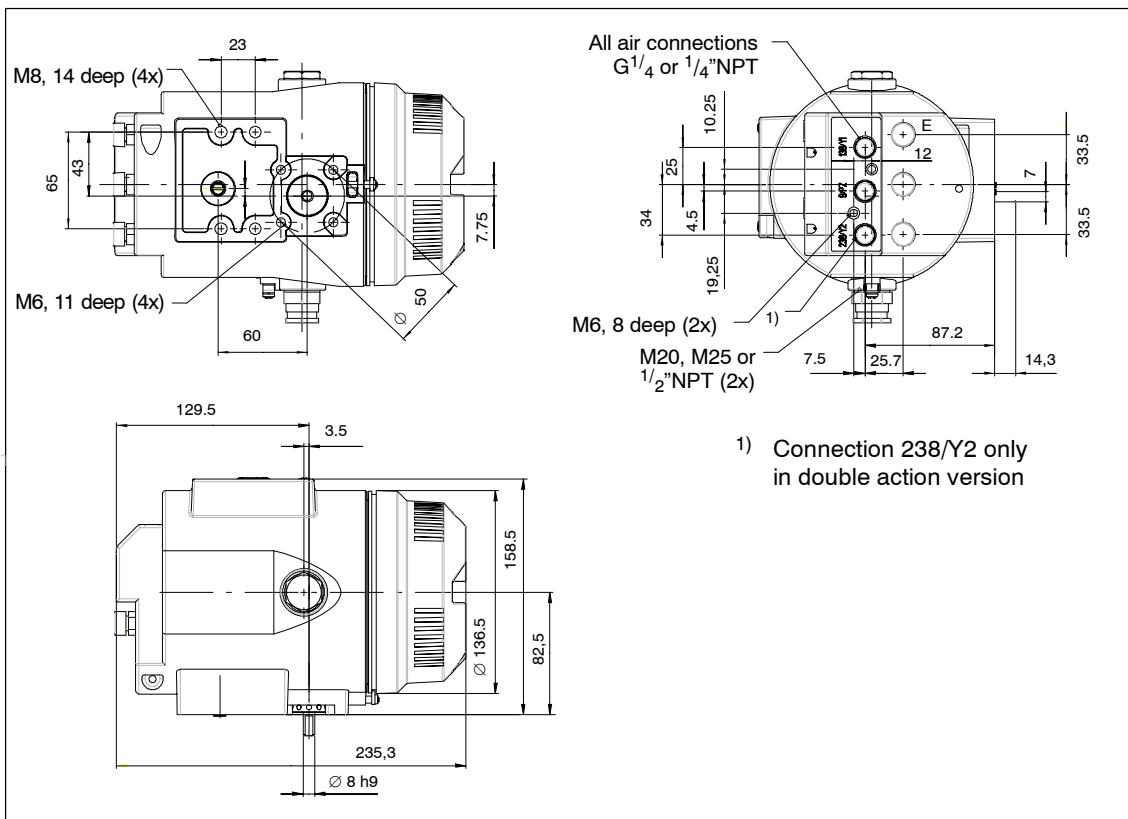

Figure 3-4 Dimensional drawing for positioner with metal housing in explosion proof version 6DR5x5

3.3 Assembly

General



WARNING

To avoid injury or mechanical damage to the positioner/mounting kit, the following order must be observed for assembly:

1. Mechanical fitting of positioner this chapter
2. Connection of electric power supply see chapter 3.4, p. 57
3. Connection of pneumatic power supply see chapter 3.5, p. 71
4. Put into operation see chapter 3.6, p. 72

Please also observe the warning on page 58!



NOTE

The positioner will be equipped at the factory and delivered complete with the necessary options at the customer's request. Options modules may only be retrofitted by our service technicians.

The positioner must be assembled – especially in a moist environment – in such a way as to rule out freezing of the positioner axle at low ambient temperature.

The operating keys must be covered to prevent liquid getting in.



WARNING

In the combination of components it must be ensured that only positioners and options modules are combined which are approved for the respective area of application. This applies especially for safe operation of the positioner in areas in which the atmosphere is potentially explosive (zone 1 and 2). The instrument categories (2 and 3) of the instrument itself and those of its options must be observed.

In addition, you must always make sure that no water gets into an open housing or screw-type gland. This may be the case for example when the positioner cannot be finally assembled and connected immediately.

It generally applies that the positioner may only be operated with dry compressed air. Therefore use the normal water traps. An additional drying unit may even be necessary in extreme cases. This is particularly important when operating the positioner at low ambient temperatures. Please set the purge air switch (on the valve block above the pneumatic terminals) additionally to the "OUT" position.

Use a sufficiently rugged console (e.g. plate thickness > 4 mm with reinforcements) for part-turn actuators and the mounting kit "linear actuator" or integrated connection for linear actuators.

3.3.1 Instructions for using positioners in a wet environment

This information gives you important instructions for the assembly and operation of the positioner in a wet environment (frequent, heavy rain and/or prolonged tropical condensation) in which the IP66 degree of protection is no longer sufficient and especially when there is a danger that water may freeze.

To prevent water getting into the instrument in normal operation (e.g. through the exhaust air openings) or the display being poorly legible, please avoid the unfavorable installation positions illustrated in figure 3-5.

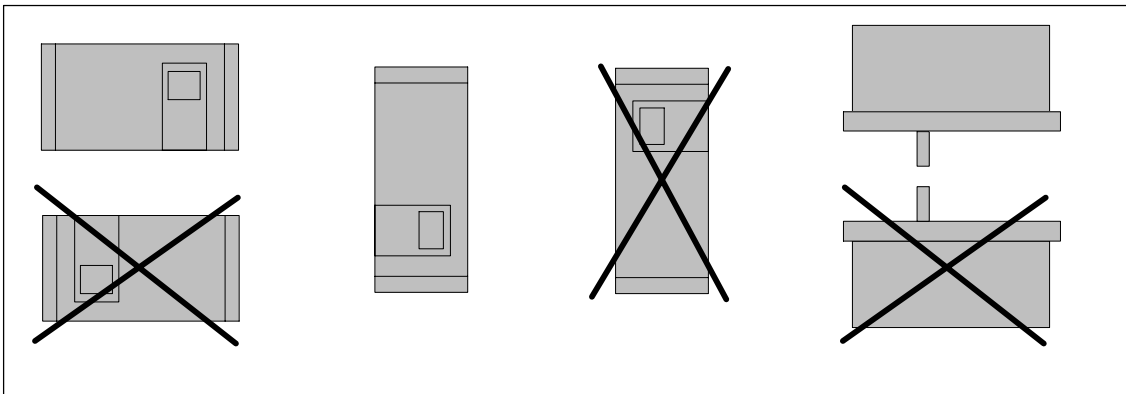

Figure 3-5 Favorable and unfavorable installation positions

www.DataSheet4U.com

If conditions oblige you to operate the positioner in a unfavorable installation position, you can take additional precautionary measures to prevent penetration by water.



NOTE

Never clean the positioner with a high pressure water jet because the IP66 degree of protection is inadequate protection for this.

The necessary additional measures to prevent penetration by water depend on the installation position chosen and you may additionally require:

- screw-type gland with sealing ring (e.g. FESTO: CK -1 / 4-PK-6)
- plastic hose approx. 20 to 30 cm (e.g. FESTO PUN- 8X1,25 SW)
- cable straps (number and length depends on local conditions)

Procedure

- Connect the pipes in such a way that rain water which runs along the pipes can drip off before it reaches the terminal strip of the positioner.
- Check the electrical connections for perfect firm contact.
- Check the seal in the housing cover for damage and contamination. Clean and replace if necessary.
- Mount the positioner if possible so that the sinter bronze silencer faces downwards on the underside of the housing (vertical installation position). If this is not possible, the silencer should be replaced by a suitable screw-type gland with a plastic hose.

Assembly of the screw-type gland with plastic hose

- Unscrew the sinter bronze silencer from the exhaust air opening on the underside of the housing.
- Screw the screw-type gland mentioned above into the exhaust air opening.
- Mount the above mentioned plastic hose on the screw-type gland and check the good fit.
- Fix the plastic hose with a cable strap to the fitting so that the opening faces downwards.
- Make sure that the hose has no kinks and the exhaust air can flow out unhindered.

www.DataSheet4U.com

3.3.2 Instructions for using positioners which are exposed to strong accelerations or vibrations

NOTICE

for explosion-proof versions:

Only adjust the outer friction clutch (8, Fig. 2-12, page 31). The internal friction clutch (8, Fig. 2-11, page 28) is fixed and, for the explosion-proof version, must **not** be adjusted.

The electro-pneumatic positioner SIPART PS2 has a friction clutch and switchable gearing and can thus be used universally for part-turn and linear actuators. This means that, for part-turn actuators you don't have to worry about the zero point and for linear actuators, you don't have to worry about symmetrical mounting, as you can adjust the working range after installation, with the help of the friction clutch.

The switchable gearing allows you to also adjust the positioner for small or large lifts.

Occasionally it can happen, that in the rough environment of process systems (e.g. due to incorrectly fitted valves or if "steam pulses" occur) that the shaft to monitor the position of the SIPART PS2 positioner is exposed to extreme acceleration, which far exceeds its specified load limits, and which could result in an unwanted shift in the friction clutch or in the gears in the position monitoring jumping briefly out.

For cases like this, as standard, the SIPART PS2 positioner is fitted with a locking device for the friction clutch and you can also lock the setting of the transmission ratio selector. This means that an unwanted change to the position monitoring due to the above mentioned effects can be reliably prevented.

Both of these locking options are labeled via additional tags inside the device (see Figure 3-6, page 47). Note that these locks are only required if extreme acceleration or strong vibration might be present within your process.

Procedure

After you have installed the positioner and put it fully into operation, you can set the torque for the friction clutch as follows:

- On the module cover, insert an ordinary 4 mm wide screwdriver into a slot on the yellow wheel.
- Now use the screwdriver to move the yellow wheel to the left, until you can feel that it clicks in. This increases the torque of the friction clutch.
- You can recognize a locked friction clutch by an approx. 1 mm wide gap between the yellow and black wheels.
- If you have to set the zero pint e.g. after exchanging the actuator, first reduce the torque by turning the yellow wheel to the right until you hit the stop. After setting the zero point, you can refix the friction clutch as described above.

Starting from the neutral setting (as delivered), you can lock the transmission ratio selector as follows:

- Adjust the yellow wheel underneath the terminals with an ordinary 4 mm wide screwdriver to correspond to the setting that you would like (33° or 90°), turning to the left or right, until you can feel that it clicks in.
- Please note that you can only adjust the transmission ratio selector after releasing the fixing. For this reason you first have to put the yellow ring into the neutral position, if you have to adjust the transmission ratio selector e.g. after exchanging the actuator).

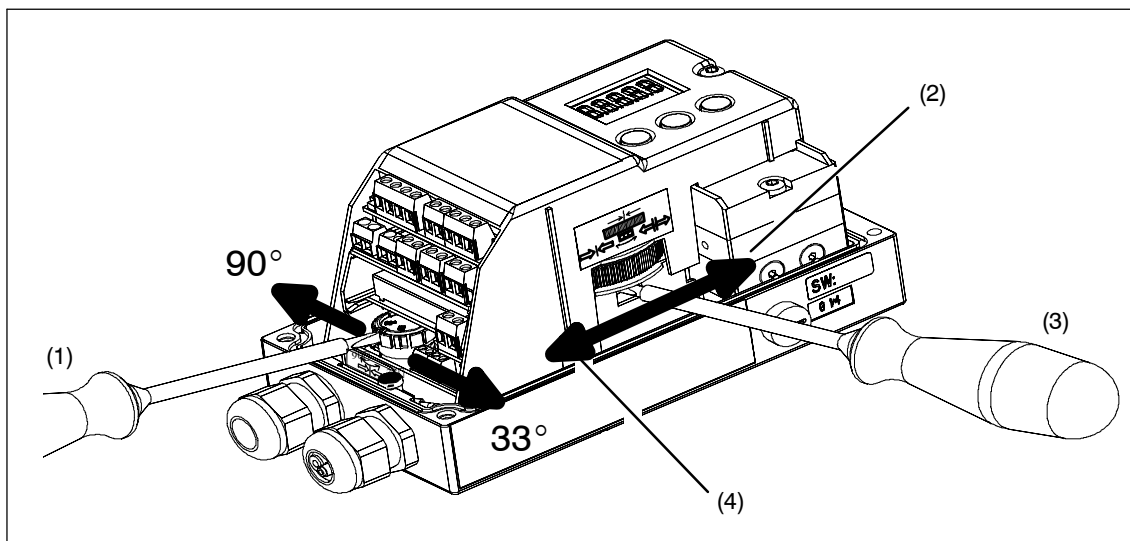

- (1) Transmission ratio selector interlock
- (2) Open
- (3) Friction clutch
- (4) Close

Figure 3-6 Locking and fixing mechanisms

External position displacement sensor

Applications in which the measures described above are inadequate are also conceivable. This applies for instance with continuous and heavy vibration, increased or too low ambient temperatures and in the case of nuclear radiation.

The separate attachment of position displacement sensor and controller unit can help here. A universal component is available which is suitable both for linear and part-turn actuators.

You require the following:

- The external position detection system (order no. C73451-A430-D78). This consists of a SIPART-PS2-housing with integrated friction clutch, built-in potentiometer and various dummy plugs and seals.
- or a Non-Contacting Position Sensor (e.g. 6DR4004-6N).
- The controller unit, any positioner version.
- The EMC filter module, this is a set together with cable clips and M-20 screw-type cable gland and has the order number C73451-A430-D23. The EMC filter module must be installed in the positioner. The installation instructions enclosed with the EMC filter module explain how to assemble the components.
- A 3-wire cable for connecting the components.

This EMC filter module should always be used for the controller unit when any actuator-mounted potentiometer (resistance 10 k Ω) is to be used instead of the position detection system C73451-A430-D78.



WARNING

The explosion-proof version may not be run together with the external position detection system.

3.3.3 Mounting kit “linear actuator” 6DR4004-8V and 6DR4004-8L

The scope of delivery of the mounting kit “linear actuator IEC 534 (3 mm to 35 mm)” are contained (ser. no. see figure 3-7, page 51):

Ser. no.	pieces	Designation	Note
1	1	NAMUR mounting kit bracket IEC 534	Standardized connection for mounting console with ledge, column or plane surface
2	1	Pick-up bracket	Guides the roller with carrier pin and turns lever arm
3	2	Clamping assembly	Mounting of pick-up bracket on actuator spindle
4	1	Carrier pin	Assembly with roll (5) on lever (6)
5	1	Roll	Assembly with driver pin (4) on lever (6)
6	1	Lever NAMUR	For stroke range 3 mm to 35 mm For stroke ranges > 35 mm to 130 mm (special delivery), lever 6DR4004-8L is required additionally
7	2	U bolt	Only for actuators with columns
8	4	Hexagon head screw	M8 x 20 DIN 933-A2
9	2	Hexagon head screw	M8 x 16 DIN 933-A2
10	6	Lock washer	A8 – DIN 127-A2
11	6	Flat washer	B 8,4 – DIN 125-A2
12	2	Flat washer	B 6,4 – DIN 125-A2
13	1	Spring	VD-115E 0.70 x 11.3 x 32.7 x 3.5
14	1	Spring washer	A6 – DIN 137A-A2
15	1	Lock washer	3.2 – DIN 6799-A2
16	3	Spring washer	A6 – DIN 127-A2
17	3	Socket cap screw	M6 x 25 DIN 7984-A2
18	1	Hexagon nut	M6 – DIN 934-A4
19	1	Square nut	M6 – DIN 557-A4
21	4	Hexagon nut	M8 – DIN 934-A4

Table 3-1 Scope of delivery of the mounting kit “linear actuator”

3.3.4 Assembly procedure (see figure 3-7, page 51)

1. Mount clamping assembly (3) with hexagon socket cap screws (17) and lock washer (16) on the actuator spindle.
2. Insert the pick-up bracket (2) into the recesses of the clamping assembly. Set the necessary length and tighten the screws so that the pick-up bracket can still be shifted.
3. Insert the pin (4) in the lever (6) and assemble with nut (18), spring washer (14) and washer (12).
4. The value of the stroke range specified on the actuator or if this does not exist as a scaling value, the next greatest scaling value is set. The center of the pin must be in line with the scaling value. The same value can be set later under parameter 3.YWAY in commissioning to display the way in mm after initialization.
5. Assemble the hexagon socket cap screw (17), spring washer (16), washer (12) and square nut (19) on the lever.
6. Push the premounted lever onto the positioner axis up to the stop and fix with the hexagon socket cap screw (17).
7. Fit the mounting bracket (1) with two hexagon head screws (9), lock washer (10) and flat washer (11) on the rear of the positioner.
8. Selection of the row of holes depends on the width of the actuator yoke. The pin (4) should engage in the pick-up bracket (2) as close as possible to the spindle but may not touch the clamping assembly.
9. Hold the positioner with the mounting bracket on the actuator so that the pin (4) is guided within the pick-up bracket (2).
10. Tighten the pick-up bracket.
11. Position the mounting parts according to the type of actuator.
 - Actuator with ledge: Hexagon head screw (8), flat washer (11) and lock washer (10).
 - Actuator with plane surface: Four hexagon head screws (8), flat washer (11) and lock washer (10).
 - Actuator with columns: Two U bolts (7), four hexagon nuts (21) with flat washer (11) and lock washer (10).
12. Secure positioner onto the yoke using the previously positioned mounting parts.



NOTE

Set the height of the positioner so that the horizontal lever position is reached as close to the stroke center as possible. You can use the lever scale as orientation. It must be guaranteed that the horizontal lever position is passed through within the stroke range.

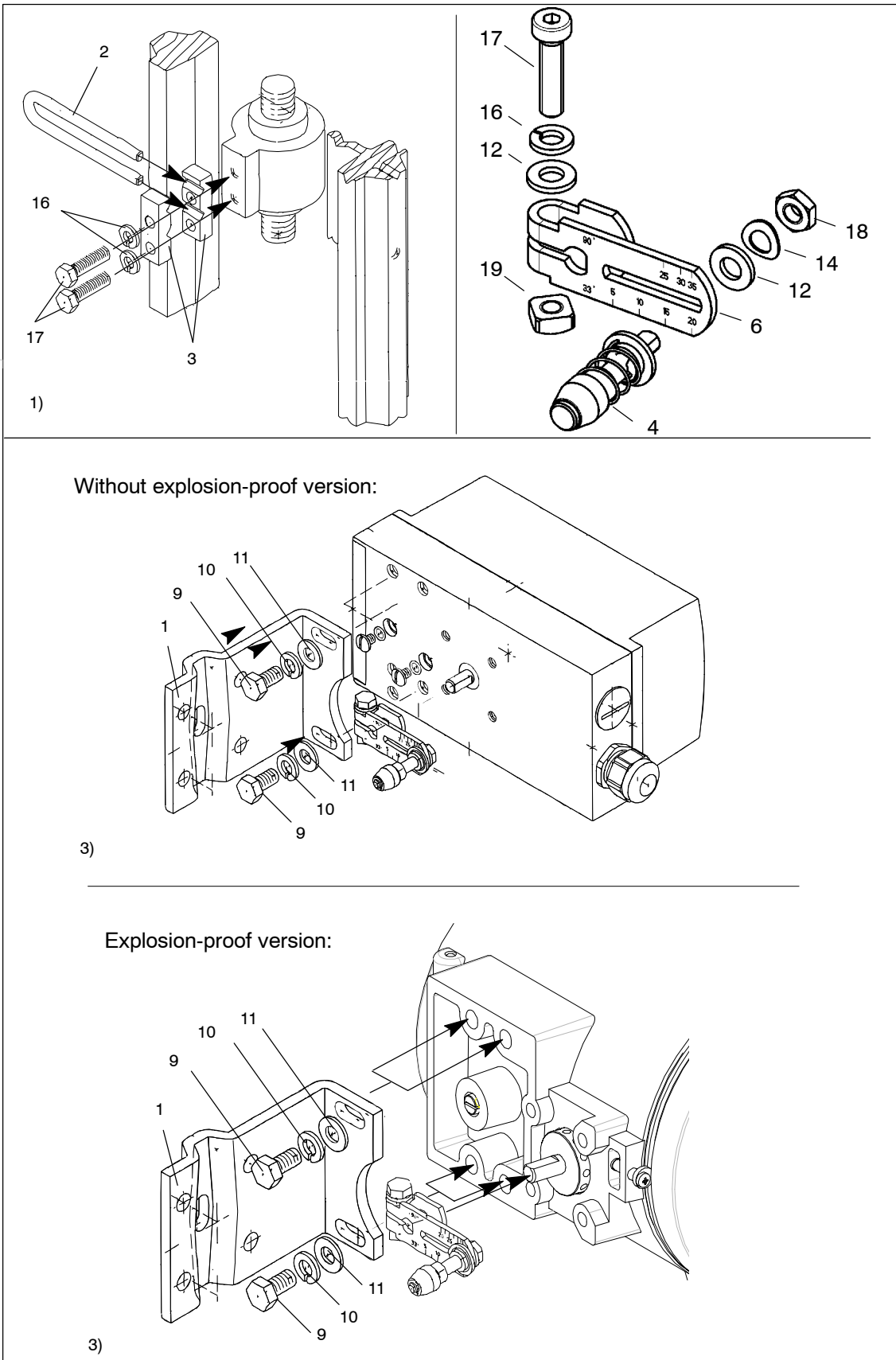

Figure 3-7 Assembly procedure (linear actuator)

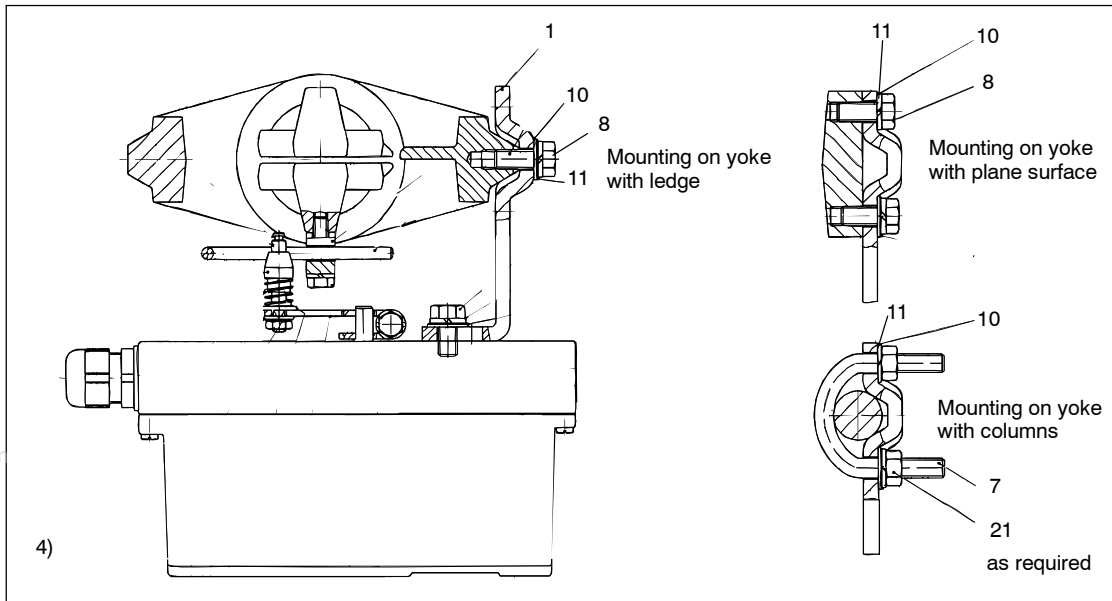

Figure 3-7 Assembly procedure (linear actuator) *continued*

3.3.5 Mounting kit “part-turn actuator” 6DR4004-8D

The *scope of delivery of the mounting kit “part-turn actuator”* contains (ser. no. see figures 3-8 and 3-9):

Ser. no.	Pieces	Designation	Note
2	1	Coupling wheel	Mounting on position feedback shaft of the SIPART PS2
3	1	Carrier	Mounting on end of actuator shaft
4	1	Multiple plate	Indication of actuator position, comprising 4.1 and 4.2
4.1	8	Scales	Different divisions
4.2	1	Pointer mark	Reference point for scale
14	4	Hexagon head screw	DIN 933 – M6 x 12
15	4	Lock washer	S6
16	1	Fillister head screw	DIN 84 – M6 x 12
17	1	Washer	DIN 125 – 6.4
18	1	Hexagon socket head screw	Premounted with coupling wheel
19	1	Allen key	For item 18

Table 3-2 Scope of delivery of the mounting kit “part-turn actuator”

3.3.6 Assembly procedure (see figure 3-8 and figure 3-9)

1. Attach VDI/VDE 3845 mounting console ((9), actuator-specific, scope of delivery actuator manufacturer) onto rear of positioner and secure using hexagon head screws (14) and lock washers (15).
2. Adhere pointer (4.2) onto mounting console in the center of the centering hole.
3. Push the coupling wheel (2) onto positioner axis, pull back by about 1 mm and tighten the hexagon socket head screw (18) with the Allen key provided.
4. Place the carrier (3) onto the end of the actuator and secure using Fillister head screw (16) and washer (17).
5. Carefully place positioner with mounting console onto the actuator such that the pin of the coupling wheel engages in the actuator.
6. Align the positioner/mounting console assembly in the center of the actuator and screw tight.
(Screws not included in delivery; they are part of the actuator mounting console!)
7. Following startup as described in Chapter 3.6, page 72: Drive the actuator to the end position and adhere scale (4.1) on the coupling wheel (2) according to direction of rotation and part-turn actuator.
The scale is self-adhesive!

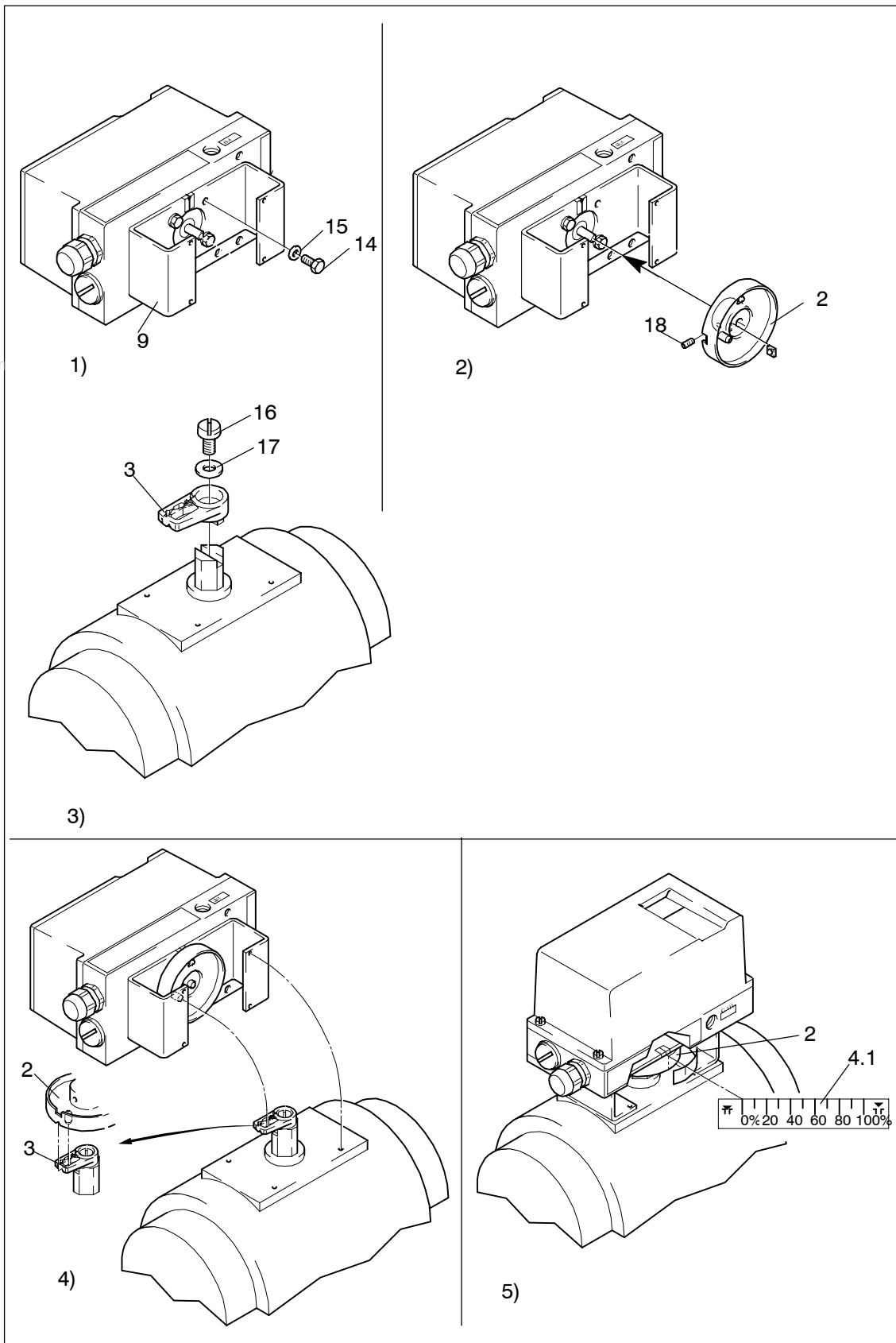

Figure 3-8 Assembly procedure (part-turn actuator)

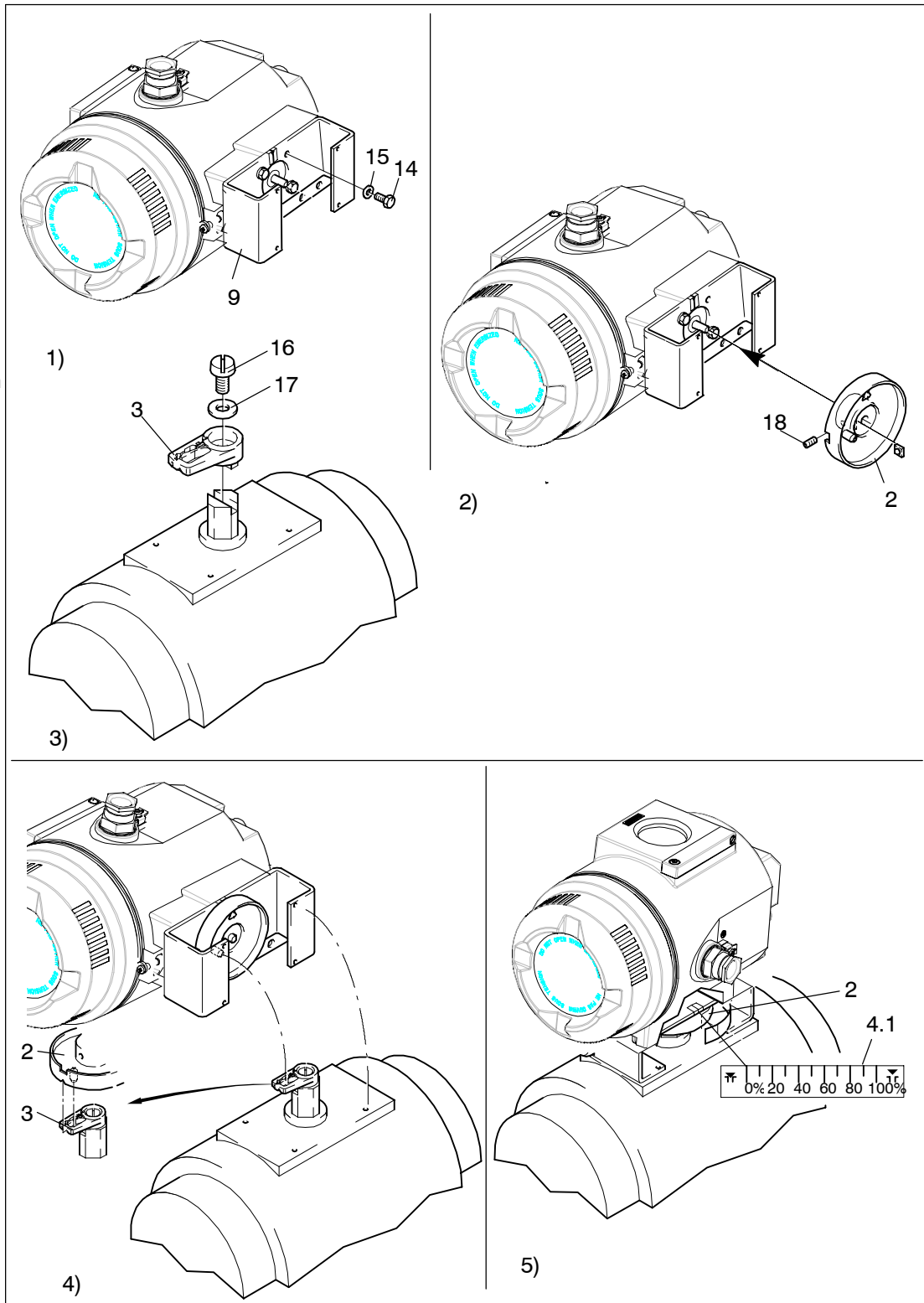
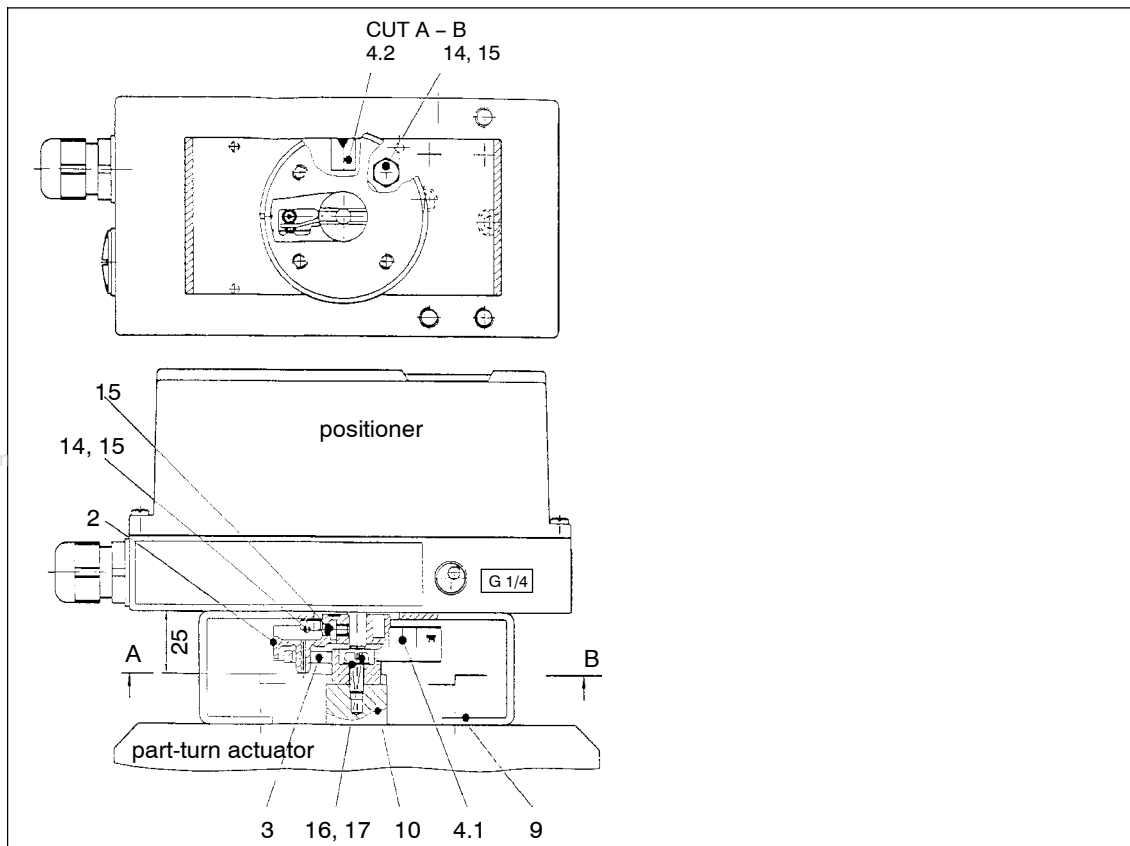

Figure 3-9 Assembly procedure for **explosion proof version** (part-turn actuator)



- | | | | |
|-----|-------------------------------|----|------------------------------|
| 2 | Coupling wheel | 10 | Feedback shaft |
| 3 | Carrier | 14 | Hexagon head screw M6 x 12 |
| 4 | Multiple plate | 15 | Lock washer S6 |
| 4.1 | Scale | 16 | Fillister head screw M6 x 12 |
| 4.2 | Pointer mark | 17 | Washer |
| 9 | VDI/VDE 3845-mounting bracket | 18 | Hexagon socket head screw |

Figure 3-10 Mounted positioner for part-turn actuator

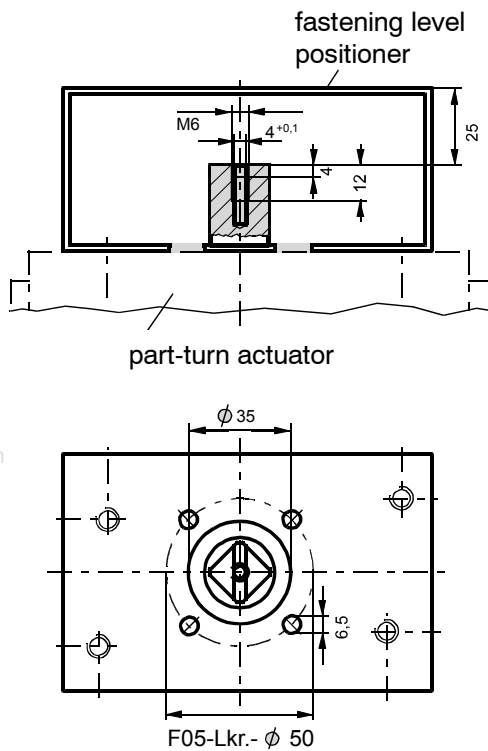

Figure 3-11 Attachment of part-turn actuator, mounting console (scope of delivery actuator manufacturer), dimensions

3.4 Electrical Connection



NOTE

Any necessary options modules must be installed before electrical connection (see chapter 2.7, page 27).

N.B.: The transmission ratio selector can only be set when the positioner is open. Therefore check this setting before closing the controller.



WARNING

The specifications of the examination certificate valid in your country must be observed.

Electrical connection in hazardous areas

The national directives and laws which apply in your country for hazardous areas, must be followed for electrical installations. In Germany these are, for example:

- Working reliability regulations
- Regulations for installing electrical equipment in hazardous areas, DIN EN 60079-14 (in the past VDE 0165, T1).
- The EC type examination certificates



WARNING

If the intrinsically safe version is operated with a higher operating voltage by mistake, the positioner must no longer be used for intrinsically safe application.

The explosion-proof positioner may only be supplied with electrical power in areas in which the atmosphere may be potentially explosive when the housing is closed. Where power supply is required, we recommend checking the power supply to ensure that it corresponds with that on the name plate and with the test certification valid for your country.

The feed-through openings in the explosion-proof version for the electronic connections must be sealed with EEX-d certified cable glands or EEx-d certified plugs or an ignition lock must be mounted at a maximum distance of 46 cm (18 inches) when using the “conduit”-system.

The plastic housing is metal lined to increase the electromagnetic compatibility (EMC) against high frequency radiation. This screen is connected electrically to the threaded bushes shown in figure 3-12, page 58.

Please bear in mind that this protection can only be effective if you connect at least one of these bushes with grounded fittings by electrically conductive (blank) mounting parts.

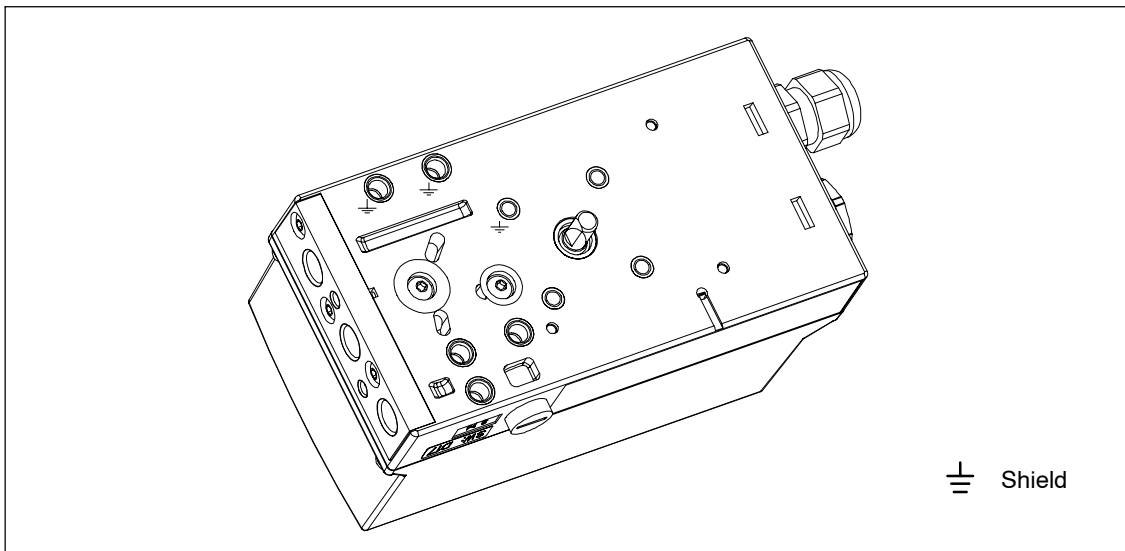

Figure 3-12 Base plate



NOTE

Use standard M20 x 1.5 cable gland nuts to ensure leakage (IP-protection of the housing) and for the necessary tensile strength use only cables with a cable diameter ≥ 8 mm, or for smaller diameters use a suitable sealing insert.

For the NPT version, the positioner will be delivered with an adapter. Make sure that when fitting a part into the adapter, that the maximum permissible torque of 10 Nm is not exceeded.

NOTE for use in zone 2:

Non-sparking equipment for Zone 2 may not be connected or disconnected under power in normal operation.

However, during installation or repair work the positioner may be connected or disconnected even under power (see also certificate for zone 2).

NOTE for use in two-wire systems:

Never connect the current input (terminal 6 and 7) to a voltage source as this could destroy the positioner.

Always use a current source with a maximum output current of 20 mA.

To maintain the power supply, the input current must be ≥ 3.6 mA.

www.DataSheet4U.com

3.4.1 Connection in non-intrinsically safe and explosion proof version

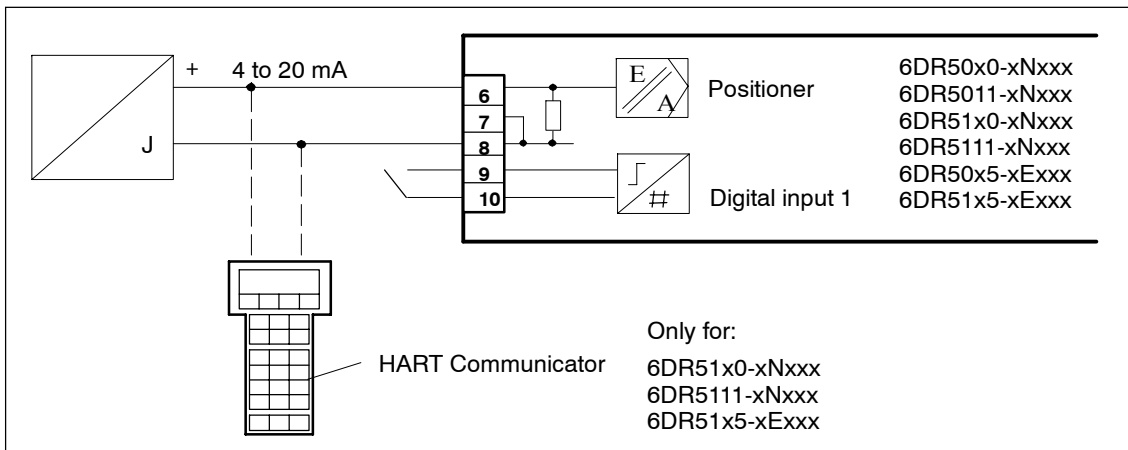

Figure 3-13 Two-wire connection

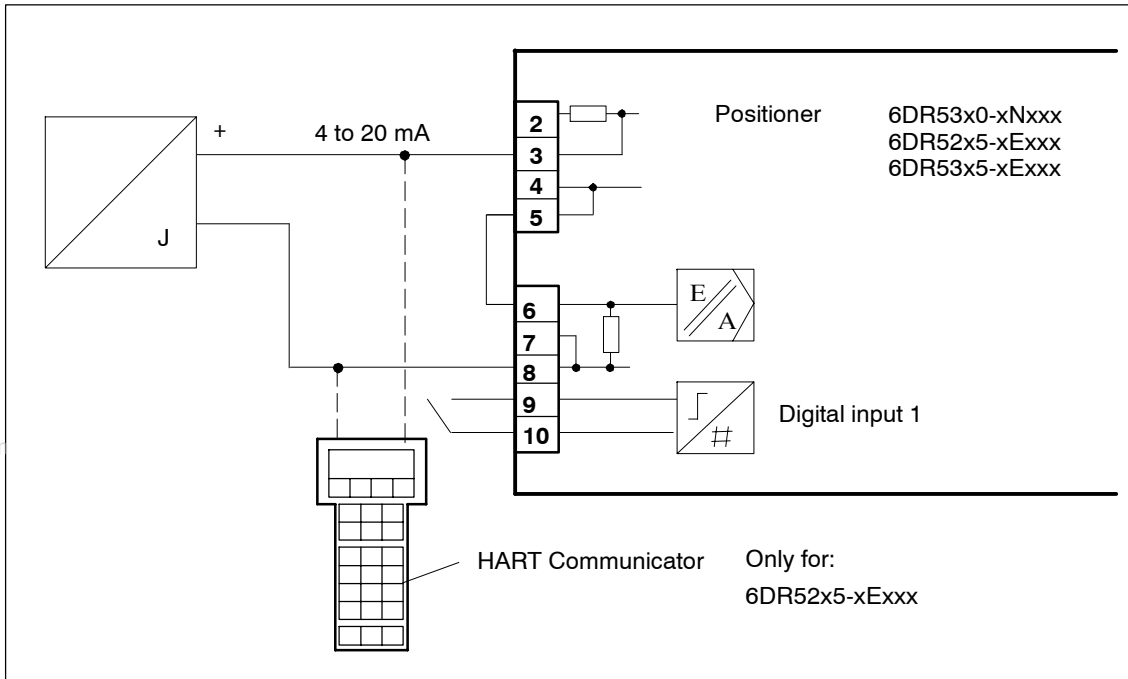

Figure 3-14 Two-wire connection

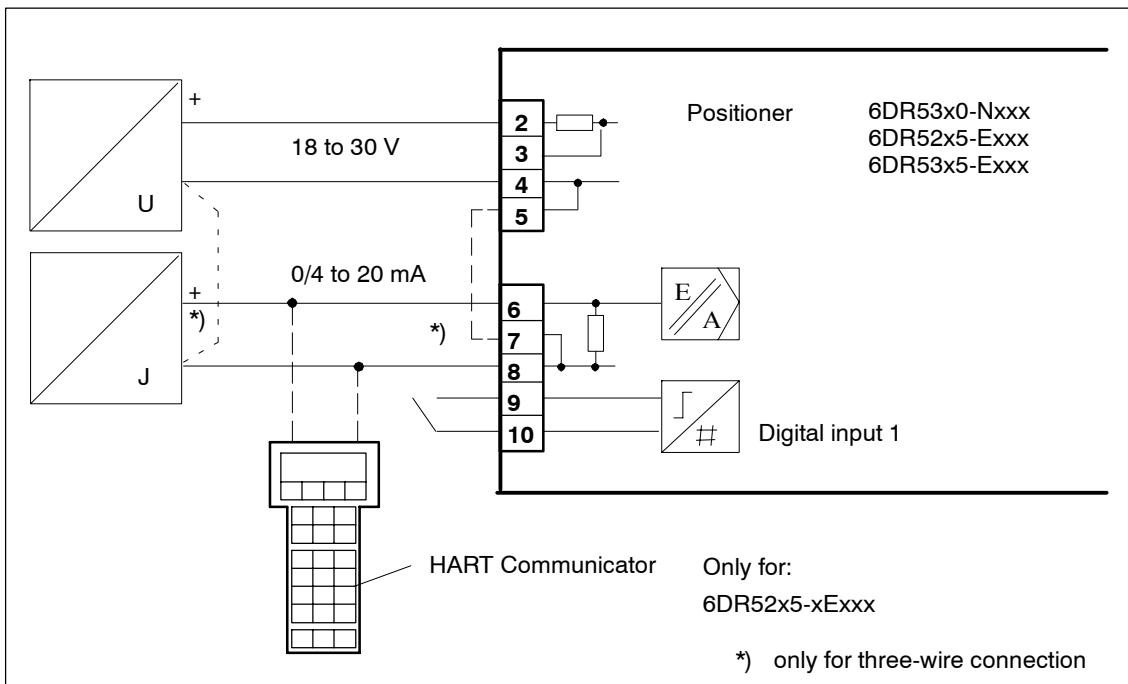

Figure 3-15 Three-/four-wire connection

Current output

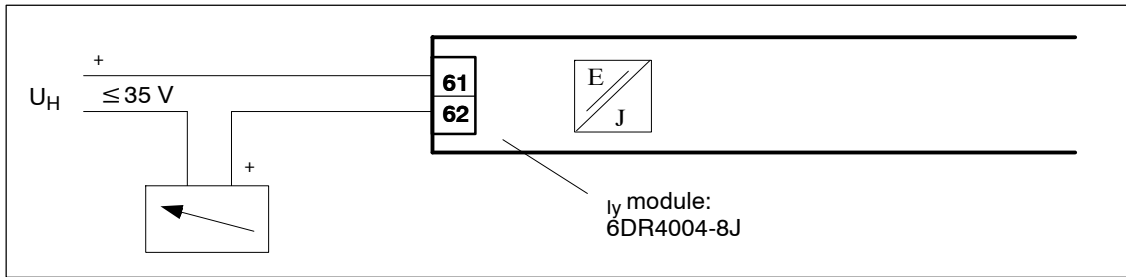

Figure 3-16 I_y module 6DR4004-8J, not Ex

www.DataSheet4U.com

Digital inputs and outputs

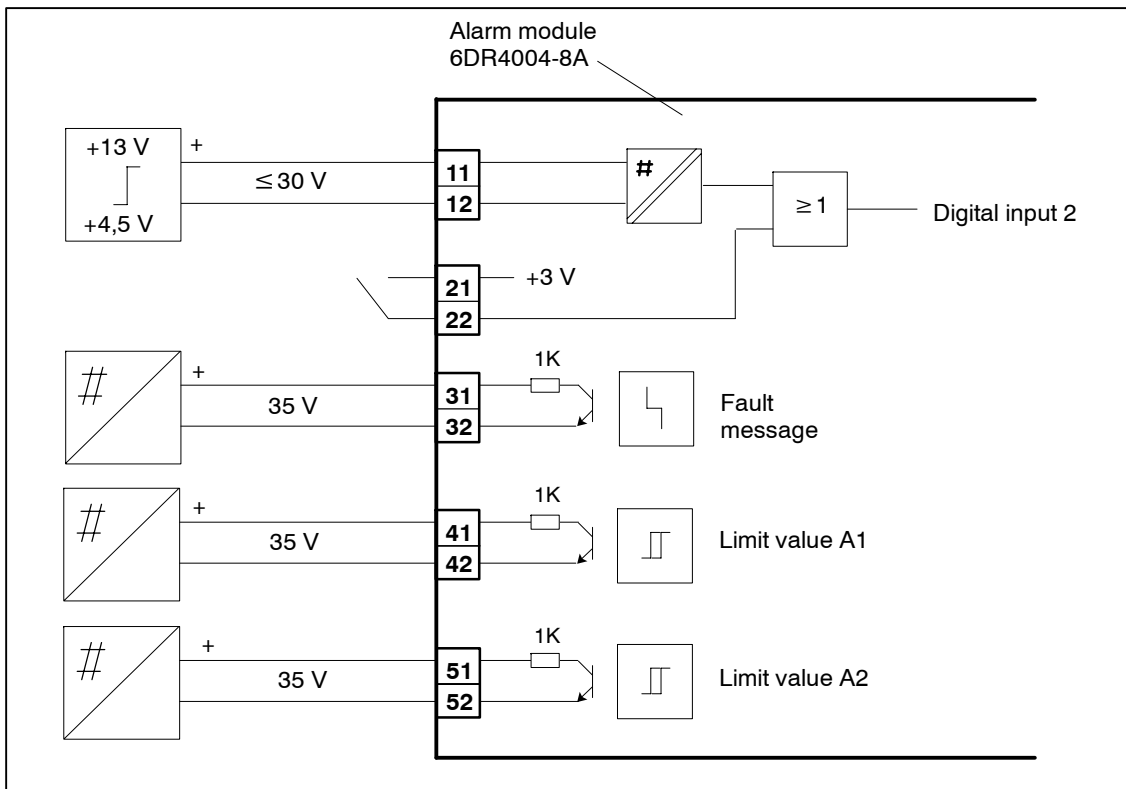

Figure 3-17 Alarm module 6DR4004-8A, not Ex

SIA module

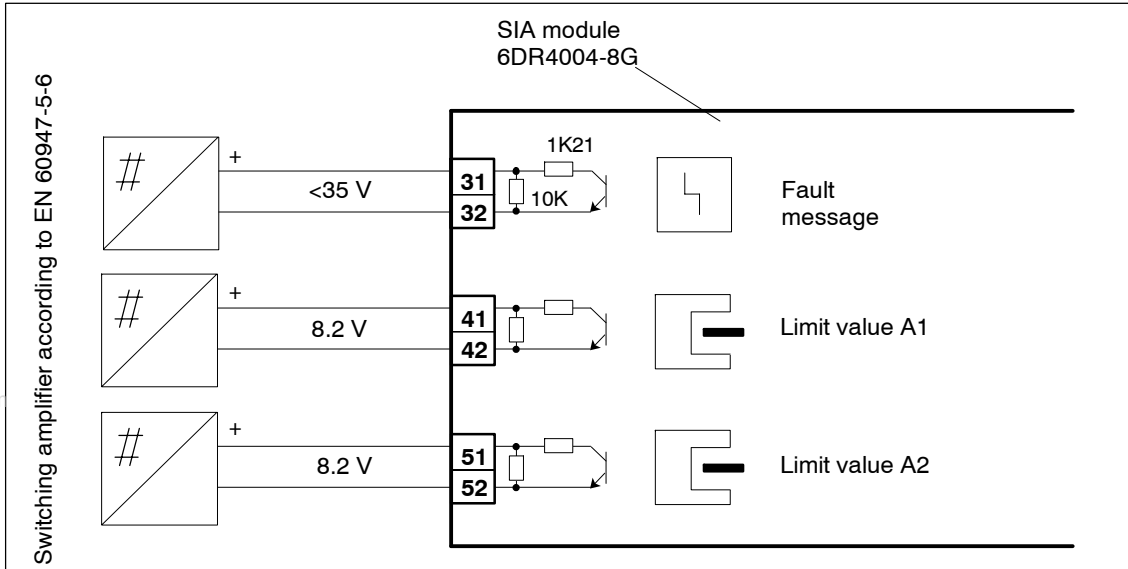

Figure 3-18 SIA module 6DR4004-8G, not Ex

Mechanical limit switch module

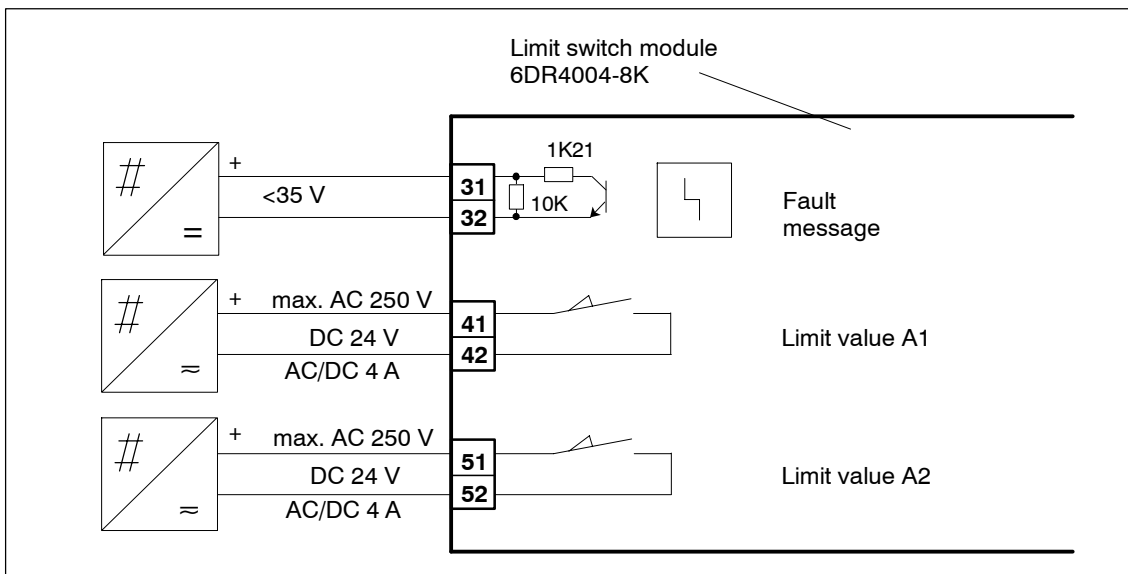

Figure 3-19 Mechanical limit switch module 6DR4004-8K, not Ex

3.4.2 Connection in intrinsically safe version



NOTE

Only certified intrinsically safe circuits may be connected as power supply, control and signal circuits.

Standard controller

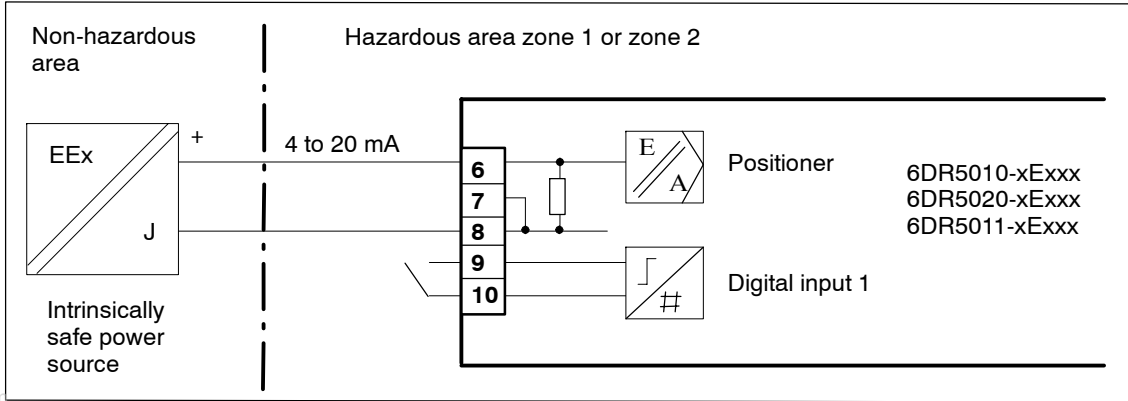

Figure 3-20 Two-wire connection, EEx i

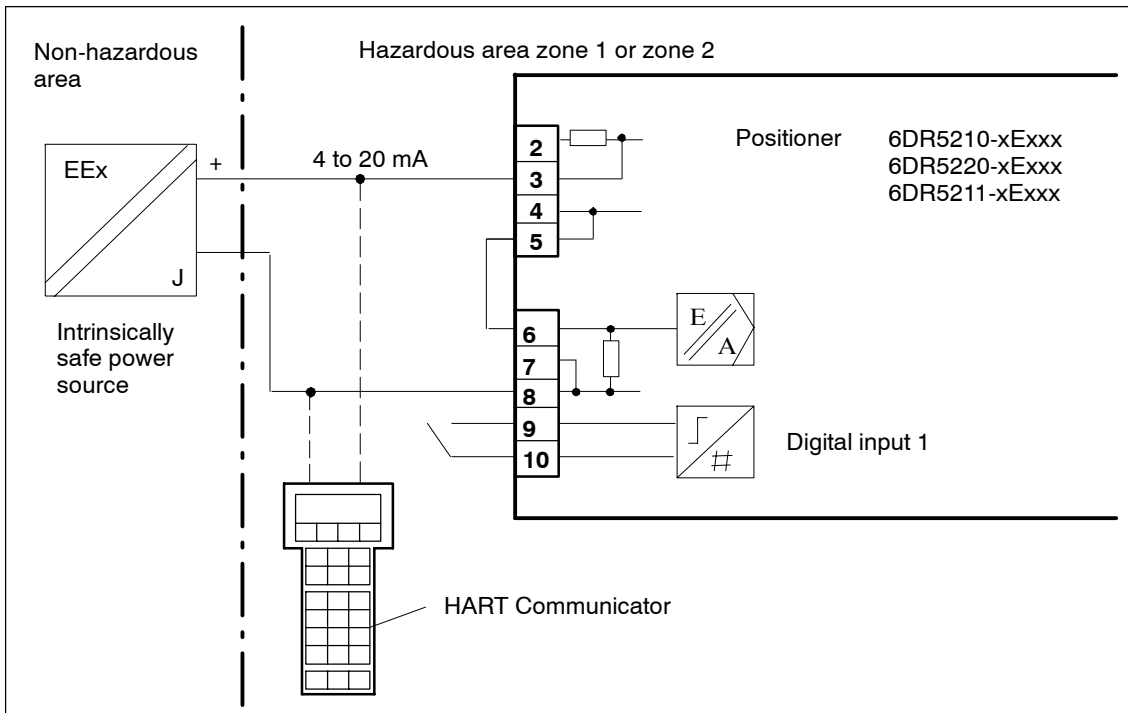

Figure 3-21 Two-wire connection, EEx i

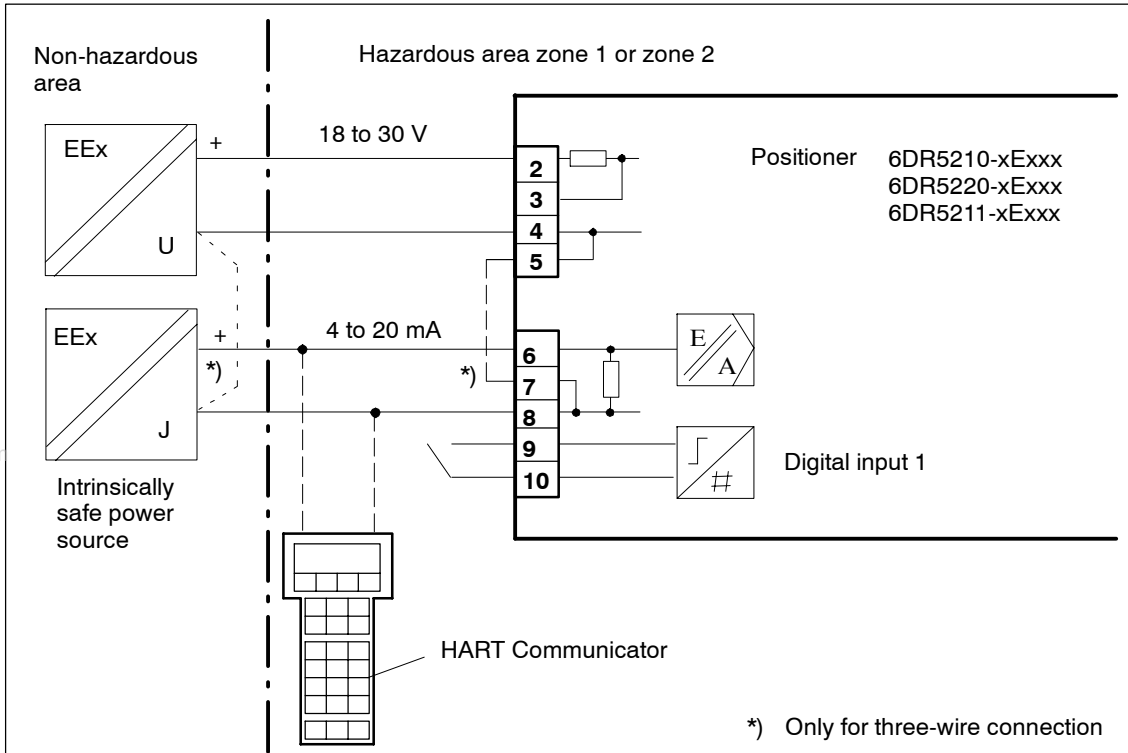

Figure 3-22 Three-/four-wire connection, EEx i

Split-range

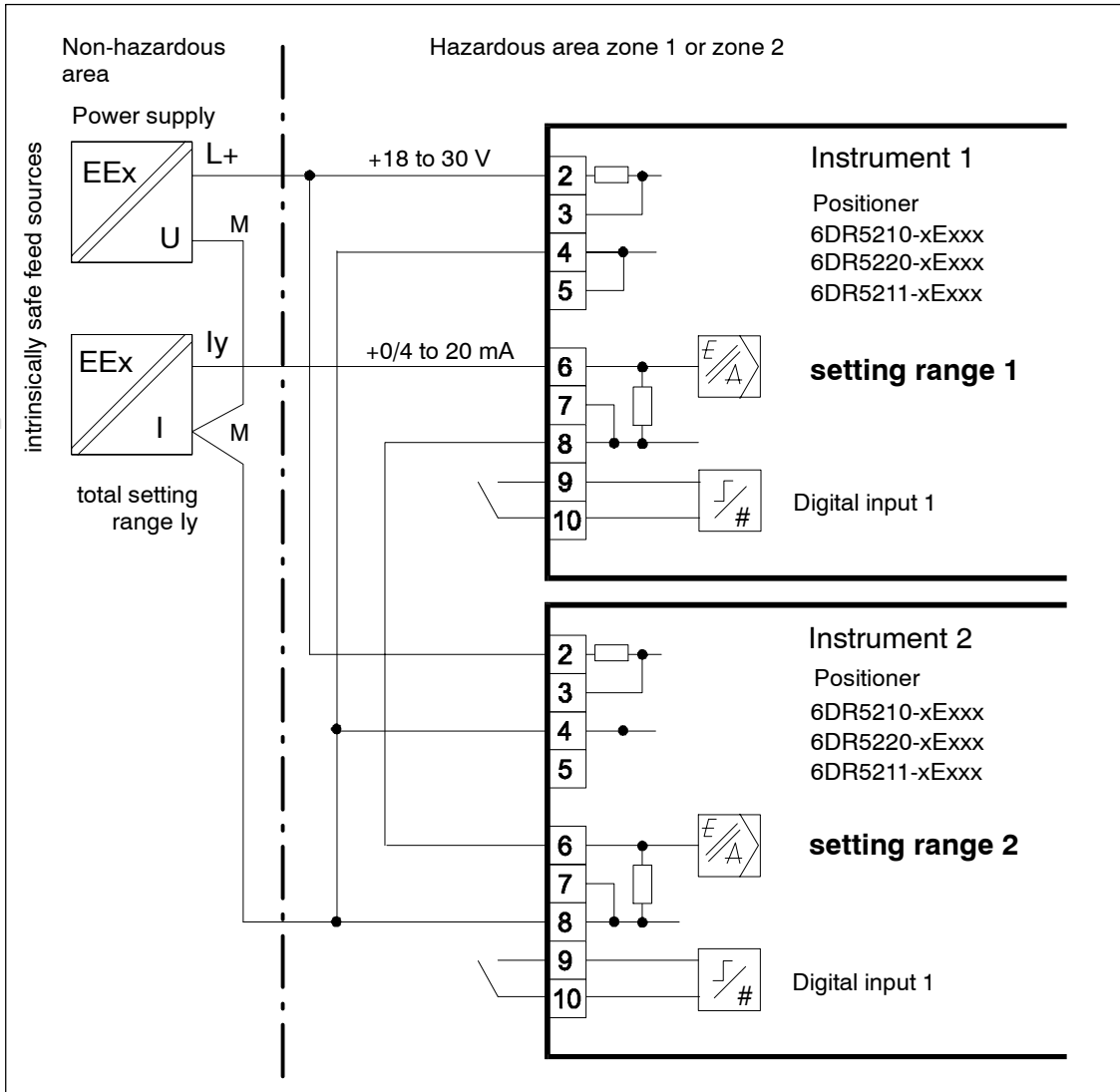

Figure 3-23 Series circuit of two positioners, e.g. split range (separate power supply), EEx i

Current output

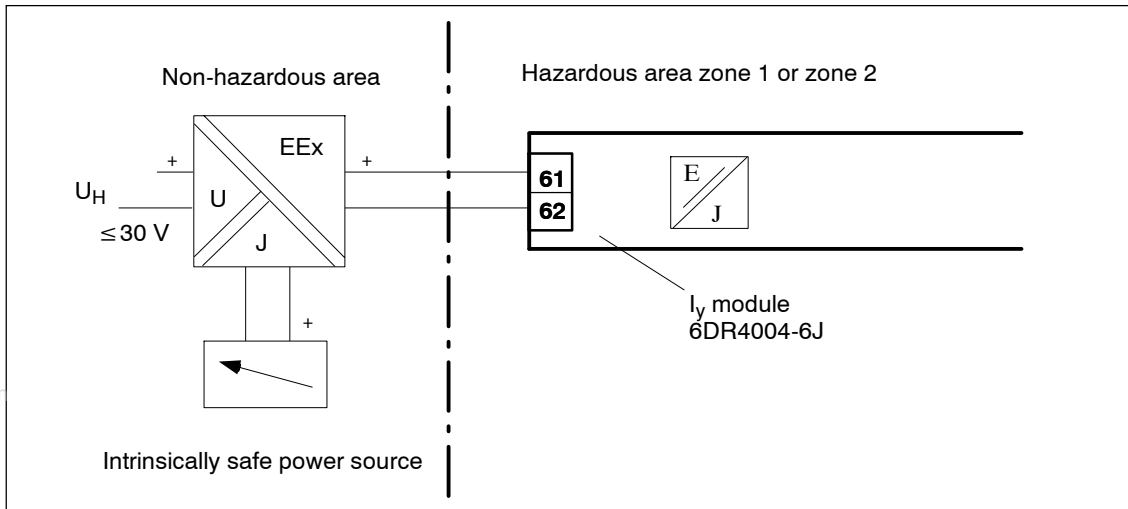

Figure 3-24 I_y-module 6DR4004-6J, EEx i

Digital inputs and outputs

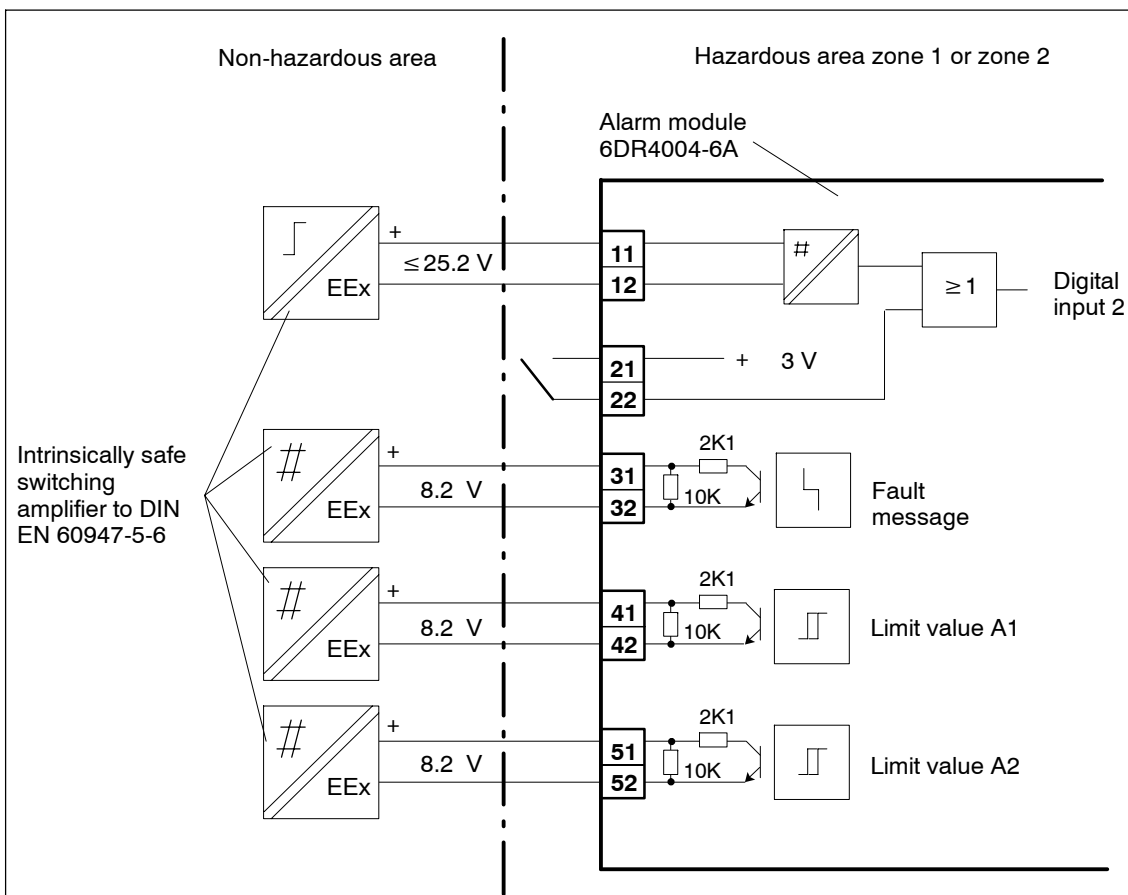

Figure 3-25 Alarm module 6DR4004-6A, EEx i

SIA module

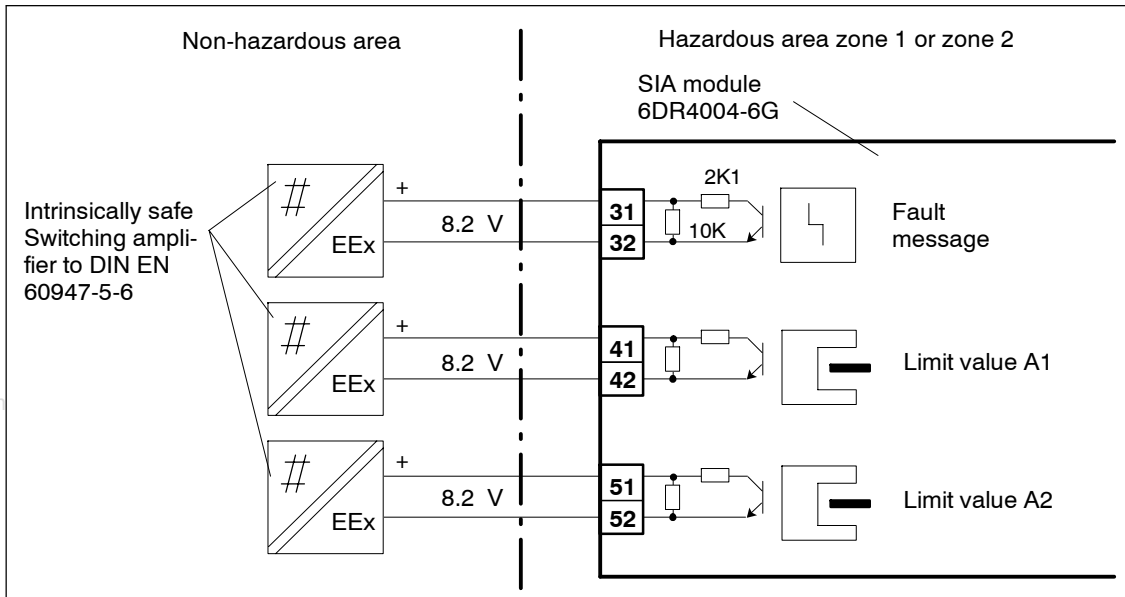

Figure 3-26 SIA module 6DR4004-6G, EEx i

Mechanical limit switch module

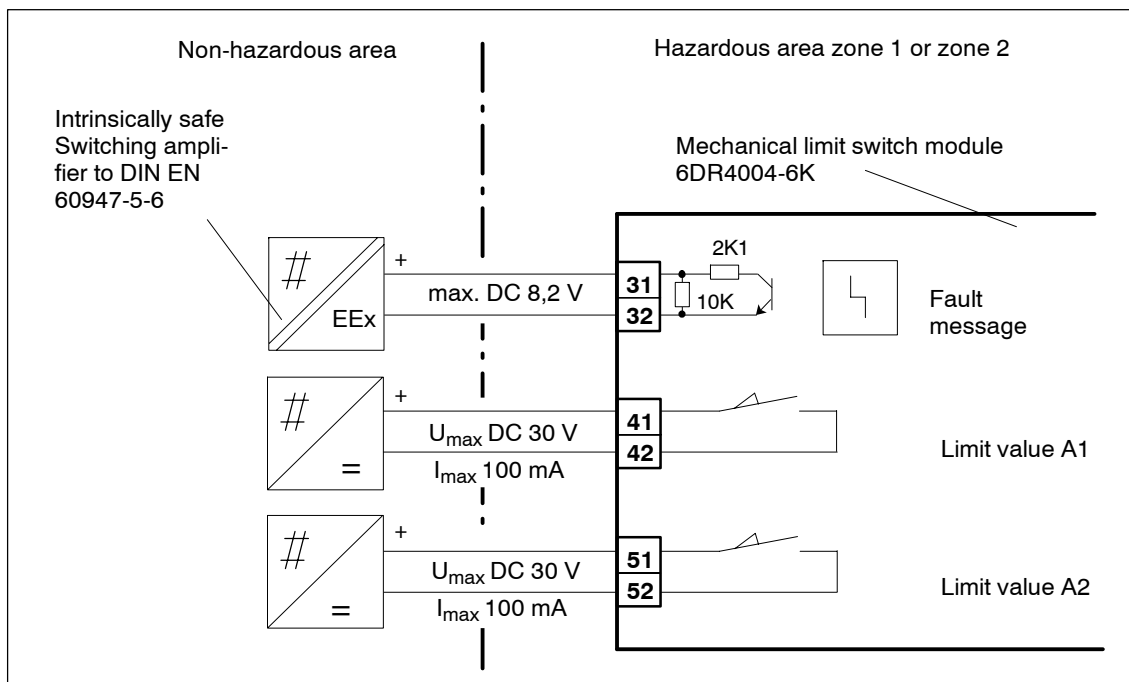

Figure 3-27 Mechanical limit switch module 6DR4004-8K, EEx i

3.4.3 Connection in type of protection “n” version

Standard controller

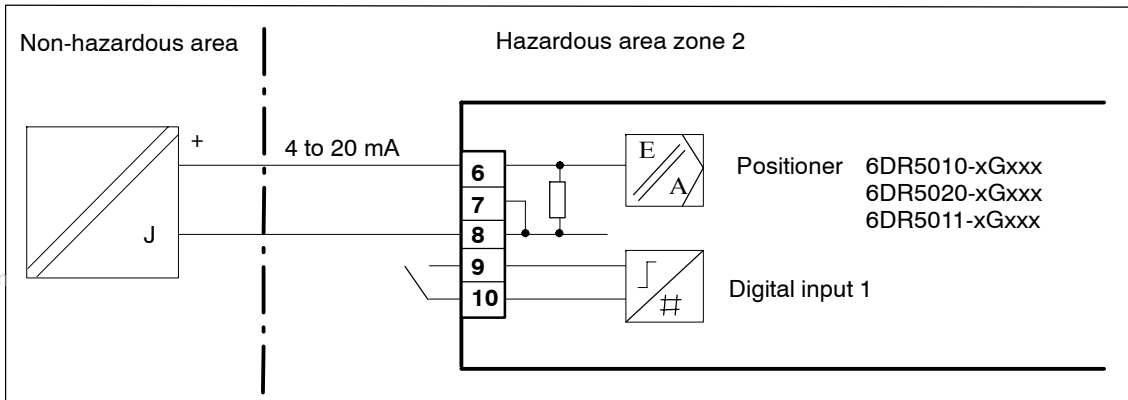

Figure 3-28 Two-wire connection, EEx n

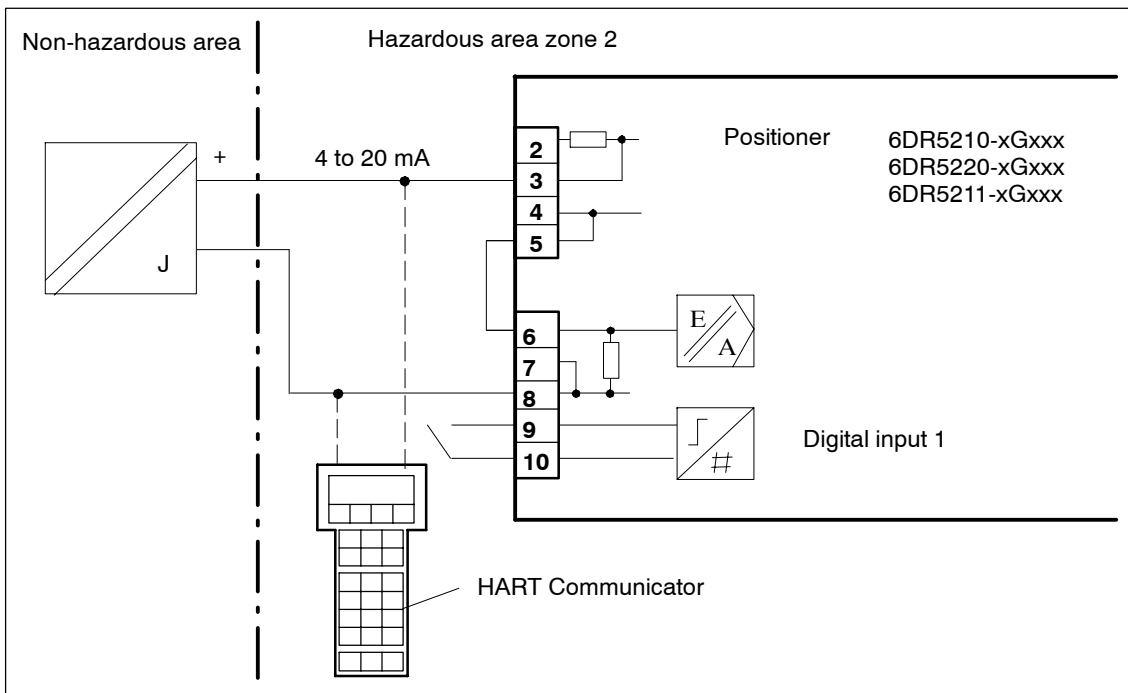

Figure 3-29 Two-wire connection, EEx n

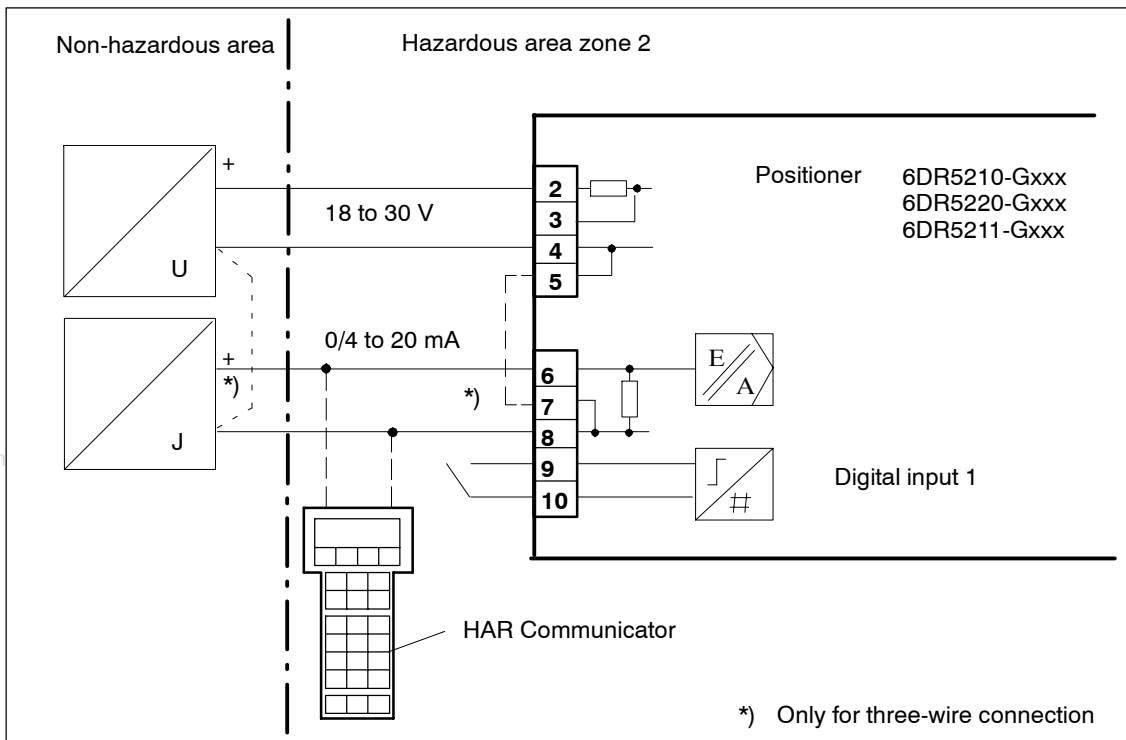

Figure 3-30 Three-/Four-wire connection, EEx n

Current output

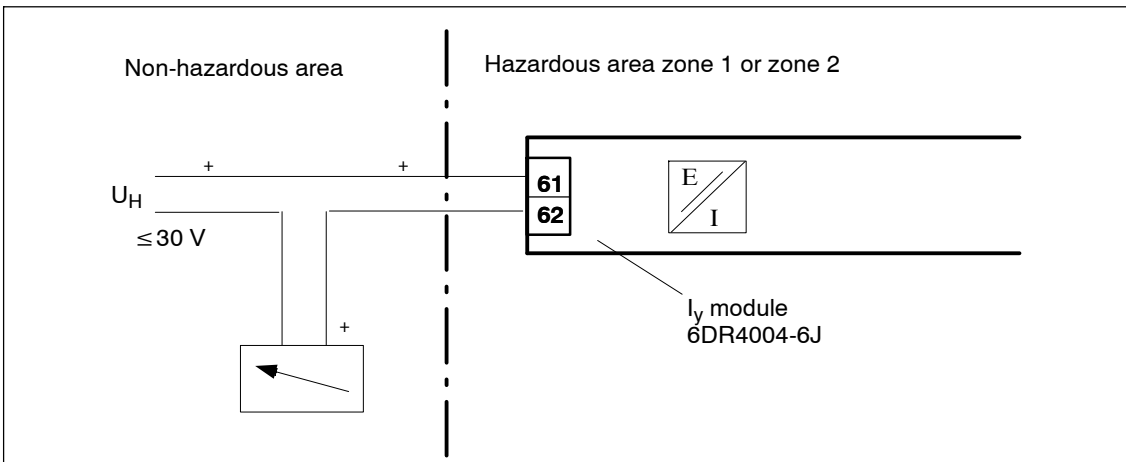

Figure 3-31 I_y -module 6DR4004-6J, EEx n

Digital inputs and outputs

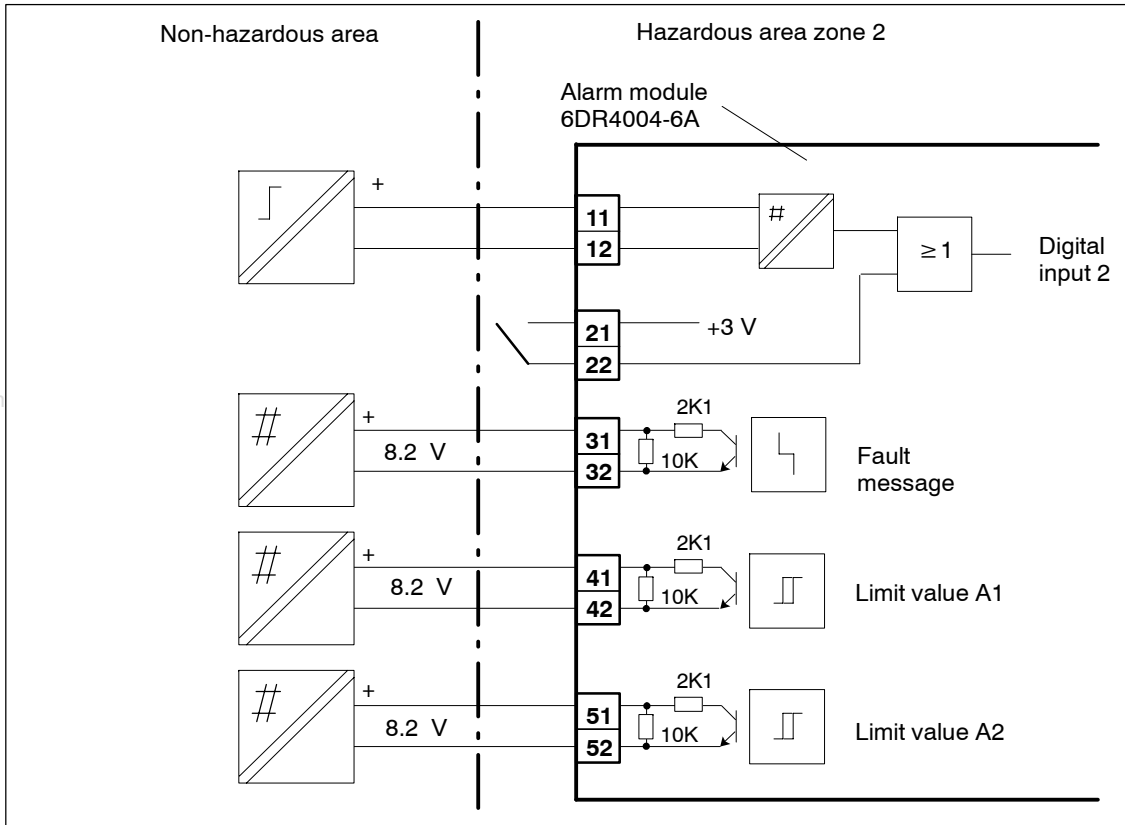

Figure 3-32 Alarm module 6DR4004-6A, EEx n

SIA module

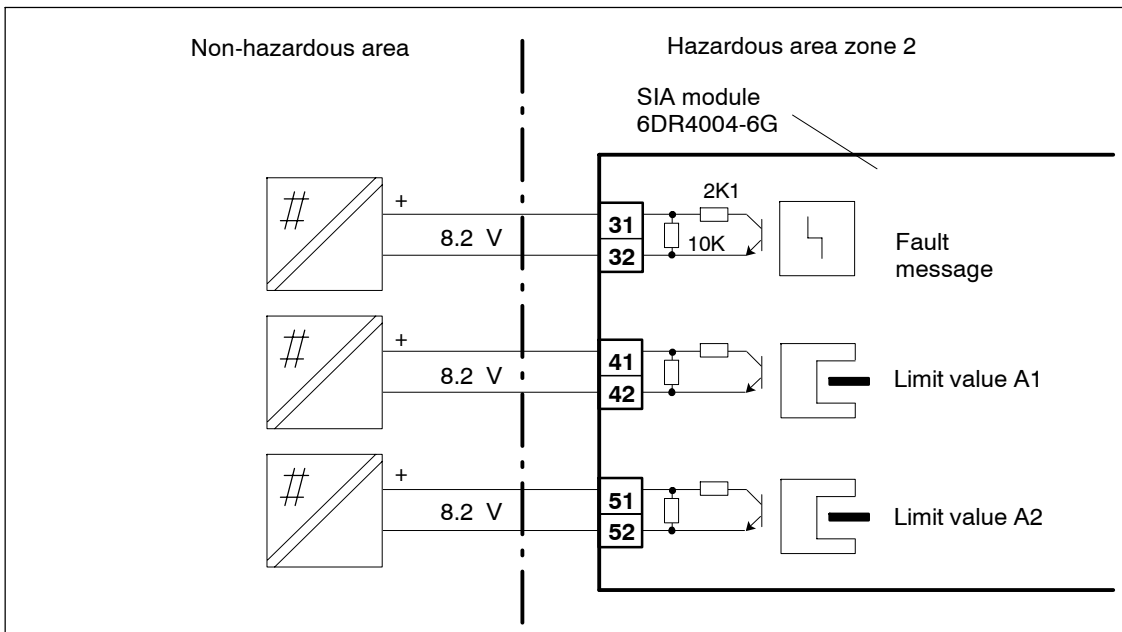

Figure 3-33 SIA module 6DR4004-6G, EEx n

3.5 Pneumatic Connection



WARNING

For reasons of safety, the pneumatic power may only be supplied after assembly when the positioner is switched to operating level P manual operation with electrical signal applied (as-delivered state, see figure 4-4, page 92).



NOTE

Note the air quality! Oil-free industrial air, solid content < 30 μm , pressure dew point 20 K below the lowest ambient temperature (chapter 7 “Technical Data”, page 153).

- Connect a manometer block for supply air and actuating pressure if necessary.
- Connection by female thread G 1/4 DIN 45141 or 1/4" NPT:

P _Z	Supply air 1.4 to 7 bar
Y1	Actuating pressure 1 for single- and double-acting actuators
Y2	Actuating pressure 2 for double-acting actuators
E	Exhaust air outlet (remove silencer if necessary)

 see figure 2-4 and 2-5, page 19.
- Safety position when the electric power supply fails:

single-acting:	Y1	deaerated
double-acting:	Y1	Max. Actuating pressure (supply air pressure)
	Y2	deaerated
- Connect actuating pressure Y1 or Y2 (only in double-acting actuators) according to the desired safety position.
- Connect supply air to P_Z.



NOTE

In order for spring-loaded pneumatic actuators to be able to reliably exploit the maximum possible travel, the supply pressure must be sufficiently greater than the maximum required final pressure of the actuator.

After installing the device, check the pneumatic connections of the entire assembly for leakage. Any leakage would cause not only continuous consumption of compressed air but also would cause the positioner to continually endeavor to compensate for the variance in position, leading in time to premature wear of the whole control mechanism.

3.6 Commissioning

Once the positioner has been fitted to a pneumatic actuator, it must be provided with electrical and pneumatic auxiliary power.

Then you can then adapt the position controller to the respective actuator by parameterizing and initializing it.

Mode" operating mode (which can also if necessary be attained by "PRST") – "NOINI" will flash.

If the positioner has not been initialized it will be in the "P Manual Mode" operating mode (which can also if necessary be attained by "PRST") – "NOINI" will flash.

This initialization can be effected in three different ways:

- **Automatic initialization**
Initialization takes place automatically. Hereby the positioner determines the direction of action, the stem travel and the angle of rotation, the travel times of the actuator one after the other and adapts the control parameters to the dynamic behavior of the actuator.
- **Manual initialization**
The stem travel or angle of rotation of the actuator can be set manually, the other parameters are determined as in automatic initialization. This function is useful in actuators with soft limit stops.
- **Copying initialization data (positioner exchange)**
In the devices with HART function the initialization data of a positioner can be read out and copied to another positioner. This enables a defective device to be changed without having to interrupt an ongoing process by initialization.

Only a few parameters need to be set in the positioner prior to initialization. The others are defaulted so that they do not normally need to be adjusted. You will have no problems with commissioning if you observe the following points.

The possible operating modes and parameters, together with the adjustment capabilities and their effects are described in chapter 4, page 89 "Operation".



NOTE

N.B.: The operating pressure should be at least one bar greater than is necessary for closing/opening the valve during initialization. However, the operating pressure may not be higher than the maximum permissible operating pressure of the actuator.

N.B.: The transmission ratio selector can only be set when the positioner is open. Therefore check this setting before closing the housing.

3.6.1 Preparations for linear actuators

1. Assemble the positioner with the appropriate mounting kit (see chapter 3.3.3, page 39).



NOTE

Particularly important is the position of the transmission ratio selector (8, figure 2-2, page 17) in the positioner:

Stroke	Lever	Position of the transmission ratio selector
5 to 20 mm	short	33° (i.e. down)
25 to 35 mm	short	90° (i.e. up)
40 to 130 mm	long	90° (i.e. up)

www.DataSheet4U.com

2. Push the carrier pin (4, figure 3-7 (page 51) 2) onto the lever (6, figure 3-7, 2) to the scale position corresponding to the rated stroke or next highest position and screw the carrier pin tight with the nut (18, figure 3-7, 2).
3. Connect the actuator and the positioner with the pneumatic lines and supply pneumatic power to the positioner (figure 2-4 and 2-5, page 19).
4. Connect a suitable current or voltage source (see figure 3-13, page 59 and figure 3-20, page 63).
5. The positioner is now in the operating mode "**P-manual operation**". The current potentiometer voltage (P) is displayed in percent in the top line of the display, e.g.: "**P12.3**", and "**NOINI**" flashes in the bottom line:

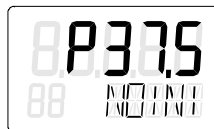

6. Check the free running of the mechanics in the whole actuating range by moving the actuator with the keys \triangle and ∇ and driving to the respective end position.



NOTE

You can move the actuator quickly by pressing the other direction key additionally whilst keeping the direction key selected first pressed.

7. Now move the actuator to the horizontal position of the lever. A value between **P48.0** and **P52.0** should be visible in the display. If this is not the case, adjust the friction clutch (8, figure 2-11, page 28 or in frameproof enclosure 8, figure 2-12, page 31) until "**P50.0**" is displayed with a horizontal lever. The more accurately you hit this value, the more exactly the positioner can determine the path.

NOTICE

for the explosion-proof version:

Only adjust the outer friction clutch (8, Fig. 2-12, page 31). The internal friction clutch (8, Fig. 2-11 page 28) is fixed and, for the explosion-proof version, must **not** be adjusted.

3.6.2 Automatic initialization of linear actuator

www.DataSheet4U.com

If you can move the actuator correctly, leave it standing in a central position and start automatic initialization:

1. Press the operation mode key  for longer than 5 s. This brings you to the Configuration mode.
Display:



2. Switch to the second parameter by pressing the operation mode key  briefly.
Display:

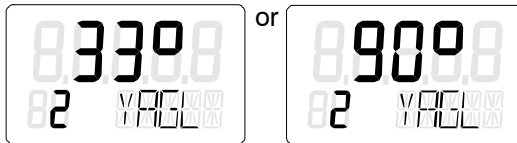

NOTE

It is vital that this value corresponds to the setting of the transmission ratio selector (8, figure 2-2, page 17) (33° or 90°).

3. Switch on to the following display with the operation mode key :

You only need to set this parameter if you want to have the total stroke in mm displayed at the end of the initialization phase. To do this, select the same value in the display to which you have set the carrier pin to the scale on the lever.

4. Switch on to the following display with the operation mode key :



5. Start initialization by pressing the key  for longer than 5 s.
Display:



During the initialization phase “RUN1” to “RUN5” appear one after another in the bottom display (see also structograms figure 3-35, page 83 to figure 3-38, page 86).



NOTE

The initialization process may last up to 15 minutes depending on the actuator.

The initialization is complete when the following display appears:



The following display appears after pressing the operation mode key  briefly:



To exit the **Configuration** mode, press the operation mode key  for longer than 5 s. The software version is displayed after about 5 s. The instrument is in manual operation after releasing the operation mode key.



NOTE

You can abort an ongoing initialization at any time by pressing the operation mode key. Your previous settings are retained. All the parameters are reset to the factory setting only after performing a “Preset”.

3.6.3 Manual initialization of linear actuator

The positioner can be initialized with this function without the actuator being driven hard against the limit stop. The start and end positions of the travel are set manually. The other initialization steps (optimization of the control parameters) run automatically as in automatic initialization.

Manual initialization procedure in linear actuator

1. Make preparations as described in chapter 3.6.1, page 73 for linear actuator. In particular, make sure by manually driving the whole travel that the displayed potentiometer setting moves in the permissible range between P5.0 and P95.0.

Press the operation mode key  for longer than 5 s. This brings you to the Configuration mode.

Display:



3. Switch to the second parameter by pressing the operation key  briefly. One of the following displays appears:

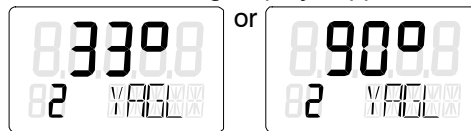

NOTE

It is vital that this value corresponds to the setting of the transmission ratio selector (33° or 90°).

4. Switch on to the following display  with the operation mode key:



You only need to set this parameter if you want to have the total stroke in mm displayed at the end of the initialization phase. To do this, select the same value in the display to which you have set the carrier pin to the scale on the lever or the next highest position in intermediate positions.

5. Switch on to the following display  by pressing the operation mode key twice:





6. Start initialization by pressing the increment key  for longer than 5 s.
Display:



7. After 5 s the display changes to:



(The display of the potentiometer setting is shown here and below as an example only).

Now move the actuator to the position which you want to define as the first of the two end positions with the increment  and decrement  key. Then press the operation mode key . This accepts the current position as end position 1 and switches on to the next position.



NOTE

If the message "RANGE" appears in the bottom line, the selected end position is outside the permissible measuring range. There are several ways to correct the error:

- Adjust the friction clutch until "OK" appears and press the operation mode key again or
- move to another end position with the increment and decrement key or
- abort initialization by pressing the operation mode key. You then have to change to P manual operation and correct the travel and the position detection according to step 1.

8. If step 7 was successful, the following display appears:



Now move the actuator to the position which you want to define as the second end position with the increment Δ and decrement ∇ key. Then press the operation mode key \square . This enters the current position as end position 2.



NOTE

If the message "RANGE" appears in the bottom line, the selected end position is outside the permissible measuring range. There are several ways to correct the error:

- move to another end position with the increment and decrement key or
- abort initialization by pressing the operation mode key. You then have to change to P manual operation and correct the travel and the position detection according to step 1.



NOTE

If the message "Set Middl" appears, the lever arm must be driven to horizontal position using the increment and decrement key and then the operation mode key pressed. This sets the reference point of the sine correction in linear actuators.

9. The rest of the initialization now runs automatically. "RUN1" to "RUN5" appear one after another in the bottom line of the display. The following display appears on successful completion of initialization:



The first line additionally contains the determined stroke in millimeters if the set lever length was specified with parameter 3 YWAY.

5 INITM appears in the bottom line again after pressing the operation mode key \square briefly. This brings you back to the Configuration operating mode.

To exit the Configuration mode, press the operation mode key \square for longer than 5 seconds. The software version is displayed after about 5 seconds. The instrument is in manual operation after releasing the operation mode key.

3.6.4 Preparations for part-turn actuator



NOTE

Very important: Switch the transmission ratio selector in the positioner (8, figure 2-2, page 17) to position 90° (normal angle for part-turn actuator).

1. Mount the positioner with the appropriate mounting kit (see chapter 3.3.5, page 52).
2. Connect the actuator and the positioner with the pneumatic lines and supply pneumatic power to the positioner (figure 2-4 and 2-5, page 19).
3. Connect a suitable current or voltage source (see figure 3-13, page 59 and figure 3-20, page 63).
4. The positioner is now in the operating mode "**P-manual operation**". The current potentiometer voltage (P) is displayed in % in the top line of the display, e.g.: "**P12.3**", and "**NOINI**" flashes in the bottom line:



5. Check the free running of the mechanics in the whole actuating range by moving the actuator with the keys \triangle and ∇ and driving to the respective end position.



NOTE

You can move the actuator quickly by pressing the other direction key additionally whilst keeping the direction key selected first pressed.

3.6.5 Automatic initialization of part-turn actuator

If you can move the actuator correctly through the actuating range, leave it standing in a central position and start automatic initialization:

1. Press the operation mode key  for longer than 5 s. This brings you to the configuration operating mode.

Display



- Set the parameter with the ∇ -key to "turn"
Display:



- Switch to the second parameter by pressing the operation mode key \square briefly. This has set automatically to 90°.
Display:



- Switch on to the following display with the operation mode key \square :



- Start initialization by pressing the key \triangle for longer than 5 s.
Display:



During the initialization phase "RUN1" to "RUN5" appear one after another in the bottom display (see also structograms in figure 3-35, page 83 to figure 3-38, page 86).



NOTE

The initialization process may last up to 15 minutes depending on the actuator.

The initialization is complete when the following display appears:



The top value indicates the total angle of rotation of the actuator (example 93.5°).

The following display appears after pressing the operation mode key \square briefly:

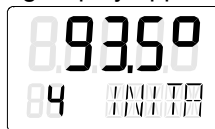

To exit the **Configuration** mode, press the operation mode key  for longer than 5 s. The software version is displayed after about 5 s. The instrument is in manual operation after releasing the operation mode key.



NOTE

You can abort an ongoing initialization at any time by pressing the operation mode key. Your previous settings are retained. All the parameters are set to the factory setting only after performing a “Preset”.

3.6.6 Manual initialization of part-turn actuators

The positioner can be initialized with this function without the actuator being driven hard against the limit stop. The start and end positions of the travel are set manually. The other initialization steps (optimization of the control parameters) run automatically as in automatic initialization.

Manual initialization procedure in part-turn actuators

1. Make preparations as described in chapter 3.6.4, page 79 for part-turn actuators. In particular, make sure by manually driving the whole travel that the displayed potentiometer setting moves in the permissible range between P5.0 and P95.0.
2. Press the operation mode key  for longer than 5 s. This brings you to the Configuration mode.
Display:



3. Set the parameter YFACT to “turn” with the decrement  key.
Display:



4. Switch to the second parameter by pressing the operation mode key  briefly.
Display:





NOTE

Make sure that the transmission ratio selector is in position 90 °!

5. Switch on to the following display by pressing the operation mode key  twice:



The following steps are identical with the steps 6) to 9) for initialization of linear actuators.

After successful initialization the determined part-turn range appears in the top display.

“5.INITM” appears in the bottom line again after pressing the operation mode key  briefly. This brings you back to the Configuration mode.

To exit the Configuration mode, press the operation mode key  for longer than 5 seconds. The software version is displayed after about 5 seconds. The instrument is in manual operation after releasing the operation mode key.

3.6.7 Automatic initialization (structograms)

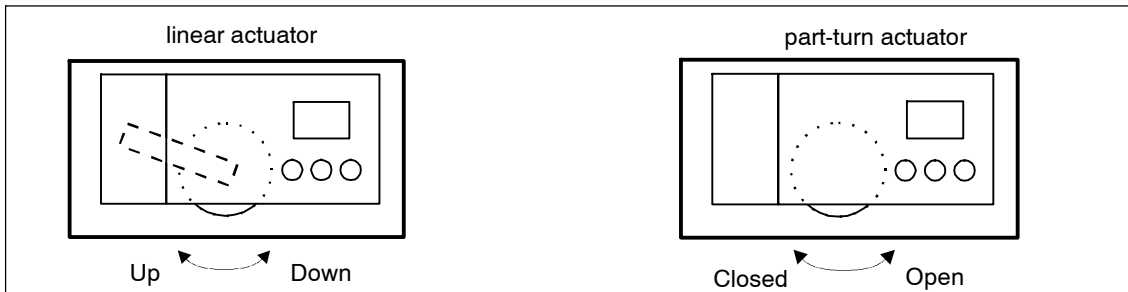

Figure 3-34 Direction of action of the actuators

The initialization procedure should be taken from the following structogram (figure 3-35 to figure 3-38). The terms Open/Closed and up/down in the structogram refer to the direction of action of the actuators as illustrated in figure 3-34.

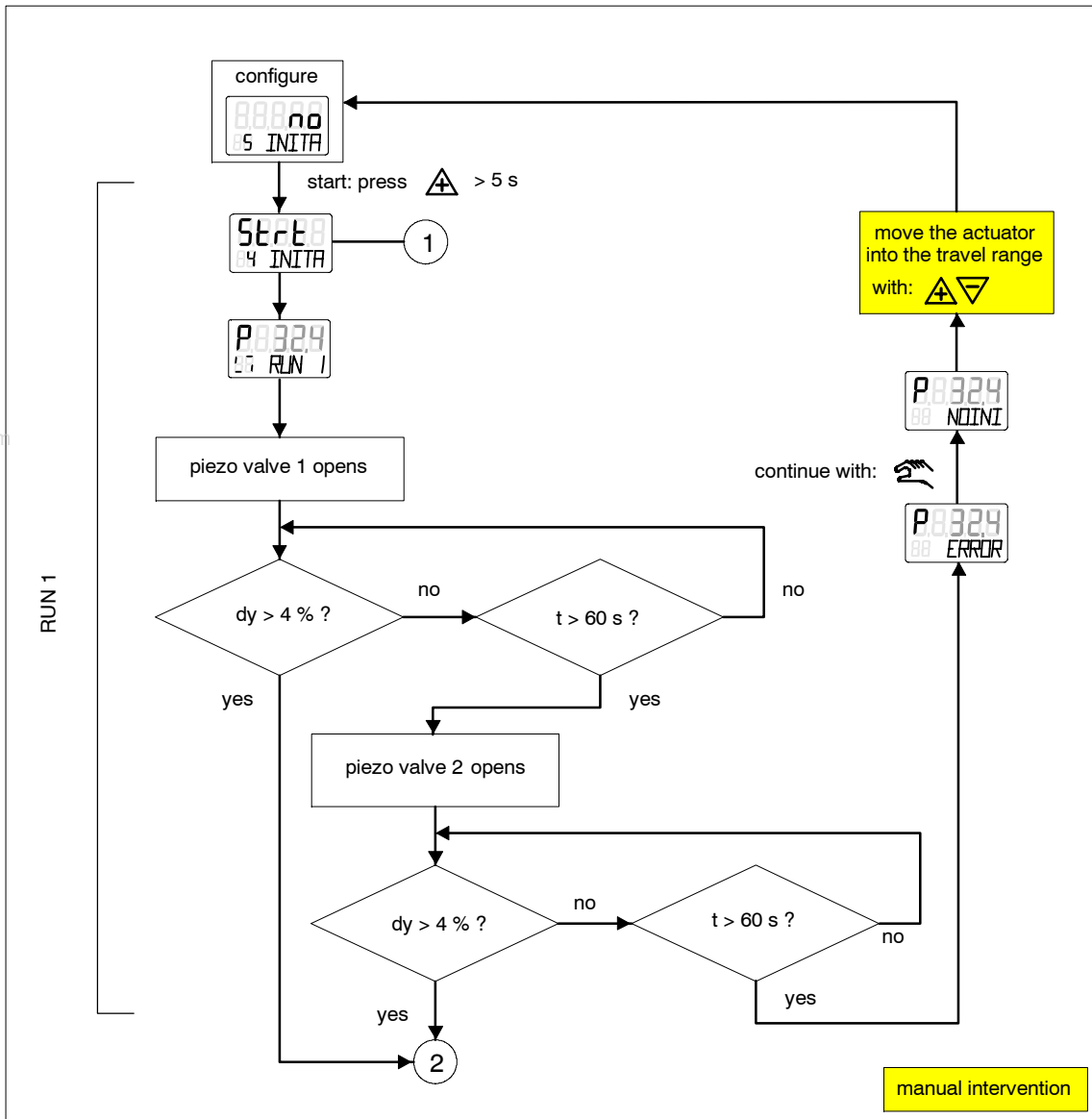

Figure 3-35 Automatic initialization, part 1

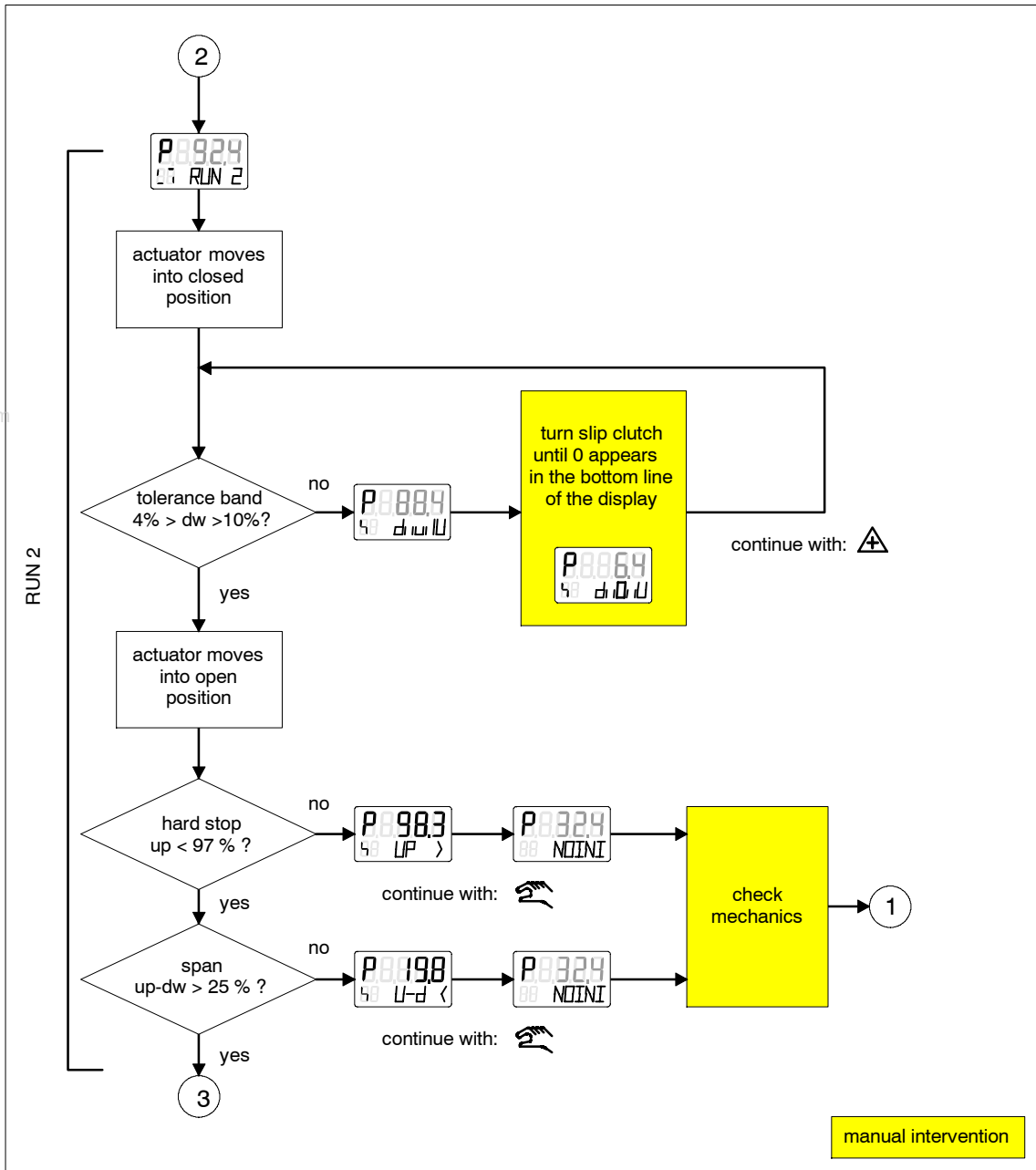

Figure 3-36 Automatic initialization part 2 (in part-turn actuators)

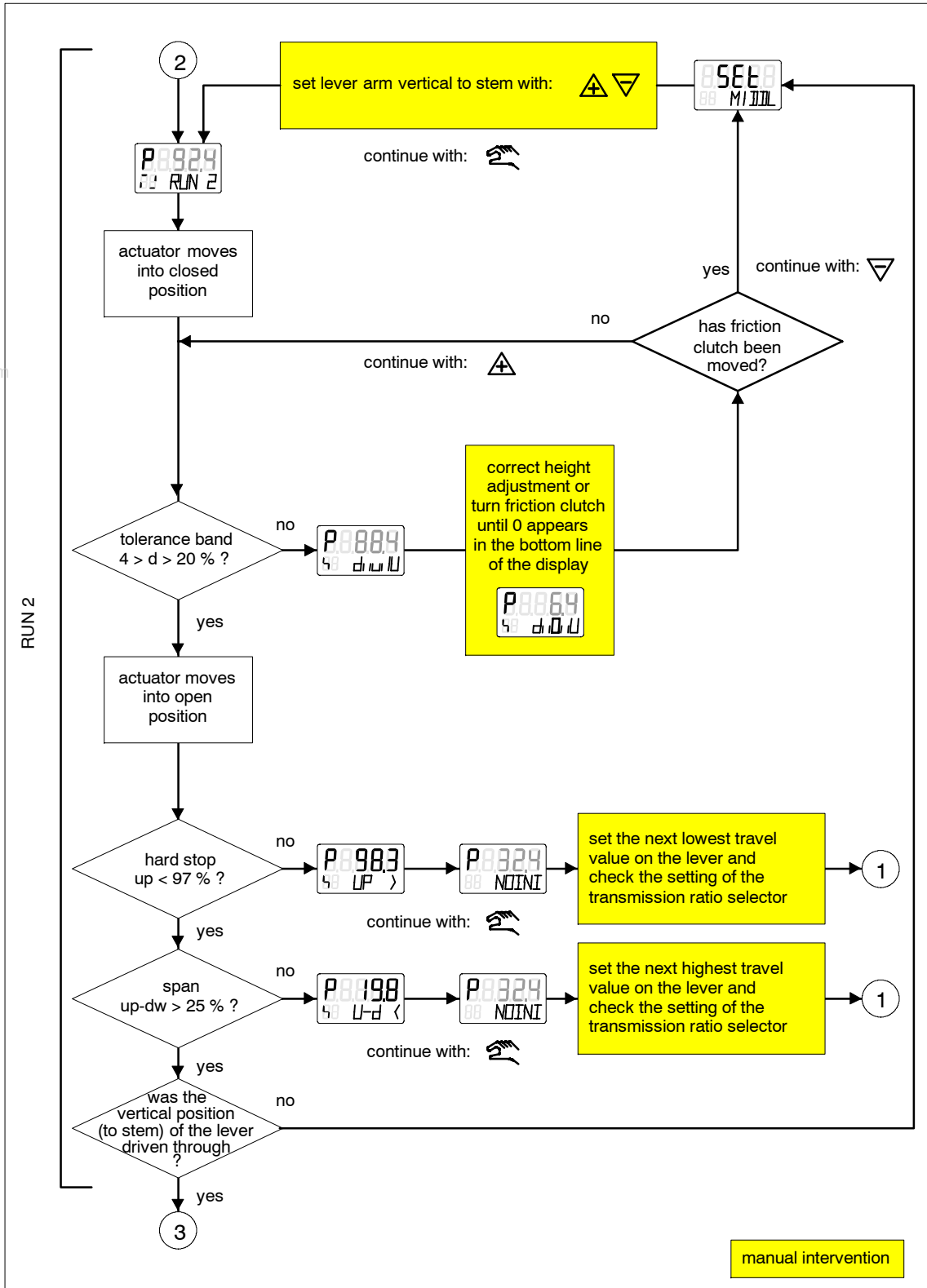

Figure 3-37 Automatic initialization part 2 (in linear actuators)

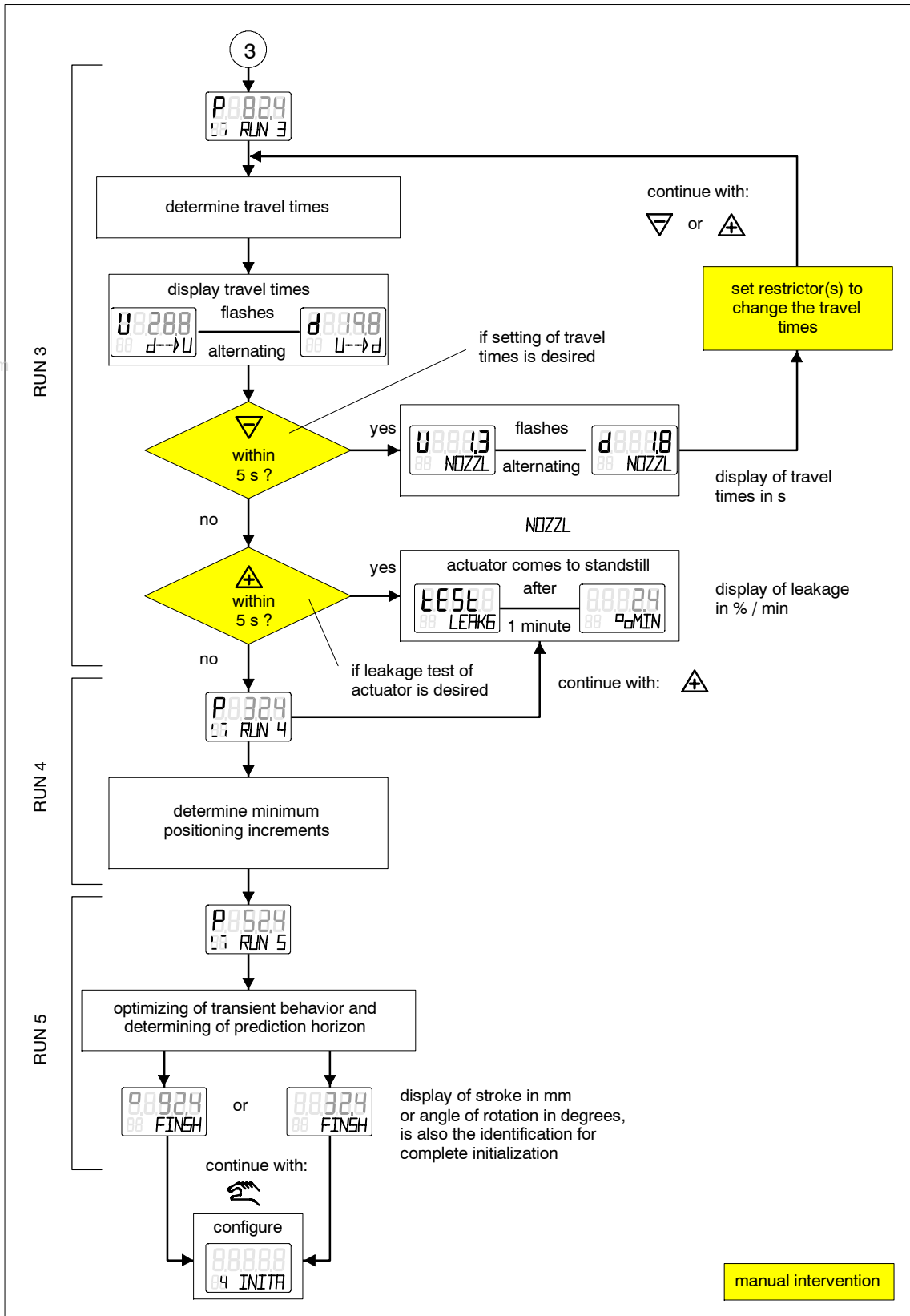

Figure 3-38 Automatic initialization, part 3

3.7 Copying initialization data (positioner exchange)

With this function you have the possibility of starting up a positioner without running the initialization routine. This allows for example a positioner to be changed on a running system in which automatic or manual initialization cannot be performed without disturbing the process.

NOTICE

Initialization (automatic or manual) should be performed as soon as possible afterwards because only then can the positioner be optimally adapted to the mechanical and dynamic properties of the actuator.

Data are transmitted from the positioner to be replaced to the replacement instrument via the HART®- communication interface.

The following steps must be performed to exchange a positioner:

1. Read in and save instrument parameters and initialization data (determined in initialization) of the instrument to be replaced with PDM (**P**rocess **D**evice **M**anager). This step is unnecessary if the instrument has been parameterized with PDM and the data have already been stored.
2. Fix the actuator in its momentary position (mechanical or pneumatic).
3. Read and note the current position actual value of the positioner to be changed. If the electronics are defective, determine the current position by measuring on the actuator or valve.
4. Disassemble the positioner. Mount the lever arm of the positioner on the replacement instrument. Mount the replacement instrument on the fitting. Move the transmission ratio selector to the same position as the defective instrument. Copy the instrument data and initialization data from the PDM or handheld.
5. If the displayed actual value does not match the noted value of the defective positioner, set the correct value with the friction clutch.
6. The positioner is now ready to operate.

The accuracy and dynamic behavior may be restricted in relation to correct initialization. The position of the hard stops and the related maintenance data may show deviations in particular. Therefore initialization must be performed at the earliest opportunity.

The following chapter describes the operation of the positioner.

www.DataSheet4U.com

4.1 Display

The LC display has two lines whereby the lines have different segmentation. The elements of the top line consist of 7, those of the bottom line of 14 segments. The contents of the display depend on the selected operating mode (see chapter 4.3, page 92)



NOTE

If the positioner is operated in ranges with temperatures below $-10\text{ }^{\circ}\text{C}$ the liquid crystal display becomes sluggish and the display refresh rate is reduced considerably.

Figure 4-1 shows you the various display options. The meaning of further display capabilities is detailed in chapter 4.3 page 139.

4.2 Input keys

The positioner is operated by three keys (figure 4-2, page 91) the function of which depends on the selected operating mode. In the explosion proof version of the positioner the input keys are underneath a key cover which can be lifted up after loosening the cover screw.



NOTE

The input keys of the explosion proof version must be covered to prevent liquid getting in. The IP66/NEMA4x degree of protection is not guaranteed when the housing is open or the key cover is open.

The housing cover must be removed to operate the keys in the normal and intrinsically safe versions of the positioners.

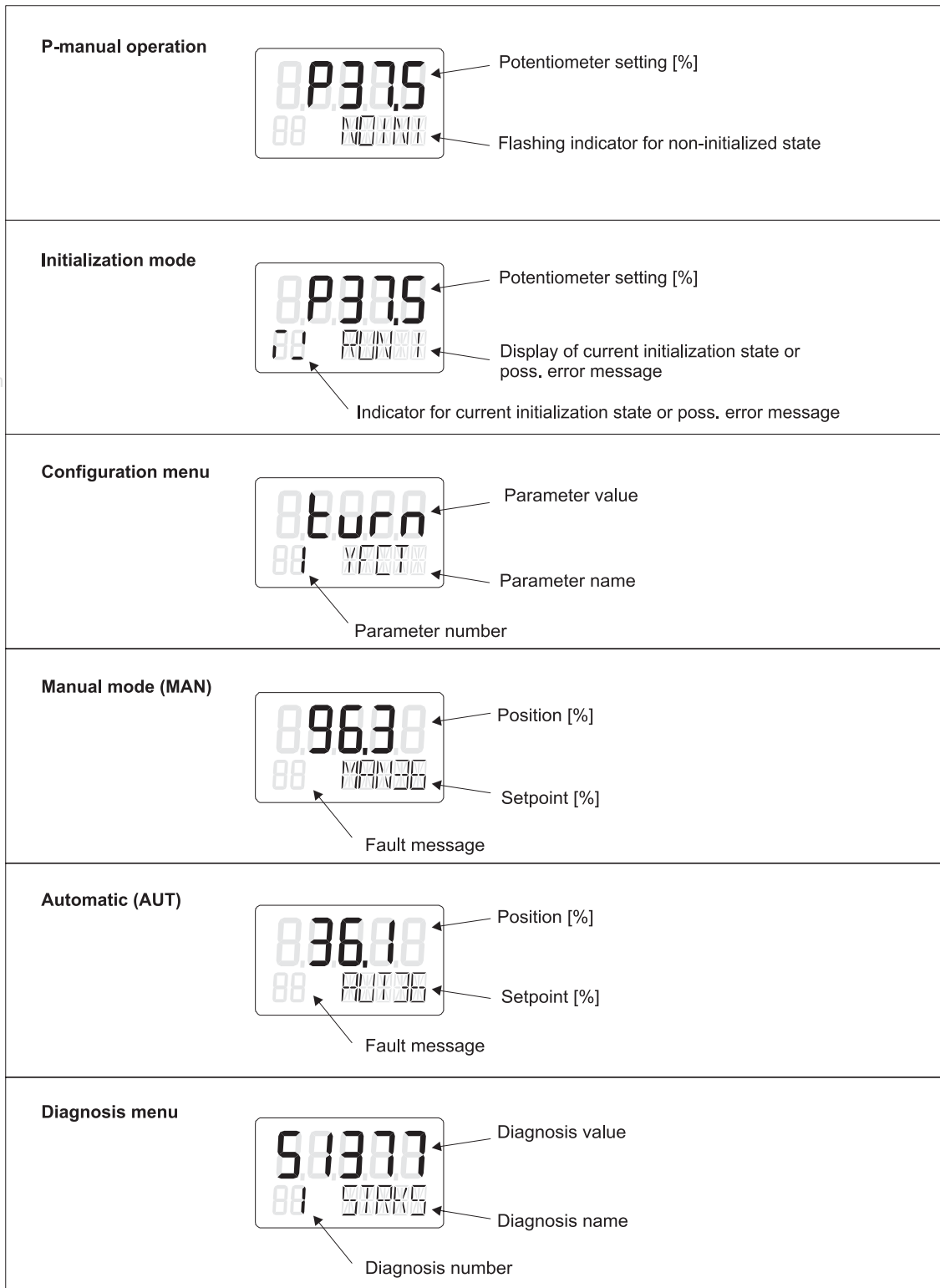
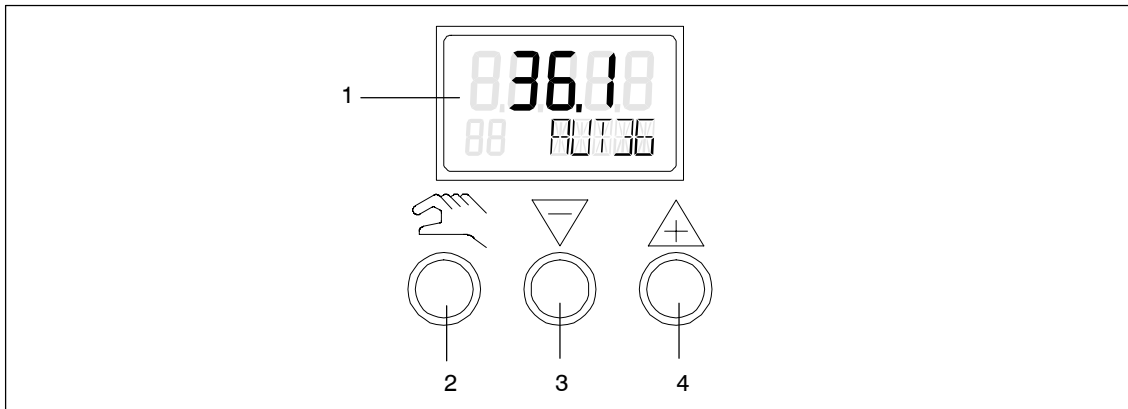

Figure 4-1 Meaning of the various display options



NOTE

The degree of protection IP 66/NEMA4x is not guaranteed as long as the positioner is open.



- 1 Display
 2 Operation mode key
 3 Decrement key
 4 Increment key

Figure 4-2 Display and input keys of the positioner

Explanations of the input keys.

- The operation mode key (manual key) serves to switch over the operating mode and pass on parameters.



NOTE

By pressing and holding the operation mode key and additionally pressing the decrement key, you can select the parameters in reverse order.

- The decrement key ∇ serves to select parameter values in configuration and to move the actuator in manual operation.
- The increment key \triangle serves to select parameter values in configuration and to move the actuator in manual operation.

Firmware version

The current firmware state is displayed when you exit the configuration menu.

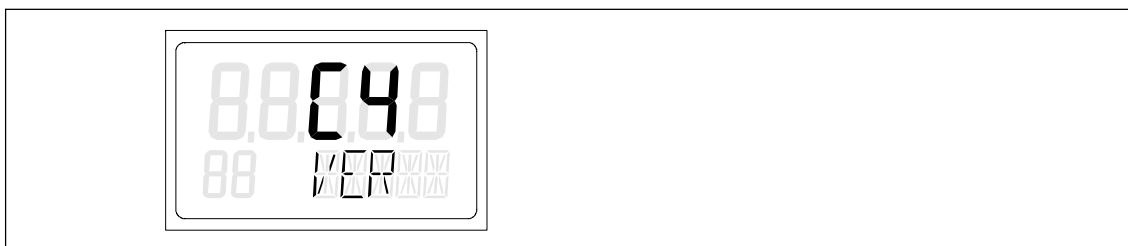

Figure 4-3 Firmware version, example: 4.00.00

4.3 Operating modes

The positioner can be operated in five operating modes.

1. P-manual mode (ex-factory state)
2. Configuration and initialization
3. Manual mode (MAN)
4. Automatic (AUT)
5. Diagnostic display

Figure 4-4 gives you an overview of the possible operating modes and the change between them.

www.DataSheet4U.com

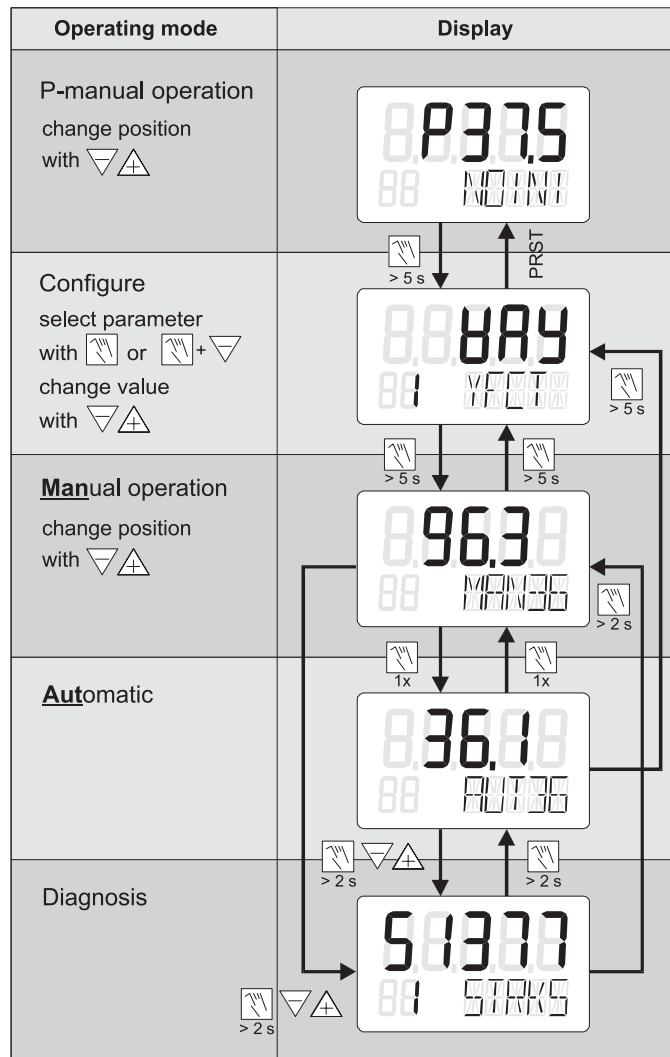



Figure 4-4 Change between the operating modes

**P-manual mode
(ex-factory state)**

The display of the positioner shows you the current potentiometer setting in the top line and “NOINIT” flashes in the second line. You can move the actuator with the decrement and increment key . In order to adapt the positioner to your actuator, you have to change to the Configuration menu. See also chapter 3.6, page 72 “Commissioning”.

Output of alarms and position feedback is possible after successful initialization.

**Configuration and
initialization**

To go to the Configuration menu, press the operation mode key  for at least 5 seconds. In the Configuration menu you can adapt the positioner individually to your actuator and start initialization. Only a few parameters need to be set in the positioner prior to initialization. The others are defaulted so that they do not normally need to be adjusted. You can block the Configuration menu against manipulation by an appropriately parameterized and activated digital input. Which parameters you need to set and all other parameters are explained in chapter 4.4, page 95 Parameters.

The configuration mode can be reported by outputting a parameterizable fault message, a position feedback or output of limit values A1 and A2 is not possible.

**NOTE**

If the electric power supply fails during configuration, the positioner switches back to the first parameter after recovering the power supply, values which have already been parameterized are retained. When doing this, please note that the new value will only be saved when leaving the configuration menu or when another parameter is selected. Without a power failure you re-enter the configuration menu at the point you exited it when you call the Configuration menu again.

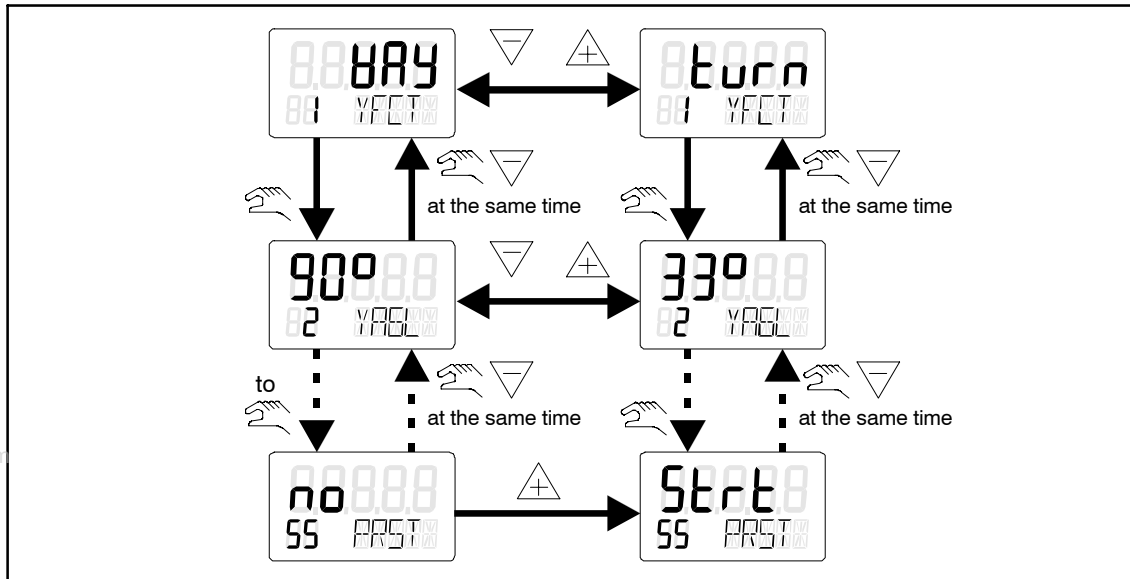

Figure 4-5 Overview: Configuration

Manual mode (MAN)

In this operating mode you can move the actuator with the decrement (▽) and increment keys (△) and the current position is held regardless of the setpoint current and any leakages.



NOTE

You can move the actuator quickly by pressing the other direction key additionally whilst keeping the direction key selected first pressed.

The manual mode can be reported by outputting a parameterizable fault message, a position feedback or output of limit values A1 and A2 is only possible in automatic mode.



NOTE

The positioner switches over to automatic mode automatically after an electrical power failure.

Automatic (AUT)

The automatic mode is the normal mode. In this mode the positioner compares the setpoint current with the current position and moves the actuator until the control deviation reaches the parameterizable dead zone. Error messages are output if this is not possible for various reasons.

Diagnostic display

In this operating mode you can have the current operating data (such as number of strokes, number of changes in direction, number of faults messages, etc.) displayed (see table 4-1, page 123).

From the automatic or manual mode you go to the diagnostic display by simultaneously pressing all three keys for at least two seconds.

See chapter 4.5, page 122 for further information.

**NOTE**

The respective operating mode (MAN or AUT) of the positioner is retained when you switch to the diagnostic display, i.e. in automatic operation the specified setpoint is still used for controlling and in manual operation the position last reached is retained.

4.4 Parameters

www.DataSheet4U.com

All the parameters of the positioner are listed in this chapter. Figure 4-6 shows an overview of the parameters.

The parameter name is shown once in plain text and once as it appears in the display. The function of the parameter is described briefly in the “Function” column. In addition, the possible parameter values, the physical unit and the factory setting of the parameters are shown.

Parameter name	Function	Parameter values (Bold = factory setting)	Unit	Parameter name	Function	Parameter values (Bold = factory setting)	Unit
1.YFCT	Type of actuator	turn (part-turn actuator) WAY (linear actuator) LWAY (linear actuator without sine correction) ncSt (part-turn actuator with NCS) -ncSt (ditto, inv. direction of action) ncSL (linear actuator with NCS) ncSLL (ditto, and lever)		A. 4 PST ⁶⁾	Partial-Stroke-Test with the following parameters:		
2.YAGL	1) Rated angle of rotation of feedback Set transmission ratio selector (7) appropriately (see view of device)	33° 90°	Degrees	A1. STPOS	Start position	0.0 ... 100.0	%
3.YWAY	2) Stroke range (optional setting)	OFF	mm	A2. STTOL	Start tolerance	0.1 ... 2.0 ... 10.0	%
	If used, the value must correspond with the set of the leverage ratio on the actuator Driver pin must be set to the value of the actuator travel or, if this value is not scaled, to the next larger scale value.	5 10 15 20 (short lever 33°) 25 30 35 (short lever 90°) 40 50 60 70 90 110 130 (long lever 90°)		A3. STEP	Step height	0.1 ... 10.0 ... 100.0	%
4.INITA	Initialization (automatically)	noini no / ### # Strt		A4. STEPD	Step direction	uP / do / uP do	days
5.INITM	Initialization (manually)	noini no / ### # Strt		A5. INTRV	Test interval	OFF / 1 ... 365	s
6.SCUR	Current range of setpoint	0 to 20 mA 4 to 20 mA	0 MA 4 MA	A6. PSTIN	Partial-Stroke-Test reference step time	noini/(C)## #Fdin/r/EAL	
7.SDIR	Setpoint direction	rising falling	rISE FALL	A7. FACT1	Factor 1	0.1 ... 1.5 ... 100.0	%
8.SPRA	Setpoint for start of split range		0.0 ... 100.0	A8. FACT2	Factor 2	0.1 ... 10.0 ... 100.0	%
9.SPRE	Setpoint for end of split range		0.0 ... 100.0	A9. FACT3	Factor 3	0.1 ... 5.0 ... 100.0	%
10.TSUP	Setpoint ramp up		Auto / 0 ... 400	b. 4 DEV ⁶⁾	Generally fault of valve with the following parameters:		
11.TSDO	Setpoint ramp down		0 ... 400	b1.TIM	Time constant	Auto / 1 ... 400	s
12.SFCT	Setpoint function	Linear	Lin	b2.LIMIT	Limit	0.0 ... 1.0 ... 100.0	%
		Equal-percentage 1.25, 1.33, 1.50 Inverse equal-percentage 1.25, 1.33, 1.50 Freely adjustable	1- 25 1- 33 1- 50 n1 - 25 n1 - 33 n1 - 50 FrEE	b3.FACT1	Factor 1	0.1 ... 5.0 ... 100.0	%
13.SL0	3) Setpoint turning point at 0%		0.0 ... 100.0	b4.FACT2	Factor 2	0.1 ... 10.0 ... 100.0	%
14.SL1	5%			b5.FACT3	Factor 3	0.1 ... 15.0 ... 100.0	%
32.SL19	to			C. 4 LEAK ⁶⁾	Pneumatic leakage with the following parameters:		
33.SL20	95%			C1.LIMIT	Limit	0.0 ... 30.0 ... 100.0	%
34.DEBA	Dead band of controller		Auto / 0.1 ... 10.0	C2.FACT1	Factor 1	0.1 ... 1.0 ... 100.0	%
35.YA	Start of manipulated variable limiting		0.0 ... 100.0	C3.FACT2	Factor 2	0.1 ... 1.5 ... 100.0	%
36.YE	End of manipulated variable limiting		0.0 ... 100.0	C4.FACT3	Factor 3	0.1 ... 2.0 ... 100.0	%
37.YNRM	Standardization of manipulated variable	To mech. travel To flow	MPOS FLOW	d. 4 STIC ⁶⁾	Stiction (Slip stick effect) with the following parameters:		
38.YDIR	Direction of manipulated variable for display and feedback	Rising Falling	rISE FALL	d1.LIMIT	Limit	0.1 ... 1.0 ... 100.0	%
39.YCLS	Tight closing with manipulated variable	Without Top only Bottom only Top and bottom	no uP do uP do	d2.FACT1	Factor 1	0.1 ... 2.0 ... 100.0	%
40.YCDO	Value for tight closing, bottom		0.0 ... 0.5 ... 100.0	d3.FACT2	Factor 2	0.1 ... 5.0 ... 100.0	%
41.YCUP	Value for tight closing, top		0.0 ... 99.5 ... 100.0	d4.FACT3	Factor 3	0.1 ... 10.0 ... 100.0	%
42.BIN1	Function of BI 1	None	OFF	E. 4 DEBA ⁶⁾	Monitoring for dead band with the following parameter:		
		Only message Block configuring Block configuring and manual Drive valve to position YE Drive valve to position YA Block movement Partial-Stroke-Test	on bLoc1 bLoc2 uP doWn StoP PST	-on -uP -doWn -StoP -PST		E1.LEVEL3	Threshold
43.BIN2	Function of BI 2	None	OFF	F. 4 ZERO ⁶⁾	Zero shift with the following parameters:		
		Only message Drive valve to position YE Drive valve to position YA Block movement Partial-Stroke-Test	on uP doWn StoP PST	-on -uP -doWn -StoP -PST		F1.LEVL1	Threshold 1
44.AFCT	5) Alarm function	Without	OFF	F2.LEVL2	Threshold 2	0.1 ... 2.0 ... 10.0	%
		A1=min. A2=max A1=min. A2=min A1=max. A2=max	normal Π ΠΠ ΠΠ ΠΠ ΠΠ ΠΠ	inverted ΠΠ ΠΠ ΠΠ	F3.LEVL3	Threshold 3	0.1 ... 4.0 ... 10.0
45.A1	Response threshold of alarm 1		0.0 ... 10.0 ... 100.0	G. 4 OPEN ⁶⁾	Shift of upper end stop with the following parameters:		
46.A2	Response threshold of alarm 2		0.0 ... 90.0 ... 100.0	G1.LEVL1	Threshold 1	0.1 ... 1.0 ... 10.0	%
47.4FCT	5) on fault Fault + not automatic Fault + not automatic + BI ("*" means logical OR operation)	normal	4 4nR 4nRb	H. 4 TMIN ⁶⁾	Monitoring for lower temperature limit with the following parameters:		
		inverted	-4 -4nR -4nRb	H1.TUNIT	Temperature unit	°C / °F	
48.4TIM	Monitoring time for fault message "control deviation"		Auto / 0 ... 100	H2.LEVL1	Threshold 1	-40 ... 90 / -40 ... 194	%
49.4LIM	Response threshold for fault message "control deviation"		Auto / 0 ... 100	H3.LEVL2	Threshold 2	-40 ... 90 / -40 ... 194	%
50.PRST	Preset (factory setting) "no" nothing activated "Strt" start of factory setting after pressing key for 5s "oCAY" display following successful factory setting CAUTION: preset results in "NO INI"		no Strt oCAY	H4.LEVL3	Threshold 3	-40 ... 90 / -40 ... 194	%
51.XDIAG	Activating for extended diagnostics	off single-stage alarm two-stage alarm three-stage alarm	OFF On1 On2 On3	J. 4 TMAX ⁶⁾	Monitoring for upper temperature limit with the following parameters:		
				J1.TUNIT	Temperature unit	°C / °F	
				J2.LEVL1	Threshold 1	-40 ... 90 / -40 ... 194	%
				J3.LEVL2	Threshold 2	-40 ... 90 / -40 ... 194	%
				J4.LEVL3	Threshold 3	-40 ... 90 / -40 ... 194	%
				L. 4 STRK ⁶⁾	Monitoring for stroke integral with the following parameters:		
				L1.LIMIT	Limit of strokes	1 ... 1 000 000	
				L2.FACT1	Factor 1	0.1 ... 1.0 ... 40.0	%
				L3.FACT2	Factor 2	0.1 ... 2.0 ... 40.0	%
				L4.FACT3	Factor 3	0.1 ... 5.0 ... 40.0	%
				O. 4 DCHG ⁶⁾	Monitoring for direction change with the following parameters:		
				O1.LIMIT	Limit of direction changes	1 ... 1 000 000	
				O2.FACT1	Factor 1	0.1 ... 1.0 ... 40.0	%
				O3.FACT2	Factor 2	0.1 ... 2.0 ... 40.0	%
				O4.FACT3	Factor 3	0.1 ... 5.0 ... 40.0	%
				P. 4 PAVG ⁶⁾	Calculation for average value of position with the following parameters:		
				P1.TBASE	Time basis for average value	0.5h / 8h / 5d / 60d / 2.5y	
				P2.STATE	Condition of calculation	IdLE / rEF / ## # / Strt	
				P3.LEVL1	Threshold 1	0.1 ... 2.0 ... 100.0	%
				P4.LEVL2	Threshold 2	0.1 ... 5.0 ... 100.0	%
				P5.LEVL3	Threshold 3	0.1 ... 10.0 ... 100.0	%

- HINTS:
- Parameter appears only if "turn" or "WAY" is selected; at "turn", you cannot select 33"
 - Parameter does not appear if "turn", "LWAY" or "ncS_" has been selected with YFCT
 - Turning points only appear with selection SFCT = "FrEE"
 - NC contact means: action with opened switch or Low level
NO contact means: action with closed switch or High level
 - Normal means: High level without fault
Inverted means: Low level without fault
 - Parameters A up to P appears only if the extended diagnostics with On1, On2 or On3 is activated. The contents of the parameters A up to P appears also only if the selected parameter is activated with On.

Figure 4-6 Parameter table of the positioner

The following configuration block diagram shows the effects of the parameters.

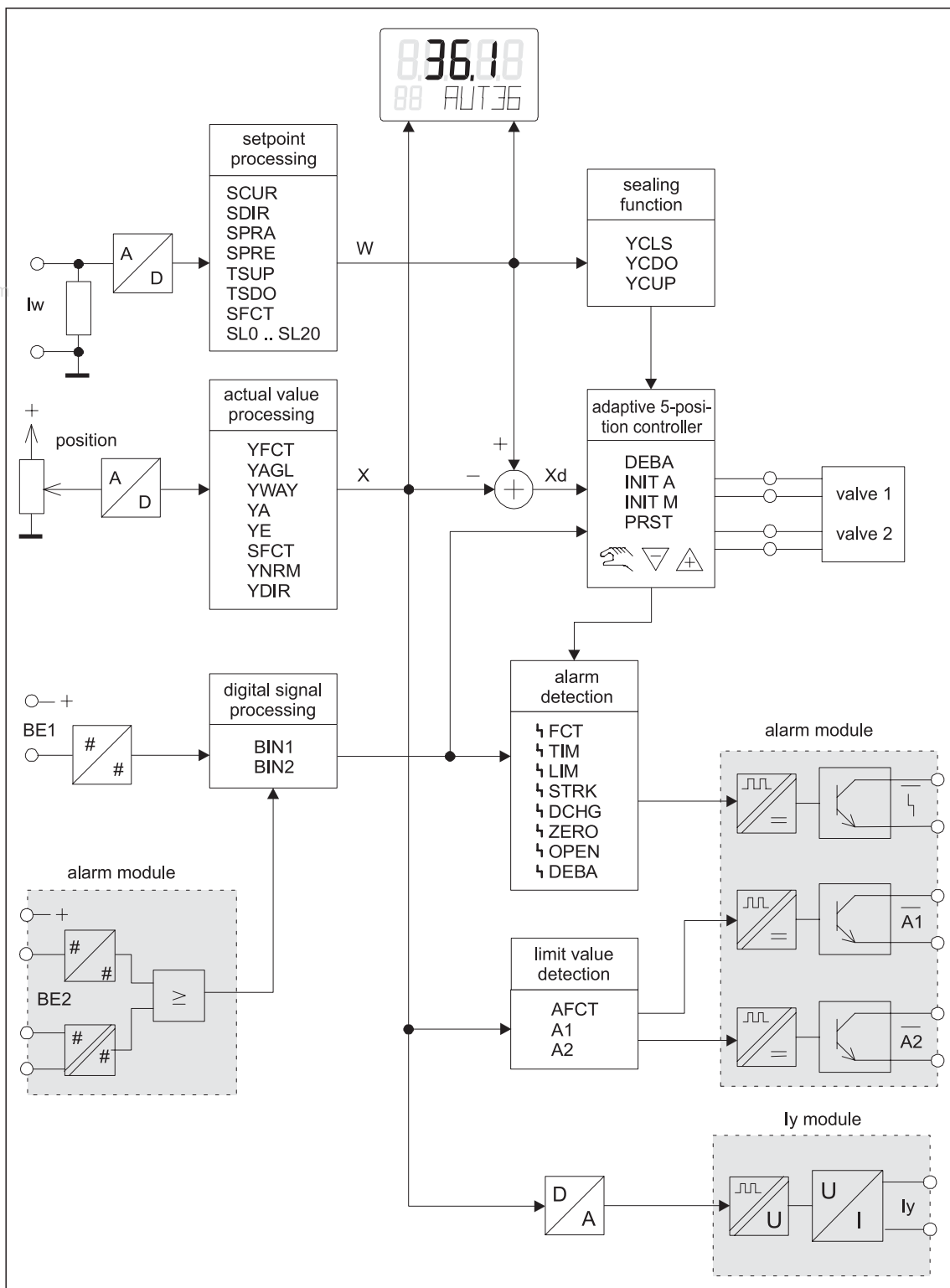

Figure 4-7 Configuration block diagram

Normally adjustment of the first three following parameters is completely sufficient to enable a positioner to be operated by an actuator. If you wish to become familiar with all details of the positioner, try out incrementally the effects of the remaining parameters by selective trials.



NOTE

In particular if the positioner has previously been operated using a different actuator, it must always be reinitialized in order to restore the factory settings. Only in this way can the positioner matching process start from known conditions. The parameter “55.PRST” is provided for this purpose.

This is also recommended if multiple parameters have been changed in a single session, the effects cannot be assessed and unintended consequences may result.

www.DataSheet4U.com

1.YFCT

Positioning actuator type

This is to match the positioner with the respective actuator and where necessary to the position sensor being used. The following adjustment capabilities are provided:

- YFCT = turn

This adjustment is necessary for the part-turn actuator.

If “turn” is selected, the following parameter “2. YAGL” is automatically set to 90° and cannot be changed.

- YFCT = WAY (Factory setting)

This is necessary for a linear actuator. This allows the positioner to compensate for the non-linearity that arises due to the conversion of the linear movement of the linear actuator into the part-turn movement of the feedback shaft. For this the positioner is factory set so that it shows between “P 49.0 and P 51.0” when the arm on the feedback shaft is vertical to the linear actuator spindle.

- YFCT = LWAY

This must be adjusted, if an external linear potentiometer is to be connected to a linear actuator.

TIP: use this adjustment also for part-turn actuators with reverse direction of control action.

- YFCT = ncSt

Use this when an NCS is fitted to a part-turn actuator.

- YFCT = -ncSt

This must be set when an NCS is used with a part-turn actuator with reverse direction of control action.

- YFCT = ncSL

This must be set when an NCS is used with a linear actuator.

- YFCT = ncSLL

This must be adjusted if an NCS is to be connected to a linear actuator with the position converted by an arm into a part-turn movement.



NOTE

After “LWAY, ncSt, -ncSt or ncSL” have been adjusted, the parameter “3. YWAY” will not be displayed.

2.YAGL

Rated angle of rotation of the feedback shaft

In part-turn actuators, an angle of 90° is preset automatically by 1.YFCT = turn (see above). In linear actuators (1.YFCT = WAY) a value of 33° or 90° can be selected depending on the stroke range:

- 33° for strokes ≤ 20 mm
- 90° for strokes > 20 mm

When using the lever up to 35 mm, both angles of rotation (33° and 90°) are possible.

The long lever (> 35 mm stroke) is only designed for an angle of rotation setting of 90°. It is not part of the mounting kit set 6DR4004-8V but must be ordered separately under order number 6DR4004-8L.



NOTE

The setting of the transmission ratio selector on the positioner (see figure 2-2, page 17 and figure 2-3, page 18) **must** correspond to the angle value selected under “2.YAGL”.

3.YWAY

Lever arm transmission

Selection of the lever arm range: serves to display the real stroke after initialization. The use of this parameter is optional. You only need to set this parameter if you want to have the way in mm displayed at the end of the initialization.

If the parameter value “oFF” is selected here, the real stroke is not displayed after initialization.



NOTE

The specification “YWAY” must match the mechanical lever arm transmission. The carrier must be set to the value of the actuator stroke, if this is not scaled to the next highest scaled value.

4.INITA

Automatic initialization (see chapter 3.6, page 72)

By selecting “Strt” and pressing the increment key  for at least 5 seconds, automatic initialization is started. The initialization process is displayed by “RUN 1” to “RUN 5” (see figure 3-35, page 83 to figure 3-38, page 86).

5.INITM

Manual initialization

By selecting “Strt” and pressing the increment key  for at least 5 seconds, manual initialization is started. The manual initialization process is described in chapter 3.6.3, page 76 and chapter 3.6.6, page 81.

www.DataSheet4U.com



NOTE

If the positioner has already been initialized, for INITA and INITM it is possible to transfer it to its non-initialized state without changing the remaining parameters by pressing the decrement key  for 5 s.

6.SCUR

Current range of the setpoint

The selection of the current range depends on the connection type. “0mA” (0 to 20 mA) is only possible in three-/four-wire connections (see figure 3-23, page 64).

7.SDIR

Setpoint direction (see figure 4-8, page 101)

The setting of the setpoint direction serves to reverse the direction of action of the setpoint. It is used mainly for the split range mode and in single-acting actuators with the safety position “up”.

8.SPRA

Split range start (see figure 4-8)
and

9.SPRE

Split range end (see figure 4-8)

The parameters “8.SPRA” and “9.SPRE” in connection with the parameter “7.SDIR” serve to restrict the active setpoint range. In this way split range tasks can be solved with the following characteristics.

- rising / falling
- falling / rising
- falling / falling
- rising / rising

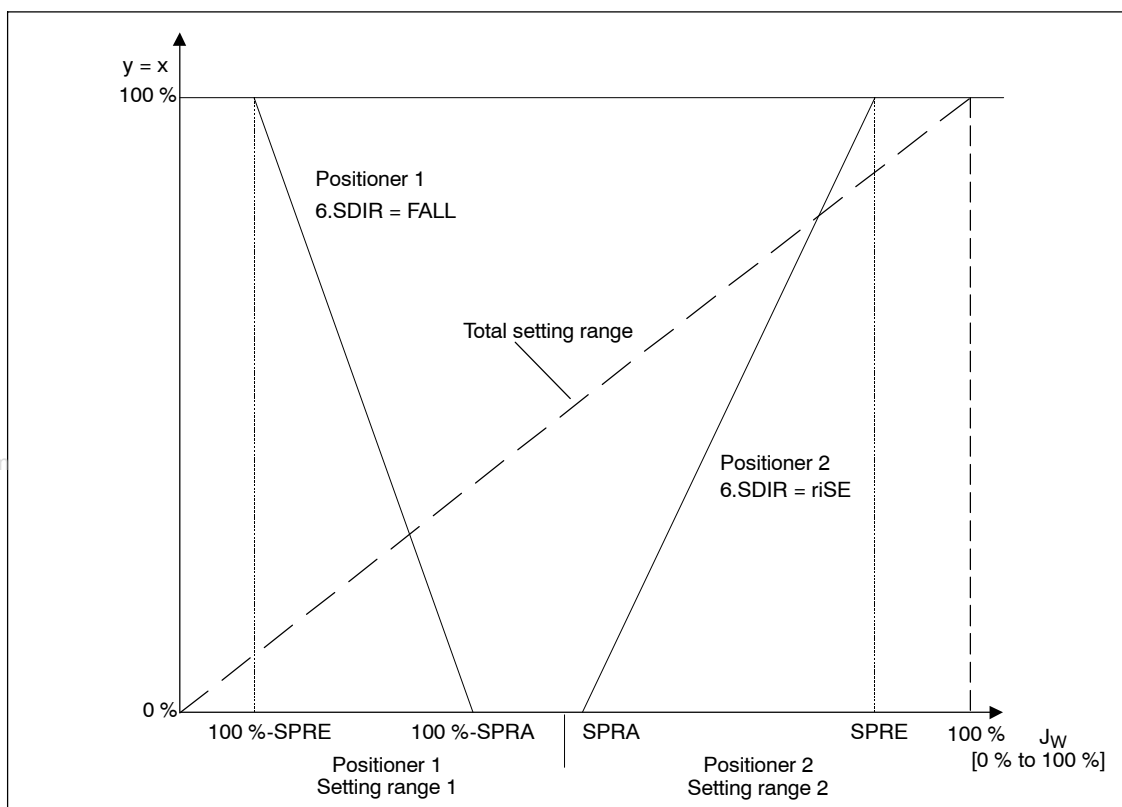

Figure 4-8 Example: Split range-operation with two positioners

- 10.TSUP** Setpoint ramp UP
and
11.TSDO Setpoint ramp DOWN

The setpoint ramp is effective in automatic operation and limits the speed of alteration of the active setpoint. When switching over from manual operation to automatic the active setpoint is adjusted to the setpoint on the positioner with the setpoint ramp.

This bumpless manual/automatic switchover avoids excessive pressure increases on long pipelines.

In the position TSUP = Auto the slower of the two travel times determined during initialization is used for the setpoint ramp. TSDO is then ineffective.

- 12.SFCT** Setpoint function (see figure 4-9, page 102)

Non-linear valve characteristics can be linearized with this function and any flow characteristics simulated in linear valve characteristics.

Six valve characteristics are stored in the positioner

- linear (12.SFCT = Lin, factory setting)
- equal percentage 1 : 25 (12.SFCT = 1:25)
- equal percentage 1 : 33 (12.SFCT = 1:33)
- equal percentage 1 : 50 (12.SFCT = 1:50)
- inverse equal percentage 25 : 1 (12.SFCT = n1:25)
- inverse equal percentage 33 : 1 (12.SFCT = n1:33)
- inverse equal percentage 50 : 1 (12.SFCT = n1:50)
- freely adjustable (12.SFCT = FrEE)

13.SL0 to 33.SL20 Setpoint turning points

A flow parameter can be assigned to the respective setpoint turning value at an interval of 5 %. These points lead to a polygon chain with 20 straight lines which therefore represents a projection of the valve characteristic.

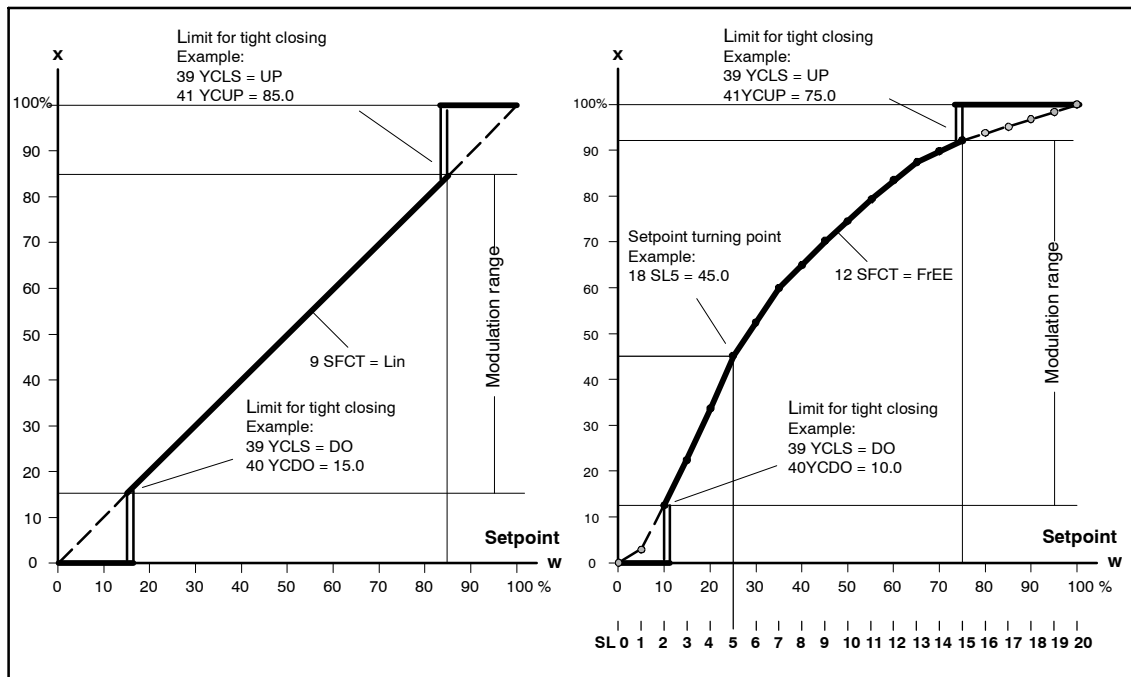

Figure 4-9 Setpoint characteristic, manipulated variable standardization and tight closing function

The setpoint vertex values can only be input at 12.SFCT=FrEE. You may only enter a strictly monotonous characteristic, and two consecutive vertex values must differ by at least 0.2 %.

34.DEBA

Dead zone of the controller

At $dEbA = AU$ the dead zone in automatic operation is adapted continuously to the requirements of the control circuit. The dead zone is gradually increased on detecting a control oscillation. The reverse adaptation takes place by a time criterion.

In the other discrete settings the fixed value is used for the dead zone.

35.YA

Manipulated variable limiting start (see figure 4-9 and 4-10)
and

36.YE

Manipulated variable limiting end (see figure 4-9 and 4-10)

With the parameters "YA" and "YE" the mechanical actuating distance (from stop to stop) is limited to the set values. In this way the mechanical setting range of the actuator can be limited to the active flow and the integral saturation of the commanding controller avoided.

www.DataSheet4U.com

**NOTE**

YE must always be set to greater than YA.

37.YNRM

Manipulated variable standardization (see figure 4-9 and 4-10)

With limiting of the manipulated variable (by "35.YA" and "36.YE") two different scalings are produced for the display and the position feedback via the current output (MPOS or FLOW).

The MPOS scaling shows the mechanical position (0 to 100%) between the hard stops of the initialization. This is not affected by the parameters "35.YA" and "36.YE". The parameters "35.YA" and "36.YE" are displayed in the MPOS-scale.

The FLOW-scale is the standardization (0 to 100%) to the range between "35.YA" and "36.YE". The setpoint w (0 to 100%) is always referred to this range. This gives (also by using valve characteristics) a quasi-flow-proportional display and position feedback I_y .

To calculate the control difference, the setpoint is also shown in the appropriate scale on the display.

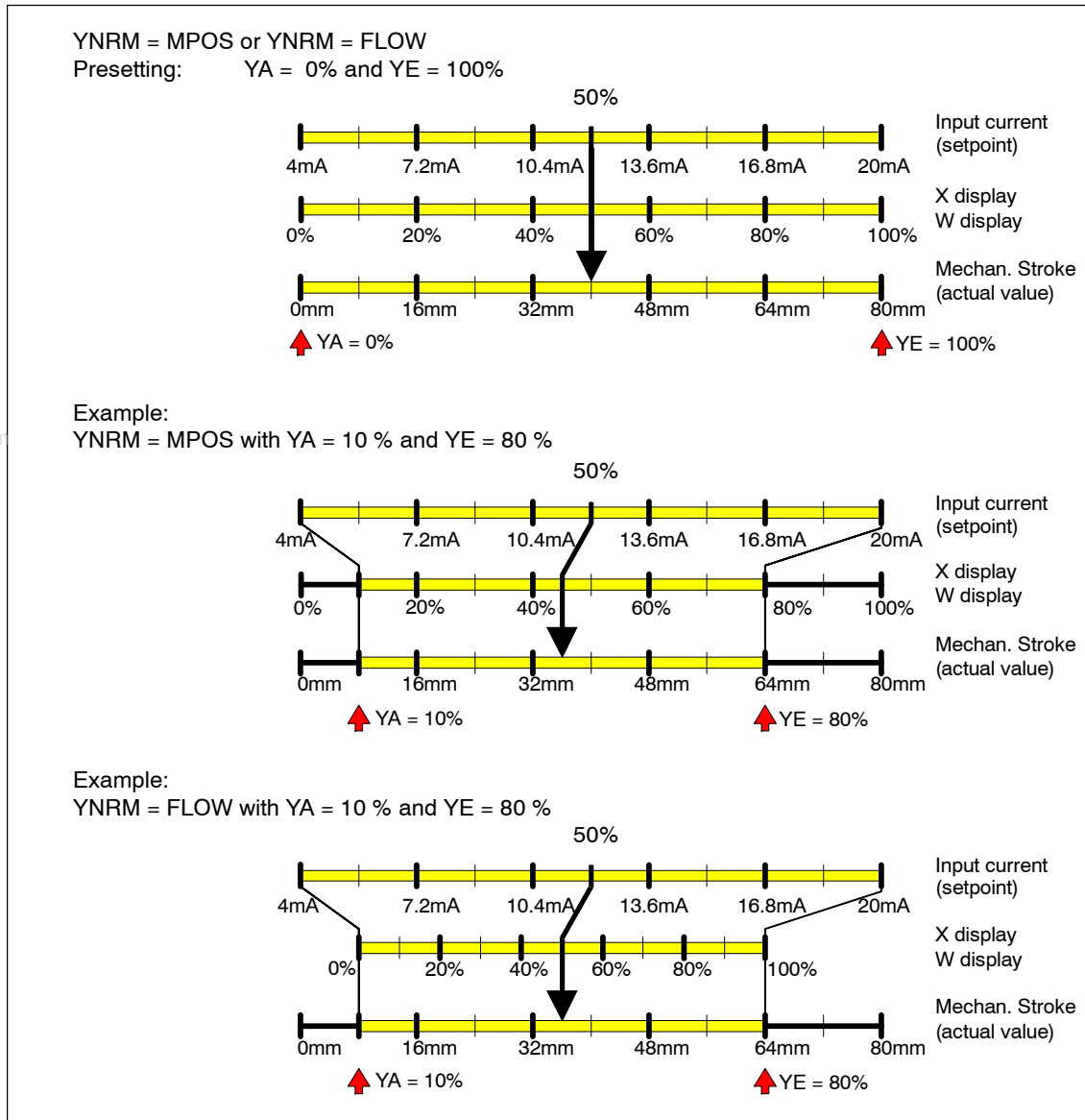

Figure 4-10 Dependence on the stroke of standardization and on YA and YE in the example of an 80 mm linear actuator

38.YDIR

Manipulated variable direction of action

The direction of action (rising or falling) of the display and the position feedback (ly) can be set with this.

39.YCLS

Tight closing with manipulated variable (see figure 4-9, page 102)

With this function the valve can be driven to the seat with the maximum actuating force of the actuator (continuous contact of the piezo-valves). The tight closing function can be activated on one side or for both limit positions. YCLS becomes active when the setpoint is below the value set with parameter "YCDO" or above that set with parameter "YCUP".

**NOTE**

If the control function to close tightly is activated, for parameter “49. LIM” the monitoring of the control deviation in each overrun direction (YCDO: < 0 %, YCUP: > 100 %) is disabled. This function is particularly useful for valves with a soft seating. For long term monitoring of the end-stop positions, we recommend activating the parameters “52. ZERO” and “53. OPEN”.

40.YCDO

Value for tight closing, bottom
and

41.YCUP

Value for tight closing, top

**NOTE**

“40.YCDO” must always be set to less than “41.YCUP”. The tight closing function has a fixed hysteresis of 1 %. “40.YCDO” and “41.YCUP” relate to mechanical stops and are independent of the settings of “7.SDIR” and “38.YDIR”.

42.BIN1

Function digital input 1 (see figure 4-6, page 96)
and

43.BIN2

Function digital input 2 (see figure 4-6)

The parameters “BIN1” and “BIN2” can be set individually depending on the purpose. The direction of action can be adapted to an NCC or an NOC.

- BIN1 or BIN2 = on or -on

Digital messages of the periphery (e.g. pressure or temperature switches) can be read out via the HART interface or lead to responding of the fault message output by OR linking with other messages.

- BIN1 = bLoc1

The Configuration operating mode is locked to prevent it being adjusted (e.g. by a wire jumper between terminals 9 and 10).

- BIN1 = bLoc2

If digital input 1 has been activated, manual operation is also locked in addition to the Configuration operating mode.

- BIN1 or BIN2 = uP or doWn (contact closes) or -uP or -doWn (contact opens).

The actuator drives the linear actuator to the upper or lower stop when the digital input is activated with continuous contact.

- BIN1 or BIN2 (contact closes) = StoP or -StoP (contact opens).

With activated digital input the piezo-valves are blocked and the actuator remains in the last position. Leakage messages can then be executed without initialization function.

- BIN1 oder BIN2 = PSt oder -PSt

Depending on settings, a partial stroke test can be initiated via binary input 1 or 2 by actuating an opener or closer.

- BIN1 or BIN2 = oFF (factory setting)

no function

special function of DI1: If the digital input 1 is activated in P manual operation by a jumper between terminals 9 and 10, , when the operating mode key is pressed the firmware version will be displayed. line of the display.

If one of the above named functions is selected with the parameters "BIN1" and "BIN2" simultaneously, then "Blocking" has priority over "Up" and "Up" priority over "Down".

www.DataSheet4U.com

44.AFCT

Alarm function

The actuator can report the exceeding (max.) or dropping below (min) of a specified stroke or angle of rotation. The response of the alarms (limit values) is related to the MPOS-scaling (see figure 4-10, page 104). The alarms are reported by the alarm module (order no. 6DR4004-6A or -8A). In addition the alarms can be read out through the HART interface (optional).

The direction of action of the digital outputs can be adapted from high active to low active sequence systems.

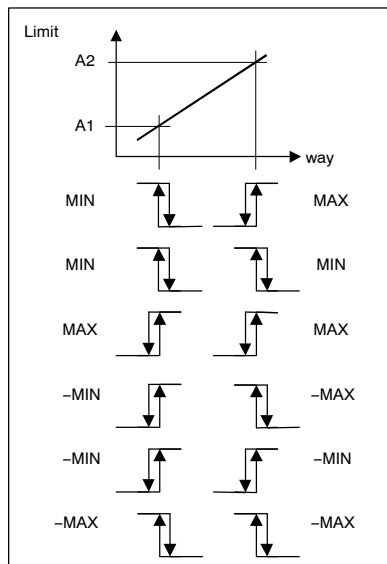

		Alarm module	
		A1	A2
A1 = 48		AFCT = MIN / MAX	
A2 = 52			
Travel = 45		Activated	
Travel = 50			
Travel = 55			Activated

		Alarm module	
		A1	A2
A1 = 48		AFCT = -MIN / -MAX	
A2 = 52			
Travel = 45			Activated
Travel = 50		Activated	Activated
Travel = 55		Activated	

		Alarm module	
		A1	A2
A1 = 52		AFCT = MIN / MAX	
A2 = 48			
Travel = 45		Activated	
Travel = 50		Activated	Activated
Travel = 55			Activated

		Alarm module	
		A1	A2
A1 = 52		AFCT = -MIN / -MAX	
A2 = 48			
Travel = 45			Activated
Travel = 50		Activated	
Travel = 55		Activated	

**NOTE**

If you have activated the extended diagnostics (parameter 51.XDIAG) with On2 or On3, the alarms cannot be output via the alarm unit. However, the message is possible via HART communication at any time.

45.A1

Response threshold alarm 1
and

46.A2

Response threshold alarm 2

The alarm thresholds are related to the mechanical path (MPOS-scale).

47. 1 FCT

Function of the fault message output

The fault message output serves as a group message for following faults:

- Control error (e.g. by actuator fault, valve fault, compressed air failure) with the parameters "48.1TIM" and "49.1LIM"
- Positioner not in automatic mode
- Digital input activated (see parameter "42.BIN1" and "43.BIN2")
- Exceeding of a limit value (e.g. way integral or valve seat, see parameter 50 to 54)

It also responds at:

- Power failure
- Processor fault

The direction of action of the digital outputs can be adapted from high active to low active sequence systems.

For more information on error messages, see chapter 4.5.3 Online-Diagnostics, page 131.

48.4 TIM

Monitoring time for setting the fault messages

The set value(s) is/are for the specification of the time, within which the positioner must have reached a compensated state. The corresponding response threshold is preset with "49.4 LIM".

If the set time is exceeded, the fault message output is set.



NOTE

If the tight closing function is activated, for parameter "49.4 LIM", the monitoring of the control deviation in each overrun direction (YCDO: < 0 %, YCUP: > 100 %) is deactivated. This function is particularly useful for valves with a soft seat. For the long-term monitoring of the endstop positions, we recommend activating the parameters "F.4 ZERO" and "G.4 OPEN".

You can find more information on fault messages in chapter 4.5.3 Online Diagnostics.

49.4 LIM

Response threshold for fault messages

A value (%) can be set here for the permissible control deviation for triggering the fault message.

If parameters 48 and 49 are set to "Auto" (factory setting), the fault message is set if the short step zone is not reached within a certain time. Within 5 to 95 % of the actuator travel, this time is 10 to 90 % of 10 times the initialization actuating time.

50.PRST

Preset

Establishes the factory setting and resets the initialization.



NOTE

After "Preset" the positioner needs to be re-initialized. All previously determined maintenance parameters are deleted.

51.XDIAG

Activation of the extended diagnostics

The extended diagnostics is deactivated at the factory, parameter 51 is therefore at "OFF". There are three operating modes for activating the extended diagnostics:

- On1: The extended diagnostics is activated and the threshold 3 error messages are also output via the fault message output.
- On2: The extended diagnostics is activated, the threshold 2 error messages are output via alarm output 2 and the threshold 3 error messages are also output via fault message output.
- On3: The extended diagnostics is activated, the threshold 1 error messages are output via alarm output 1, the threshold 2 error messages are output via alarm output 2 and the threshold 3 error messages are also output via the fault message output.

www.DataSheet4U.com

**NOTE**

Please note that the menu items of the extended diagnostics from A. P_{ST} to P.4 P_{AVG} are only displayed in the display after selecting one of the three On operating modes.

With the factory setting, the parameters of menu items A to P are deactivated by default (OFF). The corresponding parameters are only displayed once you have activated the relevant menu item with "On".

A.4PST	<p>Partial stroke test</p> <p>This parameter activates the partial stroke test for the cyclic or manual partial stroke test of Up/Down and modulating valves.</p> <p>The partial stroke test can be triggered via keyboard, a binary input or the HART communication.</p>
A1.STPOS	<p>Start position</p> <p>The start position of the partial stroke test is specified here within the range of 0.0 to 100.0%.</p>
A2.STTOL	<p>Start tolerance</p> <p>The start tolerance in relation to the start position is specified here in the range of 0.1 to 10.0%. That means, with a start position of e.g. 50% and a start tolerance of 2%, a partial stroke test can only be triggered during operation if the current position is between 48 and 52%.</p>
A3.STEP	<p>Step height</p> <p>Input of the step height of the partial stroke test within the range of 0.1 to 100.0%. The factory setting is 10.0%.</p>
A4.STEPD	<p>Step direction</p> <p>Input of the step direction of the partial stroke test. The following options are available: “up”, “do” (down), “up do” (up and down). If “up” is selected, the actuator is moved in a controlled manner from its start position to the target position (start position + step height) and then back to the original position in a controlled way once the target position has been reached. The procedure for the “do” option is the same but in the opposite direction. With “up do”, the actuator first travels in a controlled manner from its start position to the upper target position (start position + step height), then controlled from the upper to the lower target position (start position – step height). After reaching the lower target position, it returns to its original position in a controlled manner.</p>
A5.INTRV	<p>Test interval</p> <p>Input of the interval for the cyclic partial stroke test within the range of one day to 365 days.</p>

A6.PSTIN

Partial stroke test reference step time
(PSTIN = Partial Stroke Test Initialization)

Measurement of the reference step time for the partial stroke test. After the initialization of the device, the calculated (C = calculated) average actuating time of the control valve is displayed in seconds in the form: C ###.#. This time can be used as reference step time, however it is only a rough guide value.

That is why it is recommended to measure the reference step time here after the specification of the partial stroke test (parameters A1 to A5) by pressing the Greater Than button for five seconds. In doing so, "rEAL" is shown in the display. The device then automatically moves to the set start position, performs the desired step and saves the time required to do this. The time that is measured is the controlled movement from start position to target position. After the successful measurement, this reference step time is shown in the display in the form: "###.#" seconds.

If a reference step is attempted without previous initialization of the device, "noini" appears in the display. If the start position cannot be approached or if the jump destination cannot be reached, "Fdini" (Failed PST Initialization) is displayed.

A7.FACT1

Factor 1

Input of the factor for the threshold 1 error message. The factor 1 refers to the reference step time. If a specified partial stroke test results e.g. in a reference step time of 1.0 second and factor 1 is used in the factory setting of 1.5, the threshold 1 error message of the partial stroke test is performed for a measuring time of 1.5 seconds.

A8.FACT2

Factor 2

Input of the factor for the threshold 2 error message. The factor 2 refers to the reference step time. If a specified partial stroke test results e.g. in a reference step time of 1.0 second and factor 2 is used in the factory setting of 3.0, the threshold 2 error message of the partial stroke test is performed for a measuring time of 3.0 seconds.

A9.FACT3

Factor 3

Input of the factor for the threshold 3 error message. The factor 3 refers to the reference step time. If a specified partial stroke test results e.g. in a reference step time of 1.0 second and factor 3 is used in the factory setting of 5.0, the threshold 3 error message of the partial stroke test is performed for a measuring time of 5.0 seconds. At the same time, if this time threshold is exceeded, the excitation signal of the actuator is cancelled to prevent any sudden breaking free and overshooting of a valve that might be jammed or rusted in place.

The partial stroke test is thus stopped immediately, a threshold 3 error is reported and the actuator is moved back to its original position.

b.4.DEVI

General control valve malfunction

This parameter activates the dynamic monitoring of the control valve reaction. To do this, the actual position sequence is compared to the guide value and the expected position sequence, which allows conclusions with regard to the correct operational behavior of the control valve.

When the parameter is activated, the submenu for the general control valve malfunctions from b1 to b5 opens. The function can be configured there.

b1.TIM

Time constant of the low-pass filter

The time constant of the low-pass filter is determined during the automatic initialization of the device. In the factory setting, parameter b1 therefore indicates "Auto".

If the user is very familiar with the process sequence or desires a certain filter time constant for application-specific reasons, parameter b1 can be set from one second to 400 seconds manually. One second causes no damping, 400 seconds result in a strong damping effect.

b2.LIMIT

Limit for the general control valve malfunction

Sets the limit for the deviation from the model behavior. This limit is a reference value for the error message factors. Factory setting is 1.0 %.

b3.FACT1

Factor 1

Input of the factor for the threshold 1 error message. This factor refers to the limit for the general control valve malfunction. Factory setting for factor 1 is 5.0. That means, for b2.LIMIT = 1.0% and factor 1 = 5.0, the first error message is triggered at a control deviation of 5.0 % from the model behavior.

b4.FACT2

Factor 2

Input of the factor for the threshold 2 error message. This factor refers to the limit for the general control valve malfunction. Factory setting for factor 2 is 10.0. That means, for b2.LIMIT = 1.0% and factor 2 = 10.0, the second error message is triggered at a control deviation of 10.0 % from the model behavior.

b5.FACT3

Factor 3

Input of the factor for the threshold 3 error message. This factor refers to the limit for the general control valve malfunction. Factory setting for factor 3 is 15.0. That means, for b2.LIMIT = 1.0% and factor 3 = 15.0, the third error message is triggered at a control deviation of 15 % from the model behavior.

C.4.LEAK	<p>Pneumatic leakage</p> <p>This parameter is used to activate the function for the detection of a pneumatic leakage. To do so, the changes of position and the internally used controller output are recorded and filtered, depending on the direction. The filter result provides a coefficient that allows the detection of any leakage.</p> <p>Note that the detection of a leak can only be provided clear results for spring-loaded actuators.</p>
C1.LIMIT	<p>Limit for the leakage indicator</p> <p>Sets the limit for the leakage indicator. The leakage indicator is scaled within the range of 0.0 to 100.0. Factory setting for the limit is 30.0. In other words, there is leakage below this limit. A leak can be expected if this value is exceeded.</p> <p>To be able to make full use of the sensitivity of the detection process, it is recommended to perform a ramp test with a calibrator after the automatic initialization of the device. The ramp should cover the standard operating range of the valve and correspond in steepness to the approximate dynamic requirements of the application. During the ramp test, parameter 15.ONLK of the diagnostics menu provides information on the values shown by the leakage indicator. This allows the limit for the leakage coefficient to be defined above the maximum ramp test value.</p>
C2.FACT1	<p>Factor 1</p> <p>Input of the factor for the threshold 1 error message. This factor refers to the limit for the leakage indicator. Factory setting for factor 1 is 1.0. That means, for C1.LIMIT = 30.0 and factor 1 = 1.0, the first leakage error message is triggered at a leakage indication of 30.0.</p>
C3.FACT2	<p>Factor 2</p> <p>Input of the factor for the threshold 2 error message. This factor refers to the limit for the leakage indicator. Factory setting for factor 2 is 1.5. That means, for C1.LIMIT = 30.0 and factor 2 = 1.5, the second leakage error message is triggered at a leakage indication of 45.0.</p>
C4.FACT3	<p>Factor 3</p> <p>Input of the factor for the threshold 3 error message. This factor refers to the limit for the leakage indicator. Factory setting for factor 3 is 2.0. That means, for C1.LIMIT = 30.0 and factor 3 = 2.0, the third leakage error message is triggered at a leakage indication of 60.0.</p>

d.STIC

Slipstick effect

This parameter is used to activate the function for the detection of a slipstick effect. The device tries to detect sudden changes of the valve position that indicate excess slipstick. If the device detects a slipstick, the filtered step is saved as slipstick value. When the valve moves normally again (without detection of a slipstick), the slipstick value is reduced slowly.

Note that to avoid misinterpretations, for actuators with actuating times below 1 s, the positioner cannot distinguish reliably between a normal movement and a sudden change.

d1.LIMIT

Limit for the slipstick detection

Sets the limit for a step caused by a slipstick effect. The limit can be set within the range of 0.0 to 100.0%. Factory setting for the limit is 1.0.

d2.FACT1

Factor 1

Input of the factor for the threshold 1 error message. This factor refers to the limit for the slipstick detection. Factory setting for factor 1 is 2.0. That means, for d1.LIMIT = 1.0 and factor 1 = 2.0, the first slipstick error message is triggered when the current slipstick value has reached 2.0.

d3.FACT2

Factor 2

Input of the factor for the threshold 2 error message. This factor refers to the limit for the slipstick detection. Factory setting for factor 2 is 5.0. That means, for d1.LIMIT = 1.0 and factor 2 = 5.0, the second slipstick error message is triggered when the current slipstick value has reached 5.0.

d4.FACT3

Factor 3

Input of the factor for the threshold 3 error message. This factor refers to the limit for the slipstick detection. Factory setting for factor 3 is 10.0. That means, for d1.LIMIT = 1.0 and factor 3 = 10.0, the third slipstick error message is triggered when the current slipstick value has reached 10.0.

E.4.DEBA	<p>Dead zone monitoring</p> <p>This parameter activates the monitoring of the dead zone adaptation. Prerequisite for the function is the setting of parameter "34.DEBA" = Auto.</p>
E1.LEVL3	<p>Threshold for the monitoring of the dead zone adaptation.</p> <p>This value (%) can be used for the automatic adaptation of the dead zone. If the dead zone exceeds the set value, the threshold 3 error message is triggered. The three-level error message is not implemented for dead zone monitoring.</p>
F.4.ZERO	<p>Zero point offset</p> <p>This function is for detecting when the lower stop has changed its value compared to the value during initialization by more than the set thresholds. Monitoring is only possible if the valve is within the tight closing function. The activation of the "bottom tight closing function" (parameter "39.YCLS") is therefore prerequisite.</p>
F1.LEVL1	<p>Threshold 1</p> <p>First threshold for monitoring the lower limit stop. If the set absolute value is exceeded during "bottom tight closing", this will trigger the threshold 1 error message.</p>
F2.LEVL2	<p>Threshold 2</p> <p>Second threshold for monitoring the lower limit stop. If the set absolute value is exceeded during "bottom tight closing", this will trigger the threshold 2 error message.</p>
F3.LEVL3	<p>Threshold 3</p> <p>Third threshold for monitoring the lower limit stop. If the set absolute value is exceeded during "bottom tight closing", this will trigger the threshold 3 error message.</p>

G.4 OPEN

Shifting the upper stop

This function is for detecting when the upper stop has changed its value compared to the value during initialization by more than the specified tolerance value. Monitoring is only possible if the valve is within the tight closing function. The activation of the “top tight closing function” (parameter “39.YCLS”) is therefore prerequisite.

G1.LEVL1

Threshold 1

First threshold for monitoring the upper limit stop. If the set absolute value is exceeded during “top tight closing”, this will trigger the threshold 1 error message.

www.DataSheet4U.com

G2.LEVL2

Threshold 2

Second threshold for monitoring the upper limit stop. If the set absolute value is exceeded during “top tight closing”, this will trigger the threshold 2 error message.

G3.LEVL3

Threshold 3

Third threshold for monitoring the upper limit stop. If the set absolute value is exceeded during “top tight closing”, this will trigger the threshold 3 error message.



NOTE

Monitoring of the lower and upper limit stops does not only react to valve faults. A misadjustment of the position feedback is also detected as a malfunction if the threshold values are exceeded.

H.4.TMIN	<p>Monitoring of the lower temperature limit</p> <p>The current temperature in the positioner housing is measured by a sensor on the electronic circuit board. This parameter is for the three-level monitoring of the lower temperature limit.</p>
H1.TUNIT	<p>Temperature unit</p> <p>The temperature unit can be switched over by pressing the Greater Than or Smaller Than button between °C and °F. Another way of switching over is the J1.TUNIT parameter for monitoring the upper temperature limit. The selected unit applies to all temperature-related parameters.</p>
H2.LEVL1	<p>Threshold 1</p> <p>First threshold for monitoring the lower temperature limit. The factory setting is -25.0 °C. If the temperature falls below the set value, the threshold 1 error message is triggered.</p>
H3.LEVL2	<p>Threshold 2</p> <p>Second threshold for monitoring the lower temperature limit. The factory setting is -30.0°C. If the temperature falls below the set value, the threshold 2 error message is triggered.</p>
H4.LEVL3	<p>Threshold 3</p> <p>Third threshold for monitoring the lower temperature limit. The factory setting is -40.0°C. If the temperature falls below the set value, the threshold 3 error message is triggered.</p>

J.4.TMAX

Monitoring of the upper temperature limit

The current temperature in the positioner housing is measured by a sensor on the electronic circuit board. This parameter is for the three-level monitoring of the upper temperature limit.

J1.TUNIT

Temperature unit

The temperature unit can be switched over by pressing the Greater Than or Smaller Than button between °C and °F. Another way of switching over is the H1.TUNIT parameter for monitoring the lower temperature limit. The selected unit applies to all temperature-related parameters.

www.DataSheet4U.com

J2.LEVL1

Threshold 1

First threshold for monitoring the upper temperature limit. The factory setting is 75.0°C. If the temperature exceeds the set value, the threshold 1 error message is triggered.

J3.LEVL2

Threshold 2

Second threshold for monitoring the upper temperature limit. The factory setting is 80.0°C. If the temperature exceeds the set value, the threshold 2 error message is triggered.

J4.LEVL3

Threshold 3

Third threshold for monitoring the upper temperature limit. The factory setting is 90.0°C. If the temperature exceeds the set value, the threshold 3 error message is triggered.

L4.STRK	<p>Monitoring of the displacement integral</p> <p>This parameter activates the monitoring of the displacement integral. This function allows the preventive maintenance of the control valve, also see chapter 4.5 "Diagnostics", page 122.</p>
L1.LIMIT	<p>Limit for the number of strokes</p> <p>Input of the limit for the number of strokes. The parameter can be used depending on the requirement profile of the user.</p> <p>On the one hand, it is possible to enter a maximal number for the strokes and to use factors smaller than one to receive warning messages when a certain fraction of the maximal number is reached. On the other hand, a minimum value can be entered for the strokes. Factors greater than one are then used to receive warning messages for certain limits above the minimum value. Factory setting for the limit is 1 000 000.</p>
L2.FACT1	<p>Factor 1</p> <p>Input of the factor for the threshold 1 error message. This factor refers to the limit for the number of strokes. Factory setting for factor 1 is 1.0. That means, for L1.LIMIT = 1 000 000 and factor 1 = 1.0, the first stroke counter error message is triggered after 1 000 000 strokes.</p>
L3.FACT2	<p>Factor 2</p> <p>Input of the factor for the threshold 2 error message. This factor refers to the limit for the number of strokes. Factory setting for factor 2 is 2.0. That means, for L1.LIMIT = 1 000 000 and factor 2 = 2.0, the second stroke counter error message is triggered after 2 000 000 strokes.</p>
L4.FACT3	<p>Factor 3</p> <p>Input of the factor for the threshold 3 error message. This factor refers to the limit for the number of strokes. Factory setting for factor 3 is 5.0. That means, for L1.LIMIT = 1 000 000 and factor 3 = 5.0, the third stroke counter error message is triggered after 5 000 000 strokes.</p>

O.4 DCHG

Monitoring of the changes of direction

This parameter activates the monitoring of the changes of direction. This function allows the preventive maintenance of the control valve, also see chapter 4.5 "Diagnostics", page 122.

O1.LIMIT

Limit for the changes of direction

Input of the limit for the number of changes of direction.

On the one hand, it is possible to enter a maximal number for the changes of direction and to use factors smaller than one to receive warning messages when a certain fraction of the maximal number is reached. On the other hand, a minimum value can be entered for the changes of direction. Factors greater than one are then used to receive warning messages for certain limits above the minimum value. Factory setting for the limit is 1 000 000.

www.DataSheet4U.com

O2.FACT1

Factor 1

Input of the factor for the threshold 1 error message. This factor refers to the limit for the number of changes of direction. Factory setting for factor 1 is 1.0. That means, for O1.LIMIT = 1 000 000 and factor 1 = 1.0, the first direction change error message is triggered after 1 000 000 strokes.

O3.FACT2

Factor 2

Input of the factor for the threshold 2 error message. This factor refers to the limit for the number of changes of direction. Factory setting for factor 2 is 2.0. That means, for O1.LIMIT = 1 000 000 and factor 2 = 2.0, the second direction change error message is triggered after 2 000 000 strokes.

O4.FACT3

Factor 3

Input of the factor for the threshold 3 error message. This factor refers to the limit for the number of changes of direction. Factory setting for factor 3 is 5.0. That means, for L1.LIMIT = 1 000 000 and factor 3 = 5.0, the third direction change error message is triggered after 5 000 000 strokes.

P.4PAVG

Calculation of the position average

This parameter is used to activate the function for the calculation of the position average. The function allows the calculation of a reference average for the position sequence within preset intervals and the calculation of comparison average values for the following intervals. If the comparison average values deviate from the reference average, error messages are displayed, depending on the set thresholds.

P1.TBASE Time basis for the formation of the average value

Sets the intervals for the formation of the average value. The following time intervals are available:

- 30 minutes
- 8 hours
- 5 days
- 60 days
- 2.5 years

P2.STATE Status of the calculation of the position average

After activating the function with parameter P.4PAVG, the initial status of the calculation of the position average is "IdLE" (inactive). To start the calculation of the position average, the Greater Than button is pressed for five seconds. The display text then switches from "IdLE" to "rEF" (reference average is calculated) and remains there until the selected time interval has passed. The reference average is then shown on the display.



NOTE

The current comparison average is displayed in the diagnosis menu under parameter 19.PAVG as soon as the first comparison interval has passed. During the first comparison interval, "COMP" (comparison interval) is displayed there.

P3.LEVL1 Threshold 1

First threshold for monitoring the reference average. The factory setting is 2.0%. If a comparison average deviates from the reference by more than this value, the threshold 1 error message is triggered.

P4.LEVL2 Threshold 2

Second threshold for monitoring the reference average. The factory setting is 5.0%. If a comparison average deviates from the reference by more than this value, the threshold 2 error message is triggered.

P5.LEVL3 Threshold 3

Third threshold for monitoring the reference average. The factory setting is 10.0%. If a comparison average deviates from the reference by more than this value, the threshold 3 error message is triggered.



4.5 Diagnosis

4.5.1 Diagnostic display

To access the diagnostic display in automatic or manual mode, press all three buttons for at least two seconds.

This following table gives an overview of the values that can be displayed. The third column contains the term from which the abbreviation is derived, unless it is self-explaining.

The structure of the diagnostic display is similar to that in "Configuration" mode: the upper line shows the diagnosis value, the lower line shows the number and abbreviation of the displayed value.

Use the operating mode button  to select the next diagnosis value. By pressing and holding the operating mode button and simultaneously pressing the decrement button  the diagnosis values can be selected in reverse order.

Certain values can be set to zero by pressing the increment button  for at least 5 seconds. This is noted in the last table column.

Some diagnosis values can be greater than 99999. In this case, the display switches to exponential indication. Example: the value for 1234567 is displayed as 1.23E6.

No.	Abbreviation	Meaning	Values than can be indicated	Unit	Reset possible
1	STRKS	Number of strokes (Strokes)	0 to 4.29E9	–	x
2	CHDIR	Changes of direction (Changes of Direction)	0 to 4.29E9	–	x
3	HCNT	Number of fault messages (HCounter)	0 to 4.29E9	–	x
4	A1CNT	Number of alarms 1 (Alarm 1 Counter)	0 to 4.29E9	–	x
5	A2CNT	Number of alarms 2 (Alarm 2 Counter)	0 to 4.29E9	–	x
6	HOURS	Operating hours (Hours)	0 to 4.29E9	hours	
7	WAY	Determined actuator travel (Way)	0 to 130	mm or °	
8	TUP	Actuating time up (Travel Time Up)	0 to 1000	s	
9	TDOWN	Actuating time down (Travel Time Down)	0 to 1000	s	
10	LEAK	Leakage (Leakage)	P 0.0 to 100.0	%	
11	PST	Monitoring of the Partial Stroke Test	OFF / ###.#, fdini, notSt, SdtSt, fdtSt, notd, Strt	s for ###.#	
12	PRPST	Time since the last Partial Stroke Test	###, notSt, Sdtst, fdtSt	days	
13	NXPST	Time until the next Partial Stroke Test	###, notSt, SdtSt, fdtSt	days	
14	DEVI	General control valve malfunction	Off, 0.0 to 100.0	%	
15	ONLK	Pneumatic leakage	Off, 0.0 to 100.0	–	
16	STIC	Slipstick effect	Off, –100.0 to 100.0	%	
17	ZERO	Zero point offset	Off, –100.0 to 100.0	%	
18	OPEN	Shifting the upper stop	Off, –100.0 to 100.0	%	
19	PAVG	Average position value	0.0 to 100.0	%	
20	P0	Potentiometer value lower stop (0%)	0.0 to 100.0	%	

No.	Abbreviation	Meaning	Values than can be indicated	Unit	Reset possible
21	P100	Potentiometer value upper stop (100%)	0.0 to 100.0	%	
22	IMPUP	Pulse length up (Impulse Length Up)	2 to 160	ms	
23	IMPDN	Pulse length down (Impulse Length Down)	2 to 160	ms	
24	DBUP	Dead zone up (Dead Band Up)	0.1 to 10.0	%	
25	DBDN	Dead zone down (Dead Band Down)	0.1 to 10.0	%	
26	SSUP	Short step zone up (Short Step Zone Up)	0.1 to 100.0	%	
27	SSDN	Short step zone down (Short Step Zone Down)	0.1 to 100.0	%	
28	TEMP	Current temperature	-40 to 85	°C	
29	TMIN	Minimum temperature ("min/max pointer")	-40 to 85	°C	
30	TMAX	Maximum temperature ("min/max pointer")	-40 to 85	°C	
31	T1	Number of operating hours in temperature range 1	0 to 4.29E9	hours	
32	T2	Number of operating hours in temperature range 2	0 to 4.29E9	hours	
33	T3	Number of operating hours in temperature range 3	0 to 4.29E9	hours	
34	T4	Number of operating hours in temperature range 4	0 to 4.29E9	hours	
35	T5	Number of operating hours in temperature range 5	0 to 4.29E9	hours	
36	T6	Number of operating hours in temperature range 6	0 to 4.29E9	hours	
37	T7	Number of operating hours in temperature range 7	0 to 4.29E9	hours	
38	T8	Number of operating hours in temperature range 8	0 to 4.29E9	hours	
39	T9	Number of operating hours in temperature range 9	0 to 4.29E9	hours	
40	VENT1	Number of switching operations pilot valve 1	0 to 4.29E9	-	
41	VENT2	Number of switching operations pilot valve 2	0 to 4.29E9	-	
42	STORE	Save current values as "last maintenance" (press increment button for 5s) (Store)	-	-	
43	PRUP	Prediction up	1 to 40	-	
44	PRDN	Prediction down	1 to 40	-	
45	WT00	Number of operating hours in actuating range WT00	0 to 4.29E9	hours	x
46	WT05	Number of operating hours in actuating range WT05	0 to 4.29E9	hours	x
47	WT10	Number of operating hours in actuating range WT10	0 to 4.29E9	hours	x
48	WT30	Number of operating hours in actuating range WT30	0 to 4.29E9	hours	x
49	WT50	Number of operating hours in actuating range WT50	0 to 4.29E9	hours	x
50	WT70	Number of operating hours in actuating range WT70	0 to 4.29E9	hours	x
51	WT90	Number of operating hours in actuating range WT90	0 to 4.29E9	hours	x
52	WT95	Number of operating hours in actuating range WT95	0 to 4.29E9	hours	x
53	mA	Setpoint current	0.0 to 20.0	mA	

Table 4-1 Overview of diagnosis values

4.5.2 Meaning of the diagnosis values

1 STRKS

Number of strokes



During operation, the actuator movements are added up and can be read off here as the number of strokes. Unit: 100% strokes, i.e. the path between 0 and 100 % and back. The value is written into a non-volatile memory every 15 minutes. It can be set to zero with the increment button .

2 CHDIR

Number of changes of direction

In the controller, every change of direction coming from the dead zone is noted and added to the number of changes of direction.

The value is written into a non-volatile memory every 15 minutes. It can be set to zero with the increment button .

- 3 F CNT** Number of fault messages
- In the controller, every malfunction is noted and added to the number of fault messages. The counter can be set to zero with the increment button .
- 4 A1CNT** Number of alarms 1
and
- 5 A2CNT** Number of alarms 2
- The reaction of alarms 1 and 2 is counted with these two counters. Prerequisite is the activation of the alarms with parameter "44.AFCT". The counters can be set to zero with the increment button .
- 6 HOURS** Operating hours
- The operating hours counter is incremented every hour as soon as the positioner is supplied with electrical power.
- 7 WAY** Determined actuator travel
- This value specifies the actuator travel determined during initialization, according to the indication at the end of an initialization phase. Prerequisite for linear actuators: Specification of the lever arm with parameter "3.YWAY".
- 8 TUP** Actuating time up
and
- 9 TDOWN** Actuating time down
- These values indicate the actuating times that were determined during initialization. The unit is seconds.
- 10 LEAK** Leakage
- If a leakage measurement was initiated during initialization, the leakage value can be read off here in %/min.

11 PST

Monitoring of the partial stroke test

The measured step time of the last partial stroke test is displayed here. A partial stroke test can be triggered manually by pressing the Greater Than button, or a partial stroke test that is just being performed can be interrupted.

The following states are shown in the display:

- OFF
The partial stroke test function is deactivated in the configuration menu.
- Fdlni (Failed PST Initialization)
The partial stroke test reference step time measurement failed.
- notSt (No Test)
No partial stroke test carried out yet.
- ###.# (measured step time in seconds)
The last partial stroke test was carried out successfully.
- SdtSt (Stopped Test)
The last partial stroke test was interrupted.
- FdtSt (Failed Test)
The last partial stroke test failed.

The following status messages appear on pressing the Greater Than button:

- notoL (No Tolerance)
The control valve is outside the tolerance range for starting the partial stroke test. No manual partial stroke test has been started.
- Strt (Start)
A manual partial stroke test was started after pressing the button for five seconds.
- StoP (Stop)
The currently performed partial stroke test is interrupted.

12 PRPST

Time since the last partial stroke test

The time that has passed since the last partial stroke test is displayed here (in days). The following status messages can also appear:

- notSt (No Test)
No partial stroke test carried out yet.
- SdtSt (Stopped Test)
The last partial stroke test was interrupted.
- FdtSt (Failed Test)
The last partial stroke test failed.

13 NXPST	<p>Time until the next partial stroke test</p> <p>The time until the next partial stroke test is displayed here (in days). Conditions are that the partial stroke test is deactivated in the configuration menu and a test interval is set. If one of these two conditions is not fulfilled "OFF" appears in the display.</p>
14 DEVI	<p>General control valve malfunction</p> <p>This value provides information on the current dynamically determined deviation from the model behavior. If the basic function is deactivated in the configuration menu "OFF" is displayed.</p>
15 ONLK	<p>Pneumatic leakage</p> <p>The current leakage indicator is displayed here. If the leakage detection is deactivated in the configuration menu "OFF" is displayed.</p>
16 STIC	<p>Slipstick effect</p> <p>The filtered step height value cause by slipstick is displayed here in percent. If the function is deactivated in the configuration menu, "OFF" is displayed.</p>
17 ZERO	<p>Zero point offset</p> <p>Display of the current displacement of the lower limit stop compared to its initialization value. Condition for the determination is the activation of the "bottom tight closing function" (parameter "39.YCLS" in the configuration menu). If the basic function is deactivated in the configuration menu "OFF" is displayed.</p>
18 OPEN	<p>Shifting the upper stop</p> <p>Display of the current displacement of the upper limit stop compared to its initialization value. Condition for the determination is the activation of the "top tight closing function" (parameter "39.YCLS" in the configuration menu). If the basic function is deactivated in the configuration menu "OFF" is displayed.</p>

19 PAVG

Average position value

The comparison average calculated last is displayed here. There are also the following status messages:

- OFF
The basic function is deactivated in the configuration menu.
- IdLE (inactive)
The function has not been started yet.
- rEF (reference average is calculated)
The function was started and the reference interval is currently active.
- COMP (comparison average is calculated)
The function was started and the comparative interval is currently active.

www.DataSheet4U.com

20 P0

Potentiometer value lower stop
and

21 P100

Potentiometer value upper stop

These two values indicate the measured values of the position displacement sensor (potentiometer) at the lower or upper limit stop, as determined during the automatic initialization. With manual initialization, the values of the manually approached end positions can be found here.

22 IMPUP

Pulse length up
and

23 IMPDN

Pulse length down

During the initialization phase, the smallest pulse lengths are determined, with which a movement of the actuator can be achieved. They are determined separately for the "Up" direction and the "Down" direction and displayed here.

These two parameters can be set for special applications (see chapter 4.7, page 143).

24 DBUP

Dead zone up
and

25 DBDN

Dead zone down

The dead zone of the controller in "Up" direction or in "Down" direction is displayed here. The values correspond either to the manually set value of parameter "34.DEBA" or to the value automatically adapted by the device if "DEBA" was set to "Auto".

26 SSUP Short step zone up
and
27 SSDN Short step zone down

The short step zone is the range of the controller, in which pulse-shaped excitation signals are output. The pulse length is proportional to the control deviation. If the control deviation is not within the short step zone, then the valves are activated in permanent contact.

These two parameters can be set for special applications (see chapter 4.7, page 143).

28 TEMP Current temperature

Current temperature in the positioner housing. The sensor is on the electronic circuit board.

The temperature display can be switched between °C and °F by pressing the decrement button.

29 TMIN Minimum temperature (min/max pointer)
and

30 TMAX Maximum temperature (min/max pointer)

The minimum and maximum temperature in the housing interior is determined continuously in the form of a min/max pointer and saved and can only be reset at the factory.

31 T1 to 39 T9 Number of operating hours in temperature range T1 to T9

The device gives statistical information as to how long and in which temperature ranges it was operated. For this purpose, the measured temperature is averaged for each hour and the counter that is assigned to the relevant temperature range is incremented every hour. This allows conclusions to be made about past operating conditions of the device and the entire control valve.

The temperature ranges are divided as follows:

	T1	T2	T3	T4	T5	T6	T7	T8	T9
Temperature range [°C]	≥ -30	≥ -30 < -15	≥ -15 < 0	≥ 0 < 15	≥ 15 < 30	≥ 30 < 45	≥ 45 < 60	≥ 60 < 75	≥ 75

40 VENT1 Number of switching operations pilot valve 1
and

41 VENT2 Number of switching operations pilot valve 2

These two counters add up the activation processes of the pilot valves and are for the assessment of the switching dependency.

42 STORE

Save maintenance data

Pressing the increment button  for at least 5 seconds triggers a memory function. In doing so, the diagnostic data 7 to 18 is saved in a non-volatile memory as the “data of the last maintenance”. This diagnostic data consists of selected values that, when changed, can provide information on the mechanical wear of the valve.

Normally, this function is operated via PDM, menu item: Device→Save maintenance info. The comparison of the data of the last maintenance to the current data is possible via PDM.

43 PRUP

Prediction up

44 PRDN

Prediction down

see chapter 4.7, page 143.

www.DataSheet4U.com

**45 WT00 to
52 WT95**

Number of operating hours in actuating range WT00 to WT95

If the positioner is in automatic mode, statistical information is generated as to how long a valve or a flap was operated in which section of the actuating range. For this purpose, the entire actuating range (0 to 100 %) is divided into 8 sections (actuating ranges). The positioner registers the current position continuously and increments the operating hours counter that is assigned to the relevant section (actuating range) every hour. This allows conclusions to be made about past operating conditions and is in particular for the assessment of the control characteristics of the control loop or of the entire control valve.

The actuating range is divided as follows:

Actuating range	WT00	WT05	WT10	WT30	WT50	WT70	WT90	WT95
Actuating range section	< 5 %	≥ 5 % < 10 %	≥ 10 % < 30 %	≥ 30 % < 50 %	≥ 50 % < 70 %	≥ 70 % < 90 %	≥ 90 % < 95 %	≥ 95 %

The 8 operating hours counters can be set to zero together by pressing the increment button (for at least 5 seconds).

TIP: Since the actuating ranges are arranged at the end of the diagnosis menu with numbers 45 to 52, press the decrement button several times in addition to the operating mode button. That is how you access diagnosis numbers 45 to 52 quickly.

53 MA

Setpoint current

You can have the current setpoint displayed here in mA.



NOTE

All diagnosis values are updated every 15 minutes in the non-volatile memory so that only the values of the past quarter of an hour are lost if there is a power failure.

4.5.3 Online diagnosis

While the positioner is in operation, some important values and parameters are monitored on a continuous basis. In “Configuration” mode, you can configure this monitoring in such a way that the fault message output is activated when a certain event occurs, such as e.g. when a limit is exceeded.

Table 4-2, page 133, shows which events can activate the fault message output and the alarm outputs, how the parameters need to be set for this event to be monitored, when the fault messages disappears again and what the possible causes of the malfunction are.

In automatic and manual mode, the display shows what triggered the fault message when the fault message output reacts. The two numbers at the bottom left indicate the relevant error code. If several triggers occur simultaneously, they are display in succession cyclically. The device status that also includes all fault messages, can be called using command #48 via HART.

The parameters of the extended diagnostics allow error messages to be displayed in one, two or three levels. In addition to the fault message output, alarm outputs 1 and 2 are then used. For this purpose, parameter 51.XDIAG needs to be set according to the following table:

Settings of 51.XDIAG	Message by
Off	Extended diagnostics not activated
On1	Fault message output for threshold 3 error messages (one-level)
On2	Fault message output for threshold 3 error messages and alarm output 2 for threshold 2 error messages (two-level)
On3	Fault message output for threshold 3 error messages and alarm output 2 for threshold 2 error messages and alarm output 1 for threshold 1 error messages (three-level)

Error code	three-level	Event	Parameter-setting	Error message disappears if...	Possible causes
41	no	Remaining control deviation	always active	... the control deviation has disappeared again.	Compressed air missing, actuator fault, valve fault (e.g. blockage).
42	no	Device not in automatic mode	47.4FCT= 4nA or = 4nAB	... the device is switched to automatic mode.	The device is configured or is in manual mode.
43	no	Binary input BE1 or BE2 active	47.4FCT= 4nAB and binary function BIN1 or BIN2 at "on"	... the binary input is no longer activated.	The contact connected to the binary input became active (e.g. stuffing box monitoring, overpressure, temperature switch).
44	yes	Limit Stroke number exceeded	L.4STRK≠OFF	... the stroke counter is reset or the thresholds are increased	The sum of the distance covered by the actuator exceeds one of the set thresholds.
45	yes	Direction change limit exceeded	O.4DCHG≠OFF	... the direction change counter is reset or the thresholds are increased	The number of changes of direction exceeds one of the set thresholds.
46	yes	Lower limit stop limit exceeded	F.4ZERO≠OFF 39.YCLS = do or up do	... the deviation of the stop disappears or the device was re-initialized.	Wear of the valve seat, deposit or foreign matter in the valve seat, mechanical misadjustment, friction clutch misadjusted.
47	yes	Limit of upper limit stop exceeded	G.4OPEN≠OFF 39.YCLS = up or up do	... the deviation of the stop disappears or the device was re-initialized.	Wear of the valve seat, deposit or foreign matter in the valve seat, mechanical misadjustment, friction clutch misadjusted.
48	no	Limit Dead zone adaptation exceeded	E.4DEBA≠OFF 34.DEBA = Auto	... the value has fallen below the limit again.	Increased stuffing box friction, mechanical batches of the position feedback.
49	yes	Partial stroke test exceeds reference step time	A.4PST≠OFF	... a partial stroke test is performed successfully within the reference step time or the function is deactivated.	Valve jams or is rusted in place, increased friction
10	yes	General control valve malfunction	b.4DEVI≠OFF	... the position is back within a narrow corridor between guide value and model, or the function is deactivated.	actuator fault, valve fault, valve jams, increased friction, compressed air drop
11	yes	Pneumatic leakage	C.4LEAK≠OFF	... the leakage falls below the set thresholds, or the function is deactivated.	Pneumatic leakage

Error code	three-level	Event	Parameter-setting	Error message disappears if...	Possible causes
12	yes	Slipstick effect occurs	d. $\text{STIC} \neq \text{OFF}$... no more slipstick can be detected, or the function is deactivated.	Increased slipstick, valve no longer moves constantly but judders instead
13	yes	Temperature short of	H. $\text{TMIN} \neq \text{OFF}$... the lower temperature threshold values are no longer fallen short of.	Ambient temperature too low
14	yes	Temperature exceeded	J. $\text{TMAX} \neq \text{OFF}$... the upper temperature thresholds are no longer exceeded.	Ambient temperature too high
15	yes	Position average deviates from the reference value	P. $\text{PAVG} \neq \text{OFF}$... after a comparison interval, a position average is calculated that is within the reference value thresholds or the function is deactivated.	In the last comparison interval, the valve trajectory changed so much that a deviating position average was calculated.

Table 4-2 Events that can activate the fault message output

Explanations for the “Error codes” column:

- 1 Control deviation monitoring**

In automatic mode, the deviation between the setpoint and actual value is monitored continuously. According to the setting of parameter 48. TIM , the monitoring time for setting the fault messages, and 49. LIM , the response threshold of the fault message, the fault message is activated if the control deviation remains. As soon as the control deviation falls below the response threshold again, the fault message is cancelled.
- 2 Automatic mode monitoring**

If parameter “47. FCT ”, the fault message output function, is set accordingly, a fault message is generated if the device is not in automatic mode. In this way, e.g. the control system can be warned if the device was switched to manual mode or configuration on location.
- 3 Binary input BE1 or BE2 active**

If parameter “47. FCT ”, the fault message output function, and parameter “42. BIN1 ”, the binary input 1 function, are set accordingly, a fault message is generated when the binary input is activated. This can be e.g. a stuffing box monitoring switch, a temperature switch or a limit switch (e.g. for pressure).

Binary input 2 (for the alarm unit option) can be configured in the same way.

4

Stroke number monitoring

5

Monitoring of the number of changes of direction

The two values, number of strokes and number of changes of direction, are compared to the threshold values on a continuous basis. These values result from the parameters "L1.LIMIT" to "L4.FACT3" and "O1.LIMIT" to "O4.FACT3". If they are exceeded, depending on the operating mode of the extended diagnostics, the fault message output reacts, and possibly also the alarm outputs. The two functions can be deactivated by the parameter setting "OFF" for "L.4STRK" or "O.4DCHG".

6

Monitoring of the lower limit stop (valve seat)

7

Monitoring of the upper limit stop

The monitoring of the lower limit stop is activated if parameter "F.4ZERO" has a value \neq OFF. This function can be used e.g. to detect valve seat errors. If the limit is exceeded, this can be an indication of deposits or foreign particles on the valve seat. If the limit is fallen short of, wear to the valve seat or reactor body could be the cause. The mechanical misadjustment of the position feedback can also trigger this error message.

Monitoring takes place every time the valve is in "bottom tight closing" position. In doing so, the current position is compared to the position that was determined as lower end stop during the initialization phase. The activation of the "bottom tight closing function" (parameter "39.YCLS") is therefore prerequisite.

Example: 3% is set as value. For "bottom tight closing", the 0% position is normally established. If a value of $>3\%$ or $<-3\%$ is determined instead, a fault is reported.

The fault message remains activated until either a subsequent monitoring process remains within the tolerance range or a re-initialization is carried out. The deactivation of the monitoring process ("F.4ZERO"=OFF) also deletes any fault messages.

This monitoring function does not provide any useful results if the stops were not determined automatically during initialization but instead the limits were set by hand (manual initialization, "5.INITM").

An appropriate diagnosis was carried out for the upper limit stop. The parameter "G.4OPEN" is used to set this limit. The activation of the "top tight closing function" (parameter "39.YCLS") is therefore prerequisite.

8

Dead zone adaptation monitoring

If, during the automatic adaptation of the dead zone (parameter 34.DEBA=Auto) the dead zone increases disproportionately during operation, this is an indication of a fault in the system (e.g. significantly increased stuffing box friction, play in the position displacement sensor, leakage). Therefore a limit can be specified for this value ("E1.LEVL3", threshold for dead zone monitoring) that activates the fault message output if it is exceeded.

- 9 Partial stroke test exceeds reference step time**
- This error message appears on the one hand if a manual or cyclic partial stroke test is triggered and the test cannot be started because the valve is not within the start tolerance range. The error message also appears if one of the three thresholds of the partial stroke test that are a result of the reference step time (A6.PSTIN) times factors (A7.FACT1 to A9.FACT3) is violated. How serious the error message is, can be seen at the bar graph on the right side of the display. At the same time, the severity of the error message is output via the fault message output or the alarm outputs, according to the operating mode of the extended diagnostics.
- 10 General control valve malfunction**
- The monitoring of the operational behavior triggers if the actual valve position leaves a narrow corridor between guide value and expected position sequence. In this case, the deviation between expected and actual position sequence is filtered and output and compared to the set thresholds that are the result of the limit (b2.LIMIT) times the factors (b3.FACT1 to b5.FACT3).
- 11 Pneumatic leakage**
- This error message appears if the leakage indicator exceeds the set thresholds. Note that the function can only take effect with its entire sensitivity if a ramp test is performed to set the leakage indicator after initialization (see Explanations on C1.LIMIT).
- 12 Slipstick effect too high**
- If the slipstick of the control valve is increased during operation of if an increasing number of slip jumps are detected, the relevant limits can be exceeded, resulting in an error message.
- 13 Temperature fallen short of**
- This error message appears if the lower temperature limit thresholds are fallen short of.
- 14 Temperature exceeded**
- This error message appears if the upper temperature limit thresholds are exceeded.
- 15 Monitoring of the position average**
- If a position average is calculated when a comparison interval passes that deviates from the reference value by more than the set thresholds, this error message triggers.

4.5.4 Fault correction

Guide

see	Table			
In which operating mode does the fault occur?				
• Initialization	5			
• Manual mode and automatic mode	6	7	8	9
In which environment and under which basic conditions does the fault occur?				
• Wet environment (e.g. heavy rain or continuous condensation)	6			
• Vibrating (oscillating) control valves	6	9		
• Stress due to knocks or shocks (e.g. steam pulses or flaps breaking away)	9			
• damp (wet) compressed air	6			
• dirty compressed air (contaminated with solid particles)	6	7		
When does the fault occur?				
• constantly (reproducible)	5	6	7	8
• sporadically (not reproducible)	9			
• usually after a certain operation time	6	7	9	

Fault indication (symptoms)	possible cause(s)	Remedies
<ul style="list-style-type: none"> SIPART PS2 stops during "RUN 1". 	<ul style="list-style-type: none"> Initialization started from end position <u>and</u> reaction time of max. 1 min. not waited for. Mains pressure not connected or insufficient. 	<ul style="list-style-type: none"> Up to 1 min. delay time required. Do not start initialization from end position. Secure the mains pressure.
<ul style="list-style-type: none"> SIPART PS2 stops during "RUN 2". 	<ul style="list-style-type: none"> Transmission ratio selector and parameter 2 (YAGL) as well as actual stroke do not match. Stroke not correctly set for lever. Piezo valve(s) do(es) not switch (see table 6). 	<ul style="list-style-type: none"> Check settings: see leaflet: figure "device view (7)" as well as parameters 2 and 3 Check stroke setting at lever. see table 2
<ul style="list-style-type: none"> SIPART PS2 stops during "RUN 3". 	<ul style="list-style-type: none"> Actuating time too high. 	<ul style="list-style-type: none"> Open reactor completely and/or set PZ pressure (1) to maximum permissible value. If necessary, use booster.
<ul style="list-style-type: none"> SIPART PS2 stops during "RUN 5" and does not reach "FINISH" (delay time: > 5 min). 	<ul style="list-style-type: none"> "Batches" (play) in the positioner – actuator – control valve system 	<ul style="list-style-type: none"> Part-turn actuator: Check if set screw of the coupling wheel is inserted firmly Linear actuator: Check if lever is connected firmly to positioning shaft. Eliminate any other play between actuator and control valve.

Table 5

Fault indication (symptoms)	possible cause(s)	Remedies
<ul style="list-style-type: none"> For SIPART PS2, "CPU test" flashes in the display (approx. every 2 sec). Piezo valve(s) do(es) not switch. 	<ul style="list-style-type: none"> Water in the pneumatic block (due to wet compressed air) 	<ul style="list-style-type: none"> At an early stage, this fault can be eliminated by subsequent operation with dry air (if necessary, in the temperature cabinet at 50 to 70°C).
<ul style="list-style-type: none"> In manual or automatic mode, the actuator cannot be moved or only in one direction. 	<ul style="list-style-type: none"> Moisture in the pneumatic block 	<ul style="list-style-type: none"> Otherwise: Repair (see chapter 5, page 145)
<ul style="list-style-type: none"> Piezo valve(s) do(es) not switch (no quiet "clicking" can be heard when the + or – button is pressed in manual mode). 	<ul style="list-style-type: none"> Screw between shrouding cover and pneumatic block not tightened firmly or cover jammed. 	<ul style="list-style-type: none"> Tighten screw, if necessary eliminate jam.
	<ul style="list-style-type: none"> Dirt (chips, particles) in the pneumatic block 	<ul style="list-style-type: none"> Repair (see chapter 5, page 145) or new device; integrated fine screen, also replace and clean.
	<ul style="list-style-type: none"> Deposits on contact(s) between electronics board and pneumatic block can develop due to abrasion as a result of continuous high vibration stress. 	<ul style="list-style-type: none"> Clean all contact surfaces with spirit; if necessary, re-bend the pneumatic block springs slightly.

Table 6

Fault indication (symptoms)	possible cause(s)	Remedies
<ul style="list-style-type: none"> Actuator does not move 	<ul style="list-style-type: none"> Compressed air < 1.4 bar 	<ul style="list-style-type: none"> Set supply air pressure to > 1.4 bar.
<ul style="list-style-type: none"> Piezo valve(s) do(es) not switch (quiet "clicking" can be heard however when the + or – button is pressed in manual mode). 	<ul style="list-style-type: none"> Reactor valve(s) closed (screw(s) at the right-hand stop) 	<ul style="list-style-type: none"> Open reactor screw(s) (see leaflet, figure "device view (6)" by turning it/them anti-clockwise.
	<ul style="list-style-type: none"> Dirt in the pneumatic block 	<ul style="list-style-type: none"> Repair (see chapter 5, page 145) or new device; integrated fine screen, also replace and clean.
<ul style="list-style-type: none"> A piezo valve switches continuously in stationary automatic mode (constant setpoint) and in manual mode. 	<ul style="list-style-type: none"> Pneumatic leakage in the positioner – actuator system Start leakage test in "RUN 3" (initialization)!!! 	<ul style="list-style-type: none"> Eliminate leakage in the actuator and/or supply line If the actuator is intact and the supply line is leak-tight: Repair (see chapter 5, page 145) or new device
	<ul style="list-style-type: none"> Dirt in the pneumatic block (see above) 	<ul style="list-style-type: none"> see above

Table 7

Fault indication (symptoms)	possible cause(s)	Remedies
<ul style="list-style-type: none"> Both piezo valves switch continuously and alternately in stationary automatic mode (constant setpoint) and in manual mode, actuator oscillates around a mean value. 	<ul style="list-style-type: none"> Too much slipstick of stuffing box of control valve or actuator 	<ul style="list-style-type: none"> Reduce slipstick or increase dead zone of SIPART PS 2 (dEbA parameter) until oscillation stops.
	<ul style="list-style-type: none"> Batches (play) in the positioner – actuator – control valve system 	<ul style="list-style-type: none"> Part–turn actuator: Check if set screw of the coupling wheel is inserted firmly Linear actuator: Check if lever is connected firmly to positioning shaft. Eliminate any other play between actuator and control valve.
	<ul style="list-style-type: none"> Actuator too fast 	<ul style="list-style-type: none"> Increase actuating times via reactor screws. If fast actuating time is required, increase dead zone (dEBA parameter) until oscillation stops.
<ul style="list-style-type: none"> SIPART PS 2 does not "drive" control valve up to the stop (at 20 mA). 	<ul style="list-style-type: none"> Supply pressure too low. Load of the feeding controller or system output is too low. 	<ul style="list-style-type: none"> Increase supply pressure Interconnect load converter Select 3/4 transmitter operation

Table 8

Fault indication (symptoms)	possible cause(s)	Remedies
<ul style="list-style-type: none"> Zero point misadjusts sporadically (> 3 %). 	<ul style="list-style-type: none"> Stress caused by knocks or shocks result in acceleration values that are so high that the friction clutch is misadjusted (e.g. with "steam pulses" in steam lines) 	<ul style="list-style-type: none"> Eliminate causes of shock stress. Re-initialize positioner.
<ul style="list-style-type: none"> Complete device function failure: also no indication in the display 	<ul style="list-style-type: none"> Electrical power supply insufficient 	<ul style="list-style-type: none"> Check electrical power supply.
	<ul style="list-style-type: none"> In the event of continuous high vibration stress (vibrations): Screws on the electrical connecting terminals can loosen. Electrical connecting terminals and/or electronic components can loosen due to vibrations. 	<ul style="list-style-type: none"> Tighten screws and secure them with locking varnish. Repair (see chapter 5, page 145) For prevention purposes: Fit SIPART PS 2 on shock mounts.

Table 9

4.6 Meaning of the other display text

Remarks on the tables:

nn stands for variable numerical values
 ♪ Error symbol
 / (slash): the text segments to the left and right of the slash flash alternately

Messages before the installation phase (initial start-up):

	Upper line	Lower line	Meaning/cause	Measure
CPU START	x	x	Message after applying the electrical power supply	<ul style="list-style-type: none"> Wait
P nnn.n	x		Potentiometer voltage when positioner is not initialized (P manual mode) (actual position value in % of measuring range)	<ul style="list-style-type: none"> Check with the "+" and "-" buttons whether the entire actuator travel can be moved along and that "P----" is never displayed Perform initialization
P----	x		Measuring range exceeded, potentiometer is in the inactive zone, switch transmission ratio selector or effective lever arm have not been adapted to the actuator travel	<ul style="list-style-type: none"> Switch transmission ratio selector to 90 degrees for part-turn actuators Adjust effective lever length for linear actuators to measuring range
NOINI		x	Positioner is not initialized	<ul style="list-style-type: none"> Start initialization

Messages during the installation phase:

	Upper line	Lower line	Meaning/cause	Measure
P--	x		See above	See above
RUN 1		x	Initialization has been started, part 1 is active (direction of action is being determined)	<ul style="list-style-type: none"> Wait
RUN 2		x	Initialization, part 2 is active (actuator travel check and determination of the end stops)	<ul style="list-style-type: none"> Wait
RUN 3		x	Initialization, part 3 is active (determination and display of the actuating times)	<ul style="list-style-type: none"> Wait
RUN 4		x	Initialization, part 4 is active (determination of the minimum actuator increment length)	<ul style="list-style-type: none"> Wait
RUN 5		x	Initialization, part 5 is active (optimization of the transient response)	<ul style="list-style-type: none"> Wait until "FINSH" is displayed (initialization completed successfully) Press the operating mode button briefly to acknowledge and exit the configuration level by pressing it continuously
YEND1		x	<u>only for manual initialization</u> first end position can be approached	<ul style="list-style-type: none"> Approach first end position with the "+" or "-" button Press operating mode button to acknowledge
YEND2			<u>only for manual initialization</u> second end position can be approached	<ul style="list-style-type: none"> Approach second end position with the "+" or "-" button Press operating mode button to acknowledge
RANGE		x	<u>only for manual initialization</u> End position or measuring span are outside the permitted measuring range	<ul style="list-style-type: none"> Press the "+" and "-" buttons to approach another end position and acknowledge with the operating mode button, or adjust the friction clutch until "ok" is displayed and acknowledge with the operating mode button or cancel the initialization by pressing the operating mode button, switch to P manual mode and correct the actuator travel and the position displacement sensor
ok			<u>only for manual initialization</u> permitted measuring range of the end positions has been reached	<ul style="list-style-type: none"> Acknowledge with the operating mode button, the remaining steps ("RUN1" to "FINSH") run automatically
RUN 1/ ERROR		x	Error in RUN 1 no movement e.g. due to insufficient compressed air	<ul style="list-style-type: none"> Make sure there is sufficient compressed air Open reactor(s) Restart initialization
↳ d__U		x	Bar graph display of the zero point Zero point is outside the tolerance range	<ul style="list-style-type: none"> Use friction clutch to set between "P 4.0" and "P 9.9" (>0<) Continue with the "+" or "-" button
SEt MIDDLE	x	x	Friction clutch has been misadjusted; no "P 50.0" display if the lever is in horizontal position	<ul style="list-style-type: none"> With linear actuators, press the "+" and "-" buttons to move the lever at right angles to the spindle Press operating mode button briefly to acknowledge (initialization is continued)

	Upper line	Lower line	Meaning/cause	Measure
↳ UP >		x	"UP" tolerance range exceeded or inactive zone of the potentiometer passed	<ul style="list-style-type: none"> • Increase effective lever length for linear actuators or switch transmission ratio selector to 90 degrees • Press operating mode button briefly to acknowledge • Restart initialization
↳ 90_95		x	Only possible for part-turn actuators: Actuator travel is not within the range of 90 to 95%	<ul style="list-style-type: none"> • Use the "+" and "-" buttons to move it to the range between 90 and 95% • Press operating mode button briefly to acknowledge
↳ U-d>		x	"Up-Down" measuring span fallen short of	<ul style="list-style-type: none"> • Reduce effective lever length for linear actuators or switch transmission ratio selector to 33 degrees • Press operating mode button briefly to acknowledge • Restart initialization
U nn.n D->U	x	x	Display of actuating time "Up"	<ul style="list-style-type: none"> • Wait, <u>or</u> • press the "-" button to interrupt the initialization process to change the actuating time, <u>or</u> • activate the leakage test with the "+" button
d nn.n U->d	x	x	Display of the actuating time "Down"	<ul style="list-style-type: none"> • Wait, <u>or</u> • press the "-" button to interrupt the initialization process to change the actuating time, <u>or</u> • activate the leakage test with the "+" button
NOZZL		x	Actuator stationary (initialization was interrupted with the "-" button during the indication of the actuating speed)	<ul style="list-style-type: none"> • Actuating time can be changed by adjusting the reactor(s) • press the "-" button to repeat the determination of the actuating speed • continue with the "+" button
TEST LEAKG	x	x	Leakage test active ("+" button was pressed during the indication of the actuating speed)	<ul style="list-style-type: none"> • Wait one minute • continue with the "+" button
nn.n ° oMIN	x	x	Value and unit of the result after the leakage test	<ul style="list-style-type: none"> • Eliminate if leakage value is too great • continue with the "+" button
nn.n FINSH	x	x	Initialization was completed successfully, possibly along with the indication of the actuator travel or angle	<ul style="list-style-type: none"> • Press the operating mode button briefly to acknowledge and exit the configuration level by pressing it continuously

Messages on exiting configuration mode:

	Upper line	Lower line	Auto- matic	Manua l mode	P manual mode	Meaning/cause	Measure
4.nn.nn VER	x					Software version	<ul style="list-style-type: none"> Wait
Error SLnn	x					Monotony violation of the free characteristic curve at vertice n	<ul style="list-style-type: none"> Correct value

Messages during operation:

www.DataSheet4U.com

	Upper line	Lower line	Auto- matic	Manua l mode	P manual mode	Meaning/cause	Measure
CPU START	x					Message after applying the electrical power supply	<ul style="list-style-type: none"> Wait
HW / ERROR		x				Hardware error	<ul style="list-style-type: none"> Replace electronics
NOINI		x			x	Positioner is not initialized	<ul style="list-style-type: none"> Start initialization
nnn.n	x		x	x		Actual position [in %] with initialized positioner. Flashing decimal point indicates communication with a class 2 master	
AUTnn		x	x			Automatic mode (nn = setpoint)	
MANnn				x		Manual mode (nn = setpoint)	<ul style="list-style-type: none"> Press operating mode button to switch to automatic mode
oFL / 127.9	x		x	x		Display range was exceeded. Possible causes: <ul style="list-style-type: none"> friction clutch <u>or</u> transmission ratio selector were misadjusted <u>or</u> positioner was fitted on another actuator without re-initialization. 	<ul style="list-style-type: none"> Adjust friction clutch in such a way that the indication of the actual value remains between 0.0 and 100.0 on moving the actuator or switch over the transmission ratio selector or set to the factory setting (preset) and initialize
EXSTP		x	x			Actuator was stopped via binary input	
EX UP		x	x			Actuator is moved to the upper stop via binary input	
EXDWN		x	x			Actuator is moved to the lower stop via binary input	
EXTPst						Partial stroke test was activated e.g. via binary input	
InPSt						cyclic partial stroke test	
HTCNF		x	x	x	x	HARD configuration running	

4.7 Optimizing the controller data

The data for the control quality that was automatically determined during initialization is optimized for short compensation with low overshooting. In special cases (e.g. extremely small and therefore particularly fast actuators or for operation with boosters), you might want to modify this data specifically for faster compensation or a greater damping effect. The following six parameters are available for this purpose:

13 Pulse length up 14 Pulse length down

This is for defining the smallest pulse lengths with which the actuator is to move for each actuating direction. The optimal value mainly depends on the volume of the actuator.

Small values result in small actuating increments and frequent activation of the actuator. Bear in mind that if the values are too small, there will be no movement. Large values are advantageous for large actuator volumes. Also bear in mind that large actuating increments for small actuators also result in large movements.

17 Short step zone up 18 Short step zone down

The short step zone is the range of the control deviation between the fast step zone and the dead band in which the actuator is activated by pulses.

In the case of small control deviations, small values already cause relatively high actuating speeds and can therefore result in overshooting. Large values in particular reduce overshooting in the case of large changes in the nominal value and result in slow actuating speeds near the compensated status.

34 Prediction up 35 Prediction down

This parameter has the same effect as a damping factor and is used to set the control dynamics.

Small values cause fast compensation with overshooting. Large values cause slow compensation without overshooting.

We recommend that you perform an automatic initialization first and only then adapt the parameter determined by the positioner to your own special requirements.

TIP: To have a fixed reference value, it is helpful if you specify a fixed value for the dead zone (DEBA parameter) instead of "Auto" for the optimization of your particular controller.

You select the parameters above from the diagnosis menu in the accustomed manner and activate the joint adjustment by pressing the increment or decrement button for 5 seconds. If you now adjust the relevant parameter, the new value is activated immediately. You can test the effects of the new values on the controller results immediately.

When you quit the diagnosis menu, the parameter adjustment option is deactivated again.

The positioner is largely maintenance-free. The positioners are fitted with filters in the pneumatic connections as protection against coarse particles of dirt. If the pneumatic energy supply contains particles of dirt, the filters may clog and impair the function of the positioner. In this case the filters can be cleaned as follows.

www.DataSheet4U.com

Positioner in metal housing and explosion proof version

1. Switch off the pneumatic power supply and remove the pipes.
2. Remove the metal filters carefully from the holes and clean (e.g. with compressed air).
3. Insert the filters.
4. Re-connect the pipes and supply pneumatic energy.

Positioner in plastic housing

Removal

1. Switch off the pneumatic power supply and remove the pipes.
2. Unscrew the cover
3. Remove the three screws from the pneumatic connector strip.
4. Remove the filters and O-rings behind the connector strip.
5. Clean the filters (e.g. with compressed air).

Installation

6. First insert the filters in the recesses in the plastic housing and then place the O-rings on the filters.
7. Align the pneumatic connector strip on the two lugs and screw tight with the three self-tapping screws.

Important:

Make sure that the same thread is used. To do this turn the screws counterclockwise until they snap into the thread audibly. Only then should you tighten the screws.

8. Replace the cover and screw it tight.
9. Re-connect the pipes and supply pneumatic energy.



DANGER

Electrostatic charging must be prevented in hazardous areas. These could be caused by example when cleaning the positioner in plastic housing with a dry cloth.

Repair/Upgrade

Faulty equipment should be sent to the repair department with details of the fault and its origin. When ordering replacement equipment, please specify the serial number of the original equipment. You will find the serial number on the name plate.

Address of the responsible repair location, your contact, lists of spare parts etc. can all be found on the Internet, under:

www.siemens.com/automation/services&support or
www.automation.siemens.com/partner

Technical Data

6

General data for basic device 6DR50xx
6DR51xx
6DR52xx
6DR53xx

www.DataSheet4U.com (see following pages)

Technical specifications

SIPART PS2 (all versions)

General data

Travel range (linear actuators)	3 ... 130 mm (0.12 ... 5.12 inch) (angle of feedback shaft 16 ... 90°)
Angle of rotation (part-turn actuators)	30 ... 100°
Installation	
• On linear actuators	Using attachment set 6DR4004-8V and where necessary with an additional lever arm
• On part-turn actuators	Using attachment set 6DR4004-8D on actuators with mounting plane according to VDI/VDE 3845 and DIN 3337: The required mounting console has to be provided on the actuator side; shaft with groove and female thread M6
Controller	
• Five-point switch	Self-adjusting
• Dead zone	
- dEbA = Auto	Self-adjusting or can be set as fixed value
- dEbA = 0.1 ... 10%	Self-adjusting or can be set as fixed value
A/D converter	
• Scan time	10 ms
• Resolution	≤ 0.05%
• Transmission error	≤ 0.2%
• Temperature effect	≤ 0.1%/10 K (≤ 0.1%/18 °F)
Cycle time	
• 20 mA/HART device	20 ms
• PA device	60 ms
• FF device	60 ms (min. loop time)
Binary input BE1 (terminals 9/10; electrically connected to the basic device)	Suitable only for floating contact; max. contact load < 5 mA with 3 V device)
Degree of protection ¹⁾	IP66 to EN 60 529/NEMA 4x
Mounting position	Any; pneumatic connections and exhaust opening not facing up in wet environment
CE marking	Conformity as regards EMC Directive 89/336 EC in accordance with the following standards
EMC requirements	EN 61326/A1 Appendix A.1 and NAMUR NE21 August 98
Material	
• Housing	
- 6DR5..0-... (plastic)	Glass-fiber-reinforced Macrolon
- 6DR5..1-... (metal)	GD AISi12
- 6DR5..2-... (stainless steel)	Austenitic stainless steel mat. No. 1.4581
- 6DR5..5-... (metal, pressure-proof)	GK AISi12
• Pressure gauge block	Aluminium AIMgSi, anodized
Vibration resistance	
• Harmonic oscillations (sine-wave) according to DIN EN 60062-2-6/05.96	3.5 mm (0.14 inch), 2 ... 27 Hz 3 cycles/axis 98.1 m/s ² (321.84 ft/s ²), 27 ... 300 Hz, 3 cycles/axis

• Bumping (half-sine) to DIN EN 60068-2-29/03.95	150 m/s ² (492 ft/s ²), 6 ms, 1000 shocks/axis
• Noise (digitally controlled) to DIN EN 60068-2-64/08.95	10 ... 200 Hz; 1 (m/s ²) ² /Hz (3.28 (ft/s ²) ² /Hz) 200 ... 500 Hz; 0.3 (m/s ²) ² /Hz (0.98 (ft/s ²) ² /Hz) 4 hours/axis
• Recommended continuous duty range of the complete fitting	≤ 30 m/s ² (≤ 98.4 ft/s ²) without resonance sharpness
Weight, basic device	
• Plastic casing	Approx. 0.9 kg (0.90 kg)
• Metal casing, aluminium	Approx. 1.3 kg (1.30 kg)
• Metal casing, stainless steel	Approx. 3.9 kg (3.90 kg)
• Metal casing EEx d version	Approx. 5.2 kg (11.46 lb)
Dimensions	See Dimensional drawings
Climate class 4	To DIN EN 60721-3-4
• Storage ²⁾	1K5, but -40 ... +80 °C (1K5, but -40 ... +176 °F)
• Transport ²⁾	2K4, but -40 ... +80 °C (2K4, but -40 ... +176 °F)
• Operation ³⁾	4K3, but -30 ... +80 °C (4K3, but -22 ... +176 °F)

Certificate and approvals

Classification according to pressure equipment directive (DRGL 97/23/EC)	For gases of fluid group 1, complies with requirements of article 3, paragraph 3 (sound engineering practice SEP)
--	---

Pneumatic data

Power supply (inlet air)	
• Pressure	1.4 ... 7 bar (20.3 ... 101.5 psi): Sufficiently greater than max. drive pressure (actuating pressure)
Air quality to ISO 8573-1	
• Solid particle size and density	Class 2
• Pressure dew point	Class 2 (min. 20 K (36 °F) below ambient temperature)
• Oil content	Class 2
Unthrottled flow	
• Inlet air valve (ventilate actuator) ⁴⁾	
- 2 bar (29 psi)	4.1 Nm ³ /h (18.1 USgpm)
- 4 bar (58 psi)	7.1 Nm ³ /h (31.3 USgpm)
- 6 bar (87 psi)	9.8 Nm ³ /h (43.1 USgpm)
• Outlet air valve (ventilate actuator) ⁴⁾	
- 2 bar (29 psi)	8.2 Nm ³ /h (36.1 USgpm)
- 4 bar (58 psi)	13.7 Nm ³ /h (60.3 USgpm)
- 6 bar (87 psi)	19.2 Nm ³ /h (84.5 USgpm)
Valve leakage	< 6·10 ⁻⁴ Nm ³ /h (0.0026 USgpm)
Throttle ratio	Adjustable up to ∞ : 1
Power consumption in the controlled state	< 3.6·10 ⁻² Nm ³ /h (0.158 USgpm)
Types of actuators	
• In plastic casing	Single-action and double-action
• In aluminium casing	Single-action
• In flameproof casing	Single-action and double-action
• In stainless steel casing	Single-action and double-action

¹⁾ Impact energy max. 1 Joule for plastic/aluminium casing.
²⁾ During commissioning at ≤ 0 °C (≤ 32 °F) make sure that the valves are flushed long enough with the dry medium.
³⁾ At ≤ -10 °C (14 °F) the display refresh rate of the LCD is limited. Only T4 is permissible when using I_y module.
⁴⁾ With EEx d version (6DR5..5-...) the values are reduced by approx. 20%

Technical specifications

SIPART PS2	Basic device without Ex protection	Basic device with EEx-d protection (flameproof casing)	Basic device with EEx ia/ib protection	Basic device with EEx n protection
Explosion protection to EN 50014, EN 50020 and EN 50021	Without	EEx d II 2 G EEx d II C T6	EEx ia/ib II 2 G EEx ia/ib II C T6	EEx n II 3 G EEx nA L [L] II C T6
Mounting location		Zone 1	Zone 1	Zone 2
Permissible ambient temperature for operation	-30 ... +80 °C (-22 ... +176 °F)		T4: -30 ... +80 °C (-22 ... +176 °F) T5: -30 ... +65 °C (-22 ... +149 °F) T6: -30 ... +50 °C (-22 ... +122 °F)	
At ≤ -10 °C (+14 °F) the display refresh rate of the LCD is limited. (for basic devices with EEx ia/ib and EEx n protection the following applies: Only T4 is permissible when using I _y module.)				

Electrical data

Input

2-wire connection (terminals 6/8)

Rated signal range	4 ... 20 mA	4 ... 20 mA	4 ... 20 mA	4 ... 20 mA
Current to maintain the power supply	≥ 3.6 mA	≥ 3.6 mA	≥ 3.6 mA	≥ 3.6 mA
Required load voltage U _B (corresponds to Ω at 20 mA)				
• Without HART (6DR50..)				
- Typical	6.36 V (corresponds to 318 Ω)	6.36 V (corresponds to 318 Ω)	7.8 V (corresponds to 390 Ω)	7.8 V (corresponds to 390 Ω)
- Max.	6.48 V (corresponds to 324 Ω)	6.48 V (corresponds to 324 Ω)	8.3 V (corresponds to 415 Ω)	8.3 V (corresponds to 415 Ω)
• Without HART (6DR53..)				
- Typical	7.9 V (corresponds to 395 Ω)	–	–	–
- Max.	8.4 V (corresponds to 420 Ω)	–	–	–
• With HART (6DR51..)				
- Typical	6.6 V (corresponds to 330 Ω)	6.6 V (corresponds to 330 Ω)	–	–
- Max.	6.72 V (corresponds to 336 Ω)	6.72 V (corresponds to 336 Ω)	–	–
• With HART (6DR52..)				
- Typical	–	8.4 V (corresponds to 420 Ω)	8.4 V (corresponds to 420 Ω)	8.4 V (corresponds to 420 Ω)
- Max.	–	8.8 V (corresponds to 440 Ω)	8.8 V (corresponds to 440 Ω)	8.8 V (corresponds to 440 Ω)
• Static destruction limit	± 40 mA		–	–
Internal capacitance C _i				
• Without HART	–	–	≤ 22 nF	–
• With HART	–	–	≤ 7 nF	–
Internal inductance L _i				
• Without HART	–	–	≤ 0.12 mH	–
• With HART	–	–	≤ 0.24 mH	–
For connection to power circuits with	–	–	intrinsically safe U _o ≤ 30 V DC I _k ≤ 100 mA P ≤ 1 W	U _i ≤ 30 V DC I _i ≤ 100 mA

SIPART PS2	Basic device without Ex protection	Basic device with EEx-d protection (flameproof casing)	Basic device with EEx ia/ib protection	Basic device with EEx n protection
3-/4-wire device (terminals 2/4 and 6/8) (6DR52.. and 6DR53..)				
<ul style="list-style-type: none"> Power supply U_H Current consumption I_H Internal capacitance C_i Internal inductance L_i For connection to power circuits with 	18 ... 35 V DC ($U_H - 7.5$ V)/2.4 k Ω [mA]	18 ... 35 V DC ($U_H - 7.5$ V)/2.4 k Ω [mA]	18 ... 30 V DC ($U_H - 7.5$ V)/2.4 k Ω [mA] ≤ 22 nF ≤ 0.12 mH intrinsically safe $U_o \leq 30$ V DC $I_k \leq 100$ mA $P \leq 1$ W	18 ... 30 V DC ($U_H - 7.5$ V)/2.4 k Ω [mA] – – $U_i \leq 30$ V DC $I_i \leq 100$ mA
Current input I_W				
Rated signal range	0/4 ... 20 mA	0/4 ... 20 mA	0/4 ... 20 mA	0/4 ... 20 mA
Load voltage at 20 mA	≤ 0.2 V (corresponds to 10 Ω)	≤ 0.2 V (corresponds to 10 Ω)	≤ 1 V (corresponds to 50 Ω)	≤ 1 V (corresponds to 50 Ω)
Internal capacitance C_i	–	–	≤ 22 nF	–
Internal inductance (L_i)	–	–	≤ 0.12 mH	–
For connection to power circuits with	–	–	intrinsically safe $U_o \leq 30$ V DC $I_k \leq 100$ mA $P \leq 1$ W	$U_i \leq 30$ V DC $I_i \leq 100$ mA
Electrical isolation	between U_H and I_W	between U_H and I_W	between U_H and I_W (2 intrinsically safe circuits)	between U_H and I_W
Test voltage	840 V DC (1 s)	840 V DC (1 s)	840 V DC (1 s)	840 V DC (1 s)
Connections				
<ul style="list-style-type: none"> Electric 	Screw terminals 2.5 AWG28-12 Cable gland M20 x 1.5 or 1/2-14 NPT	Screw terminals 2.5 AWG28-12 EEx d certified cable gland M20 x 1.5, 1/2-14 NPT or M25 x 1.5	Screw terminals 2.5 AWG28-12 Cable gland M20 x 1.5 or 1/2-14 NPT	Screw terminals 2.5 AWG28-12 Cable gland M20 x 1.5 or 1/2-14 NPT
<ul style="list-style-type: none"> Pneumatic 	Female thread G1/4 DIN 45141 or 1/4-18 NPT	Female thread G1/4 DIN 45141 or 1/4-18 NPT	Female thread G1/4 DIN 45141 or 1/4-18 NPT	Female thread G1/4 DIN 45141 or 1/4-18 NPT
External position sensor (potentiometer or NCS; as option)				
<ul style="list-style-type: none"> U_o I_o I_s P_o 	–	–	< 5 V < 75 mA < 160 mA < 120 mW	< 5 V < 75 mA < 160 mA < 120 mW
Maximum permissible external capacitance C_o	–	–	< 1 μ F	< 1 μ F
Maximum permissible external inductance L_o	–	–	< 1 mH	< 1 mH

Technical specifications

Option modules	Without Ex protection (EEx d also)	With Ex protection EEx ia/ib	With Ex protection EEx n
Ex protection to EN 50014, EN 50020 and EN 50021	–	II 2G EEx ia/ib II C T4/T5/T6	II 3G EEx nA L [L] II C T6
Mounting location	–	Zone 1	Zone 2
Permissible ambient temperature for operation (For devices with Ex protection: Only in conjunction with the basic device 6DR5...-E..... Only T4 is permissible when using I _y module)	-30 ... +80 °C (-22 ... +176 °F)	T4: -30 ... +80 °C (-22 ... +176 °F) ¹⁾ T5: -30 ... +65 °C (-22 ... +149 °F) ¹⁾ T6: -30 ... +50 °C (-22 ... +122 °F) ¹⁾	
Alarm module	6DR4004-8A (without Ex protection)	6DR4004-6A (with Ex protection)	6DR4004-6A (with Ex protection)
Binary alarm outputs A1, A2 and alarm output			
Signal status High (not responded)	Active, R = 1 kΩ, +3/-1%*	≥ 2.1 mA	≥ 2.1 mA
Signal status Low* (responded) (* Low is also the status when the basic device is faulty or has not electric power supply)	Disabled, I _H < 60 μA (* When used in the flameproof casing the current consumption is limited to 10 mA per output.)	≤ 1.2 mA (Switching threshold with supply to EN 60947-5-6: U _H = 8.2 V, R _i = 1kΩ)	≤ 1.2 mA (Switching threshold with supply to EN 60947-5-6: U _H = 8.2 V, R _i = 1kΩ)
Internal capacitance C _i	–	≤ 5.2 nF	–
Internal inductance L _i	–	Negligible	–
Power supply U _H	≤ 35 V	–	–
Connection to power circuits with	–	intrinsically safe switching amplifier EN 60947-5-6 U _o ≤ 15.5 V DC I _k ≤ 25 mA, P ≤ 64 mW	U _i ≤ 15.5 V DC
Binary input BE2			
• Electrically connected to the basic device			
- Signal status 0	Floating contact, open	Floating contact, open	Floating contact, open
- Signal status 1	Floating contact, closed	Floating contact, closed	Floating contact, closed
- Contact load	3 V, 5 μA	3 V, 5 μA	3 V, 5 μA
• Electrically isolated from the basic device			
- Signal status 0	≤ 4.5 V or open	≤ 4.5 V or open	≤ 4.5 V or open
- Signal status 1	≥ 13 V	≥ 13 V	≥ 13 V
- Natural resistance	≥ 25 kΩ	≥ 25 kΩ	≥ 25 kΩ
Static destruction limit	± 35 V	–	–
Internal inductance and capacitance	–	Negligible	–
Connection to power circuits	–	Intrinsically safe U _i ≤ 25.2 V	U _i ≤ 25.2 V DC
Electrical isolation	The 3 outputs, the input BE2 and the basic device are electrically isolated from each other		
Test voltage	840 V DC, 1 s	840 V DC, 1 s	840 V DC, 1 s
SIA module (not for EEx d version)	6DR4004-8G (without Ex protection)	6DR4004-6G (with Ex protection)	6DR4004-6G (with Ex protection)
Limit transmitter with slot-type initiators and alarm output	2-wire connection		
Ex protection	Without	II 2 G EEx ia/ib IIC T6	II 3 G EEx nA L [L] IIC T6
Connection	2-wire system to EN 60947-5-6 (NAMUR), for switching amplifier to be connected on load side		
2 slot-type initiators	Type SJ2-SN	Type SJ2-SN	Type SJ2-SN
Function	NC (normally closed)	NC (normally closed)	NC (normally closed)
Connection to power circuits with	nominal voltage 8 V Current consumption: ≥ 3 mA (limit value not responded) ≤ 1 mA (limit value responded)	Intrinsically safe switching amplifier EN 60947-5-6 U _i ≤ 15.5 V DC I _i ≤ 25 mA, P _i ≤ 64 mW	U _i ≤ 15.5 V DC P _i ≤ 64 mW
Internal capacitance	–	≤ 41 nF	–
Internal inductance	–	≤ 100 mH	–
Electrical isolation	The 3 outputs are electrically isolated from the basic device		
Test voltage	840 V DC, 1 s	840 V DC, 1 s	840 V DC, 1 s
Alarm output	See Alarm module	See Alarm module	See Alarm module

¹⁾ Only in conjunction with the basic device 6DR5...-E..... With I_y module only T4 permitted.

Accessory modules	Without Ex protection (EEx d also)	With Ex protection EEx ia/ib	With Ex protection EEx n
Limit value contact module Limit transmitter with mechanical ground contact and alarm output Ex protection Max. switching current AC/DC Max. switching voltage AC/DC Internal capacitance C_i Internal inductance L_i Electrical isolation Test voltage Alarm module	6DR4004-8K without 4 A 250 V / 24 V – – 3150 V DC, 2s See Alarm module	6DR4004-6K II 2 G EEx ia/ib IIC T6 Connection to intrinsically safe power circuits: $U_o \leq 30$ V $I_k \leq 100$ mA, $P_i \leq 750$ mW 30 V DC Negligible Negligible 3150 V DC, 2 s See Alarm module	6DR4004-6K II 3 G EEx nA L [L] IIC T6 Connection to intrinsically safe power circuits: $U_o \leq 30$ V $I_k \leq 100$ mA, $P_i \leq 750$ mW 30 V DC – – 3150 V DC, 2 s See Alarm module
I_y module DC output for position feedback Nominal signal range i Total operating range Power supply U_H External load R_B [kW] Transmission error Temperature effect Resolution Residual ripple Internal capacitance C_i Internal inductance L_i For connection to power circuits with Electrical isolation Test voltage	6DR4004-8J (without Ex protection) 2-wire connection 4 ... 20 mA, short-circuit-proof 3.6 ... 20.5 mA +12 ... +35 V $\leq (U_H [V] - 12 V) / i [mA]$ $\leq 0.3\%$ $\leq 0.1\%/10$ K ($\leq 0.1\%/18$ °F) $\leq 0.1\%$ $\leq 1\%$ – – Electrically isolated from the basic device 840 V DC, 1 s	6DR4004-6J (with Ex protection) 2-wire connection 4 ... 20 mA, short-circuit-proof 3.6 ... 20.5 mA +12 ... +30 V $\leq (U_H [V] - 12 V) / i [mA]$ $\leq 0.3\%$ $\leq 0.1\%/10$ K ($\leq 0.1\%/18$ °F) $\leq 0.1\%$ $\leq 1\%$ ≤ 11 nF Negligible Intrinsically safe: $U_i \leq 30$ V DC $I_i \leq 100$ mA; $P_i \leq 1$ W (only T4) Electrically isolated from the basic device 840 V DC, 1 s	6DR4004-6J (with Ex protection) 2-wire connection 4 ... 20 mA, short-circuit-proof 3.6 ... 20.5 mA +12 ... +30 V $\leq (U_H [V] - 12 V) / i [mA]$ $\leq 0.3\%$ $\leq 0.1\%/10$ K ($\leq 0.1\%/18$ °F) $\leq 0.1\%$ $\leq 1\%$ – – Electrically isolated from the basic device 840 V DC, 1 s
NCS sensor (not for EEx d version) Position range • Linear actuator • Part-turn actuator Linearity (after correction by SIPART PS2) • Linear actuator • Part-turn actuator Hysteresis Continuous working temperature Degree of protection of casing	3 ... 130 mm (0.12 ... 5.12 inch), to 200 mm (7.87 inch) on request 30° ... 100° $\pm 1\%$ $\pm 1\%$ $\pm 0.2\%$ -40 ... +85 °C (-40 ... +185 °F), extended temperature range on request IP68/NEMA 4X	3 ... 130 mm (0.12 ... 5.12 inch), to 200 mm (7.87 inch) on request 30° ... 100° $\pm 1\%$ $\pm 1\%$ $\pm 0.2\%$ -40 ... +85 °C (-40 ... +185 °F), extended temperature range on request IP68/NEMA 4X	3 ... 130 mm (0.12 ... 5.12 inch), to 200 mm (7.87 inch) on request 30° ... 100° $\pm 1\%$ $\pm 1\%$ $\pm 0.2\%$ -40 ... +85 °C (-40 ... +185 °F), extended temperature range on request IP68/NEMA 4X

Scope of Delivery

7

The positioner and its options modules are delivered as separate units and in different versions. Positioners and options modules for operation in hazardous areas and non-hazardous areas are available. These versions are identified respectively by a special rating plate.

www.DataSheet4U.com



WARNING

In the combination of components it must be ensured that only positioners and options modules are combined which are approved for the respective area of application. This applies especially for safe operation of the positioner in areas in which the atmosphere is potentially explosive (zone 1 and 2). The instrument categories (2 and 3) of the instrument itself and those of its options must be observed.

7.1 Scope of delivery of standard controller

Versions	Housing	Valve	Ex-protection	Order numbers
SIPART PS2 2L without HART	Plastic housing	single action	non Ex	6DR5010-xNxxx-0AA0
	Plastic housing	double action	non Ex	6DR5020-xNxxx-0AA0
	Metal housing	single action	non Ex	6DR5011-xNxxx-0AA0
SIPART PS2 2L without HART	Plastic housing	single action	CENELEC/FM	6DR5010-xExxx-0AA0
	Plastic housing	double action	CENELEC/FM	6DR5020-xExxx-0AA0
	Metal housing	single action	CENELEC/FM	6DR5011-xExxx-0AA0
	Explosion proof housing	single action	CENELEC/FM	6DR5015-xExxx-0AA0
	Explosion proof housing	double action	CENELEC/FM	6DR5025-xExxx-0AA0
SIPART PS2 2L with HART	Plastic housing	single action	non Ex	6DR5110-xNxxx-0AA0
	Plastic housing	double action	non Ex	6DR5120-xNxxx-0AA0
	Metal housing	single action	non Ex	6DR5111-xNxxx-0AA0
SIPART PS2 4L with HART	Plastic housing	single action	CENELEC/FM	6DR5210-xExxx-0AA0
	Plastic housing	double action	CENELEC/FM	6DR5220-xExxx-0AA0
	Metal housing	single action	CENELEC/FM	6DR5211-xExxx-0AA0
	Explosion proof housing	single action	CENELEC/FM	6DR5215-xExxx-0AA0
	Explosion proof housing	double action	CENELEC/FM	6DR5225-xExxx-0AA0
SIPART PS2 4L without HART	Plastic housing	single action	non Ex	6DR5310-xNxxx-0AA0
	Plastic housing	double action	non Ex	6DR5320-xNxxx-0AA0
	Metal housing	single action	non Ex	6DR5311-xNxxx-0AA0

2L corresponds to two-wire operation

4L corresponds to four-wire-operation

-x stands for sub-variant

7.2 Scope of delivery of options

Option	Order number
I _y - module without protection against explosion	6DR4004-8J
I _y - module with protection against explosion PTB ¹⁾	6DR4004-6J
I _y - module with protection against explosion FM ²⁾	6DR4004-7J
Alarm unit without protection against explosion	6DR4004-8A
Alarm unit with protection against explosion PTB ¹⁾	6DR4004-6A
Alarm unit with protection against explosion FM ²⁾	6DR4004-7A
SIA-module without protection against explosion	6DR4004-8G
SIA-module with protection against explosion CENELEC and FM ¹⁾²⁾	6DR4004-6G
Limit-contact module without protection against explosion	6DR4004-8K
Limit-switch module with protection against explosion CENELEC and FM ¹⁾²⁾³⁾	6DR4004-6K

1) EC-type examination certificate





2) Approval Reports from Factory Mutual System

3) In preparation

7.3 Scope of delivery of accessories

Accessories	Order number
Mounting kit set linear actuators IEC 534 – 6 including lever arm for 3 to 35 mm way	6DR4004-8V
Additional lever for > 35 to 130 mm way	6DR4004-8L
Mounting kit part-turn actuators VDI/VDE 3845	6DR4004-8D
Solenoid valve block for SAMSON actuator (integrated mounting)	6DR4004-1C
Manometer block single acting	6DR4004-1M
Manometer block double acting	6DR4004-2M
Solenoid valve block single acting (NAMUR)	6DR4004-1B
Mounting set for SAMSON actuator (integrated mounting)	6DR4004-8S
NCS-Sensor not explosion protected explosion-protected cable length 6 m for part-turn actuators for linear actuators up to 14 mm	6DR4004-__N__0 6DR4004-8N 6DR4004-6N 6DR4004-__NN 6DR4004-__N_10 6DR4004-__N_20
EMC filter module	C73451-A430-D23
External position detection system	C73451-A430-D78
Operating software SIMATIC PDM	on request

7.4 List of Spare Parts

Spare parts list: SIPART PS2 positioner			
	Description	Order No.	for version
	Cover (plastic enclosure) with screws (4 pcs) and seal	C73451-A430-D82	6DR4 ___ 6DR5 ___
	Cover (metal enclosure) with screws (4 pcs) and seal	C73451-A430-D83	6DR4 ___ 6DR5 ___
	Motherboard, two-wire without HART, without explosion protection	A5E00082459	6DR50 __ - N 6DR40 __ - N *)
	Motherboard, two-wire without HART, with explosion protection	A5E00082457	6DR50 __ - E
	Motherboard, two-wire HART, without explosion protection	A5E00082458	6DR51 __ - N 6DR40 __ - N *)
	Motherboard, two-,three-,four-wire HART, with explosion protection	A5E00082456	6DR52 __
	Motherboard Two-,three-,four-wire without HART, without expl. protect.	A5E00102018	6DR53 __ - N 6DR40 __ - N *)
	Motherboard PROFIBUS PA, without explosion protection	A5E00141523	6DR55 __ - N. 6DR41 __ - N
	Motherboard PROFIBUS PA, with explosion protection	A5E00141550	6DR55 __ - E 6DR41 __ - E
	Motherboard FIELDBUS Foundation, without explosion proof	A5E00215467	6DR56 __
	Motherboard FIELDBUS Foundation, with explosion protection	A5E00215466	6DR56 __
	Pneumatic block (Valve single acting incl. seals and screws)	C73451-A430-D80	6DR4 ___ 6DR5 ___
	Pneumatic block (Valve double acting incl. seals and screws)	C73451-A430-D81	6DR4 ___ 6DR5 ___
	Potentiometer (complete)	C73451-A430-D84	6DR4 ___ 6DR5 ___

*) 6DR40.. can be used after having clarified whether application with two-wire or three-wire/four-wire input

Note: For accessories and option modules see Catalog FI 01 "Field Instruments for Process Automation"

A

Accessories, 39
Actuating ranges, 130
Alarm function, 106
Alarm module, 32, 61, 66, 70
Application
 positioner in a wet environment, 44
 under great accelerations and vibrations, 46
Assembly, 43
 Screw-type gland with plastic hose, 46
Assembly procedure, 50, 53
 linear actuator, 51
 part-turn actuator, 54, 55
Automatic, Changing the operating mode, 94

B

Base plate, 58
Block diagram, Mode of operation, 25

C

Catalogs, 159
Commissioning, 72
Configuration, changing the operating mode, 93
Controller data, Optimization, 143
Current output, Electrical Connection, 61, 66, 69

D

Delivery, 10
Design name plate, 17
Diagnosis, 122
 Display, 122
 Online, 131
Diagnosis values, Meaning of ~, 123
Diagnostic display, Changing the operating mode, 94
Digital input, electrical connection, 61, 66, 70
Digital output, electrical connection, 61, 66, 70
Dimensional drawings, 41
Display, 89
Display text, Meaning, 139
Documentation, 9
double-acting, 13, 14

E

Electrical connection, 18, 57
EMV-filter module, 38

F

Filters, Cleaning the ~, 145
Firmware version, 91
Four-wire connection, 60, 64, 69

G

General information, 5

H

HART module, 26
Housing, 11

I

Initialization, 100
 Automatic ~, Structogram, 83
 automatic ~, 72, 74, 79, 82
 changing the operating mode, 93
 copying ~, 72
 manual ~, 72, 76, 81
Initialization data, Copying the ~, 87
Input keys, 89
Installation positions, favorable and unfavorable, 45, 47
Instrument identification, 41
ly module, 31, 61, 66, 69

L

Lever arm transmission, 99
Linear actuator, 13, 14
 automatic initialization, 74
 manual initialization, 76
 preparation, 73
Literature, 159

M

Maintenance, 145

Manometer block, 39
Manual mode
 Changing the operating mode, 94
 P manual mode, 93
Mechanical limit switch module, 35, 62
 EEx i, 67
Mechanical limit switch module, 67
 not EEx, 62
Method of operation, 15, 23
Mounting kit
 linear actuator, 49
 part-turn actuator, 52

O

Operating mode
 AUT, 94
 MAN, 94
Operating Modes, 92
Operating modes, Change ~, 92
Operation, 89
Options, 12, 27

P

Parameter table, SIPART PS2, 96
Parameters, 95
Part-turn actuator, 13, 14, 56, 57
 Automatic initialization, 79
 manual initialization, 81
 preparation, 79
PDM (Process Device Manager), 87
Personnel, Qualification, 7
Pneumatic connection, 19, 71
Positioner exchange, 72, 87
Positioning, 21
Purge air switching, 22

Q

Qualified Personnel, 7

R

Restrictors, 22

S

Scope of Delivery, 153
Series circuit, of two positioners, 65
Service, 145
Setpoint, 130
Setpoint characteristic, 102
SIA module, 33, 62, 67, 70
 Electrical Connection, 62, 67, 70
single-acting, 13, 14
Split range, 65, 100
 Electrical Connection, 65
Standard controller, 63, 68
Standards, 10
Structograms of automatic initialization, 82

T

Technical data, 147
Three-wire connection, 60, 64, 69
Two-wire connection, 59, 60, 63, 68
Type key, 41

U

Use as intended, 9

V

Versions, 11
Vibrations, 46
View of the instrument, 17

W

Warranty, 9
wet environment, 44

9.1 Literature and catalogs

www.DataSheet4U.com

Nr.	Title	Issue by	Order no.
/1/	Industrial Communication for Automation and Devices Catalog IK PI · 2005	Siemens AG	E86060-K6710-A101-B4-7600
/2/	Field Instruments for Process Automation Catalog FI 01 · 2007	Siemens AG	E86060-K6201-A101-A8-7600
/3/	SIMATIC PCS 7 Process Control System Catalog ST PCS 7 · 2005	Siemens AG	E86060-K4678-A111-A9-7600

