



6N65Z

Power MOSFET

6.2A, 650V N-CHANNEL POWER MOSFET

DESCRIPTION

The UTC **6N65Z** is a high voltage power MOSFET designed to have better characteristics, such as fast switching time, low gate charge, low on-state resistance and high rugged avalanche characteristics. This power MOSFET is usually used in high speed switching applications of switching power supplies and adaptors.

FEATURES

- * $R_{DS(ON)} = 1.85\Omega @ V_{GS} = 10V, I_D = 3.1A$
- * Fast switching capability
- * Avalanche energy tested
- * Improved dv/dt capability, high ruggedness

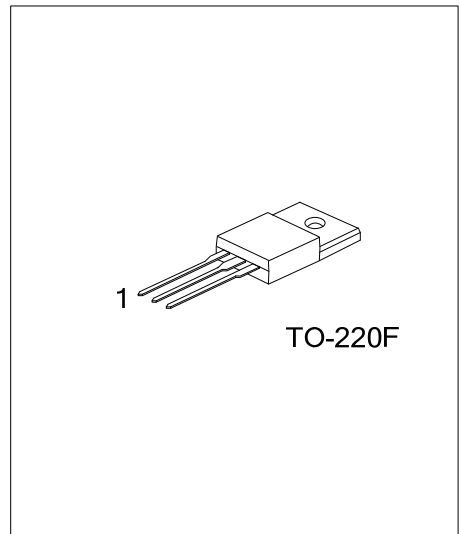

SYMBOL

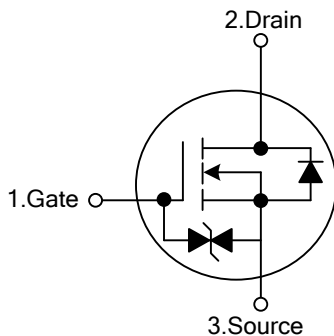

ORDERING INFORMATION

Ordering Number		Package	Pin Assignment			Packing
Lead Free	Halogen Free		1	2	3	
6N65ZL-TF3-T	6N65ZG-TF3-T	TO-220F	G	D	S	Tube

Note: Pin Assignment: G: Gate D: Drain S: Source

<p>6N65ZL-TF3-T</p> <ul style="list-style-type: none"> (1) Packing Type (2) Package Type (3) Lead Free 	<ul style="list-style-type: none"> (1) T: Tube (2) TF3: TO-220F (3) L: Lead Free, G: Halogen Free
---	--

■ ABSOLUTE MAXIMUM RATINGS ($T_C = 25^\circ\text{C}$, unless otherwise specified)

PARAMETER		SYMBOL	RATINGS	UNIT
Drain-Source Voltage		V_{DSS}	650	V
Gate-Source Voltage		V_{GSS}	± 20	V
Avalanche Current (Note 2)		I_{AR}	6.2	A
Continuous Drain Current		I_D	6.2	A
Pulsed Drain Current (Note 2)		I_{DM}	24.8	A
Avalanche Energy	Single Pulsed (Note 3)	E_{AS}	250	mJ
	Repetitive (Note 2)	E_{AR}	13	mJ
Peak Diode Recovery dv/dt (Note 4)		dv/dt	4.5	ns
Power Dissipation		P_D	40	W
Junction Temperature		T_J	+150	$^\circ\text{C}$
Operating Temperature		T_{OPR}	-55 ~ +150	$^\circ\text{C}$
Storage Temperature		T_{STG}	-55 ~ +150	$^\circ\text{C}$

Notes: 1. Absolute maximum ratings are those values beyond which the device could be permanently damaged.

Absolute maximum ratings are stress ratings only and functional device operation is not implied.

2. Repetitive Rating : Pulse width limited by T_J .

3. $L = 14\text{mH}$, $I_{AS} = 6\text{A}$, $V_{DD} = 90\text{V}$, $R_G = 25\ \Omega$, Starting $T_J = 25^\circ\text{C}$

4. $I_{SD} \leq 6.2\text{A}$, $di/dt \leq 200\text{A}/\mu\text{s}$, $V_{DD} \leq BV_{DSS}$, Starting $T_J = 25^\circ\text{C}$

■ THERMAL DATA

PARAMETER	SYMBOL	RATING	UNIT
Junction to Ambient	θ_{JA}	62.5	$^\circ\text{C}/\text{W}$
Junction to Case	θ_{JC}	3.2	$^\circ\text{C}/\text{W}$

■ ELECTRICAL CHARACTERISTICS ($T_J = 25^\circ\text{C}$, unless otherwise specified)

PARAMETER	SYMBOL	TEST CONDITIONS	MIN	TYP	MAX	UNIT
OFF CHARACTERISTICS						
Drain-Source Breakdown Voltage	BV_{DSS}	$V_{GS} = 0V, I_D = 250\mu A$	650			V
Drain-Source Leakage Current	I_{DSS}	$V_{DS} = 650V, V_{GS} = 0V$			10	μA
Gate- Source Leakage Current	Forward	I_{GSS}			5	μA
	Reverse					
		$V_{GS} = -20V, V_{DS} = 0V$			5	μA
Breakdown Voltage Temperature Coefficient	$\Delta BV_{DSS}/\Delta T_J$	$I_D = 250\mu A$, Referenced to 25°C		0.53		$V/^\circ\text{C}$
ON CHARACTERISTICS						
Gate Threshold Voltage	$V_{GS(TH)}$	$V_{DS} = V_{GS}, I_D = 250\mu A$	2.0		4.0	V
Static Drain-Source On-State Resistance	$R_{DS(ON)}$	$V_{GS} = 10V, I_D = 3.1A$		1.4	1.85	Ω
DYNAMIC CHARACTERISTICS						
Input Capacitance	C_{ISS}	$V_{DS} = 30V, V_{GS} = 0.5V,$ $f = 1.0\text{ MHz}$		840	1000	pF
Output Capacitance	C_{OSS}			80	100	pF
Reverse Transfer Capacitance	C_{RSS}			17	20	pF
SWITCHING CHARACTERISTICS						
Turn-On Delay Time	$t_{D(ON)}$	$V_{DD} = 325V, I_D = 6.2A,$ $R_G = 25\Omega$ (Note 1, 2)		40	60	ns
Turn-On Rise Time	t_R			90	150	ns
Turn-Off Delay Time	$t_{D(OFF)}$			185	210	ns
Turn-Off Fall Time	t_F			105	130	ns
Total Gate Charge	Q_G	$V_{DS} = 520V, I_D = 6.2A,$ $V_{GS} = 10V$ (Note 1, 2)		100	120	nC
Gate-Source Charge	Q_{GS}			20		nC
Gate-Drain Charge	Q_{GD}			30		nC
DRAIN-SOURCE DIODE CHARACTERISTICS AND MAXIMUM RATINGS						
Drain-Source Diode Forward Voltage	V_{SD}	$V_{GS} = 0V, I_S = 6.2A$			1.4	V
Maximum Continuous Drain-Source Diode Forward Current	I_S				6.2	A
Maximum Pulsed Drain-Source Diode Forward Current	I_{SM}				24.8	A
Reverse Recovery Time	t_{rr}	$V_{GS} = 0V, I_S = 6.2A,$ $di_F/dt = 100\text{ A}/\mu\text{s}$ (Note 1)		290		ns
Reverse Recovery Charge	Q_{RR}			2.35		μC

Notes: 1. Pulse Test: Pulse width $\leq 300\mu\text{s}$, Duty cycle $\leq 2\%$.

2. Essentially independent of operating temperature.

■ TEST CIRCUITS AND WAVEFORMS

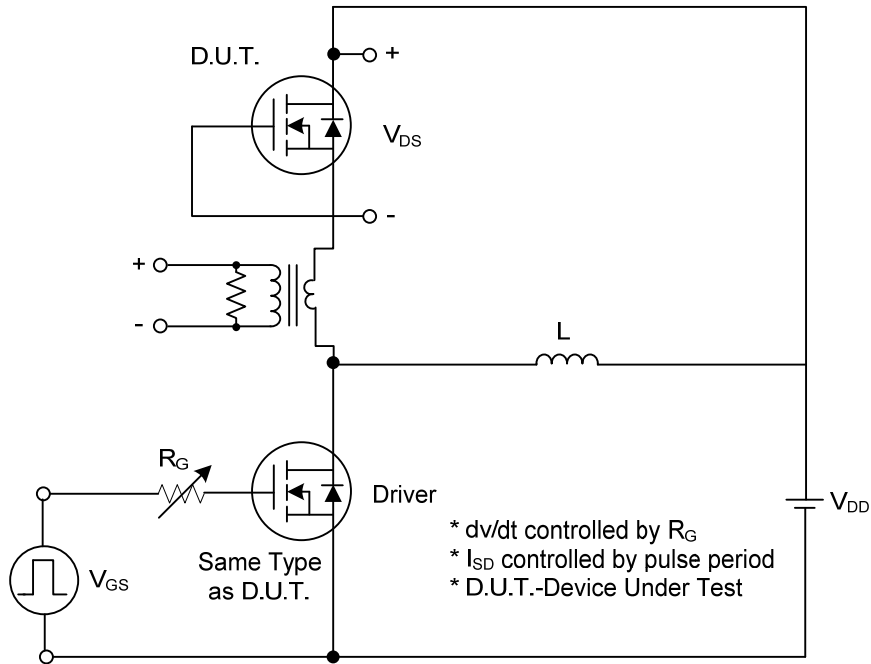

Peak Diode Recovery dv/dt Test Circuit

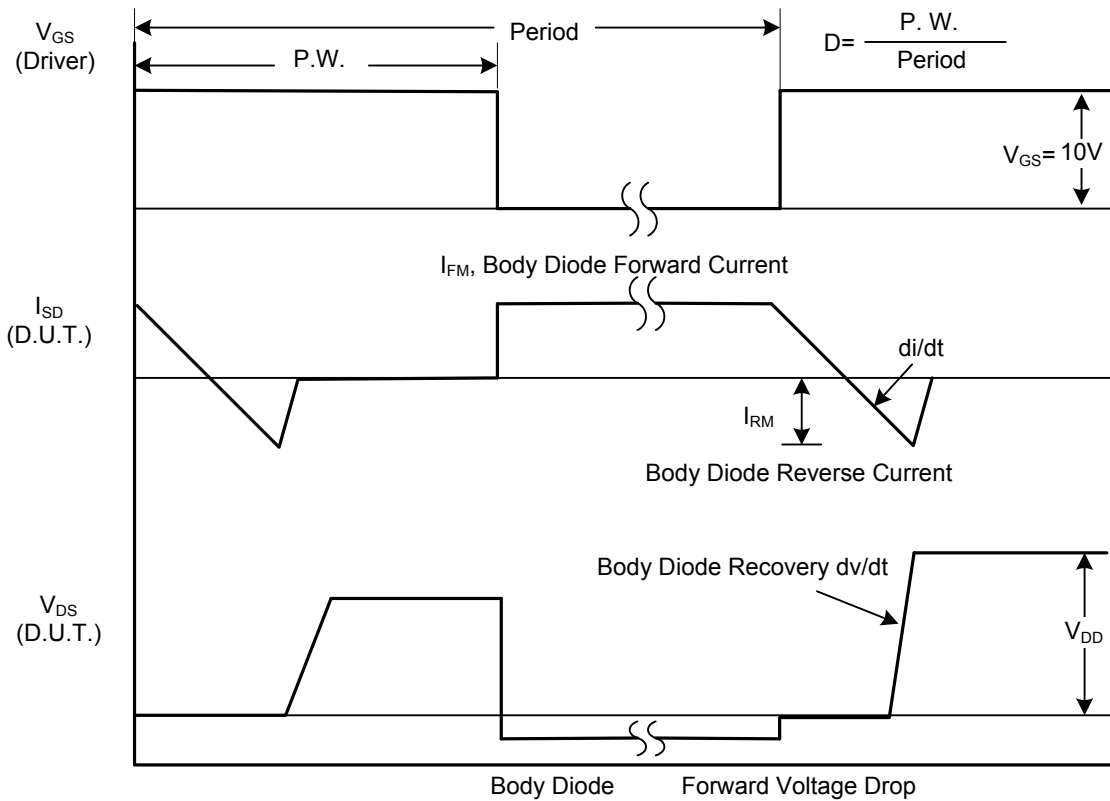

Peak Diode Recovery dv/dt Waveforms

■ TEST CIRCUITS AND WAVEFORMS

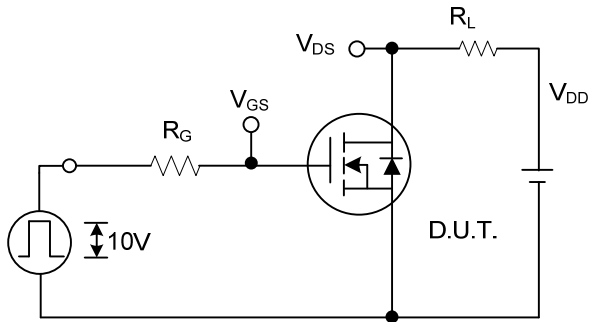

Switching Test Circuit

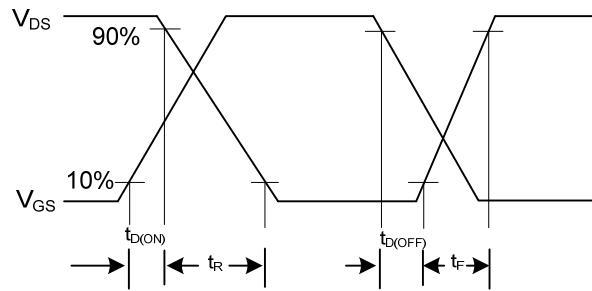

Switching Waveforms

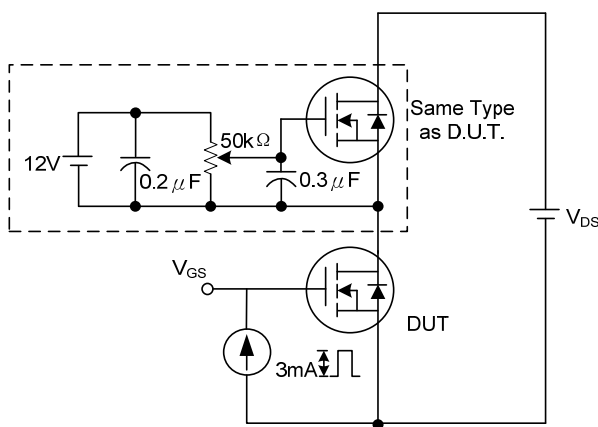

Gate Charge Test Circuit

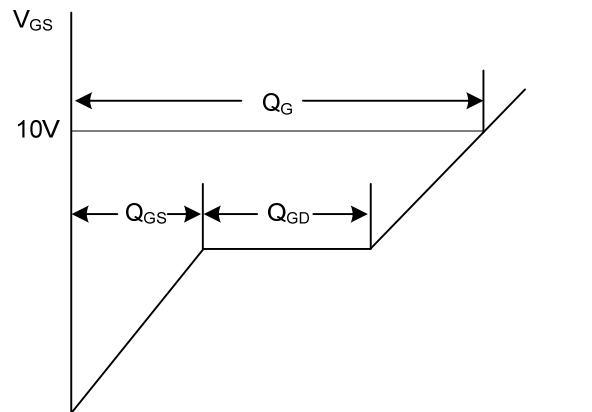

Gate Charge Waveform

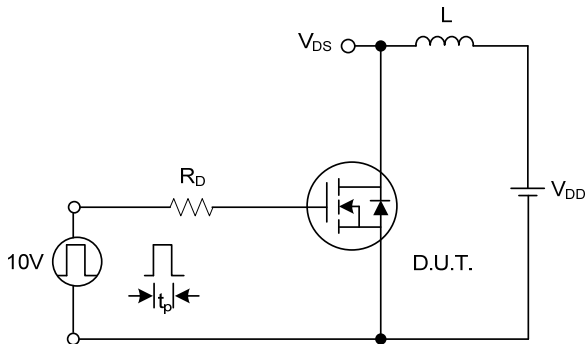

Unclamped Inductive Switching Test Circuit

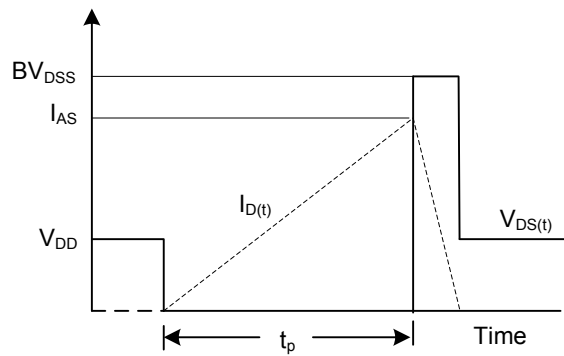

Unclamped Inductive Switching Waveforms

■ TYPICAL CHARACTERISTICS

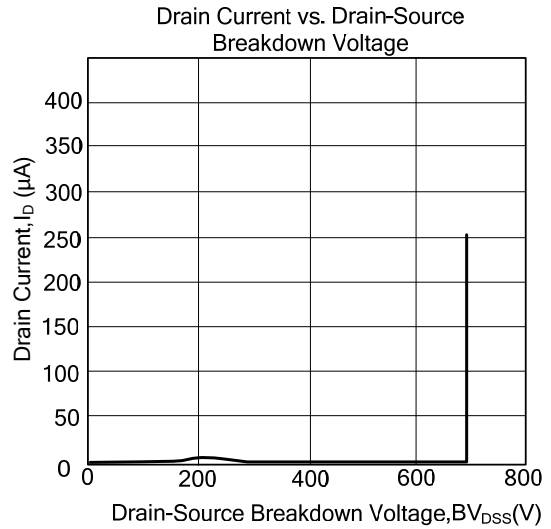
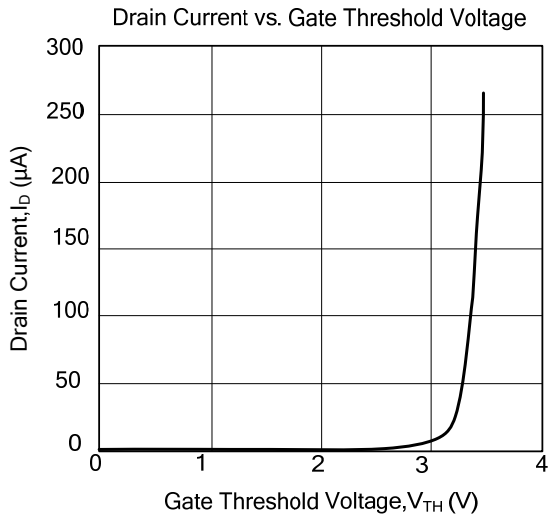
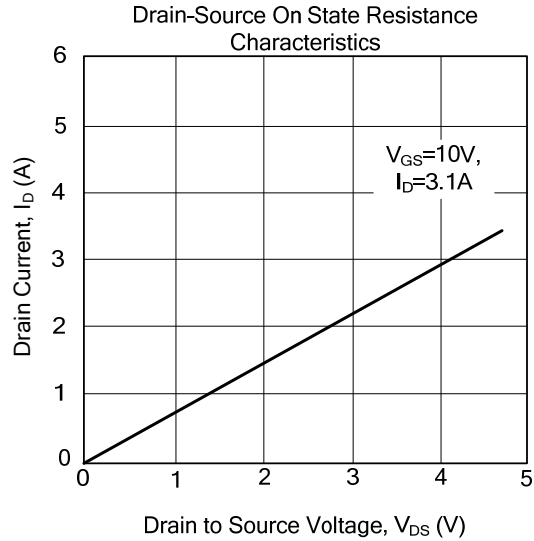
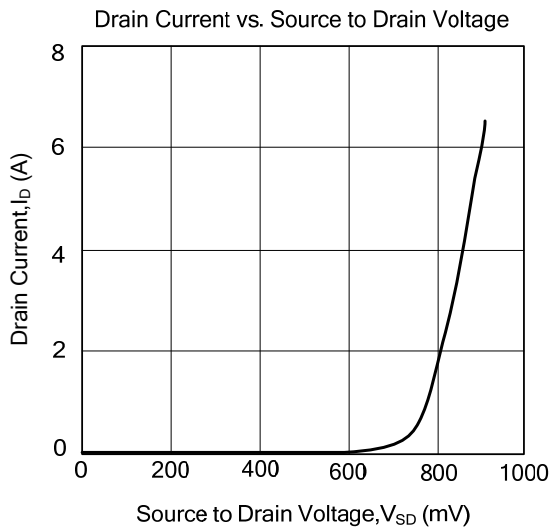

UTC assumes no responsibility for equipment failures that result from using products at values that exceed, even momentarily, rated values (such as maximum ratings, operating condition ranges, or other parameters) listed in products specifications of any and all UTC products described or contained herein. UTC products are not designed for use in life support appliances, devices or systems where malfunction of these products can be reasonably expected to result in personal injury. Reproduction in whole or in part is prohibited without the prior written consent of the copyright owner. The information presented in this document does not form part of any quotation or contract, is believed to be accurate and reliable and may be changed without notice.