



6N70K-MT

Power MOSFET

6A, 700V N-CHANNEL POWER MOSFET

■ DESCRIPTION

The UTC 6N70K-MT is an N-channel mode power MOSFET using UTC's advanced technology to provide customers with a minimum on-state resistance, high switching speed, low gate charge and low input capacitance.

The UTC 6N70K-MT is universally applied in high efficiency switch mode power supply.

■ FEATURES

* $R_{DS(ON)} \leq 1.6\Omega$ @ $V_{GS}=10V, I_D=3.0A$

* High switching speed

■ SYMBOL

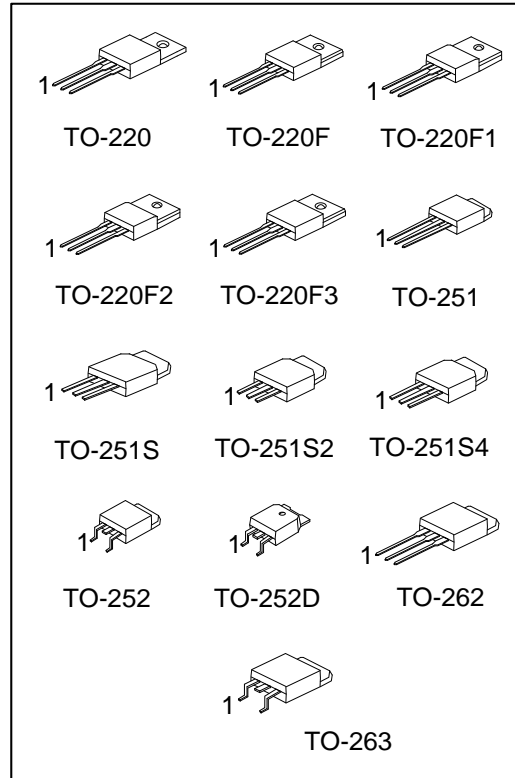
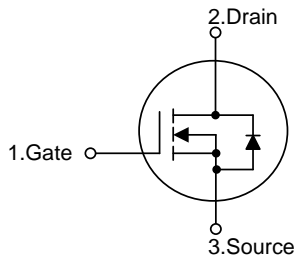

ORDERING INFORMATION

Ordering Number		Package	Pin Assignment			Packing
Lead Free	Halogen Free		1	2	3	
6N70KL-TA3-T	6N70KG-TA3-T	TO-220	G	D	S	Tube
6N70KL-TF3-T	6N70KG-TF3-T	TO-220F	G	D	S	Tube
6N70KL-TF1-T	6N70KG-TF1-T	TO-220F1	G	D	S	Tube
6N70KL-TF2-T	6N70KG-TF2-T	TO-220F2	G	D	S	Tube
6N70KL-TF3T-T	6N70KG-TF3T-T	TO-220F3	G	D	S	Tube
6N70KL-TM3-T	6N70KG-TM3-T	TO-251	G	D	S	Tube
6N70KL-TMS-T	6N70KG-TMS-T	TO-251S	G	D	S	Tube
6N70KL-TMS2-T	6N70KG-TMS2-T	TO-251S2	G	D	S	Tube
6N70KL-TMS4-T	6N70KG-TMS4-T	TO-251S4	G	D	S	Tube
6N70KL-TN3-R	6N70KG-TN3-R	TO-252	G	D	S	Tape Reel
6N70KL-TND-R	6N70KG-TND-R	TO-252D	G	D	S	Tape Reel
6N70KL-T2Q-T	6N70KG-T2Q-T	TO-262	G	D	S	Tube
6N70KL-TQ2-T	6N70KG-TQ2-T	TO-263	G	D	S	Tube
6N70KL-TQ2-R	6N70KG-TQ2-R	TO-263	G	D	S	Tape Reel

Note: Pin Assignment: G: Gate D: Drain S: Source

	<p>(1) T: Tube, R: Tape Reel (2) TA3: TO-220, TF1: TO-220F1, TF2: TO-220F2 TF3: TO-220F, TF3T: TO-220F3, TM3: TO-251, TMS: TO-251S, TMS2: TO-251S2, TN3: TO-252, TMS4: TO-251S4, TND: TO-252D, T2Q: TO-262, TQ2: TO-263 (3) G: Halogen Free and Lead Free, L: Lead Free</p>
--	---

MARKING

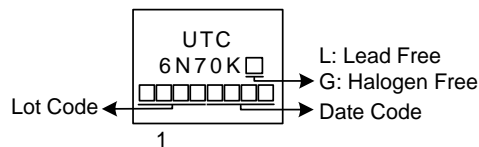

■ ABSOLUTE MAXIMUM RATINGS ($T_C=25^\circ\text{C}$, unless otherwise specified)

PARAMETER		SYMBOL	RATINGS	UNIT	
Drain-Source Voltage		V_{DSS}	700	V	
Gate-Source Voltage (Note 2)		V_{GSS}	± 30	V	
Drain Current	Continuous	I_D	$T_C=25^\circ\text{C}$	6	A
			$T_C=100^\circ\text{C}$	3.8	A
Pulsed		I_{DM}	24	A	
Avalanche Current (Note 2)		I_{AR}	6	A	
Avalanche Energy	Single Pulsed (Note 3)	E_{AS}	284	mJ	
	Repetitive (Note 2)	E_{AR}	13	mJ	
Peak Diode Recovery dv/dt (Note 4)		dv/dt	2.5	V/ns	
Power Dissipation	TO-220/TO-263	P_D	125	W	
	TO-220F		32	W	
	TO-220F1/TO-220F2		33	W	
	TO-220F3				
	TO-251/TO-251S		48	W	
	TO-251S2/TO-251S4				
TO-252/TO-252D					
TO-262		125	W		
Junction Temperature		T_J	+150	$^\circ\text{C}$	
Storage Temperature		T_{STG}	-55 ~ +150	$^\circ\text{C}$	

Notes: 1. Absolute maximum ratings are those values beyond which the device could be permanently damaged.

Absolute maximum ratings are stress ratings only and functional device operation is not implied.

2. Repetitive Rating: Pulse width limited by maximum junction temperature

3. $L = 15.77\text{mH}$, $I_{AS} = 6\text{A}$, $V_{DD} = 50\text{V}$, $R_G = 27\Omega$, Starting $T_J = 25^\circ\text{C}$

4. $I_{SD} \leq 6\text{A}$, $di/dt \leq 140\text{A}/\mu\text{s}$, $V_{DD} \leq BV_{DSS}$, Starting $T_J = 25^\circ\text{C}$

■ THERMAL DATA

PARAMETER		SYMBOL	RATINGS	UNIT
Junction to Ambient	TO-220/TO-220F TO-220F1/TO-220F2 TO-220F3/TO-262 TO-263	θ_{JA}	62.5	$^\circ\text{C}/\text{W}$
	TO-251/TO-251S TO-251S2/TO-251S4 TO-252/TO-252D		110	$^\circ\text{C}/\text{W}$
Junction to Case	TO-220	θ_{JC}	1	$^\circ\text{C}/\text{W}$
	TO-220F		3.9	$^\circ\text{C}/\text{W}$
	TO-220F1/TO-220F2 TO-220F3		3.78	$^\circ\text{C}/\text{W}$
	TO-251/TO-251S TO-251S2/TO-251S4 TO-252/TO-252D		2.6 (Note)	$^\circ\text{C}/\text{W}$
	TO-262		1	$^\circ\text{C}/\text{W}$

Note: Device mounted on FR-4 substrate PC board, 2oz copper, with 1inch square copper plate.

■ ELECTRICAL CHARACTERISTICS (T_C=25°C, unless otherwise specified)

PARAMETER	SYMBOL	TEST CONDITIONS	MIN	TYP	MAX	UNIT
OFF CHARACTERISTICS						
Drain-Source Breakdown Voltage	BV _{DSS}	I _D =250μA, V _{GS} =0V	700			V
Breakdown Voltage Temperature Coefficient	ΔBV _{DSS} /ΔT _J	I _D =250μA		0.79		V/°C
Drain-Source Leakage Current	I _{DSS}	V _{DS} =700V			25	μA
		V _{DS} =560V, T _C =125°C			250	μA
Gate-Source Leakage Current	Forward	V _{GS} =+30V, V _{DS} =0V			+100	nA
	Reverse	V _{GS} =-30V, V _{DS} =0V			-100	nA
ON CHARACTERISTICS						
Gate Threshold Voltage	V _{GS(TH)}	V _{DS} =V _{GS} , I _D =250μA	2.0		4.0	V
Static Drain-Source On-State Resistance	R _{DS(ON)}	V _{GS} =10V, I _D =3.0A (Note 1)		1.35	1.6	Ω
DYNAMIC PARAMETERS						
Input Capacitance	C _{ISS}	V _{GS} =0V, V _{DS} =25V, f=1.0MHz (Note 1, 2)		480	600	pF
Output Capacitance	C _{OSS}			80	100	pF
Reverse Transfer Capacitance	C _{RSS}			6.5	25	pF
SWITCHING PARAMETERS						
Total Gate Charge	Q _G	V _{DS} =50V, V _{GS} =10V, I _D =1.3A I _G =100μA (Note 1, 2)		21.8	32	nC
Gate to Source Charge	Q _{GS}			6.8		nC
Gate to Drain Charge	Q _{GD}			4.8		nC
Turn-ON Delay Time	t _{D(ON)}	V _{DD} =30V, V _{GS} =10V, I _D =0.5A, R _G =25Ω (Note 1, 2)		57	80	ns
Rise Time	t _R			60	85	ns
Turn-OFF Delay Time	t _{D(OFF)}			130	140	ns
Fall-Time	t _F			54	60	ns
SOURCE- DRAIN DIODE RATINGS AND CHARACTERISTICS						
Maximum Body-Diode Continuous Current	I _S	Integral reverse pn-diode in the MOSFET			6	A
Maximum Body-Diode Pulsed Current (Note 3)	I _{SM}				24	A
Drain-Source Diode Forward Voltage (Note 2)	V _{SD}	I _S =6A, V _{GS} =0V, T _J = 25°C			1.4	V
Reverse Recovery Time	t _{rr}	I _S =6A, V _{DD} =100V		480		ns
Reverse Recovery Charge	Q _{rr}	di/dt = 100A/μs		3.5		μC

Notes: 1. Pulse Test: Pulse width ≤ 250μs, Duty cycle ≤ 2%.

2. Essentially independent of operating temperature.

TEST CIRCUITS AND WAVEFORMS

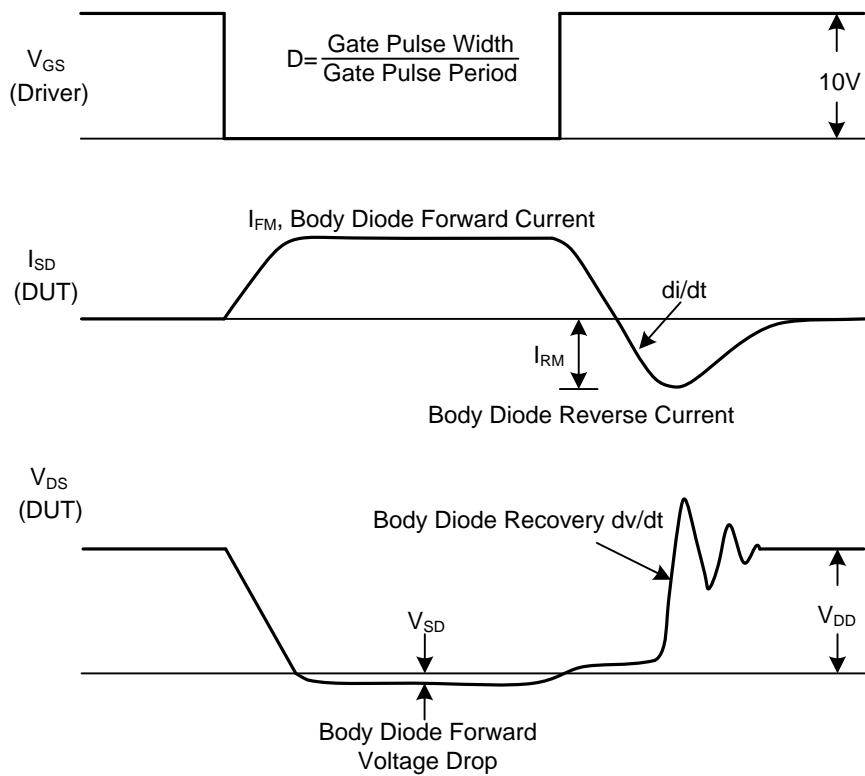
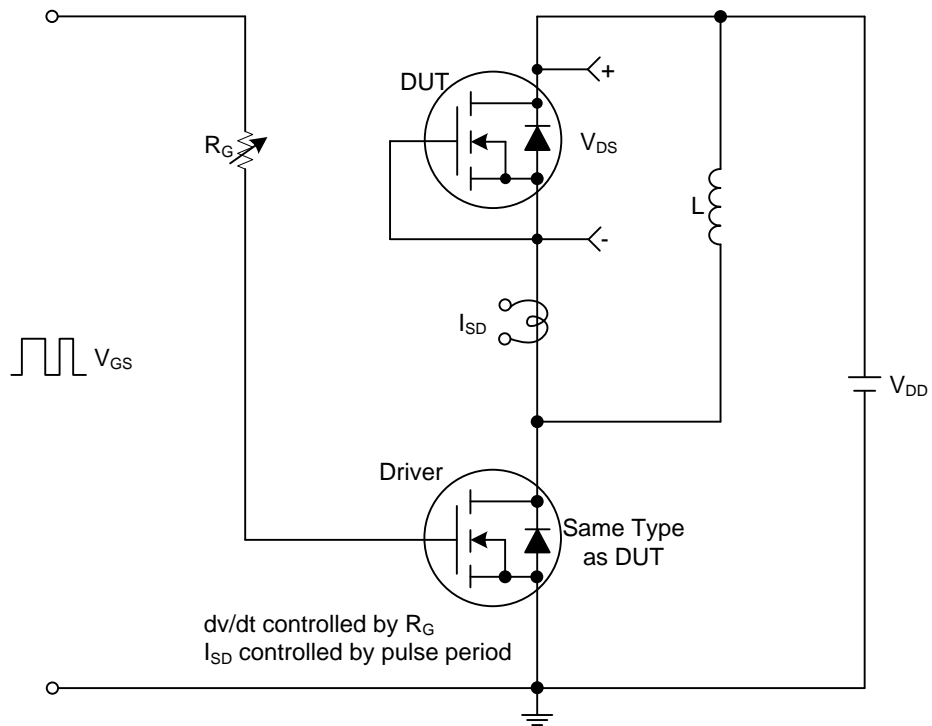

Peak Diode Recovery dv/dt Test Circuit and Waveforms

TEST CIRCUITS AND WAVEFORMS

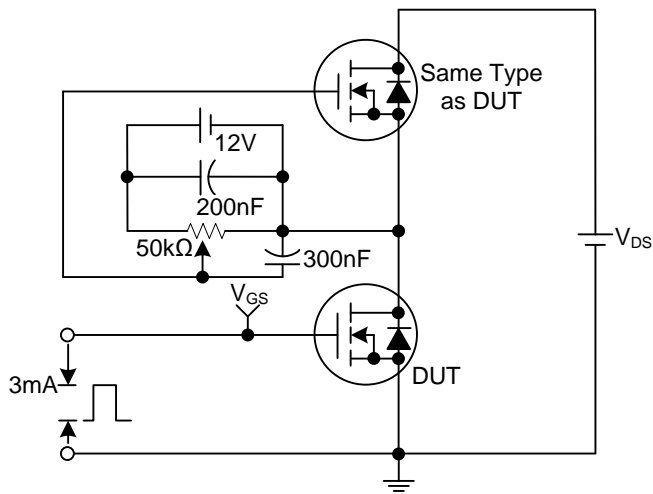

Gate Charge Test Circuit

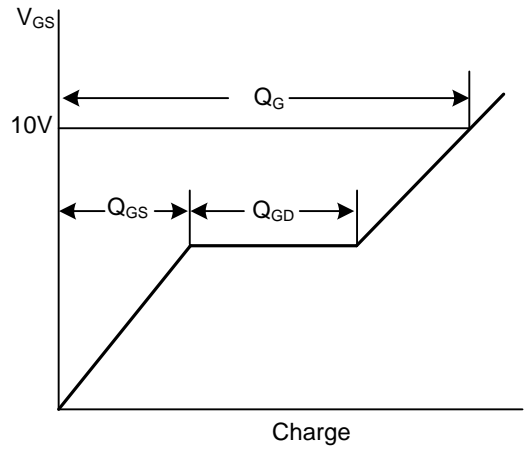

Gate Charge Waveforms

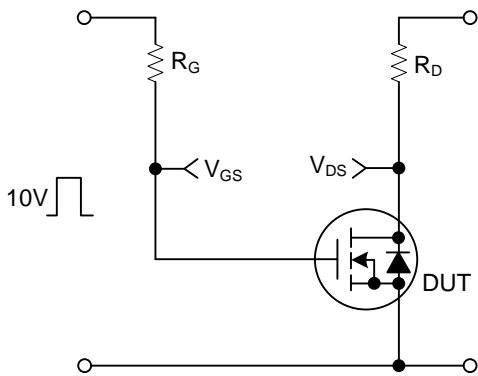

Resistive Switching Test Circuit

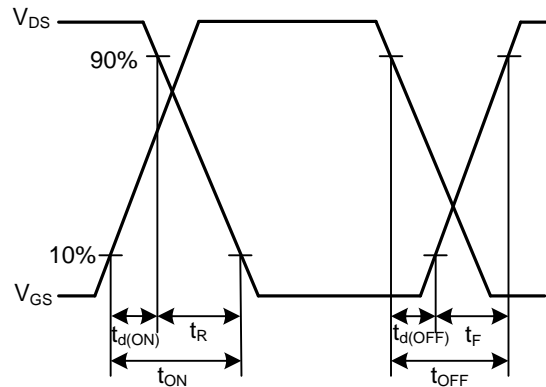

Resistive Switching Waveforms

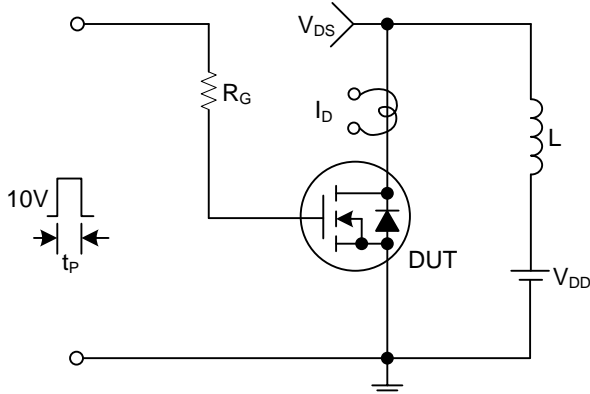

Unclamped Inductive Switching Test Circuit

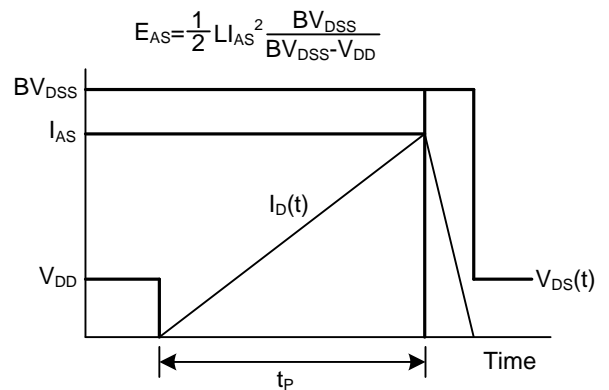

Unclamped Inductive Switching Waveforms

■ TYPICAL CHARACTERISTICS

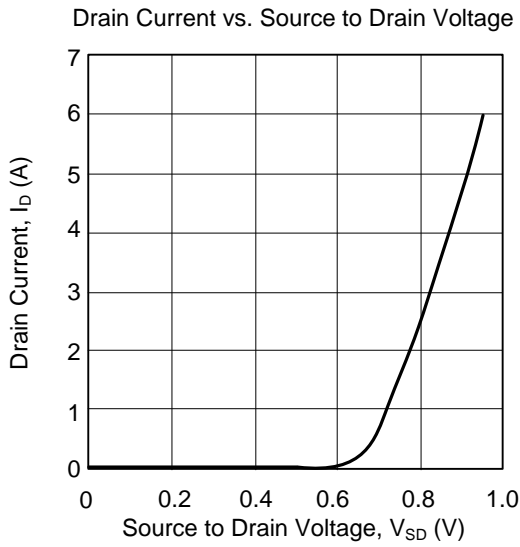

UTC assumes no responsibility for equipment failures that result from using products at values that exceed, even momentarily, rated values (such as maximum ratings, operating condition ranges, or other parameters) listed in products specifications of any and all UTC products described or contained herein. UTC products are not designed for use in life support appliances, devices or systems where malfunction of these products can be reasonably expected to result in personal injury. Reproduction in whole or in part is prohibited without the prior written consent of the copyright owner. UTC reserves the right to make changes to information published in this document, including without limitation specifications and product descriptions, at any time and without notice. This document supersedes and replaces all information supplied prior to the publication hereof.