

30mA Low Power LDO

Features

- Low power consumption
- Low voltage drop
- Low temperature coefficient
- High input voltage (up to +18V)
- Output voltage accuracy: tolerance $\pm 2\%$
- TO-92, SOT-89 and SOT-25 package

Applications

- Battery-powered equipment
- Communication equipment
- Audio/Video equipment

General Description

The 71XX-1 series is a set of three-terminal low power high voltage regulators implemented in CMOS technology. They allow input voltages as high as 24V. They are available with several fixed output voltages ranging from 3.0V to 5.0V. CMOS technology ensures low voltage drop and low quiescent current.

Although designed primarily as fixed voltage regulators, these devices can be used with external components to obtain variable voltages and currents.

Part No.	Output Voltage	Package	Marking
7130-1	3.0V	TO-92 SOT-89 SOT-25	71XXA-1 (for TO-92) 71XX-1 (for SOT-89) 1XX1 (for SOT-25)
7133-1	3.3V		
7136-1	3.6V		
7144-1	4.4V		
7150-1	5.0V		

Note: "XX" stands for output voltages.

Block Diagram

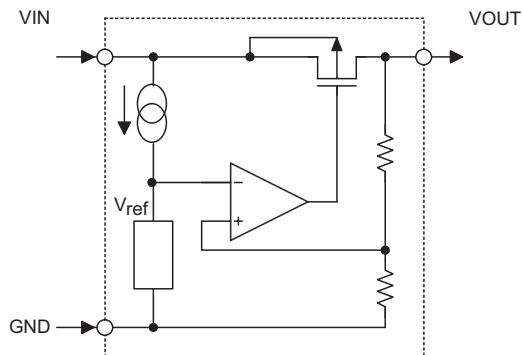

Pin Assignment

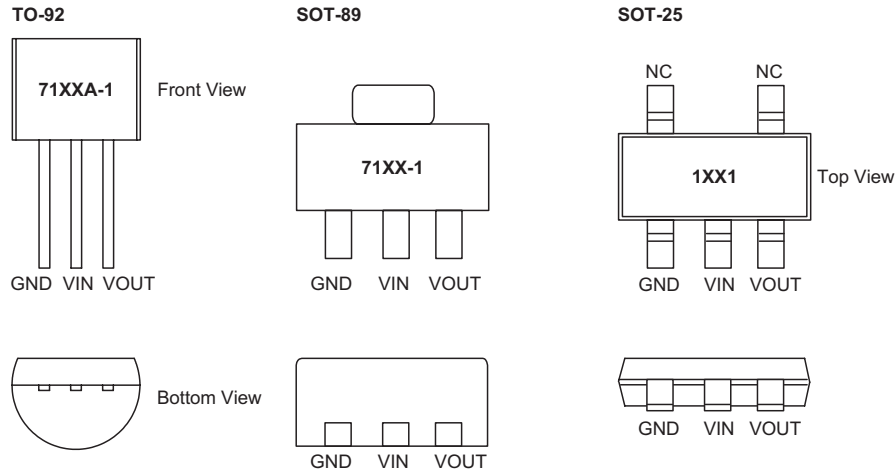

Absolute Maximum Ratings

Supply Voltage	-0.3V to 26V	Storage Temperature	-50°C to 125°C
Power Consumption (*1)	200mW	Operating Temperature	-40°C to 85°C
Power Consumption (*2)	150mW		

Note: These are stress ratings only. Stresses exceeding the range specified under "Absolute Maximum Ratings" may cause substantial damage to the device. Functional operation of this device at other conditions beyond those listed in the specification is not implied and prolonged exposure to extreme conditions may affect device reliability.

*1: applied to SOT-89 and TO-92

*2: applied to SOT-25

Electrical Characteristics

7130-1, +3.0V Output Type

Ta=25°C

Symbol	Parameter	Test Conditions		Min.	Typ.	Max.	Unit
		V _{IN}	Conditions				
V _{OUT}	Output Voltage	5V	I _{OUT} =10mA	2.91	3	3.09	V
I _{OUT}	Output Current	5V	—	20	30	—	mA
ΔV _{OUT}	Load Regulation	5V	1mA ≤ I _{OUT} ≤ 20mA	—	60	100	mV
V _{DIF}	Voltage Drop	—	I _{OUT} =1mA	—	100	—	mV
I _{SS}	Current Consumption	5V	No load	—	2.5	5	μA
$\frac{\Delta V_{OUT}}{\Delta V_{IN} \times V_{OUT}}$	Line Regulation	—	4V ≤ V _{IN} ≤ 24V I _{OUT} =1mA	—	0.2	—	%/V
V _{IN}	Input Voltage	—	—	—	—	24	V
$\frac{\Delta V_{DET}}{\Delta T_a}$	Temperature Coefficient	5V	I _{OUT} =10mA 0°C < T _a < 70°C	—	±0.45	—	mV/°C

7133-1, +3.3V Output Type

Ta=25°C

Symbol	Parameter	Test Conditions		Min.	Typ.	Max.	Unit
		V _{IN}	Conditions				
V _{OUT}	Output Voltage	5.5V	I _{OUT} =10mA	3.201	3.3	3.399	V
I _{OUT}	Output Current	5.5V	—	20	30	—	mA
ΔV _{OUT}	Load Regulation	5.5V	1mA≤I _{OUT} ≤30mA	—	60	100	mV
V _{DIF}	Voltage Drop	—	I _{OUT} =1mA	—	100	—	mV
I _{SS}	Current Consumption	5.5V	No load	—	2.5	5	μA
$\frac{\Delta V_{OUT}}{\Delta V_{IN} \times V_{OUT}}$	Line Regulation	—	4.5V≤V _{IN} ≤24V I _{OUT} =1mA	—	0.2	—	%/V
V _{IN}	Input Voltage	—	—	—	—	24	V
$\frac{\Delta V_{DET}}{\Delta T_a}$	Temperature Coefficient	5.5V	I _{OUT} =10mA 0°C<Ta<70°C	—	±0.5	—	mV/°C

7136-1, +3.6V Output Type

Ta=25°C

Symbol	Parameter	Test Conditions		Min.	Typ.	Max.	Unit
		V _{IN}	Conditions				
V _{OUT}	Output Voltage	5.6V	I _{OUT} =10mA	3.492	3.6	3.708	V
I _{OUT}	Output Current	5.6V	—	20	30	—	mA
ΔV _{OUT}	Load Regulation	5.6V	1mA≤I _{OUT} ≤30mA	—	60	100	mV
V _{DIF}	Voltage Drop	—	I _{OUT} =1mA	—	60	—	mV
I _{SS}	Current Consumption	5.6V	No load	—	2.5	5	μA
$\frac{\Delta V_{OUT}}{\Delta V_{IN} \times V_{OUT}}$	Line Regulation	—	4.6V≤V _{IN} ≤24V I _{OUT} =1mA	—	0.2	—	%/V
V _{IN}	Input Voltage	—	—	—	—	24	V
$\frac{\Delta V_{DET}}{\Delta T_a}$	Temperature Coefficient	5.6V	I _{OUT} =10mA 0°C<Ta<70°C	—	±0.6	—	mV/°C

7150-1, +5.0V Output Type

Ta=25°C

Symbol	Parameter	Test Conditions		Min.	Typ.	Max.	Unit
		V _{IN}	Conditions				
V _{OUT}	Output Voltage	7V	I _{OUT} =10mA	4.85	5	5.15	V
I _{OUT}	Output Current	7V	—	20	30	—	mA
ΔV _{OUT}	Load Regulation	7V	1mA≤I _{OUT} ≤30mA	—	60	100	mV
V _{DIF}	Voltage Drop	—	I _{OUT} =1mA	—	100	—	mV
I _{SS}	Current Consumption	7V	No load	—	2.5	5	μA
$\frac{\Delta V_{OUT}}{\Delta V_{IN} \times V_{OUT}}$	Line Regulation	—	6V≤V _{IN} ≤24V I _{OUT} =1mA	—	0.2	—	%/V
V _{IN}	Input Voltage	—	—	—	—	24	V
$\frac{\Delta V_{DET}}{\Delta T_a}$	Temperature Coefficient	7V	I _{OUT} =10mA 0°C<Ta<70°C	—	±0.75	—	mV/°C

Package Information

3-pin TO-92 Outline Dimensions

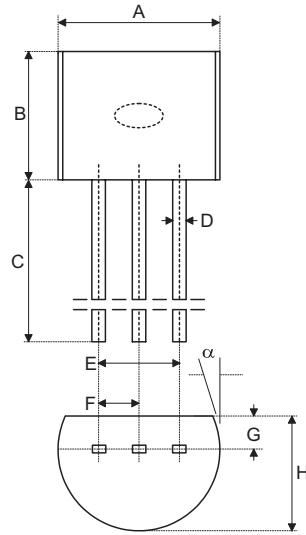

Symbol	Dimensions in mil		
	Min.	Nom.	Max.
A	170	—	200
B	170	—	200
C	500	—	—
D	11	—	20
E	90	—	110
F	45	—	55
G	45	—	65
H	130	—	160
I	8	—	18
α	4°	—	6°

3-pin SOT-89 Outline Dimensions

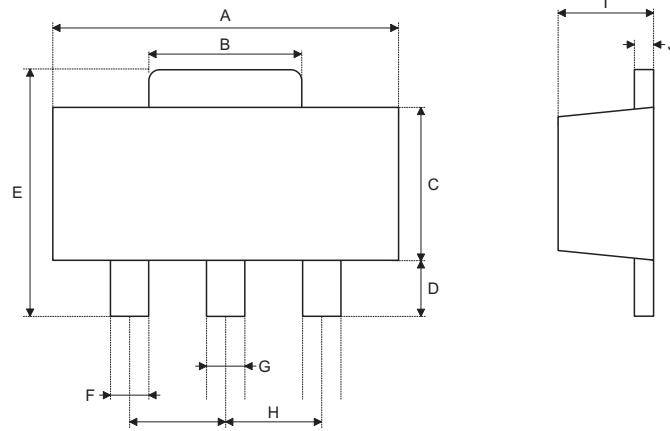

Symbol	Dimensions in mil		
	Min.	Nom.	Max.
A	173	—	181
B	64	—	72
C	90	—	102
D	35	—	47
E	155	—	167
F	14	—	19
G	17	—	22
H	—	59	—
I	55	—	63
J	14	—	17

5-pin SOT-25 Outline Dimensions

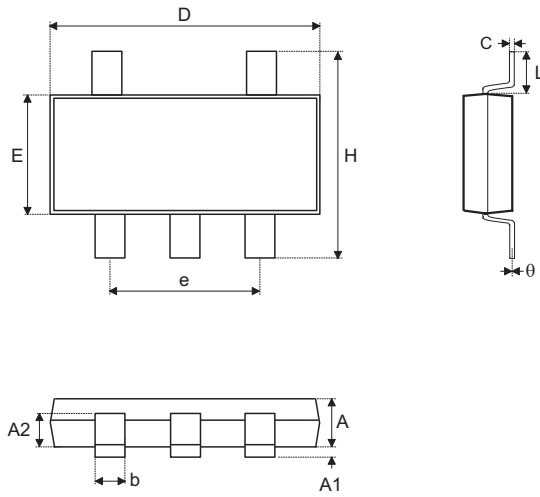

Symbol	Dimensions in mm		
	Min.	Nom.	Max.
A	1.00	—	1.30
A1	—	—	0.10
A2	0.70	—	0.90
b	0.35	—	0.50
C	0.10	—	0.25
D	2.70	—	3.10
E	1.40	—	1.80
e	—	1.90	—
H	2.60	—	3
L	0.37	—	—
θ	1°	—	9°