



71M6545/71M6545H Metrology Processors

GENERAL DESCRIPTION

The 71M6545/71M6545H metrology processors are based on 4th-generation metering architecture supporting the 71M6xxx series of isolated current sensing products that offer drastic reduction in component count, immunity to magnetic tampering, and unparalleled reliability. The 71M6545/71M6545H integrate our Single Converter Technology® with a 22-bit delta-sigma ADC, a customizable 32-bit computation engine (CE) for core metrology functions, as well as a user-programmable 8051-compatible application processor (MPU) core with up to 64KB flash and up to 5KB RAM.

An external host processor can access metrology functions directly through the SPI™ interface, or alternatively through the embedded MPU core in applications requiring metrology data capture, storage, and preprocessing within the metrology subsystem. In addition, the devices integrate an RTC, DIO, and UART. A complete array of ICE and development tools, programming libraries, and reference designs enable rapid development and certification of meters that meet all ANSI and IEC electricity metering standards worldwide.

FEATURES

- 0.1% Typical Accuracy Over 2000:1 Current Range
- Exceeds IEC 62053/ANSI C12.20 Standards
- Seven Sensor Inputs with Neutral Current Measurement, Differential Mode Selectable for Current Inputs
- Selectable Gain of 1 or 8 for One Current Input to Support Shunts
- High-Speed Wh/VARh Pulse Outputs with Programmable Width
- Flash/RAM Size
 - 32KB/3KB (71M6545)
 - 64KB/5KB (71M6545H)
- Up to Four Pulse Outputs with Pulse Count
- Four-Quadrant Metering, Phase Sequencing
- Digital Temperature Compensation
 - Metrology Compensation
 - Accurate RTC for TOU Functions with Automatic Temperature Compensation for Crystal in All Power Modes
- Independent 32-Bit Compute Engine
- 46–64Hz Line Frequency Range with the Same Calibration
- Phase Compensation (7)
- 1 A Supply Current in Sleep Mode
- Flash Security
- In-System Program Update
- 8-Bit MPU (80515), Up to 5 MIPS, for Optional Implementation of Postprocessing and Host Support Functions (Optional Use)
- Up to 29 DIO Pins
- Hardware Watchdog Timer (WDT)
- I²C/MICROWIRE® EEPROM Interface
- SPI Interface for Host:
 - Full Access to Shared Memory Space
 - Flash Program Capability
- UART
- Industrial Temperature Range
- 64-Pin Lead(Pb)-Free LQFP Package

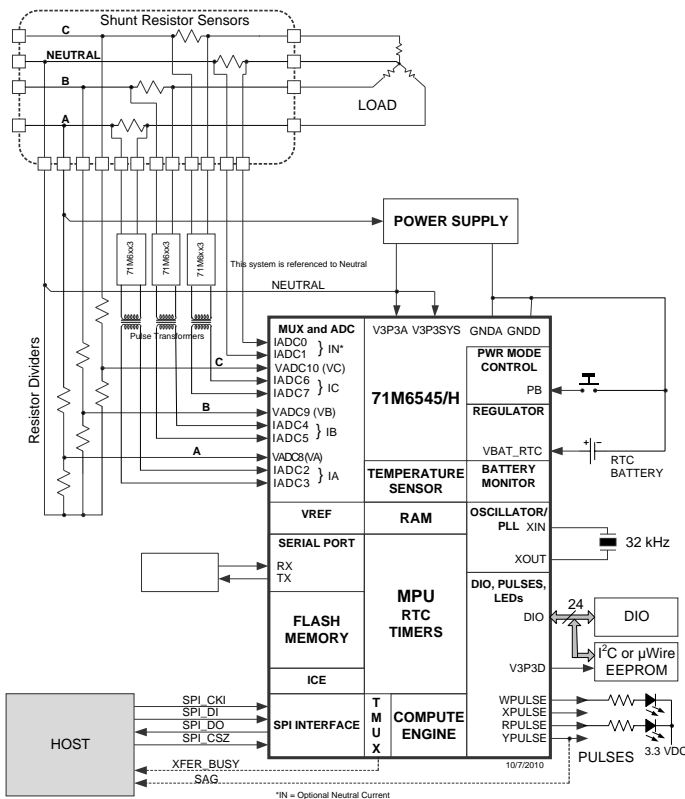

Single Converter Technology is a registered trademark of Silergy Corp
MICROWIRE is a registered trademark of National Semiconductor Corp.

Table of Contents

1	Introduction	9
2	Hardware Description	10
2.1	Hardware Overview	10
2.2	Analog Front End (AFE).....	11
2.2.1	Signal Input Pins.....	12
2.2.2	Input Multiplexer.....	13
2.2.3	Delay Compensation	18
2.2.4	ADC Pre-Amplifier	19
2.2.5	A/D Converter (ADC)	19
2.2.6	FIR Filter	19
2.2.7	Voltage References	19
2.2.8	71M6xx3 Isolated Sensor Interface	20
2.3	Digital Computation Engine (CE).....	24
2.3.1	CE Program Memory	24
2.3.2	CE Data Memory	24
2.3.3	CE Communication with the MPU	24
2.3.4	Meter Equations.....	25
2.3.5	Real-Time Monitor (RTM)	25
2.3.6	Pulse Generators.....	25
2.3.7	CE Functional Overview	27
2.4	80515 MPU Core	29
2.4.1	MPU Setup Code.....	29
2.4.2	80515 MPU Overview.....	29
2.4.3	Memory Organization and Addressing	30
2.4.4	Special Function Registers (SFRs).....	32
2.4.5	Generic 80515 Special Function Registers	33
2.4.6	Instruction Set.....	35
2.4.7	UARTs	35
2.4.8	Timers and Counters	37
2.4.9	WD Timer (Software Watchdog Timer)	39
2.4.10	Interrupts.....	39
2.5	On-Chip Resources	45
2.5.1	Physical Memory.....	45
2.5.2	Oscillator.....	47
2.5.3	PLL and Internal Clocks.....	47
2.5.4	Real-Time Clock (RTC)	48
2.5.5	71M6545/H Temperature Sensor	52
2.5.6	71M6xx3 Temperature Sensor	53
2.5.7	71M6545/H Battery Monitor.....	54
2.5.8	71M6xx3 VCC Monitor.....	54
2.5.9	UART Interface	54
2.5.10	DIO Pins.....	54
2.5.11	EEPROM Interface	56
2.5.12	SPI Slave Port.....	59
2.5.13	Hardware Watchdog Timer.....	63
2.5.14	Test Ports (TMUXOUT and TMUX2OUT Pins)	63

3	Functional Description	65
3.1	Theory of Operation	65
3.2	SLP Mode (Sleep Mode).....	65
3.3	Fault and Reset Behavior	67
3.3.1	Events at Power-Down	67
3.3.2	Reset Sequence	67
3.4	Data Flow and Host Communication	68
4	Application Information.....	70
4.1	Connecting 5 V Devices.....	70
4.2	Directly Connected Sensors	70
4.3	Systems Using 71M6xx3 Isolated Sensors and Current Shunts	71
4.4	System Using Current Transformers	72
4.5	Metrology Temperature Compensation	73
4.5.1	Distinction Between Standard and High-Precision Parts	73
4.5.2	Temperature Coefficients for the 71M6545	74
4.5.3	Temperature Coefficients for the 71M6545H	74
4.5.4	Temperature Coefficients for the 71M6603 and 71M6103 (1% Energy Accuracy)	74
4.5.5	Temperature Compensation for VREF and Shunt Sensors	74
4.5.6	Temperature Compensation of VREF and Current Transformers.....	76
4.6	Connecting I ² C EEPROMs	78
4.7	Connecting Three-Wire EEPROMs	78
4.8	UART (TX/RX)	78
4.9	Connecting the Reset Pin	78
4.10	Connecting the Emulator Port Pins.....	79
4.11	Flash Programming.....	79
4.11.1	Flash Programming via the ICE Port	79
4.11.2	Flash Programming via the SPI Port	79
4.12	MPU Demonstration Code	79
4.13	Crystal Oscillator.....	80
4.14	Meter Calibration.....	80
5	Firmware Interface	81
5.1	I/O RAM Map –Functional Order	81
5.2	I/O RAM Map – Alphabetical Order	87
5.3	Reading the Info Page (71M6545H only)	97
5.4	CE Interface Description	99
5.4.1	CE Program	99
5.4.2	CE Data Format.....	99
5.4.3	Constants.....	99
5.4.4	Environment.....	100
5.4.5	CE Calculations	100
5.4.6	CE Front End Data (Raw Data)	101
5.4.7	CE Status and Control	102
5.4.8	CE Transfer Variables	104
5.4.9	Pulse Generation	106
5.4.10	CE Calibration Parameters	109
5.4.11	CE Flow Diagrams.....	110

6	71M6545/H Specifications	112
6.1	Absolute Maximum Ratings	112
6.2	Recommended External Components	113
6.3	Recommended Operating Conditions	113
6.4	Performance Specifications	114
6.4.1	Input Logic Levels	114
6.4.2	Output Logic Levels	114
6.4.3	Battery Monitor	114
6.4.4	Temperature Monitor	115
6.4.5	Supply Current	116
6.4.6	V3P3D Switch	116
6.4.7	Internal Power Fault Comparators	117
6.4.8	2.5 V Voltage Regulator – System Power	117
6.4.9	Crystal Oscillator	117
6.4.10	Phase-Locked Loop (PLL)	118
6.4.11	71M6545/H VREF	119
6.4.12	ADC Converter (71M6545/H)	120
6.4.13	Pre-Amplifier for IADC0-IADC1	121
6.5	Timing Specifications	122
6.5.1	Flash Memory	122
6.5.2	SPI Slave	122
6.5.3	EEPROM Interface	122
6.5.4	RESET Pin	123
6.5.5	Real-Time Clock (RTC)	123
6.6	64-Pin LQFP Package Outline Drawing	124
6.7	71M6545/H Pinout	125
6.8	71M6545/H Pin Descriptions	126
6.8.1	71M6545/H Power and Ground Pins	126
6.8.2	71M6545/H Analog Pins	127
6.8.3	71M6545/H Digital Pins	128
6.8.4	I/O Equivalent Circuits	129
7	Ordering Information	130
7.1	71M6545/H Ordering Guide	130
8	Related Information	130
9	Contact Information	130
Appendix A: Acronyms		131
Appendix B: Revision History		132

Figures

Figure 1: IC Functional Block Diagram	8
Figure 2: AFE Block Diagram (Shunts: One-Local, Three-Remotes).....	11
Figure 3: AFE Block Diagram (Four CTs)	12
Figure 4: States in a Multiplexer Frame ($MUX_DIV[3:0] = 6$)	16
Figure 5: States in a Multiplexer Frame ($MUX_DIV[3:0] = 7$)	16
Figure 6: General Topology of a Chopped Amplifier	19
Figure 7: CROSS Signal with $CHOP_E = 00$	20
Figure 8: RTM Timing	25
Figure 9: Pulse Generator FIFO Timing.....	27
Figure 10: Samples from Multiplexer Cycle (Frame)	28
Figure 11: Accumulation Interval	28
Figure 12: Interrupt Structure	44
Figure 13: Automatic Temperature Compensation	51
Figure 14: Connecting an External Load to DIO Pins	56
Figure 15: 3-wire Interface. Write Command, HiZ=0.	58
Figure 16: 3-wire Interface. Write Command, HiZ=1	58
Figure 17: 3-wire Interface. Read Command.....	58
Figure 18: 3-Wire Interface. Write Command when CNT=0.....	58
Figure 19: 3-wire Interface. Write Command when HiZ=1 and WFR=1.	58
Figure 20: SPI Slave Port - Typical Multi-Byte Read and Write operations.....	60
Figure 21: Voltage, Current, Momentary and Accumulated Energy	65
Figure 22: Data Flow.....	68
Figure 23: Resistive Voltage Divider (Voltage Sensing)	70
Figure 24: CT with Single-Ended Input Connection (Current Sensing)	70
Figure 25: CT with Differential Input Connection (Current Sensing)	70
Figure 26: Differential Resistive Shunt Connections (Current Sensing).....	70
Figure 27: System Using Three-Remotes and One-Local (Neutral) Sensor	71
Figure 28: System Using Current Transformers	72
Figure 29: I ² C EEPROM Connection	78
Figure 30: Connections for the UART	78
Figure 31: External Components for the RESET Pin: Push-Button (Left), Production Circuit (Right).....	79
Figure 32: External Components for the Emulator Interface	79
Figure 33: Trim Fuse Bit Mapping.....	97
Figure 34: CE Data Flow: Multiplexer and ADC.....	110
Figure 35: CE Data Flow: Scaling, Gain Control, Intermediate Variables for one Phase.....	110
Figure 36: CE Data Flow: Squaring and Summation Stages.....	111
Figure 37: 64-pin LQFP Package Outline	124
Figure 38: Pinout for the LQFP-64 Package.....	125
Figure 39: I/O Equivalent Circuits	129

Tables

Table 1: Required CE Code and Settings for 1-Local / 3-Remotes	14
Table 2: Required CE Code and Settings for CT Sensors	15
Table 3: Multiplexer and ADC Configuration Bits.....	18
Table 4: <i>RCMD[4:0]</i> Bits	21
Table 6: I/O RAM Control Bits for Isolated Sensor	23
Table 7: Inputs Selected in Multiplexer Cycles	25
Table 8: CKMPU Clock Frequencies	30
Table 9: Memory Map	31
Table 10: Internal Data Memory Map	32
Table 11: Special Function Register Map	32
Table 12: Generic 80515 SFRs - Location and Reset Values	33
Table 13: <i>PSW</i> Bit Functions (SFR 0xD0)	34
Table 14: Port Registers (DIO0-14)	35
Table 15: Stretch Memory Cycle Width	35
Table 16: Baud Rate Generation	36
Table 17: UART Modes.....	36
Table 18: The <i>SOCON</i> (UART0) Register (SFR 0x98).....	37
Table 19: <i>PCON</i> Register Bit Description (<i>SFR 0x87</i>)	37
Table 20: Timers/Counters Mode Description	38
Table 21: Allowed Timer/Counter Mode Combinations	38
Table 22: <i>TMOD</i> Register Bit Description (SFR 0x89).....	38
Table 23: The <i>TCON</i> Register Bit Functions (SFR 0x88).....	39
Table 24: The <i>IEN0</i> Bit Functions (SFR 0xA8).....	40
Table 25: The <i>IEN1</i> Bit Functions (SFR 0xB8).....	40
Table 26: The <i>IEN2</i> Bit Functions (SFR 0x9A).....	40
Table 27: <i>TCON</i> Bit Functions (SFR 0x88)	40
Table 28: The <i>T2CON</i> Bit Functions (SFR 0xC8).....	41
Table 29: The <i>IRCON</i> Bit Functions (SFR 0xC0)	41
Table 30: External MPU Interrupts.....	41
Table 31: Interrupt Enable and Flag Bits	42
Table 32: Interrupt Priority Level Groups	42
Table 33: Interrupt Priority Levels	43
Table 34: Interrupt Priority Registers (<i>IP0</i> and <i>IP1</i>)	43
Table 35: Interrupt Polling Sequence.....	43
Table 36: Interrupt Vectors.....	43
Table 37: Flash Memory Access.....	45
Table 38: Flash Security	46
Table 39: Clock System Summary.....	48
Table 40: RTC Control Registers	49
Table 41: I/O RAM Registers for RTC Temperature Compensation	50
Table 42: I/O RAM Registers for RTC Interrupts	52
Table 43: I/O RAM Registers for Temperature and Battery Measurement	53
Table 44: Data/Direction Registers and Internal Resources for DIO0 to DIO14	54
Table 45: Data/Direction Registers for DIO19-25 and DIO28-29	55
Table 46: Data/Direction Registers for DIO55	55
Table 47: Selectable Resources using the <i>DIO_Rn[2:0]</i> Bits	55
Table 48: <i>EECTRL</i> Bits for 2-pin Interface.....	56
Table 49: <i>EECTRL</i> Bits for the 3-wire Interface.....	57
Table 50: SPI Transaction Fields.....	60
Table 51: SPI Command Sequences.....	61
Table 52: SPI Registers	61
Table 53: <i>TMUX[4:0]</i> Selections	63
Table 54: <i>TMUX2[4:0]</i> Selections	64
Table 55: Available Circuit Functions.....	66
Table 56: <i>VSTAT[2:0]</i> (SFR 0xF9[2:0]).....	67
Table 57: GAIN_ADJn Compensation Channels (Figure 2, Figure 27, Table 1).....	75
Table 58: GAIN_ADJx Compensation Channels (Figure 3, Figure 28, Table 2).....	77

Table 59: I/O RAM Map – Functional Order, Basic Configuration	81
Table 60: I/O RAM Map – Functional Order	83
Table 61: I/O RAM Map – Alphabetical Order	87
Table 62: Info Page Trim Fuses.....	97
Table 63: CE <i>EQU</i> [2:0] Equations and Element Input Mapping.....	100
Table 64: CE Raw Data Access Locations	101
Table 65: <i>CESTATUS</i> Register.....	102
Table 66: <i>CESTATUS</i> Bit Definitions	102
Table 67: <i>CECONFIG</i> Register.....	102
Table 68: <i>CECONFIG</i> Bit Definitions (CE RAM 0x20).....	103
Table 69: Sag Threshold, Phase Measurement, and Gain Adjust Control.....	104
Table 70: CE Transfer Variables (with Shunts).....	104
Table 71: CE Transfer Variables (with CTs)	105
Table 72: CE Energy Measurement Variables (with Shunts)	105
Table 73: CE Energy Measurement Variables (with CTs)	105
Table 74: Other Transfer Variables.....	106
Table 75: CE Pulse Generation Parameters.....	107
Table 76: CE Parameters for Noise Suppression and Code Version.....	108
Table 77: CE Calibration Parameters	109
Table 78: Absolute Maximum Ratings	112
Table 79: Recommended External Components	113
Table 80: Recommended Operating Conditions	113
Table 81: Input Logic Levels	114
Table 82: Output Logic Levels	114
Table 83: Battery Monitor Performance Specifications (<i>TEMP_BAT</i> = 1)	114
Table 84: Temperature Monitor	115
Table 85: Supply Current Performance Specifications	116
Table 86: V3P3D Switch Performance Specifications	116
Table 87: 2.5 V Voltage Regulator Performance Specifications (VDD pin).....	117
Table 88: Crystal Oscillator Performance Specifications	117
Table 89: PLL Performance Specifications.....	118
Table 90: 71M6545/H VREF Performance Specifications	119
Table 91: ADC Converter Performance Specifications.....	120
Table 92: Pre-Amplifier Performance Specifications	121
Table 93: Flash Memory Timing Specifications	122
Table 94: SPI Slave Timing Specifications	122
Table 95: EEPROM Interface Timing.....	122
Table 96: RESET Pin Timing	123
Table 97: RTC Range for Date	123
Table 98: 71M6545/H Power and Ground Pins	126
Table 99: 71M6545/H Analog Pins	127
Table 100: 71M6545/H Digital Pins	128
Table 101: 71M6545/H Ordering Guide.....	130

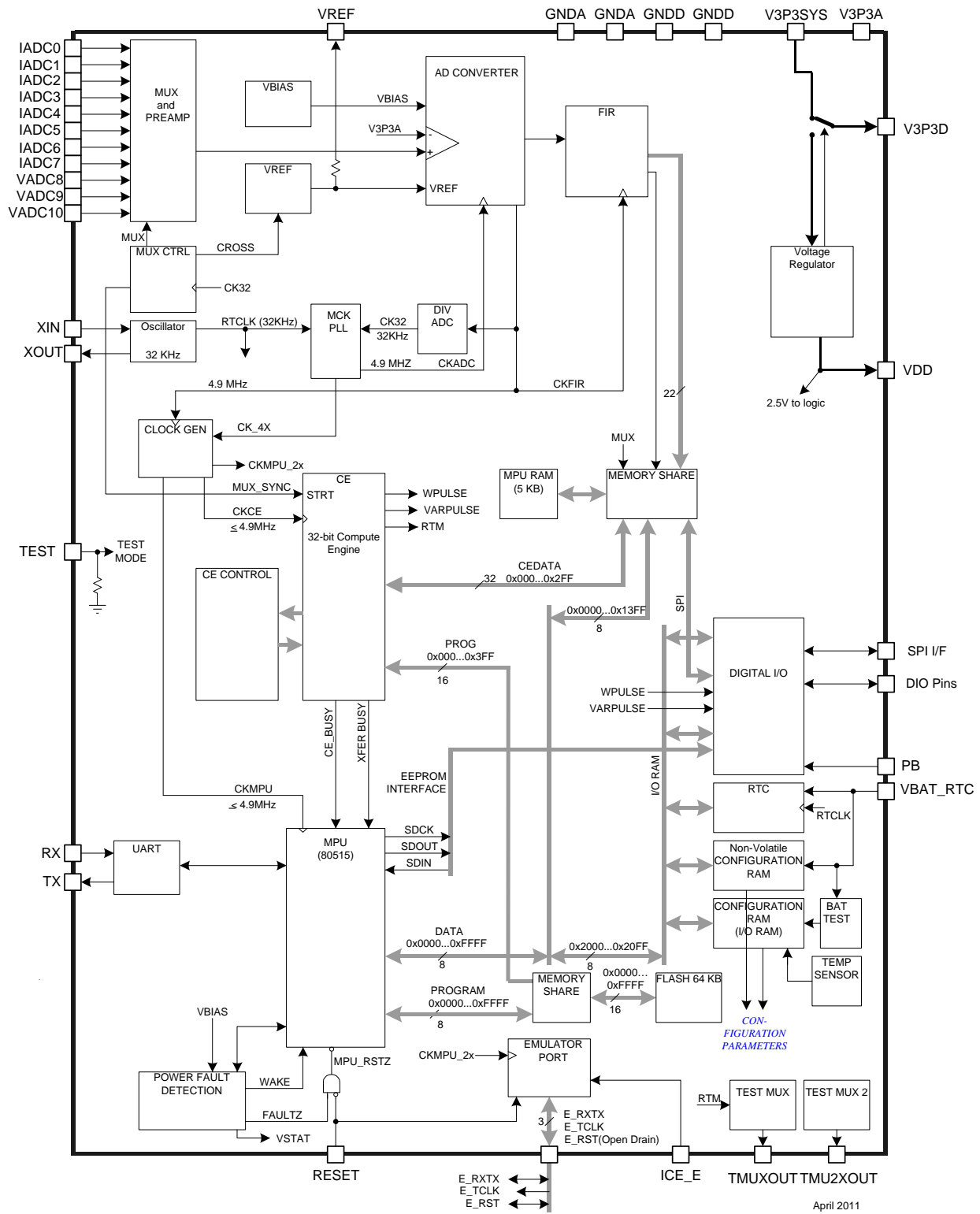

Figure 1: IC Functional Block Diagram

1 Introduction

This data sheet covers the 71M6545 and 71M6545H fourth generation poly-phase Metrology Processors. The term “71M6545/H” is used when discussing a device feature or behavior that is applicable to both part numbers. The appropriate part number is indicated when a device feature or behavior is being discussed that applies only to a specific part number. This data sheet also covers details about the companion 71M6xx3 isolated current sensor device.

This document covers the use of the 71M6545/H in conjunction with the 71M6xx3 isolated current sensor. The 71M6545/H and 71M6xx3 ICs make it possible to use one non-isolated and three additional isolated shunt current sensors to create poly-phase energy meters using inexpensive shunt resistors, while achieving unprecedented performance with this type of sensor technology. The 71M6545/H Metrology Processors also support Current Transformers (CT).

To facilitate document navigation, hyperlinks are often used to reference figures, tables and section headings that are located in other parts of the document. All hyperlinks in this document are highlighted in [blue](#). Hyperlinks are used extensively to increase the level of detail and clarity provided within each section by referencing other relevant parts of the document. To further facilitate document navigation, this document is published as a PDF document with bookmarks enabled.

The reader is also encouraged to obtain and review the documents listed in [8 RELATED INFORMATION](#) on page [130](#) of this document.

2 HARDWARE DESCRIPTION

2.1 Hardware Overview

The 71M6545/H single-chip Metrology Processor integrates all primary functional blocks required to implement a solid-state electricity meter. Included on the chip are:

- An analog front end (AFE) featuring a 22-bit second-order sigma-delta ADC
- An independent 32-bit digital computation engine (CE) to implement DSP functions
- An 8051-compatible microprocessor (MPU) which executes one instruction per clock cycle (80515)
- A precision voltage reference (VREF)
- A temperature sensor for digital temperature compensation:
 - Metrology digital temperature compensation (MPU)
 - Automatic RTC digital temperature compensation operational in sleep mode (SLP)
- RAM and Flash memory
- A real time clock (RTC)
- A variety of I/O pins
- A power failure interrupt (CE code feature)
- A zero-crossing interrupt (CE code feature)
- Selectable current sensor interfaces for locally-connected sensors as well as isolated sensors (i.e., using the 71M6xx3 companion IC with a shunt resistor sensor)
- Resistive Shunt and Current Transformers are supported

In order to implement a poly-phase meter with or without neutral current sensing, one resistive shunt current sensor may be connected directly (non-isolated) to the 71M6545/H device, while three additional current shunts are isolated using a companion 71M6xx3 isolated sensor IC. An inexpensive, small size pulse transformer is used to electrically isolate the 71M6xx3 remote sensor from the 71M6545/H. The 71M6545/H performs digital communications bi-directionally with the 71M6xx3 and also provides power to the 71M6xx3 through the isolating pulse transformer. Isolated (remote) shunt current sensors are connected to the differential input of the 71M6xx3. The 71M6545/H may also be used with Current Transformers; in this case the 71M6xx3 isolated sensors are not required. Included on the 71M6xx3 companion isolator chip are:

- Digital isolation communications interface
- An analog front end (AFE) featuring a 22-bit second-order sigma-delta ADC
- A precision voltage reference (VREF)
- A temperature sensor (for current-sensing digital temperature compensation)
- A fully differential shunt resistor sensor input
- A pre-amplifier to optimize shunt current sensor performance
- Isolated power circuitry obtains dc power from pulses sent by the 71M6545/H

In a typical application, the 32-bit compute engine (CE) of the 71M6545/H sequentially processes the samples from the voltage inputs on analog input pins and performs calculations to measure active energy (Wh) and reactive energy (VARh), as well as A^2h , and V^2h for four-quadrant metering. These measurements are then accessed by the host processor via the SPI or by the on-chip MPU, to be processed further and output using either the peripheral devices available to the on-chip MPU or by the host processor.

In addition to advanced measurement functions, the real time clock (RTC) function allows the 71M6545/H to record time of use (TOU) metering information for multi-rate applications and to time-stamp tamper or other events. An automatic RTC temperature compensation circuit operates in all power states including when the MPU is halted, and continues to compensate using back-up battery power during power outages (VBAT_RTC pin).

In addition to the temperature-trimmed ultra-precision voltage reference, the on-chip digital temperature compensation mechanism includes a temperature sensor and associated controls for correction of unwanted temperature effects on metrology and RTC accuracy (i.e., to meet the requirements of ANSI and IEC standards). Temperature-dependent external components such as the crystal, current transformers (CTs), Current Shunts and their corresponding signal conditioning circuits can be characterized and their

correction factors can be programmed to produce electricity meters with exceptional accuracy over the industrial temperature range.

One of the two internal UARTs is adapted to support an Infrared LED with internal drive and sense configuration and can also function as a standard UART. This flexibility makes it possible to implement AMR meters with an IR interface. A block diagram of the IC is shown in [Figure 1](#).

2.2 Analog Front End (AFE)

The AFE functions as a data acquisition system, controlled by the MPU or by the host processor over the SPI interface. The 71M6545/H AFE may also be augmented by isolated 71M6xx3 sensors in order to support low-cost current shunt sensors. [Figure 2](#) and [Figure 3](#) show two of the most common configurations; other configurations are possible. Sensors that are connected directly to the 71M6545/H (i.e., IADC0-IADC1, VADC8, VADC9 and VADC10) are multiplexed into the single second-order sigma-delta ADC input for sampling in the 71M6545/H. The 71M6545/H ADC output is decimated by the FIR filter and stored in CE RAM where it can be accessed and processed by the CE.

Shunt current sensors that are isolated by using a 71M6xx3 device, are sampled by a second-order sigma delta ADC in the 71M6xx3 and the signal samples are transferred over the digital isolation interface through the low-cost isolation pulse transformer.

[Figure 2](#) shows the 71M6545/H using shunt current sensors and the 71M6xx3 isolated sensor devices. [Figure 2](#) supports neutral current measurement with a local shunt connected to the IADC0-IADC1 input plus three remote (isolated) shunt sensors. As seen in [Figure 2](#), when a remote isolated shunt sensor is connected via the 71M6xx3, the samples associated with this current channel are not routed to the multiplexer, and are instead transferred digitally to the 71M6545/H via the isolation interface and are directly stored in CE RAM. The $MUX_SELn[3:0]$ I/O RAM control fields allow the MPU to configure the AFE for the desired multiplexer sampling sequence. Refer to [Table 1](#) and [Table 2](#) for the appropriate CE code and the corresponding AFE settings.

See [Figure 27](#) for the meter wiring configuration corresponding to [Figure 2](#).

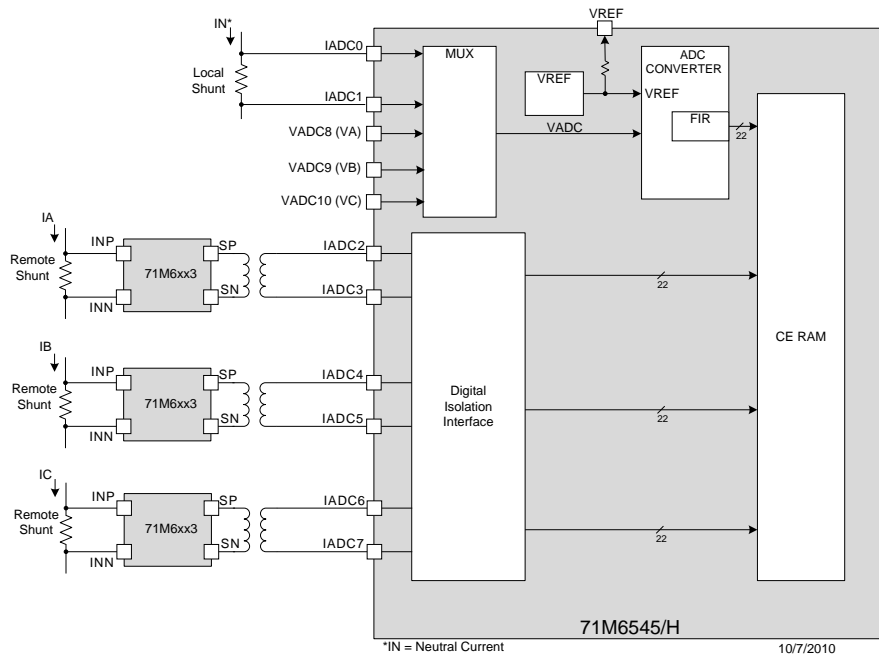

Figure 2: AFE Block Diagram (Shunts: One-Local, Three-Remotes)

The 71M6545/H AFE can also be directly interfaced to Current Transformers (CTs), as seen in [Figure 3](#). In this case, all voltage and current channels are multiplexed into a single second-order sigma-delta ADC in the 71M6545/H and the 71M6xx3 remote isolated sensors are not used. The fourth CT and the measurement of Neutral current via the IADC0-IADC1 current channel are optional.

See [Figure 28](#) for the meter wiring configuration corresponding to [Figure 3](#).

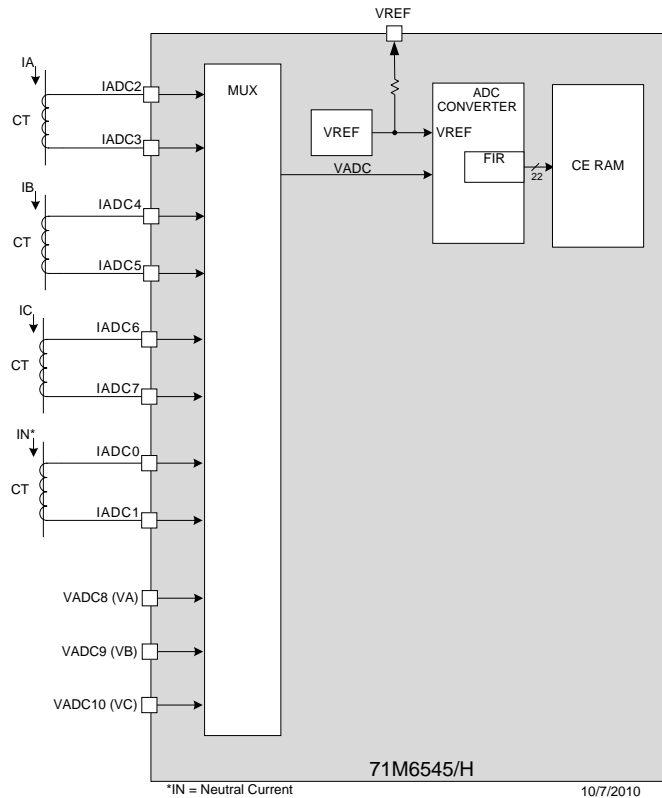

Figure 3. AFE Block Diagram (Four CTs)

2.2.1 Signal Input Pins

The 71M6545/H features eleven ADC input pins.

IADC0 through IADC7 are intended for use as current sensor inputs. These eight current sensor inputs can be configured as four single-ended inputs, or can be paired to form four differential inputs. For best performance, it is recommended to configure the current sensor inputs as differential inputs (i.e., IADC0-IADC1, IADC2-IADC3, IADC4-IADC5 and IADC6-IADC7). The first differential input (IADC0-IADC1) features a pre-amplifier with a selectable gain of 1 or 8, and is intended for direct connection to a shunt resistor sensor, and can also be used with a Current Transformer (CT). The three remaining differential pairs (i.e., IADC2-IADC3, IADC4-IADC5 and IADC6-IADC7) may be used with CTs, or may be enabled to interface to a remote 71M6xx3 isolated current sensor providing isolation for a shunt resistor sensor using a low cost pulse transformer.

The remaining three inputs VADC8 (VA), VADC9 (VB) and VADC10 (VC) are single-ended, and are intended for sensing each of the phase voltages in a poly-phase meter application. These three single-ended inputs are referenced to the V3P3A pin.

All ADC input pins measure voltage. In the case of shunt current sensors, currents are sensed as a voltage drop in the shunt resistor sensor. In the case of Current Transformers (CT), the current is measured as a voltage across a burden resistor that is connected to the secondary of the CT. Meanwhile, line voltages are sensed through resistive voltage dividers. The VADC8 (VA), VADC9 (VB) and VADC10 (VC) pins are single-ended and their common return is the V3P3A pin. See [Figure 23](#), [Figure 24](#), [Figure 25](#) and [Figure 26](#) for detailed connections for each type of sensor.

Pins IADC0-IADC1 can be programmed individually to be differential or single-ended as determined by the *DIFF0_E* (I/O RAM 0x210C[4]) control bit. However, for most applications, IADC0-IADC1 are

configured as a differential input to work with a resistive shunt or CT directly interfaced to the IADC0-IADC1 differential input with the appropriate external signal conditioning components.

The performance of the IADC0-IADC1 pins can be enhanced by enabling a pre-amplifier with a fixed gain of 8, using the I/O RAM control bit *PRE_E* (I/O RAM 0x2704[5]). When *PRE_E* = 1, IADC0-IADC1 become the inputs to the 8x pre-amplifier, and the output of this amplifier is supplied to the multiplexer. The 8x amplification is useful when current sensors with low sensitivity, such as shunt resistors, are used. With *PRE_E* set, the IADC0-IADC1 input signal amplitude is restricted to 31.25 mV peak. When *PRE_E* = 0 (Gain = 1), the IADC0-IADC1 input signal is restricted to 250 mV peak.

For the 71M6545/H application utilizing shunt resistor sensors (Figure 2), the IADC0-IADC1 pins are configured for differential mode to interface to a local shunt by setting the *DIFFO_E* control bit. Meanwhile, the IADC2-IADC3, IADC4-IADC5 and IADC6-IADC7 pins are re-configured as digital remote sensor interface designed to communicate with a 71M6xx3 isolated sensor by setting the *RMTx_E* control bits (I/O RAM 0x2709[5:3]). The 71M6xx3 communicates with the 71M6545/H using a bi-directional digital data stream through an isolating low-cost pulse transformer. The 71M6545/H also supplies power to the 71M6xx3 through the isolating transformer. This type of interface is further described at the end of this chapter. See 2.2.8 71M6xx3 Isolated Sensor Interface.

For use with Current Transformers (CTs), as shown in Figure 3, the *RMTx_E* control bits are reset, so that IADC2-IADC3, IADC4-IADC5 and IADC6-IADC7 are configured as local analog inputs. The IADC0-IADC1 pins cannot be configured as a remote sensor interface.

2.2.2 Input Multiplexer

When operating with locally connected sensors, the input multiplexer sequentially applies the input signals from the analog input pins to the input of the ADC (see Figure 3), according to the sampling sequence determined by the eleven *MUXn_SEL[3:0]* control fields. One complete sampling sequence is called a multiplexer frame. The multiplexer of the 71M6545/H can select up to eleven input signals when the current sensor inputs are configured for single-ended mode. When the current sensor inputs are configured in differential mode (recommended for best performance), the number of input signals is seven (i.e., IADC0-IADC1, IADC2-IADC3, IADC4-IADC5, IADC6-IADC7, VADC8, VADC9 and VADC10) per multiplexer frame. The number of slots in the multiplexer frame is controlled by the I/O RAM control field *MUX_DIV[3:0]* (I/O RAM 0x2100[7:4]) (see Figure 4). The multiplexer always starts at state 0 and proceeds until the number of sensor channels determined by the *MUX_DIV[3:0]* field setting have been converted.

The 71M6545/H requires a unique CE code that is written for the specific meter configuration. Moreover, each CE code requires specific AFE and MUX settings in order to function properly. Table 1 provides the CE code and settings corresponding to the 1-Local / 3-Remote sensor configuration shown in Figure 2. Table 2 provides the CE code and settings corresponding to the CT configuration shown in Figure 3.

Table 1. Required CE Code and Settings for 1-Local / 3-Remotes

I/O RAM Mnemonic	I/O RAM Location	I/O RAM Setting	Comments
<i>FIR_LEN[1:0]</i>	210C[2:1]	1	288 cycles
<i>ADC_DIV</i>	2200[5]	0	Fast
<i>PLL_FAST</i>	2200[4]	1	19.66 MHz
<i>MUX_DIV[3:0]</i>	2100[7:4]	6	See note 1
<i>MUX0_SEL[3:0]</i>	2105[3:0]	0	Slot 0 is IADC0-IADC1 (IN)
<i>MUX1_SEL[3:0]</i>	2105[7:4]	1	Unused (See note 2)
<i>MUX2_SEL[3:0]</i>	2104[3:0]	1	Unused (See note 2)
<i>MUX3_SEL[3:0]</i>	2104[7:4]	8	Slot 3 is VADC8 (VA)
<i>MUX4_SEL[3:0]</i>	2103[3:0]	9	Slot 4 is VADC9 (VB)
<i>MUX5_SEL[3:0]</i>	2103[7:4]	A	Slot 5 is VADC10 (VC)
<i>MUX6_SEL[3:0]</i>	2102[3:0]	0	Slots not enabled
<i>MUX7_SEL[3:0]</i>	2102[7:4]	0	
<i>MUX8_SEL[3:0]</i>	2101[3:0]	0	
<i>MUX9_SEL[3:0]</i>	2101[7:4]	0	
<i>MUX10_SEL[3:0]</i>	2100[3:0]	0	
<i>RMT2_E</i>	2709[3]	1	Enable Remote IADC2-IADC3 (IA)
<i>RMT4_E</i>	2709[4]	1	Enable Remote IADC4-IADC5 (IB)
<i>RMT6_E</i>	2709[5]	1	Enable Remote IADC6-IADC7 (IC)
<i>DIFF0_E</i>	210C[4]	1	Differential IADC0-IADC1 (IN)
<i>DIFF2_E</i>	210C[5]	0	See note 3
<i>DIFF4_E</i>	210C[6]	0	See note 3
<i>DIFF6_E</i>	210C[7]	0	See note 3
<i>PRE_E</i>	2704[5]	1	IADC0-IADC1 Gain = 8
<i>EQU[2:0]</i>	2106[7:5]	5	$IA*VA + IB*VB + IC*VC$
CE Codes (See note 4)	ce43b016603 (use with 71M6603) ce43b016103 (use with 71M6103) ce43b016113 (use with 71M6113) ce43b016203 (use with 71M6203)		
Equation(s)	5		
Current Sensor Type	1 Local Shunt and 3 Remote Shunts		
Applicable Figures	Figure 2 and Figure 27		
Notes:			
1. <i>MUX_DIV[3:0]</i> must be set to 0 while writing the other RAM locations in this table.			
2. Each unused slot must be assigned to a valid (0 to A), but unused ADC handle.			
3. This channel is remote (71M6xx3), hence <i>DIFF_x_E</i> is irrelevant.			
4. Must use the CE code that corresponds to the specific 71M6xx3 device used.			
Silergy updates the CE code periodically. Contact Silergy to obtain the latest CE code and the associated settings.			

Table 2. Required CE Code and Settings for CT Sensors

I/O RAM Mnemonic	I/O RAM Location	I/O RAM Setting (Hex)	Comments
<i>FIR_LEN[1:0]</i>	210C[2:1]	1	288 cycles
<i>ADC_DIV</i>	2200[5]	0	Fast
<i>PLL_FAST</i>	2200[4]	1	19.66 MHz
<i>MUX_DIV[3:0]</i>	2100[7:4]	7	See note 1
<i>MUX0_SEL[3:0]</i>	2105[3:0]	2	Slot 0 is IADC2-IADC3 (IA)
<i>MUX1_SEL[3:0]</i>	2105[7:4]	8	Slot 1 is VADC8 (VA)
<i>MUX2_SEL[3:0]</i>	2104[3:0]	4	Slot 2 is IADC4-IADC5 (IB)
<i>MUX3_SEL[3:0]</i>	2104[7:4]	9	Slot 3 is VADC9 (VB)
<i>MUX4_SEL[3:0]</i>	2103[3:0]	6	Slot 4 is IADC6-IADC7 (IC)
<i>MUX5_SEL[3:0]</i>	2103[7:4]	A	Slot 5 is VADC10 (VC)
<i>MUX6_SEL[3:0]</i>	2102[3:0]	0	Slot 6 is IADC0-IADC1 (IN – See note 2)
<i>MUX7_SEL[3:0]</i>	2102[7:4]	0	Slots not enabled
<i>MUX8_SEL[3:0]</i>	2101[3:0]	0	
<i>MUX9_SEL[3:0]</i>	2101[7:4]	0	
<i>MUX10_SEL[3:0]</i>	2100[3:0]	0	
<i>RMT2_E</i>	2709[3]	0	Local Sensor IADC2-IADC3
<i>RMT4_E</i>	2709[4]	0	Local Sensor IADC4-IADC5
<i>RMT6_E</i>	2709[5]	0	Local Sensor IADC6-IADC7
<i>DIFF0_E</i>	210C[4]	1	Differential IADC0-IADC1
<i>DIFF2_E</i>	210C[5]	1	Differential IADC2-IADC3
<i>DIFF4_E</i>	210C[6]	1	Differential IADC4-IADC5
<i>DIFF6_E</i>	210C[7]	1	Differential IADC6-IADC7
<i>PRE_E</i>	2704[5]	0	IADC0-IADC1 Gain = 1
<i>EQU[2:0]</i>	2106[7:5]	5	IA*VA + IB*VB + IC*VC
CE Code	ce43a02		
Equation(s)	5		
Current Sensor Type	4 Current Transformers (CTs)		
Applicable Figures	Figure 3 and Figure 28		
Notes:			
1. <i>MUX_DIV[3:0]</i> must be set to 0 while writing the other RAM locations in this table.			
2. IN is the optional Neutral Current.			
Silergy updates the CE code periodically. Contact Silergy to obtain the latest CE code and the associated settings.			



Using settings for the I/O RAM Mnemonics listed in Table 1 and Table 2 that do not match those required by the corresponding CE code being used may result in undesirable side effects and must not be selected by the MPU. Consult Silergy to obtain the correct CE code and AFE / MUX settings corresponding to the application.

For a poly-phase configuration with neutral current sensing using shunt resistor current sensors and the 71M6xx3 isolated sensors, as shown in Figure 2, the IADC0-IADC1 input must be configured as a differential input, to be connected to a local shunt (see Figure 26 for the shunt connection details). The local shunt connected to the IADC0-IADC1 input is used to sense the Neutral current. The voltage sensors (VADC8, VADC9 and VADC10) are also directly connected to the 71M6545/H (see Figure 23 for the connection details) and are also routed through the multiplexer, as seen in Figure 2. Meanwhile, the

IADC2-IADC3, IADC4-IADC5 and IADC6-IADC7 current inputs are configured as remote sensor digital interfaces and the corresponding samples are not routed through the multiplexer. For this configuration, the multiplexer sequence is as shown in [Figure 4](#).

For a poly-phase configuration with optional neutral current sensing using Current Transformer (CTs) sensors, as shown in [Figure 3](#), all four current sensor inputs must be configured as a differential inputs, to be connected to their corresponding CTs (see [Figure 25](#) for the differential CT connection details). The IADC0-IADC1 current sensor input is optionally used to sense the Neutral current for anti-tampering purposes. The voltage sensors (VADC8, VADC9 and VADC10) are directly connected to the 71M6545/H (see [Figure 23](#) for the voltage sensor connection details). No 71M6xx3 isolated sensors are used in this configuration and all sensors are routed through the multiplexer, as seen in [Figure 3](#). For this configuration, the multiplexer sequence is as shown in [Figure 5](#).

The multiplexer sequence shown in [Figure 4](#), covers the shunt configuration shown in [Figure 2](#). The frame duration is 13 CK32 cycles (where CK32 = 32,768 Hz), therefore, the resulting sample rate is $32,768 \text{ Hz} / 13 = 2,520.6 \text{ Hz}$. Note that [Figure 4](#) only shows the currents that pass through the 71M6545/H multiplexer, and does not show the currents that are copied directly into CE RAM from the remote sensors (see [Figure 2](#)), which are sampled during the second half of the multiplexer frame. The two unused conversion slots shown are necessary to produce the desired 2,520.6 Hz sample rate.

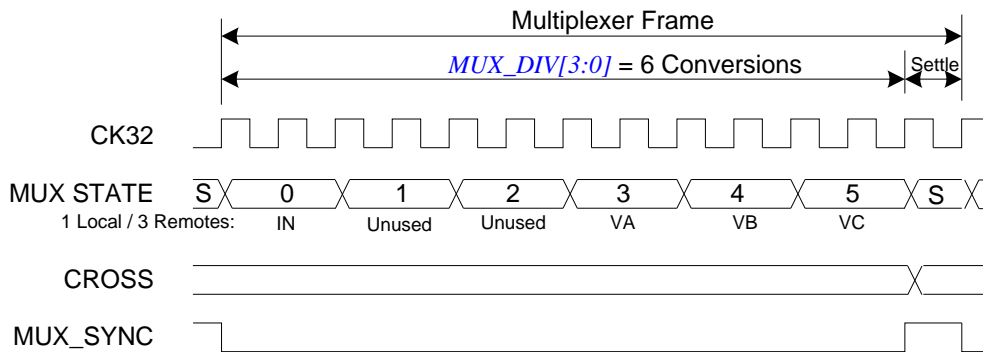

Figure 4: States in a Multiplexer Frame ($MUX_DIV[3:0] = 6$)

The multiplexer sequence shown in [Figure 5](#) corresponds to the CT configuration shown in [Figure 3](#). Since in this case all current sensors are locally connected to the 71M6545/H, all currents are routed through the multiplexer, as seen in [Figure 3](#). For this multiplexer sequence, the frame duration is 15 CK32 cycles (where CK32 = 32,768 Hz), therefore, the resulting sample rate is $32,768 \text{ Hz} / 15 = 2,184.5 \text{ Hz}$.

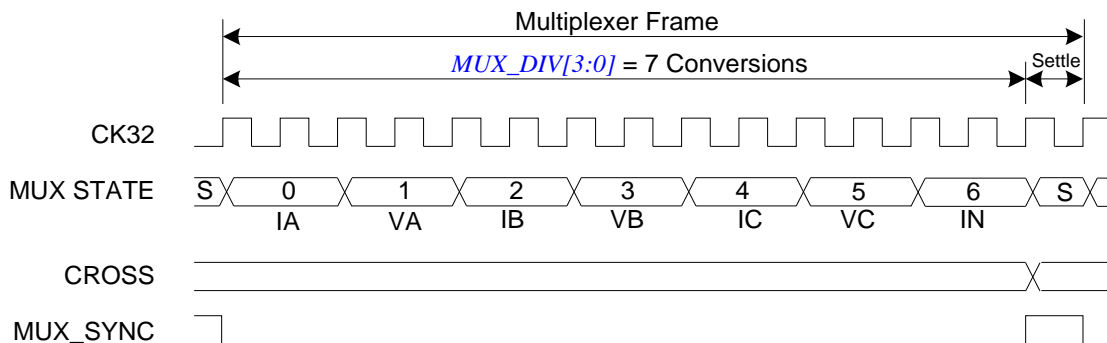

Figure 5: States in a Multiplexer Frame ($MUX_DIV[3:0] = 7$)

Multiplexer advance, FIR initiation and chopping of the ADC reference voltage (using the internal CROSS signal, see [2.2.7 Voltage References](#)) are controlled by the internal MUX_CTRL circuit. Additionally, MUX_CTRL launches each pass of the CE through its code. Conceptually, MUX_CTRL is clocked by CK32, the 32768 Hz clock from the PLL block. The behavior of the MUX_CTRL circuit is governed by:

CHOP_E[1:0] (I/O RAM 0x2106[3:2])

MUX_DIV[3:0] (I/O RAM 0x2100[7:4])

FIR_LEN[1:0] (I/O RAM 0x210C[2:1])

ADC_DIV (I/O RAM 0x2200[5])

The duration of each multiplexer state depends on the number of ADC samples processed by the FIR as determined by the *FIR_LEN[1:0]* (I/O RAM 0x210C[2:1]) control field. Each multiplexer state starts on the rising edge of CK32, the 32-kHz clock.



It is required that *MUX_DIV[3:0]* (I/O RAM 0x2100[7:4]) be set to zero while changing the ADC configuration to minimize system transients. After all configuration bits are set, *MUX_DIV[3:0]* should be set to the required value.

The duration of each time slot in CK32 cycles depends on *FIR_LEN[1:0]*, *ADC_DIV* and *PLL_FAST*:

$$\text{Time_Slot_Duration} (PLL_FAST = 1) = (FIR_LEN[1:0]+1) * (ADC_DIV+1)$$

$$\text{Time_Slot_Duration} (PLL_FAST = 0) = 3*(FIR_LEN[1:0]+1) * (ADC_DIV+1)$$

The duration of a multiplexer frame in CK32 cycles is:

$$\text{MUX_Frame_Duration} = 3-2*PLL_FAST + \text{Time_Slot_Duration} * MUX_DIV[3:0]$$

The duration of a multiplexer frame in CK_FIR cycles is:

MUX frame duration (CK_FIR cycles) =

$$[3-2*PLL_FAST + \text{Time_Slot_Duration} * MUX_DIV] * (48+PLL_FAST*102)$$

The ADC conversion sequence is programmable through the *MUXn_SEL* control fields (I/O RAM 0x2100 to 0x2105). As stated above, there are up to eleven ADC time slots in the 71M6545/H, as set by *MUX_DIV[3:0]* (I/O RAM 0x2100[7:4]). In the expression *MUXn_SEL[3:0] = x*, 'n' refers to the multiplexer frame time slot number and 'x' refers to the desired ADC input number or ADC handle (i.e., IADC0 to VADC10, or simply 0 to 10 decimal). Thus, there are a total of 11 valid ADC handles in the 71M6545/H devices. For example, if *MUX0_SEL[3:0] = 0*, then IADC0, corresponding to the sample from the IADC0-IADC1 input (configured as a differential input), is positioned in the multiplexer frame during time slot 0. See [Table 1](#) and [Table 2](#) for the appropriate *MUXn_SEL[3:0]* settings and other settings applicable to a particular meter configuration and CE code.

Note that when the remote sensor interface is enabled, the samples corresponding to the remote sensor currents do not pass through the 71M6545/H multiplexer. The sampling of the remote current sensors occurs in the second half of the multiplexer frame. The VA, VB and VC voltages are assigned the last three slots in the frame. With this slot assignment for VA, VB and VC, the sampling of the corresponding remote sensor currents bears a precise timing relationship to their corresponding phase voltages, and delay compensation is accurately performed (see [2.2.3 Delay Compensation](#) on page 18).

Also when using remote sensors, it is necessary to introduce unused slots to realize the number of slots specified by the *MUX_DIV[3:0]* (I/O RAM 0x2100[7:4]) field setting (see [Figure 4](#) and [Figure 5](#)). The *MUXn_SEL[3:0]* control fields for these unused ("dummy") slots must be written with a valid ADC handle (i.e., 0 to 10 decimal) that is not otherwise being used. In this manner, the unused ADC handle, is used as a "dummy" place holder in the multiplexer frame, and the correct duration multiplexer frame sequence is generated and also the desired sample rate. The resulting sample data stored in the CE RAM location corresponding to the "dummy" ADC handle is ignored by the CE code. Meanwhile, the digital isolation interface takes care of automatically storing the samples for the remote current sensors in the appropriate CE RAM locations.



Delay compensation and other functions in the CE code require the settings for *MUX_DIV[3:0]*, *MUXn_SEL[3:0]*, *RMT_E*, *FIR_LEN[1:0]*, *ADC_DIV* and *PLL_FAST* to be fixed for a given CE code. Refer to [Table 1](#) and [Table 2](#) for the settings that are applicable to the 71M6545/H.

[Table 3](#) summarizes the I/O RAM registers used for configuring the multiplexer, signals pins, and ADC. All listed registers are 0 after reset and wake from SLP mode, and are readable and writable.

Table 3: Multiplexer and ADC Configuration Bits

Name	Location	Description
<i>MUX0_SEL[3:0]</i>	2105[3:0]	Selects the ADC input converted during time slot 0.
<i>MUX1_SEL[3:0]</i>	2105[7:4]	Selects the ADC input converted during time slot 1.
<i>MUX2_SEL[3:0]</i>	2104[3:0]	Selects the ADC input converted during time slot 2.
<i>MUX3_SEL[3:0]</i>	2104[7:4]	Selects the ADC input converted during time slot 3.
<i>MUX4_SEL[3:0]</i>	2103[3:0]	Selects the ADC input converted during time slot 4.
<i>MUX5_SEL[3:0]</i>	2103[7:4]	Selects the ADC input converted during time slot 5.
<i>MUX6_SEL[3:0]</i>	2102[3:0]	Selects the ADC input converted during time slot 6.
<i>MUX7_SEL[3:0]</i>	2102[7:0]	Selects the ADC input converted during time slot 7.
<i>MUX8_SEL[3:0]</i>	2101[3:0]	Selects the ADC input converted during time slot 8.
<i>MUX9_SEL[3:0]</i>	2101[7:0]	Selects the ADC input converted during time slot 9.
<i>MUX10_SEL[3:0]</i>	2100[3:0]	Selects the ADC input converted during time slot 10.
<i>ADC_DIV</i>	2200[5]	Controls the rate of the ADC and FIR clocks.
<i>MUX_DIV[3:0]</i>	2100[7:4]	The number of ADC time slots in each multiplexer frame (maximum = 11).
<i>PLL_FAST</i>	2200[4]	Controls the speed of the PLL and MCK.
<i>FIR_LEN[1:0]</i>	210C[2:1]	Determines the number of ADC cycles in the ADC decimation FIR filter.
<i>DIFF0_E</i>	210C[4]	Enables the differential configuration for analog input pins IADC0-IADC1 .
<i>DIFF2_E</i>	210C[5]	Enables the differential configuration for analog input pins IADC2-IADC3 .
<i>DIFF4_E</i>	210C[6]	Enables the differential configuration for analog input pins IADC4-IADC5 .
<i>DIFF6_E</i>	210C[7]	Enables the differential configuration for analog input pins IADC6-IADC7 .
<i>RMT2_E</i>	2709[3]	Enables the remote sensor interface transforming pins IADC2-IADC3 into a digital interface for communications with a 71M6xx3 sensor.
<i>RMT4_E</i>	2709[4]	Enables the remote sensor interface transforming pins IADC4-IADC5 into a digital interface for communications with a 71M6xx3 sensor.
<i>RMT6_E</i>	2709[5]	Enables the remote sensor interface transforming pins IADC6-IADC7 into a digital interface for communications with a 71M6xx3 sensor.
<i>PRE_E</i>	2704[5]	Enables the 8x pre-amplifier.
Refer to Table 61 starting on page 87 for more complete details about these I/O RAM locations.		

2.2.3 Delay Compensation

When measuring the energy of a phase (i.e., Wh and VARh) in a service, the voltage and current for that phase must be sampled at the same instant. Otherwise, the phase difference, ϕ , introduces errors.

$$\frac{t_{delay}}{T} 360^\circ \quad t_{delay} f 360^\circ$$

Where f is the frequency of the input signal, $T = 1/f$ and t_{delay} is the sampling delay between current and voltage.

Traditionally, sampling is accomplished by using two A/D converters per phase (one for voltage and the other one for current) controlled to sample simultaneously. Single-Converter Technology, however, exploits the 32-bit signal processing capability of its CE to implement “constant delay” all-pass filters. The all-pass filter corrects for the conversion time difference between the voltage and the corresponding current samples that are obtained with a single multiplexed A/D converter.

The “constant delay” all-pass filter provides a broad-band delay $360^\circ - \phi$, that is precisely matched to the difference in sample time between the voltage and the current of a given phase. This digital filter does not affect the amplitude of the signal, but provides a precisely controlled phase response.

The recommended ADC multiplexer sequence samples the current first, immediately followed by sampling of the corresponding phase voltage, thus the voltage is delayed by a phase angle ϕ relative to the current. The delay compensation implemented in the CE aligns the voltage samples with their corresponding current samples by first delaying the current samples by one full sample interval (i.e., 360°), then routing the voltage samples through the all-pass filter, thus delaying the voltage samples by $360^\circ - \phi$, resulting in the residual phase error between the current and its corresponding voltage of $-\phi$.

The residual phase error is negligible, and is typically less than ± 1.5 milli-degrees at 100Hz, thus it does not contribute to errors in the energy measurements.

When using remote sensors, the CE performs the same delay compensation described above to align each voltage sample with its corresponding current sample. Even though the remote current samples do not pass through the 71M6545/H multiplexer, their timing relationship to their corresponding voltages is fixed and precisely known, provided that the $MUXn_SEL[3:0]$ slot assignment fields are programmed as shown in [Table 1](#). Note that these slot assignments result in VA, VB and VC occupying multiplexer slots 3, 4 and 5, respectively (see [Figure 4](#)).

2.2.4 ADC Pre-Amplifier

The ADC pre-amplifier is a low-noise differential amplifier with a fixed gain of 8 available only on the IADC0-IADC1 sensor input pins. A gain of 8 is enabled by setting $PRE_E = 1$ (I/O RAM 0x2704[5]). When disabled, the supply current of the pre-amplifier is <10 nA and the gain is unity. With proper settings of the PRE_E and $DIFF0_E$ (I/O RAM 0x210C[4]) bits, the pre-amplifier can be used whether differential mode is selected or not. For best performance, the differential mode is recommended. In order to save power, the bias current of the pre-amplifier and ADC is adjusted according to the ADC_DIV control bit (I/O RAM 0x2200[5]).

2.2.5 A/D Converter (ADC)

A single 2nd order sigma-delta A/D converter digitizes the voltage and current inputs to the device. The resolution of the ADC, including the sign bit, is 21 bits ($FIR_LEN[1:0] = 01$, I/O RAM 0x210C[2:1]), or 22 bits ($FIR_LEN[1:0] = 10$). The ADC is clocked by CKADC.

Initiation of each ADC conversion is controlled by the internal MUX_CTRL circuit as described earlier. At the end of each ADC conversion, the FIR filter output data is stored into the CE RAM location determined by the multiplexer selection.

2.2.6 FIR Filter

The finite impulse response filter is an integral part of the ADC and it is optimized for use with the multiplexer. The purpose of the FIR filter is to decimate the ADC output to the desired resolution. At the end of each ADC conversion, the output data is stored into the fixed CE RAM location determined by the multiplexer selection stored in the $MUXn_SEL[3:0]$ fields. FIR data is stored LSB-justified, but shifted left by 9 bits.

2.2.7 Voltage References

A bandgap circuit provides the reference voltage to the ADC. The amplifier within the reference is chopper stabilized, i.e., the chopper circuit can be enabled or disabled by the MPU using the I/O RAM control field $CHOP_E[1:0]$ (I/O RAM 0x2106[3:2]). The two bits in the $CHOP_E[1:0]$ field enable the MPU to operate the chopper circuit in regular or inverted operation, or in toggling modes (recommended). When the chopper circuit is toggled in between multiplexer cycles, dc offsets on VREF are automatically averaged out, therefore the chopper circuit should always be configured for one of the toggling modes.

Since the VREF band-gap amplifier is chopper-stabilized, the dc offset voltage, which is the most significant long-term drift mechanism in the voltage references (VREF), is automatically removed by the chopper circuit. Both the 71M6545/H and the 71M6xx3 feature chopper circuits for their respective VREF voltage reference.

The general topology of a chopped amplifier is shown in [Figure 6](#). The CROSS signal is an internal on-chip signal and is not accessible on any pin or register.

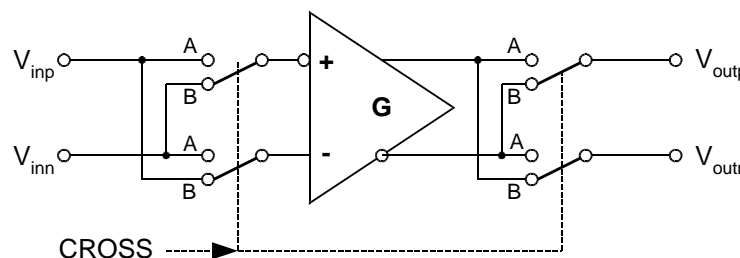

Figure 6: General Topology of a Chopped Amplifier

It is assumed that an offset voltage V_{off} appears at the positive amplifier input. With all switches, as controlled by CROSS (an internal signal), in the A position, the output voltage is:

$$V_{outp} - V_{outn} = G (V_{inp} + V_{off} - V_{inn}) = G (V_{inp} - V_{inn}) + G V_{off}$$

With all switches set to the B position by applying the inverted CROSS signal, the output voltage is:

$$V_{outn} - V_{outp} = G (V_{inn} - V_{inp} + V_{off}) = G (V_{inn} - V_{inp}) + G V_{off}, \text{ or}$$

$$V_{outp} - V_{outn} = G (V_{inp} - V_{inn}) - G V_{off}$$

Thus, when CROSS is toggled, e.g., after each multiplexer cycle, the offset alternately appears on the output as positive and negative, which results in the offset effectively being eliminated, regardless of its polarity or magnitude.

When CROSS is high, the connection of the amplifier input devices is reversed. This preserves the overall polarity of that amplifier gain; it inverts its input offset. By alternately reversing the connection, the amplifier's offset is averaged to zero. This removes the most significant long-term drift mechanism in the voltage reference. The $CHOP_E[1:0]$ (I/O RAM 0x2106[3:2]) control field controls the behavior of CROSS. On the first CK32 rising edge after the last multiplexer state of its sequence, the multiplexer waits one additional CK32 cycle before beginning a new frame. At the beginning of this cycle, the value of CROSS is updated according to the $CHOP_E[1:0]$ field. The extra CK32 cycle allows time for the chopped VREF to settle. During this cycle, MUXSYNC is held high. The leading edge of MUXSYNC initiates a pass through the CE program sequence.

$CHOP_E[1:0]$ has four states: positive, reverse, and two toggle states. In the positive state, $CHOP_E[1:0] = 01$, CROSS is held low. In the reverse state, $CHOP_E[1:0] = 10$, CROSS is held high. The two automatic toggling states are selected by setting $CHOP_E = 11$ or $CHOP_E = 00$.

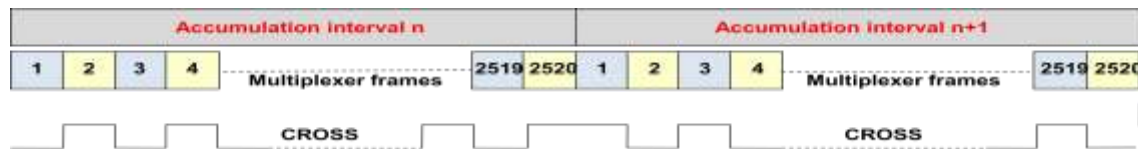

Figure 7: CROSS Signal with $CHOP_E = 00$

Figure 7 shows CROSS over two accumulation intervals when $CHOP_E[1:0] = 00$: At the end of the first interval, CROSS is high, at the end of the second interval, CROSS is low. Operation with $CHOP_E[1:0] = 00$ does not require control of the chopping mechanism by the MPU.

In the second toggle state, $CHOP_E[1:0] = 11$, CROSS does not toggle at the end of the last multiplexer cycle in an accumulation interval.

2.2.8 71M6xx3 Isolated Sensor Interface

2.2.8.1 General Description

Non-isolating sensors, such as shunt resistors, can be connected to the inputs of the 71M6545/H via a combination of a pulse transformer and a 71M6xx3 IC (a top-level block diagram of this sensor interface is shown in Figure 27). The 71M6xx3 receives power directly from the 71M6545/H via a pulse transformer and does not require a dedicated power supply circuit. The 71M6xx3 establishes 2-way communication with the 71M6545/H, supplying current samples and auxiliary information such as sensor temperature via a serial data stream.

Up to three 71M6xx3 Isolated Sensors can be supported by the 71M6545/H. When a remote sensor interface is enabled, the two analog current inputs become re-configured and a digital remote sensor interface. For example, when control bit $RMT2_E = 1$, the IADC2-IADC3 analog pins are re-configured as the digital interface pins to the remote sensor.

Each 71M6xx3 Isolated Sensor consists of the following building blocks:

- Power supply that derives power from pulses received from the 71M6545/H
- Bi-directional digital communications interface

Shunt signal pre-amplifier

22-bit 2nd Order Sigma-Delta ADC Converter with precision bandgap reference (chopping amplifier)

Temperature sensor (for digitally compensating VREF)

Fuse system containing part-specific information

During an ordinary multiplexer cycle, the 71M6545/H internally determines which other channels are enabled with $MUX_DIV[3:0]$ (I/O RAM $0x2100[7:4]$). At the same time, it decimates the modulator output from the 71M6xx3 Isolated Sensors. Each result is written to CE RAM during one of its CE access time slots.

2.2.8.2 Communication between 71M6545/H and 71M6xx3 Isolated Sensor

The ADC of the 71M6xx3 derives its timing from the power pulses generated by the 71M6545/H and as a result, operates its ADC slaved to the frequency of the power pulses. The generation of power pulses, as well as the communication protocol between the 71M6545/H and 71M6xx3 Isolated Sensor, is automatic and transparent to the user. Details are not covered in this data sheet.

2.2.8.3 Control of the 71M6xx3 Isolated Sensor

The 71M6545/H can read or write certain types of information from each 71M6xx3 remote sensor.

The data to be read is selected by a combination of the $RCMD[4:0]$ and $TMUXRn[2:0]$. To perform a read transaction from one of the 71M6xx3 devices, the MPU first writes the $TMUXRn[2:0]$ field (where $n = 2, 4, 6$, located at I/O RAM $0x270A[2:0]$, $0x270A[6:4]$ and $0x2709[2:0]$, respectively). Next, the MPU writes $RCMD[4:0]$ (SFR $0xFC[4:0]$) with the desired command and phase selection. When the $RCMD[4:2]$ bits have cleared to zero, the transaction has been completed and the requested data is available in $RMT_RD[15:0]$ (I/O RAM $0x2602[7:0]$ is the MSB and $0x2603[7:0]$ is the LSB). The read parity error bit, $PERR_RD$ (SFR $0xFC[6]$) is also updated during the transaction. If the MPU writes to $RCMD[4:0]$ before a previously initiated read transaction is completed, the command is ignored. Therefore, the MPU must wait for $RCMD[4:2]=0$ before proceeding to issue the next remote sensor read command.

The $RCMD[4:0]$ field is divided into two sub-fields, $COMMAND=RCMD[4:2]$ and $PHASE=RCMD[1:0]$, as shown in Table 4.

Table 4. $RCMD[4:0]$ Bits

Command $RCMD[4:2]$		Phase Selector $RCMD[1:0]$		Associated $TMUXRn$ Control Field
000	Invalid	00	Invalid	---
001	Command 1	01	IADC2-IADC3	$TMUXR2[2:0]$
010	Command 2	10	IADC4-IADC5	$TMUXR4[2:0]$
011	Reserved	11	IADC6-IADC7	$TMUXR6[2:0]$
100	Reserved			
101	Invalid			
110	Reserved			
111	Reserved			
Notes:				
1. Only two codes of $RCMD[4:2]$ (SFR $0xFC[4:2]$) are relevant for normal operation. These are $RCMD[4:2] = 001$ and 010 . Codes 000 and 101 are invalid and will be ignored if used. The remaining codes are reserved and must not be used.				
2. For the $RCMD[1:0]$ control field, codes 01 , 10 and 11 are valid and 00 is invalid and must not be used.				
3. The specific phase (A, B or C) associated with each $TMUXRn[2:0]$ field, is determined by how the IADCn input pins are connected in the meter design.				

Table 5 shows the allowable combinations of values in $RCMD[4:2]$ and $TMUXRn[2:0]$, and the corresponding data type and format sent back by the 71M6xx3 remote sensor and how the data is stored

in $RMT_RD[15:8]$ and $RMT_RD[7:0]$. The MPU selects which of the three phases is read by asserting the proper code in the $RCMD[1:0]$ field, as shown in [Table 4](#).

Table 5: Remote Interface Read Commands

$RCMD[4:2]$	$TMUXRn[2:0]$	Read Operation	$RMT_RD [15:8]$	$RMT_RD [7:0]$
001	00X	$TRIMT[7:0]$ (trim fuse for all 71M6xx3)	$TRIMT[7]=RMT_RD[8]$	$TRIMT[6:0]=RMT_RD[7:1]$
001	11X	$TRIMBGB[7:0]$ and $TRIMBGD[7:0]$ (additional trim fuses for 71M6113 and 71M6203 only)	$TRIMBGB[7:0]$	$TRIMBGD[7:0]$
010	00X	$STEMP[10:0]$ (sensed 71M6xx3 temperature)	$STEMP[10:8]=RMT_RD[10:8]$ ($RMT_RD[15:11]$ are sign extended)	$STEMP[7:0]$
010	01X	$VSENSE[7:0]$ (sensed 71M6xx3 supply voltage)	All zeros	$VSENSE[7:0]$
010	10X	$VERSION[7:0]$ (chip version)	$VERSION[7:0]$	All zeros

Notes:

1. $TRIMT[7:0]$ is the VREF trim value for all 71M6xx3 devices. Note that the $TRIMT[7:0]$ 8-bit value is formed by $RMT_RD[8]$ and $RMT_RD[7:1]$. See the 71M6xxx Data Sheet for the equations related to $TRIMT[7:0]$ and the corresponding temperature coefficient.
2. $TRIMBGB[7:0]$ and $TRIMBGD[7:0]$ are trim values used for characterizing the 71M6113 (0.5%) and 71M6203 (0.1%) over temperature. See the 71M6xxx Data sheet for the equations related to $TRIMBGB[7:0]$ and $TRIMBGD[7:0]$ and the corresponding temperature coefficients.
3. See [2.5.6 71M6xx3 Temperature Sensor](#) on page 53.
4. See [2.5.8 71M6xx3 VCC Monitor](#) on page 54.

With hardware and trim-related information on each connected 71M6xx3 Isolated Sensor available to the 71M6545/H, the MPU can implement temperature compensation of the energy measurement based on the individual temperature characteristics of the 71M6xx3 Isolated Sensors. See [4.5 Metrology Temperature Compensation](#) for details.

[Table 6](#) shows all I/O RAM registers used for control of the external 71M6xx3 Isolated Sensors. See the 71M6xx3 Data Sheet for additional details.

Table 6: I/O RAM Control Bits for Isolated Sensor

Name	Address	RST Default	WAKE Default	R/W	Description
<i>RCMD[4:0]</i>	SFR FC[4:0]	0	0	R/W	When the MPU writes a non-zero value to <i>RCMD</i> , the 71M6545/H issues a command to the corresponding isolated sensor selected with <i>RCMD[1:0]</i> . When the command is complete, the 71M6545/H clears <i>RCMD[4:2]</i> . The command code itself is in <i>RCMD[4:2]</i> .
<i>PERR_RD</i> <i>PERR_WR</i>	SFR FC[6] SFR FC[5]	0	0	R/W	The 71M6545/H sets these bits to indicate that a parity error on the isolated sensor has been detected. Once set, the bits are remembered until they are cleared by the MPU.
<i>CHOPR[1:0]</i>	2709[7:6]	00	00	R/W	The CHOP settings for the isolated sensors. 00 – Auto chop. Change every multiplexer frame. 01 – Positive 10 – Negative 11 – Same as 00
<i>TMUXR2[2:0]</i>	270A[2:0]	000	000	R/W	The TMUX bits for control of the isolated sensor.
<i>TMUXR4[2:0]</i>	270A[6:4]	000	000	R/W	The TMUX bits for control of the isolated sensor.
<i>TMUXR6[2:0]</i>	2709[2:0]	000	000	R/W	The TMUX bits for control of the isolated sensor.
<i>RMT_RD[15:8]</i> <i>RMT_RD[7:0]</i>	2602[7:0] 2603[7:0]	0	0	R	The read buffer for 71M6xx3 read operations.
<i>RFLY_DIS</i>	210C[3]	0	0	R/W	Controls how the 71M6545/H drives the 71M6xx3 power pulse. When set, the power pulse is driven high and low. When cleared, it is driven high followed by an open circuit flyback interval.
<i>RMT2_E</i>	2709[3]	0	0	R/W	Enables the isolated remote sensor interface and re-configures pins IADC2-IADC3 as a balanced pair digital remote interface.
<i>RMT4_E</i>	2709[4]	0	0	R/W	Enables the isolated remote sensor interface and re-configures pins IADC4-IADC5 as a balanced pair digital remote interface.
<i>RMT6_E</i>	2709[5]	0	0	R/W	Enables the isolated remote sensor interface and re-configures pins IADC6-IADC7 as a balanced pair digital remote interface.

Refer to [Table 61](#) starting on page [87](#) for more complete details about these I/O RAM locations.

2.3 Digital Computation Engine (CE)

The CE, a dedicated 32-bit signal processor, performs the precision computations necessary to accurately measure energy. The CE calculations and processes include:

- Multiplication of each current sample with its associated voltage sample to obtain the energy per sample (when multiplied by the constant sample time).

- Frequency-insensitive delay cancellation on all channels (to compensate for the delay between samples caused by the multiplexing scheme).

- 90° phase shifter (for VAR calculations).

- Pulse generation.

- Monitoring of the input signal frequency (for frequency and phase information).

- Monitoring of the input signal amplitude (for sag detection).

- Scaling of the processed samples based on calibration coefficients.

- Scaling of samples based on temperature compensation information.

2.3.1 CE Program Memory

The CE program resides in flash memory. Common access to flash memory by the CE and MPU is controlled by a memory share circuit. Each CE instruction word is two bytes long. Allocated flash space for the CE program cannot exceed 4096 16-bit words (8 KB). The CE program counter begins a pass through the CE code each time multiplexer state 0 begins. The code pass ends when a HALT instruction is executed. For proper operation, the code pass must be completed before the multiplexer cycle ends.

The CE program must begin on a 1 KB boundary of the flash address. The I/O RAM control field *CE_LCTN[5:0]* (I/O RAM *0x2109[5:0]*) defines which 1 KB boundary contains the CE code. Thus, the first CE instruction is located at $1024 * CE_LCTN[5:0]$.

2.3.2 CE Data Memory

The CE and MPU share data memory (RAM). Common access to XRAM by the CE and MPU is controlled by a memory share circuit. The CE can access up to 3 KB of the 5 KB data RAM (XRAM), i.e. from RAM address 0x0000 to 0x0C00.

The XRAM can be accessed by the FIR filter block, the RTM circuit, the CE, and the MPU. Assigned time slots are reserved for FIR and MPU, respectively, to prevent bus contention for XRAM data access by the CE.

The MPU reads and writes the XRAM shared between the CE and MPU as the primary means of data communication between the two processors.

The CE is aided by support hardware to facilitate implementation of equations, pulse counters, and accumulators. This hardware is controlled through I/O RAM field *EQU[2:0]* (equation assist, I/O RAM *0x2106[7:5]*), bit *DIO_PV* (I/O RAM *0x2457[6]*), bit *DIO_PW* (pulse count assist, I/O RAM *0x2457[7]*), and *SUM_SAMPS[12:0]* (accumulation assist, I/O RAM *0x2107[4:0]* and *0x2108[7:0]*).

The integration time for each energy output, when using standard CE code, is $SUM_SAMPS[12:0] / 2184.53$ (with $MUX_DIV[3:0] = 7$, I/O RAM *0x2100[7:4]*). CE hardware issues the XFER_BUSY interrupt when the accumulation is complete.

2.3.3 CE Communication with the MPU

The CE outputs six signals to the MPU: CE_BUSY, XFER_BUSY, XPULSE, YPULSE, WPULSE and VPULSE. These are connected to the MPU interrupt service. CE_BUSY indicates that the CE is actively processing data. CE_BUSY occurs once every multiplexer frame. XFER_BUSY indicates that the CE is updating to the output region of the CE RAM, which occurs whenever an accumulation cycle has been completed. Both, CE_BUSY and XFER_BUSY are cleared when the CE executes a HALT instruction.

XPULSE and YPULSE can be configured to interrupt the MPU and indicate zero crossings of the mains voltage, sag failures, or other significant events. Additionally, these signals can be connected directly to DIO pins to provide direct outputs from the CE. Interrupts associated with these signals always occur on the leading edge.

2.3.4 Meter Equations

The 71M6545/H provides hardware assistance to the CE in order to support various meter equations. This assistance is controlled through I/O RAM field $EQU[2:0]$ (equation assist, I/O RAM $0x2106[7:5]$). The Compute Engine (CE) firmware for industrial configurations can implement the equations listed in [Table 7](#). $EQU[2:0]$ specifies the equation to be used based on the meter configuration and on the number of phases used for metering.

Table 7: Inputs Selected in Multiplexer Cycles

$EQU[2:0]^*$	Description	Wh and VARh formula			Recommended Multiplexer Sequence
		Element 0	Element 1	Element 2	
2	2-element, 3-W, 3 Delta	$VA \cdot IA$	$VB \cdot IB$	N/A	IA VA IB VB
3	2-element, 4-W, 3 Delta	$VA(IA-IB)/2$	$VC \cdot IC$	N/A	IA VA IB VB IC VC
4	2-element, 4-W, 3 Wye	$VA(IA-IB)/2$	$VB(IC-IB)/2$	N/A	IA VA IB VB IC VC
5	3-element, 4-W, 3 Wye	$VA \cdot IA$	$VB \cdot IB$	$VC \cdot IC$	IA VA IB VB IC VC (ID)

Note:
 * Only $EQU[2:0] = 5$ is supported by the currently available CE code versions for the 71M6545/H. Contact Silergy for CE codes that support equations 2, 3 and 4.

2.3.5 Real-Time Monitor (RTM)

The CE contains a Real-Time Monitor (RTM), which can be programmed to monitor four selectable XRAM locations at full sample rate. The data from the four monitored locations are serially output to the TMUXOUT pin via the digital output multiplexer at the beginning of each CE code pass. The RTM can be enabled and disabled with RTM_E (I/O RAM $0x2106[1]$). The RTM output clock is available on the TMUX2OUT pin. Each RTM word is clocked out in 35 cycles and contains a leading flag bit. See [Figure 8](#) for the RTM output format. RTM is low when not in use.

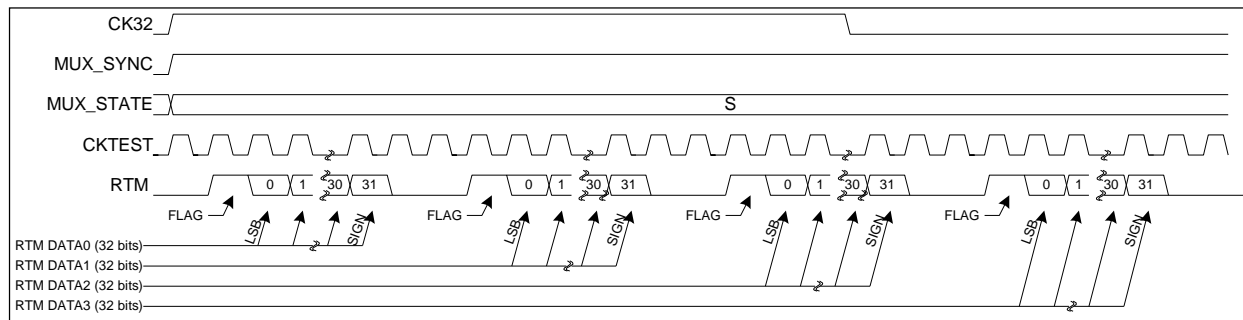

Figure 8: RTM Timing

2.3.6 Pulse Generators

The 71M6545/H provides four pulse generators, VPULSE, WPULSE, XPULSE and YPULSE, as well as hardware support for the VPULSE and WPULSE pulse generators. The XPULSE and YPULSE generators are used by standard CE code to output CE status indicators, for example the status of the sag detection, to DIO pins. All pulses can be configured to generate interrupts to the MPU.

The polarity of the pulses may be inverted with PLS_INV (I/O RAM $0x210C[0]$). When this bit is set, the pulses are active high, rather than the more usual active low. PLS_INV inverts all the pulse outputs.

The function of each pulse generator is determined by the CE code and the MPU code must configure the corresponding pulse outputs in agreement with the CE code. For example, standard CE code produces a mains zero-crossing pulse on XPULSE and a SAG pulse on YPULSE.

A common use of the zero-crossing pulses is to generate interrupts in order to drive real-time clock software in places where the mains frequency is sufficiently accurate to do so and also to adjust for crystal aging. A common use for the SAG pulse is to generate an interrupt that alerts the MPU when mains power is about to fail, so that the MPU code can store accumulated energy and other data to EEPROM before the V3P3SYS supply voltage actually drops.

2.3.6.1 XPULSE and YPULSE

Pulses generated by the CE may be exported to the XPULSE and YPULSE pulse output pins. Pins DIO6 and DIO7 are used for these pulses, respectively. Generally, the XPULSE and YPULSE outputs can be updated once on each pass of the CE code.

See [5.4 CE Interface Description](#) on page 99 for details.

2.3.6.2 VPULSE and WPULSE

Referring to [Figure 9](#), during each CE code pass the hardware stores exported WPULSE and VPULSE sign bits in an 8-bit FIFO and outputs them at a specified interval. This permits the CE code to calculate the VPULSE and WPULSE outputs at the beginning of its code pass and to rely on hardware to spread them over the multiplexer frame. As seen in [Figure 9](#), the FIFO is reset at the beginning of each multiplexer frame. As also seen in [Figure 9](#), the I/O RAM register *PLS_INTERVAL[7:0]* (I/O RAM *0x210B[7:0]*) controls the delay to the first pulse update and the interval between subsequent updates. The LSB of the *PLS_INTERVAL[7:0]* register is equivalent to 4 CK_FIR cycles (CK_FIR is typically 4.9152MHz if *PLL_FAST=1* and *ADC_DIV=0*, but other CK_FIR frequencies are possible; see the ADC_DIV definition in [Table 61](#).) If *PLS_INTERVAL[7:0]=0*, the FIFO is deactivated and the pulse outputs are updated immediately.

The MUX frame duration in units of CK_FIR clock cycles is given by:

If *PLL_FAST=1*:

MUX frame duration in CK_FIR cycles = $[1 + (FIR_LEN+1) * (ADC_DIV+1) * (MUX_DIV)] * [150 / (ADC_DIV+1)]$

If *PLL_FAST=0*:

MUX frame duration in CK_FIR cycles = $[3 + 3*(FIR_LEN+1) * (ADC_DIV+1) * (MUX_DIV)] * [48 / (ADC_DIV+1)]$

PLS_INTERVAL[7:0] in units of CK_FIR clock cycles is calculated by:

$$PLS_INTERVAL[7:0] = \text{floor} (\text{Mux frame duration in CK_FIR cycles} / \text{CE pulse updates per Mux frame} / 4)$$

Since the FIFO resets at the beginning of each multiplexer frame, the user must specify *PLS_INTERVAL[7:0]* so that all of the possible pulse updates occurring in one CE execution are output before the multiplexer frame completes. For instance, the 71M6545/H CE code outputs six updates per multiplexer interval, and if the multiplexer interval is 1950 CK_FIR clock cycles long, the ideal value for the interval is $1950/6/4 = 81.25$. However, if *PLS_INTERVAL[7:0] = 82*, the sixth output occurs too late and would be lost. In this case, the proper value for *PLS_INTERVAL[7:0]* is 81 (i.e., round down the result).

Since one LSB of *PLS_INTERVAL[7:0]* is equal to 4 CK_FIR clock cycles, the pulse time interval T_I in units of CK_FIR clock cycles is:

$$T_I = 4 * PLS_INTERVAL[7:0]$$

If the FIFO is enabled (i.e., *PLS_INTERVAL[7:0] ≠ 0*), hardware also provides a maximum pulse width feature in control register *PLS_MAXWIDTH[7:0]* (I/O RAM *0x210A*). By default, WPULSE and VPULSE are negative pulses (i.e., low level pulses, designed to sink current through an LED). *PLS_MAXWIDTH[7:0]* determines the maximum negative pulse width T_{MAX} in units of CK_FIR clock cycles based on the pulse interval T_I according to the formula:

$$T_{MAX} = (2 * PLS_MAXWIDTH[7:0] + 1) * T_I$$

If *PLS_MAXWIDTH = 255* or *PLS_INTERVAL=0*, no pulse width checking is performed, and the pulses default to 50% duty cycle.

The polarity of the pulses may be inverted with the control bit *PLS_INV* (I/O RAM *0x210C[0]*). When *PLS_INV* is set, the pulses are active high. The default value for *PLS_INV* is zero, which selects active low pulses.

The WPULSE and VPULSE pulse generator outputs are available on pins DIO0/WPULSE and DIO1/VPULSE, respectively (pins 45 and 44). The pulses can also be output on OPT_TX pin 53 (see *OPT_TXE[1:0]*, *I/O RAM 0x2456[3:2]* for details).

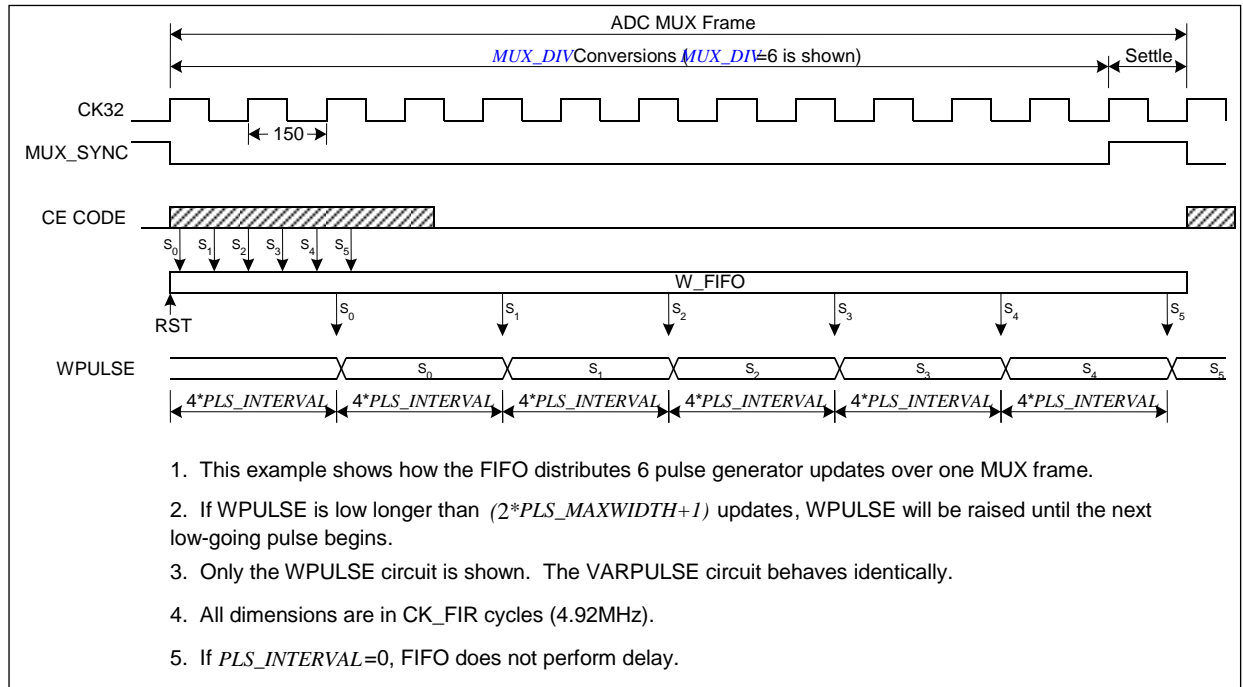

Figure 9. Pulse Generator FIFO Timing

2.3.7 CE Functional Overview

The ADC processes one sample per channel per multiplexer cycle. [Figure 10](#) shows the timing of the samples taken during one multiplexer cycle with $MUX_DIV[3:0] = 7$ (*I/O RAM 0x2100[7:4]*).

The number of samples processed during one accumulation cycle is controlled by the I/O RAM register $SUM_SAMPS[12:0]$ (*0x2107[4:0]* and *0x2108[7:0]*). The integration time for each energy output is:

$$SUM_SAMPS[12:0] / 2184.53, \text{ where } 2184.53 \text{ is the sample rate in Hz}$$

For example, $SUM_SAMPS[12:0] = 2184$ establishes 2184 multiplexer cycles per accumulation cycle or $2184/2184.53 = 0.9998$ seconds. After an accumulation cycle is completed, the XFER_BUSY interrupt signals to the MPU that accumulated data are available. The slight difference between the nominal length of the accumulation interval (1000 ms) and the actual length of 999.8 ms (0.025%) is accounted for in the CE code and is of no practical consequence.

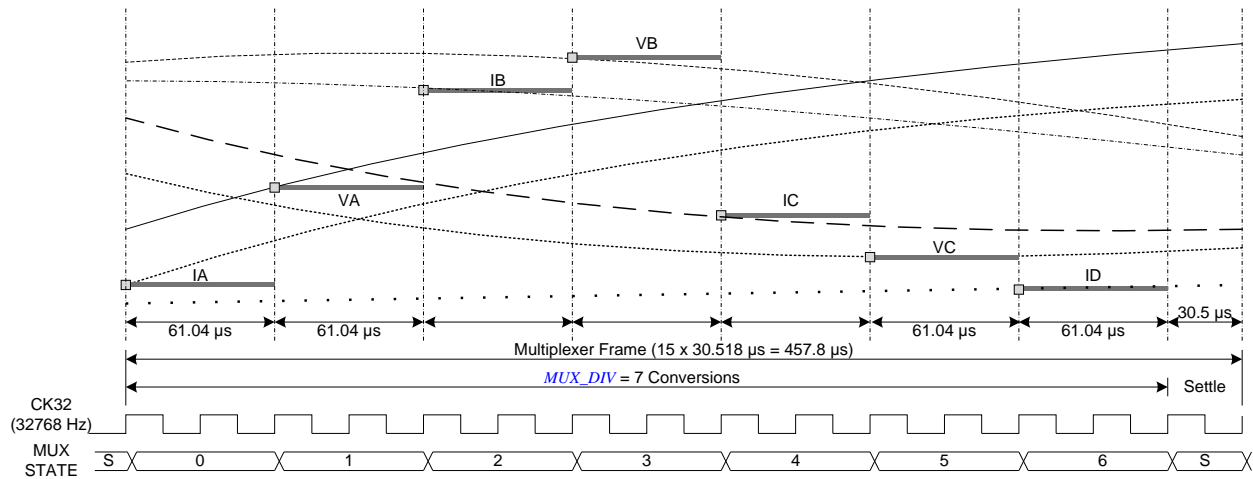

Figure 10: Samples from Multiplexer Cycle (Frame)

The end of each multiplexer cycle is signaled to the MPU by the CE_BUSY interrupt. At the end of each multiplexer cycle, status information, such as sag data and the digitized input signal, is available to the MPU.

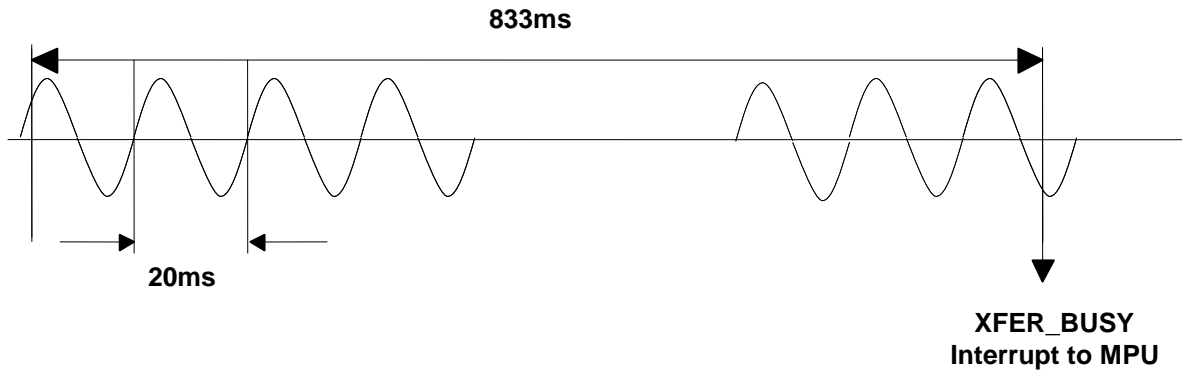

Figure 11: Accumulation Interval

Figure 11 shows the accumulation interval resulting from $SUM_SAMPS[12:0] = 1819$ (I/O RAM $0x2107[4:0]$ and $0x2108[7:0]$), consisting of 1819 samples of 457.8 μs each, followed by the XFER_BUSY interrupt. The sampling in this example is applied to a 50 Hz signal. There is no correlation between the line signal frequency and the choice of $SUM_SAMPS[12:0]$. Furthermore, sampling does not have to start when the line voltage crosses the zero line, and the length of the accumulation interval need not be an integer multiple of the signal cycles.

2.4 80515 MPU Core

2.4.1 MPU Setup Code

For the proper operation of the 71M6545/H, it is necessary to have a small MPU program in flash memory. In a typical application, the external host processor performs all post-processing and monitors and controls the 71M6545/H over its SPI slave interface. The following is a brief description of the tasks performed by the required setup code. The setup code correctly configures the 71M6545/H to act as an SPI Slave to a host processor, providing powerful AFE and 32-bit Metrology Processor functionality.

The main objective of the setup code is to keep the MPU code execution confined to a small area of Flash memory.

Most of the Flash memory space is empty, except for the small setup program and the CE code. When ac power failure occurs, the MPU sets the *SLEEP* bit (*I/O RAM 0x28B2[7]*) bit to force the device to SLP mode (see [3.2 SLP Mode \(Sleep Mode\)](#) on page 65).

SFR (Special Function Registers) access is needed for configuring and controlling the DIO0-DIO14 pins. The SFRs of the MPU cannot be accessed directly over the SPI Slave interface. If the host requires control of DIO0-DIO14, a small amount of code in the MPU provides the needed SFR access.

Triggering the WDT reset.

Controlling the 71M6xx3 Remote Sensor Interfaces, if used (temperature data for CE).

To speed up the start-up process and to offload the host processor, the small MPU program can implement the following optional steps at start-up:

- Copy CE data from flash to XRAM (default settings).
- Initialize the interrupt vector table.
- Initialize the pointer to the CE code location.
- Initialize the environmental settings for the CE code (multiplexer and filter settings, etc.)
- Start the ADC and CE.

It is also recommended that the small MPU program maintains a counter that is incremented with each *XFER_BUSY* interrupt. By reading this counter, the external host processor can determine if any accumulated metrology data were missed and if the 71M6545/H code is executing as expected.

Sample MPU code that performs these simple tasks is available from Silergy.

During normal operation, the host processor needs to trigger the watchdog reset periodically in order to avoid watchdog resets, if this is not done by the MPU program inside the 71M6545/H.

The remainder of this section provides detailed information concerning the MPU, and may be ignored if the application does not require the use of the MPU beyond the simple setup code tasks described.

2.4.2 80515 MPU Overview

The 71M6545/H includes an 80515 MPU (8-bit, 8051-compatible) that processes most instructions in one clock cycle. Using a 4.9 MHz clock results in a processing throughput of 4.9 MIPS. The 80515 architecture eliminates redundant bus states and implements parallel execution of fetch and execution phases. Normally, a machine cycle is aligned with a memory fetch, therefore, most of the 1-byte instructions are performed in a single machine cycle (MPU clock cycle). This leads to an 8x average performance improvement (in terms of MIPS) over the Intel 8051 device running at the same clock frequency.

Table 8 shows the CKMPU frequency as a function of the MCK clock (19.6608 MHz) divided by the MPU clock divider *MPU_DIV[2:0]* (*I/O RAM 0x2200[2:0]*). Actual processor clocking speed can be adjusted to the total processing demand of the application (metering calculations, AMR management, memory management and I/O management) using *MPU_DIV[2:0]*, as shown in [Table 8](#).

Table 8: CKMPU Clock Frequencies

<i>MPU_DIV</i> [2:0]	CKMPU Frequency
000	4.9152 MHz
001	2.4576 MHz
010	1.2288 MHz
011	614.4 kHz
100	307.2 kHz
101	
110	
111	

Typical measurement and metering functions based on the results provided by the internal 32-bit compute engine (CE) are available for the MPU as part of the Silergy demonstration code, which is provided to help reduce the product design cycle.

2.4.3 Memory Organization and Addressing

The 80515 MPU core incorporates the Harvard architecture with separate code and data spaces. Memory organization in the 80515 is similar to that of the industry standard 8051. There are three memory areas: Program memory (Flash, shared by MPU and CE), external RAM (Data RAM, shared by the CE and MPU, Configuration or I/O RAM), and internal data memory (Internal RAM). [Table 9](#) shows the memory map.

Program Memory

The 80515 can address up to 64 KB of program memory space (0x0000 to 0xFFFF). Program memory is read when the MPU fetches instructions or performs a MOVC operation.

After reset, the MPU starts program execution from program memory location 0x0000. The lower part of the program memory includes reset and interrupt vectors. The interrupt vectors are spaced at 8-byte intervals, starting from 0x0003.

MPU External Data Memory (XRAM)

Both internal and external memory is physically located on the 71M6545/H device. The external memory referred to in this documentation is only external to the 80515 MPU core.

5 KB of RAM starting at address 0x0000 is shared by the CE and MPU. The CE normally uses the first 1 KB, leaving 4 KB for the MPU. Different versions of the CE code use varying amounts. Consult the documentation for the specific code version being used for the exact limit.



If the MPU overwrites the CE's working RAM, the CE's output may be corrupted. If the CE is disabled, the first 0x40 bytes of RAM are still unusable while *MUX_DIV*[3:0] = 0 (I/O RAM 0x2100[7:3]), because the 71M6545/H ADC writes to these locations. Writing *MUX_DIV*[3:0] = 0 disables the ADC output, preventing the CE from writing the first 0x40 bytes of RAM.



To change the slot assignments established by *MUXn_SEL*[3:0], first set *MUX_DIV*[3:0] to zero, then change the *MUXn_SEL*[3:0] slot assignments, and finally set *MUX_DIV*[3:0] to the number of active MUX frame slots.

The 80515 writes into external data memory when the MPU executes a MOVX @Ri,A or MOVX @DPTR,A instruction. The MPU reads external data memory by executing a MOVX A,@Ri or MOVX A,@DPTR instruction (*PDATA*, *SFR* 0xBF, provides the upper 8 bytes for the MOVX A,@Ri instruction).

Internal and External Memory Map

Table 9 shows the address, type, use and size of the various memory components.

Table 9: Memory Map

Address (hex)	Memory Technology	Memory Type	Name	Typical Usage	Memory Size (bytes)
0000-FFFF	Flash Memory	Non-volatile	Program memory	MPU Program and non-volatile data	64 KB
				CE program (on 1 KB boundary)	3 KB max.
0000-13FF	Static RAM	Volatile	External RAM (XRAM)	Shared by CE and MPU	5 KB
2000-27FF	Static RAM	Volatile	Configuration RAM (I/O RAM)	Hardware control	2 KB
2800-287F	Static RAM	Non-volatile (battery)	Configuration RAM (I/O RAM)	Battery-buffered memory	128
0000-00FF	Static RAM	Volatile	Internal RAM	Part of 80515 Core	256

MOVX Addressing

There are two types of instructions differing in whether they provide an 8-bit or 16-bit indirect address to the external data RAM.

In the first type, `MOVX A,@Ri`, the contents of R0 or R1 in the current register bank provide the eight lower-ordered bits of address. The eight high-ordered bits of the address are specified with the *PDATA* SFR. This method allows the user paged access (256 pages of 256 bytes each) to all ranges of the external data RAM.

In the second type of MOVX instruction, `MOVX A,@DPTR`, the data pointer generates a 16-bit address. This form is faster and more efficient when accessing very large data arrays (up to 64 KB), since no additional instructions are needed to set up the eight high ordered bits of the address.

It is possible to mix the two MOVX types. This provides the user with four separate data pointers, two with direct access and two with paged access, to the entire 64 KB of external memory range.

Dual Data Pointer

The Dual Data Pointer accelerates the block moves of data. The standard *DPTR* is a 16-bit register that is used to address external memory or peripherals. In the 80515 core, the standard data pointer is called *DPTR*, the second data pointer is called *DPTR1*. The data pointer select bit, located in the LSB of the *DPS* register (*DPS*[0], *SFR 0x92*), chooses the active pointer. *DPTR* is selected when *DPS*[0] = 0 and *DPTR1* is selected when *DPS*[0] = 1.

The user switches between pointers by toggling the LSB of the *DPS* register. The values in the data pointers are not affected by the LSB of the *DPS* register. All *DPTR* related instructions use the currently selected *DPTR* for any activity.



The second data pointer may not be supported by certain compilers.



DPTR1 is useful for copy routines, where it can make the inner loop of the routine two instructions faster compared to the reloading of *DPTR* from registers. Any interrupt routine using *DPTR1* must save and restore *DPS*, *DPTR* and *DPTR1*, which increases stack usage and slows down interrupt latency.



By selecting the Evatronics R80515 core in the Keil compiler project settings and by using the compiler directive "MODC2", dual data pointers are enabled in certain library routines.

An alternative data pointer is available in the form of the *PDATA* register (*SFR 0xBF*), sometimes referred to as *USR2*). It defines the high byte of a 16-bit address when reading or writing *XDATA* with the instruction `MOVX A,@Ri` or `MOVX @Ri,A`.

Internal Data Memory Map and Access

The Internal data memory provides 256 bytes (0x00 to 0xFF) of data memory. The internal data memory address is always 1 byte wide. [Table 10](#) shows the internal data memory map.

The Special Function Registers (SFR) occupy the upper 128 bytes. The SFR area of internal data memory is available only by direct addressing. Indirect addressing of this area accesses the upper 128 bytes of Internal RAM. The lower 128 bytes contain working registers and bit addressable memory. The lower 32 bytes form four banks of eight registers (R0-R7). Two bits on the program memory status word (*PSW, SFR 0xD0*) select which bank is in use. The next 16 bytes form a block of bit addressable memory space at addresses 0x00-0x7F. All of the bytes in the lower 128 bytes are accessible through direct or indirect addressing.

Table 10: Internal Data Memory Map

Address Range		Direct Addressing	Indirect Addressing
0x80	0xFF	Special Function Registers (SFRs)	RAM
0x30	0x7F	Byte addressable area	
0x20	0x2F	Bit addressable area	
0x00	0x1F	Register banks R0...R7	

2.4.4 Special Function Registers (SFRs)

A map of the Special Function Registers is shown in [Table 11](#).

Only a few addresses in the SFR memory space are occupied, the others are not implemented. A read access to unimplemented addresses returns undefined data, while a write access has no effect. SFRs specific to the 71M6545/H are shown in **bold** print on a gray field. The registers at 0x80, 0x88, 0x90, etc., are bit addressable, all others are byte addressable.

Table 11: Special Function Register Map

Hex/ Bin	Bit Addressable	Byte Addressable							Bin/ Hex
	X000	X001	X010	X011	X100	X101	X110	X111	
F8	FLAG1	STAT			REMOTEO	SPI1			FF
F0	<i>B</i>								F7
E8	IFLAGS								EF
E0	<i>A</i>								E7
D8	<i>WDCON</i>								DF
D0	<i>PSW</i>								D7
C8	<i>T2CON</i>								CF
C0	<i>IRCON</i>								C7
B8	<i>IEN1</i>	<i>IP1</i>	<i>SORELH</i>	<i>SIRELH</i>				<i>PDATA</i>	BF
B0	P3		FLSHCTL					PGADR	B7
A8	<i>IEN0</i>	<i>IP0</i>	<i>SORELL</i>						AF
A0	P2	DIR2	DIR0						A7
98	<i>SOCON</i>	<i>S0BUF</i>	<i>IEN2</i>	<i>S1CON</i>	<i>S1BUF</i>	<i>SIRELL</i>	EEDATA	EECTRL	9F
90	P1	DIR1	<i>DPS</i>		ERASE				97
88	<i>TCON</i>	<i>TMOD</i>	<i>TL0</i>	<i>TL1</i>	<i>TH0</i>	<i>TH1</i>	<i>CKCON</i>		8F
80	<i>P0</i>	<i>SP</i>	<i>DPL</i>	<i>DPH</i>	<i>DPL1</i>	<i>DPH1</i>		<i>PCON</i>	87

2.4.5 Generic 80515 Special Function Registers

Table 12 shows the location, description and reset or power-up value of the generic 80515 SFRs. Additional descriptions of the registers can be found at the page numbers listed in the table.

Table 12: Generic 80515 SFRs - Location and Reset Values

Name	Address (Hex)	Reset value (Hex)	Description	Page(s)
<i>P0</i>	0x80	0xFF	Port 0	35
<i>SP</i>	0x81	0x07	Stack Pointer	34
<i>DPL</i>	0x82	0x00	Data Pointer Low 0	34
<i>DPH</i>	0x83	0x00	Data Pointer High 0	34
<i>DPL1</i>	0x84	0x00	Data Pointer Low 1	34
<i>DPH1</i>	0x85	0x00	Data Pointer High 1	34
<i>PCON</i>	0x87	0x00	UART Speed Control	37
<i>TCON</i>	0x88	0x00	Timer/Counter Control	40
<i>TMOD</i>	0x89	0x00	Timer Mode Control	38
<i>TL0</i>	0x8A	0x00	Timer 0, low byte	38
<i>TL1</i>	0x8B	0x00	Timer 1, high byte	38
<i>TH0</i>	0x8C	0x00	Timer 0, low byte	38
<i>TH1</i>	0x8D	0x00	Timer 1, high byte	38
<i>CKCON</i>	0x8E	0x01	Clock Control (Stretch=1)	35
<i>P1</i>	0x90	0xFF	Port 1	35
<i>DPS</i>	0x92	0x00	Data Pointer select Register	31
<i>SOCON</i>	0x98	0x00	Serial Port 0, Control Register	37
<i>SOBUF</i>	0x99	0x00	Serial Port 0, Data Buffer	35
<i>IEN2</i>	0x9A	0x00	Interrupt Enable Register 2	40
<i>SICON</i>	0x9B	0x00	Serial Port 1, Control Register	37
<i>SIBUF</i>	0x9C	0x00	Serial Port 1, Data Buffer	35
<i>SIRELL</i>	0x9D	0x00	Serial Port 1, Reload Register, low byte	35
<i>P2</i>	0xA0	0xFF	Port 2	35
<i>IEN0</i>	0xA8	0x00	Interrupt Enable Register 0	40
<i>IPO</i>	0xA9	0x00	Interrupt Priority Register 0	42
<i>SORELL</i>	0xAA	0xD9	Serial Port 0, Reload Register, low byte	35
<i>P3</i>	0xB0	0xFF	Port 3	35
<i>IEN1</i>	0xB8	0x00	Interrupt Enable Register 1	40
<i>IP1</i>	0xB9	0x00	Interrupt Priority Register 1	42
<i>SORELH</i>	0xBA	0x03	Serial Port 0, Reload Register, high byte	35
<i>SIRELH</i>	0xBB	0x03	Serial Port 1, Reload Register, high byte	35
<i>PDATA</i>	0xBF	0x00	High address byte for MOVX@Ri - also called <i>USR2</i>	31
<i>IRCON</i>	0xC0	0x00	Interrupt Request Control Register	41
<i>T2CON</i>	0xC8	0x00	Polarity for INT2 and INT3	41
<i>PSW</i>	0xD0	0x00	Program Status Word	34
<i>WDCON</i>	0xD8	0x00	Baud Rate Control Register (only WDCON[7] bit used)	35
<i>A</i>	0xE0	0x00	Accumulator	34
<i>B</i>	0xF0	0x00	B Register	34

Accumulator (ACC, A, SFR 0x E0):

ACC is the accumulator register. Most instructions use the accumulator to hold the operand. The mnemonics for accumulator-specific instructions refer to accumulator as A, not ACC.

B Register (SFR 0xF0):

The B register is used during multiply and divide instructions. It can also be used as a scratch-pad register to hold temporary data.

Program Status Word (PSW, SFR 0xD0):

This register contains various flags and control bits for the selection of the register banks (see Table 13).

Table 13: PSW Bit Functions (SFR 0xD0)

PSW Bit	Symbol	Function																
7	CV	Carry flag.																
6	AC	Auxiliary Carry flag for BCD operations.																
5	F0	General purpose Flag 0 available for user.  F0 is not to be confused with the F0 flag in the CESTATUS register.																
4	RSI	Register bank select control bits. The contents of RSI and RS0 select the working register bank:																
			<table border="1"> <thead> <tr> <th>RSI/RS0</th> <th>Bank selected</th> <th>Location</th> </tr> </thead> <tbody> <tr> <td>00</td> <td>Bank 0</td> <td>0x00 – 0x07</td> </tr> <tr> <td>01</td> <td>Bank 1</td> <td>0x08 – 0x0F</td> </tr> <tr> <td>10</td> <td>Bank 2</td> <td>0x10 – 0x17</td> </tr> <tr> <td>11</td> <td>Bank 3</td> <td>0x18 – 0x1F</td> </tr> </tbody> </table>	RSI/RS0	Bank selected	Location	00	Bank 0	0x00 – 0x07	01	Bank 1	0x08 – 0x0F	10	Bank 2	0x10 – 0x17	11	Bank 3	0x18 – 0x1F
RSI/RS0	Bank selected		Location															
00	Bank 0		0x00 – 0x07															
01	Bank 1		0x08 – 0x0F															
10	Bank 2	0x10 – 0x17																
11	Bank 3	0x18 – 0x1F																
3	RS0																	
2	OV	Overflow flag.																
1	–	User defined flag.																
0	P	Parity flag, affected by hardware to indicate odd or even number of one bits in the Accumulator, i.e. even parity.																

Stack Pointer (SP, SFR 0x81):

The stack pointer is a 1-byte register initialized to 0x07 after reset. This register is incremented before PUSH and CALL instructions, causing the stack to begin at location 0x08.

Data Pointer:

The data pointers (DPTR and DPRT1) are 2 bytes wide. The lower part is DPL (SFR 0x82) and DPL1 (SFR 0x84), respectively. The highest is DPH (SFR 0x83) and DPH1 (SFR 0x85), respectively. The data pointers can be loaded as two registers (e.g. MOV DPL,#data8). They are generally used to access external code or data space (e.g. MOV A,@A+DPTR or MOVX A,@DPTR respectively).

Program Counter:

The program counter (PC) is 2 bytes wide and initialized to 0x0000 after reset. This register is incremented when fetching operation code or when operating on data from program memory.

Port Registers:

DIO0 through DIO14 are controlled by Special Function Registers P0, P1, P2, and P3 as shown in Table 14. Above DIO14, the DIO[n] registers in I/O RAM are used. Since the direction bits are contained in the upper nibble of each SFR Pn register and the DIO bits are contained in the lower nibble, it is possible to configure the direction of a given DIO pin and set its output value with a single write operation, thus facilitating the implementation of bit-banged interfaces. Writing a 1 to a DIO_DIR bit configures the corresponding DIO as an output, while writing a 0 configures it as an input. Writing a 1 to a DIO bit causes the corresponding pin to be at high level (V3P3), while writing a 0 causes the corresponding pin to be held at a low level (GND).

Table 14: Port Registers (DIO0-14)

SFR Name	SFR Address	D7	D6	D5	D4	D3	D2	D1	D0
<i>P0</i>	80	<i>DIO_DIR[3:0]</i>				<i>DIO[3:0]</i>			
<i>P1</i>	90	<i>DIO_DIR[7:4]</i>				<i>DIO[7:4]</i>			
<i>P2</i>	A0	<i>DIO_DIR[11:8]</i>				<i>DIO[11:8]</i>			
<i>P3</i>	B0	<i>DIO_DIR[14:12]</i>				<i>DIO[14:11]</i>			

All DIO ports on the chip are bi-directional. Each of them consists of a latch (SFR *P0* to *P3*), an output driver and an input buffer, therefore the MPU can output or read data through any of these ports. Even if a DIO pin is configured as an output, the state of the pin can still be read by the MPU, for example when counting pulses issued via DIO pins that are under CE control.



At power-up DIO0-14 are configured as outputs, but the pins are in a high-impedance state because *PORT_E=0* (I/O RAM *0x270C[5]*). Host firmware should first configure DIO0-14 to the desired state, then set *PORT_E=1* to enable the function.

Clock Stretching (*CKCON[2:0]*, SFR *0x8E*)

The *CKCON[2:0]* field defines the stretch memory cycles that are used for MOVX instructions when accessing external peripherals. The practical value of this register for the 71M6545/H is to guarantee access to XRAM between CE, MPU, and SPI.

Table 15 shows how the signals of the External Memory Interface change when stretch values are set from 0 to 7. The widths of the signals are counted in MPU clock cycles. The post-reset state of the *CKCON[2:0]* field (001), which is shown in **bold** in the table, performs the MOVX instructions with a stretch value equal to 1.

Table 15: Stretch Memory Cycle Width

<i>CKCON[2:0]</i>	Stretch Value	Read Signal Width		Write Signal Width	
		memaddr	memrd	memaddr	memwr
000	0	1	1	2	1
001	1	2	2	3	1
010	2	3	3	4	2
011	3	4	4	5	3
100	4	5	5	6	4
101	5	6	6	7	5
110	6	7	7	8	6
111	7	8	8	9	7

2.4.6 Instruction Set

All instructions of the generic 8051 microcontroller are supported. A complete list of the instruction set and of the associated op-codes is contained in the *71M654x Software User's Guide (SUG)*.

2.4.7 UARTs

The 71M6545/H includes a UART (UART0) that can be programmed to communicate with a variety of AMR modules and other external devices.

The UART is a dedicated 2-wire serial interface, which can communicate with an external host processor at up to 38,400 bits/s (with MPU clock = 1.2288 MHz). The operation of the RX and TX UART0 pins is as follows:

UART0 RX: Serial input data are applied at this pin. Conforming to RS-232 standard, the bytes are input LSB first.

UART0 TX: This pin is used to output the serial data. The bytes are output LSB first.

The 71M6545/H has several UART-related registers for the control and buffering of serial data.

A single SFR register serves as both the transmit buffer and receive buffer (*SOBUF*, SFR 0x99 for UART0). When written by the MPU, *SxBUF* acts as the transmit buffer, and when read by the MPU, it acts as the receive buffer. Writing data to the transmit buffer starts the transmission by the UART. Received data are available by reading from the receive buffer. The UART can simultaneously transmit and receive data.

WDCON[7] (SFR 0xD8) selects whether timer 1 or the internal baud rate generator is used. All UART transfers are programmable for parity enable, parity, 2 stop bits/1 stop bit and XON/XOFF options for variable communication baud rates from 300 to 38400 bps. Table 16 shows how the baud rates are calculated. Table 17 shows the selectable UART operation modes.

Table 16: Baud Rate Generation

	Using Timer 1 (<i>WDCON[7]</i> = 0)	Using Internal Baud Rate Generator (<i>WDCON[7]</i> = 1)
UART0	$2^{\text{smod}} * f_{\text{CKMPU}} / (384 * (256 - \text{TH1}))$	$2^{\text{smod}} * f_{\text{CKMPU}} / (64 * (2^{10} - \text{SOREL}))$
UART1	N/A	$f_{\text{CKMPU}} / (32 * (2^{10} - \text{SIREL}))$

SOREL and *SIREL* are 10-bit values derived by combining bits from the respective timer reload registers. (*SORELL*, *SORELH*, *SIRELL*, *SIRELH* are SFR 0xAA, SFR 0xBA, SFR 0x9D and SFR 0xBB, respectively) *SMOD* is the *SMOD* bit in the SFR *PCON* register (SFR 0x87). *TH1* (SFR 0x8D) is the high byte of timer 1.

Table 17: UART Modes

	UART 0	UART 1
Mode 0	N/A	Start bit, 8 data bits, parity, stop bit, variable baud rate (internal baud rate generator)
Mode 1	Start bit, 8 data bits, stop bit, variable baud rate (internal baud rate generator or timer 1)	Start bit, 8 data bits, stop bit, variable baud rate (internal baud rate generator)
Mode 2	Start bit, 8 data bits, parity, stop bit, fixed baud rate 1/32 or 1/64 of f_{CKMPU}	N/A
Mode 3	Start bit, 8 data bits, parity, stop bit, variable baud rate (internal baud rate generator or timer 1)	N/A



Parity of serial data is available through the P flag of the accumulator. 7-bit serial modes with parity, such as those used by the FLAG protocol, can be simulated by setting and reading bit 7 of 8-bit output data. 7-bit serial modes without parity can be simulated by setting bit 7 to a constant 1. 8-bit serial modes with parity can be simulated by setting and reading the 9th bit, using the control bits *TB80* (*SOCON[3]*) and *TB81* (*SICON[3]*) in the *SOCON* (SFR 0x98) and *SICON* (SFR 0x9B) registers for transmit and *RB81* (*SICON[2]*) for receive operations.

All supported operation modes use oversampling for the incoming bit stream when receiving data. Each bit is sampled three times at the projected middle of the bit duration. This technique allows for deviations of the received baud rate from nominal of up to 3.5%.

The feature of receiving 9 bits (Mode 3 for UART0) can be used as handshake signals for inter-processor communication in multi-processor systems. In this case, the slave processors have bit *SM20* (*SOCON[5]*) for UART0, set to 1. When the master processor outputs the slave's address, it sets the 9th bit to 1, causing a serial port receive interrupt in all the slaves. The slave processors compare the received byte with their address. If there is a match, the addressed slave clears *SM20* or *SM21* and receive the rest of the message.

The rest of the slaves ignore the message. After addressing the slave, the host outputs the rest of the message with the 9th bit set to 0, so no additional serial port receive interrupts is generated.

UART Control Registers:

The functions of UART0 depend on the setting of the Serial Port Control Register *SOCON* shown in [Table 18](#), and the *PCON* register shown in [Table 19](#).



Since the *TIO* and *RIO* bits are in an SFR bit addressable byte, common practice would be to clear them with a bit operation, but this must be avoided. The hardware implements bit operations as a byte wide read-modify-write hardware macro. If an interrupt occurs after the read, but before the write, its flag is cleared unintentionally.

The proper way to clear these flag bits is to write a byte mask consisting of all ones except for a zero in the location of the bit to be cleared. The flag bits are configured in hardware to ignore ones written to them.

Table 18: The *SOCON* (UART0) Register (SFR 0x98)

Bit	Symbol	Function																					
<i>SOCON</i> [7]	<i>SM0</i>	The <i>SM0</i> and <i>SM1</i> bits set the UART0 mode:																					
<i>SOCON</i> [6]	<i>SM1</i>																						
			<table border="1"> <thead> <tr> <th>Mode</th> <th>Description</th> <th><i>SM0</i></th> <th><i>SM1</i></th> </tr> </thead> <tbody> <tr> <td>0</td> <td>N/A</td> <td>0</td> <td>0</td> </tr> <tr> <td>1</td> <td>8-bit UART</td> <td>0</td> <td>1</td> </tr> <tr> <td>2</td> <td>9-bit UART</td> <td>1</td> <td>0</td> </tr> <tr> <td>3</td> <td>9-bit UART</td> <td>1</td> <td>1</td> </tr> </tbody> </table>	Mode	Description	<i>SM0</i>	<i>SM1</i>	0	N/A	0	0	1	8-bit UART	0	1	2	9-bit UART	1	0	3	9-bit UART	1	1
Mode	Description		<i>SM0</i>	<i>SM1</i>																			
0	N/A	0	0																				
1	8-bit UART	0	1																				
2	9-bit UART	1	0																				
3	9-bit UART	1	1																				
<i>SOCON</i> [5]	<i>SM20</i>	Enables the inter-processor communication feature.																					
<i>SOCON</i> [4]	<i>RENO</i>	If set, enables serial reception. Cleared by software to disable reception.																					
<i>SOCON</i> [3]	<i>TB80</i>	The 9 th transmitted data bit in Modes 2 and 3. Set or cleared by the MPU, depending on the function it performs (parity check, multiprocessor communication etc.)																					
<i>SOCON</i> [2]	<i>RB80</i>	In Modes 2 and 3 it is the 9 th data bit received. In Mode 1, <i>SM20</i> is 0, <i>RB80</i> is the stop bit. In mode 0, this bit is not used. Must be cleared by software.																					
<i>SOCON</i> [1]	<i>TIO</i>	Transmit interrupt flag; set by hardware after completion of a serial transfer. Must be cleared by software (see Caution above).																					
<i>SOCON</i> [0]	<i>RIO</i>	Receive interrupt flag; set by hardware after completion of a serial reception. Must be cleared by software (see Caution above).																					

Table 19: *PCON* Register Bit Description (SFR 0x87)

Bit	Symbol	Function
<i>PCON</i> [7]	<i>SMOD</i>	The <i>SMOD</i> bit doubles the baud rate when set

2.4.8 Timers and Counters

The 80515 has two 16-bit timer/counter registers: Timer 0 and Timer 1. These registers can be configured for counter or timer operations.

In timer mode, the register is incremented every machine cycle, i.e., it counts up once for every 12 periods of the MPU clock. In counter mode, the register is incremented when the falling edge is observed at the corresponding input signal T0 or T1 (T0 and T1 are the timer gating inputs derived from certain DIO pins. Since it takes 2 machine cycles to recognize a 1-to-0 event, the maximum input count rate is 1/2 of the clock frequency (CKMPU). There are no restrictions on the duty cycle, however to ensure proper recognition of the 0 or 1 state, an input should be stable for at least 1 machine cycle.

Four operating modes can be selected for Timer 0 and Timer 1, as shown in [Table 20](#) and [Table 21](#). The *TMOD* (SFR 0x89) register, shown in [Table 22](#), is used to select the appropriate mode. The timer/counter operation is controlled by the *TCON* (SFR 0x88) register, which is shown in [Table 23](#). Bits *TR1* (*TCON*[6]) and *TR0* (*TCON*[4]) in the *TCON* register start their associated timers when set.

Table 20: Timers/Counters Mode Description

M1	M0	Mode	Function
0	0	Mode 0	13-bit Counter/Timer mode with 5 lower bits in the <i>TLO</i> or <i>TL1</i> (<i>SFR 0x8A</i> or <i>SFR 0x8B</i>) register and the remaining 8 bits in the <i>TH0</i> or <i>TH1</i> (<i>SFR 0x8C</i> or <i>SFR 0x8D</i>) register (for Timer 0 and Timer 1, respectively). The 3 high order bits of <i>TLO</i> and <i>TL1</i> are held at zero.
0	1	Mode 1	16-bit Counter/Timer mode.
1	0	Mode 2	8-bit auto-reload Counter/Timer. The reload value is kept in <i>TH0</i> or <i>TH1</i> , while <i>TLO</i> or <i>TL1</i> is incremented every machine cycle. When <i>TL(x)</i> overflows, a value from <i>TH(x)</i> is copied to <i>TL(x)</i> (where x is 0 for counter/timer 0 or 1 for counter/timer 1).
1	1	Mode 3	If Timer 1 <i>M1</i> and <i>M0</i> bits are set to 1, Timer 1 stops. If Timer 0 <i>M1</i> and <i>M0</i> bits are set to 1, Timer 0 acts as two independent 8-bit Timer/Counters.

✓ In Mode 3, *TLO* is affected by *TRO* and gate control bits, and sets the *TF0* flag on overflow, while *TH0* is affected by the *TR1* bit, and the *TF1* flag is set on overflow. [Table 21](#) specifies the combinations of operation modes allowed for Timer 0 and Timer 1.

Table 21: Allowed Timer/Counter Mode Combinations

	Timer 1		
	Mode 0	Mode 1	Mode 2
Timer 0 - mode 0	Yes	Yes	Yes
Timer 0 - mode 1	Yes	Yes	Yes
Timer 0 - mode 2	Not allowed	Not allowed	Yes

Table 22: *TMOD* Register Bit Description (*SFR 0x89*)

Bit	Symbol	Function
Timer/Counter 0:		
<i>TMOD</i> [7]	<i>Gate</i>	If <i>TMOD</i> [7] is set, external input signal control is enabled for Counter 0. The <i>TRO</i> bit in the <i>TCON</i> register (<i>SFR 0x88</i>) must also be set in order for Counter 0 to increment. With these settings, Counter 0 increments on every falling edge of the logic signal applied to one or more of the <i>DIO2-11</i> pins, as specified by the contents of the <i>DIO_R2</i> through <i>DIO_R11</i> registers. See Table 47 .
<i>TMOD</i> [6]	<i>C/T</i>	Selects timer or counter operation. When set to 1, a counter operation is performed. When cleared to 0, the corresponding register functions as a timer.
<i>TMOD</i> [5:4]	<i>M1:M0</i>	Selects the mode for Timer/Counter 0 as shown in Table 20 .
Timer/Counter 1		
<i>TMOD</i> [3]	<i>Gate</i>	If <i>TMOD</i> [3] is set, external input signal control is enabled for Counter 1. The <i>TR1</i> bit in the <i>TCON</i> register (<i>SFR 0x88</i>) must also be set in order for Counter 1 to increment. With these settings, Counter 1 increments on every falling edge of the logic signal applied to one or more of the <i>DIO2-11</i> pins, as specified by the contents of the <i>DIO_R2</i> through <i>DIO_R11</i> registers. See Table 47 .
<i>TMOD</i> [2]	<i>C/T</i>	Selects timer or counter operation. When set to 1, a counter operation is performed. When cleared to 0, the corresponding register functions as a timer.
<i>TMOD</i> [1:0]	<i>M1:M0</i>	Selects the mode for Timer/Counter 1, as shown in Table 20 .

Table 23: The TCON Register Bit Functions (SFR 0x88)

Bit	Symbol	Function
<i>TCON[7]</i>	<i>TF1</i>	The Timer 1 overflow flag is set by hardware when Timer 1 overflows. This flag can be cleared by software and is automatically cleared when an interrupt is processed.
<i>TCON[6]</i>	<i>TR1</i>	Timer 1 run control bit. If cleared, Timer 1 stops.
<i>TCON[5]</i>	<i>TF0</i>	Timer 0 overflow flag set by hardware when Timer 0 overflows. This flag can be cleared by software and is automatically cleared when an interrupt is processed.
<i>TCON[4]</i>	<i>TRO</i>	Timer 0 Run control bit. If cleared, Timer 0 stops.
<i>TCON[3]</i>	<i>IE1</i>	Interrupt 1 edge flag is set by hardware when the falling edge on external pin int1 is observed. Cleared when an interrupt is processed.
<i>TCON[2]</i>	<i>IT1</i>	Interrupt 1 type control bit. Selects either the falling edge or low level on input pin to cause an interrupt.
<i>TCON[1]</i>	<i>IE0</i>	Interrupt 0 edge flag is set by hardware when the falling edge on external pin int0 is observed. Cleared when an interrupt is processed.
<i>TCON[0]</i>	<i>IT0</i>	Interrupt 0 type control bit. Selects either the falling edge or low level on input pin to cause interrupt.

2.4.9 WD Timer (Software Watchdog Timer)

There is no internal software watchdog timer. Use the standard hardware watchdog timer instead (see [2.5.13 Hardware Watchdog Timer](#)).

2.4.10 Interrupts

The 80515 provides 11 interrupt sources with four priority levels. Each source has its own interrupt request flag(s) located in a special function register (*TCON*, *IRCON*, and *SCON*). Each interrupt requested by the corresponding flag can be individually enabled or disabled by the enable bits in *IEN0* (*SFR 0xA8*), *IEN1* (*SFR 0xB8*), and *IEN2* (*SFR 0x9A*). [Figure 12](#) shows the device interrupt structure.

Referring to [Figure 12](#), interrupt sources can originate from within the 80515 MPU core (referred to as Internal Sources) or can originate from other parts of the 71M6545/H Metrology Processor (referred to as External Sources). There are seven external interrupt sources, as seen in the leftmost part of [Figure 12](#), and in [Table 24](#) and [Table 25](#) (i.e., *EX0-EX6*).

Interrupt Overview

When an interrupt occurs, the MPU vectors to the predetermined address as shown in [Table 36](#). Once the interrupt service has begun, it can be interrupted only by a higher priority interrupt. The interrupt service is terminated by a return from instruction, RETI. When an RETI is performed, the processor returns to the instruction that would have been next when the interrupt occurred.

When the interrupt condition occurs, the processor also indicates this by setting a flag bit. This bit is set regardless of whether the interrupt is enabled or disabled. Each interrupt flag is sampled once per machine cycle, then samples are polled by the hardware. If the sample indicates a pending interrupt when the interrupt is enabled, then the interrupt request flag is set. On the next instruction cycle, the interrupt is acknowledged by hardware forcing an LCALL to the appropriate vector address, if the following conditions are met:

- No interrupt of equal or higher priority is already in progress.
- An instruction is currently being executed and is not completed.
- The instruction in progress is not RETI or any write access to the registers *IEN0*, *IEN1*, *IEN2*, *IPO* or *IP1*.

Special Function Registers for Interrupts

The following SFR registers control the interrupt functions:

- The interrupt enable registers: *IEN0*, *IEN1* and *IEN2* (see [Table 24](#), [Table 25](#) and [Table 26](#)).
- The Timer/Counter control registers, *TCON* and *T2CON* (see [Table 27](#) and [Table 28](#)).

The interrupt request register, *IRCON* (see [Table 29](#)).

The interrupt priority registers: *IPO* and *IP1* (see [Table 34](#)).

Table 24: The *IEN0* Bit Functions (SFR 0xA8)

Bit	Symbol	Function
<i>IEN0</i> [7]	<i>EAL</i>	<i>EAL</i> = 0 disables all interrupts.
<i>IEN0</i> [6]	–	Not used.
<i>IEN0</i> [5]	–	Not Used.
<i>IEN0</i> [4]	<i>ES0</i>	<i>ES0</i> = 0 disables serial channel 0 interrupt.
<i>IEN0</i> [3]	<i>ET1</i>	<i>ET1</i> = 0 disables timer 1 overflow interrupt.
<i>IEN0</i> [2]	<i>EX1</i>	<i>EX1</i> = 0 disables external interrupt 1.
<i>IEN0</i> [1]	<i>ET0</i>	<i>ET0</i> = 0 disables timer 0 overflow interrupt.
<i>IEN0</i> [0]	<i>EX0</i>	<i>EX0</i> = 0 disables external interrupt 0.

Table 25: The *IEN1* Bit Functions (SFR 0xB8)

Bit	Symbol	Function
<i>IEN1</i> [7]	–	Not used.
<i>IEN1</i> [6]	–	Not used.
<i>IEN1</i> [5]	<i>EX6</i>	<i>EX6</i> = 0 disables external interrupt 6.
<i>IEN1</i> [4]	<i>EX5</i>	<i>EX5</i> = 0 disables external interrupt 5.
<i>IEN1</i> [3]	<i>EX4</i>	<i>EX4</i> = 0 disables external interrupt 4.
<i>IEN1</i> [2]	<i>EX3</i>	<i>EX3</i> = 0 disables external interrupt 3.
<i>IEN1</i> [1]	<i>EX2</i>	<i>EX2</i> = 0 disables external interrupt 2.
<i>IEN1</i> [0]	–	Not Used.

Table 26: The *IEN2* Bit Functions (SFR 0x9A)

Bit	Symbol	Function
<i>IEN2</i> [0]	<i>ES1</i>	<i>ES1</i> = 0 disables the serial channel 1 interrupt.

Table 27: *TCON* Bit Functions (SFR 0x88)

Bit	Symbol	Function
<i>TCON</i> [7]	<i>TF1</i>	Timer 1 overflow flag.
<i>TCON</i> [6]	<i>TR1</i>	Not used for interrupt control.
<i>TCON</i> [5]	<i>TF0</i>	Timer 0 overflow flag.
<i>TCON</i> [4]	<i>TR0</i>	Not used for interrupt control.
<i>TCON</i> [3]	<i>IE1</i>	External interrupt 1 flag.
<i>TCON</i> [2]	<i>IT1</i>	External interrupt 1 type control bit: 0 = interrupt on low level. 1 = interrupt on falling edge.
<i>TCON</i> [1]	<i>IE0</i>	External interrupt 0 flag
<i>TCON</i> [0]	<i>IT0</i>	External interrupt 0 type control bit: 0 = interrupt on low level. 1 = interrupt on falling edge.

Table 28: The T2CON Bit Functions (SFR 0xC8)

Bit	Symbol	Function
T2CON[7]	–	Not used.
T2CON[6]	I3FR	Polarity control for INT3: 0 = falling edge. 1 = rising edge.
T2CON[5]	I2FR	Polarity control for INT2: 0 = falling edge. 1 = rising edge.
T2CON[4:0]	–	Not used.

Table 29: The IRCON Bit Functions (SFR 0xC0)

Bit	Symbol	Function
IRCON[7]	–	Not used
IRCON[6]	–	Not used
IRCON[5]	IEX6	1 = External interrupt 6 flag.
IRCON[4]	IEX5	1 = External interrupt 5 flag.
IRCON[3]	IEX4	1 = External interrupt 4 flag.
IRCON[2]	IEX3	1 = External interrupt 3 flag.
IRCON[1]	IEX2	1 = External interrupt 2 flag.
IRCON[0]	–	Not used.



TF0 and TF1 (Timer 0 and Timer 1 overflow flags) is automatically cleared by hardware when the service routine is called (Signals T0ACK and T1ACK – port ISR – active high when the service routine is called). IE0, IE1 and IEX2-IEX6 are cleared automatically when hardware causes execution to vector to the interrupt service routine.

External MPU Interrupts

The seven external interrupts are the interrupts external to the 80515 core, i.e. signals that originate in other parts of the 71M6545/H, for example the CE, DIO, RTC, or EEPROM interface.

The external interrupts are connected as shown in [Table 30](#). The polarity of interrupts 2 and 3 is programmable in the MPU via the I3FR and I2FR bits in T2CON (SFR 0xC8). Interrupts 2 and 3 should be programmed for falling sensitivity (I3FR = I2FR = 0). The generic 8051 MPU literature states that interrupts 4 through 6 are defined as rising-edge sensitive. Thus, the hardware signals attached to interrupts 5 and 6 are inverted to achieve the edge polarity shown in [Table 30](#).

Table 30: External MPU Interrupts

External Interrupt	Connection	Polarity	Flag Reset
0	Digital I/O (IE0)		automatic
1	Digital I/O (IE1)		automatic
2	CE_PULSE (IE_XPULSE, IE_YPULSE, IE_WPULSE, IE_VPULSE)	rising	manual
3	CE_BUSY (IE3)	falling	automatic
4	VSTAT (VSTAT[2:0] changed) (IE4)	rising	automatic
5	EEPROM busy (falling), SPI (rising) (IE_EEX, IE_SPI)	–	manual
6	XFER_BUSY (falling), RTC_1SEC, RTC_1MIN, RTC_T (IE_XFER, IE_RTC1S, IE_RTC1M, IE_RTCT)	falling	manual

External interrupt 0 and 1 can be mapped to pins on the device using DIO resource maps.

SFR enable bits must be set to permit any of these interrupts to occur. Likewise, each interrupt has its own flag bit, which is set by the interrupt hardware, and reset by the MPU interrupt handler. XFER_BUSY, RTC_1SEC, RTC_1MIN, RTC_T, SPI, PLLRISE and PLLFALL have their own enable and flag bits in addition to the interrupt 6, 4 and enable and flag bits (see [Table 31: Interrupt Enable and Flag Bits](#)).



IE0 through IEX6 are cleared automatically when the hardware vectors to the interrupt handler. The other flags, IE_XFER through IE_PB, are cleared by writing a zero to them.

Since these bits are in an SFR bit addressable byte, common practice would be to clear them with a bit operation, but this must be avoided. The hardware implements bit operations as a byte wide read-modify-write hardware macro. If an interrupt occurs after the read, but before the write, its flag is cleared unintentionally.

The proper way to clear the flag bits is to write a byte mask consisting of all ones except for a zero in the location of the bit to be cleared. The flag bits are configured in hardware to ignore ones written to them.

Table 31: Interrupt Enable and Flag Bits

Interrupt Enable		Interrupt Flag		Interrupt Description
Name	Location	Name	Location	
EX0	SFR A8[0]	IE0	SFR 88[1]	External interrupt 0
EX1	SFR A8[2]	IE1	SFR 88[3]	External interrupt 1
EX2	SFR B8[1]	IEX2	SFR C0[1]	External interrupt 2
EX3	SFR B8[2]	IEX3	SFR C0[2]	External interrupt 3
EX4	SFR B8[3]	IEX4	SFR C0[3]	External interrupt 4
EX5	SFR B8[4]	IEX5	SFR C0[4]	External interrupt 5
EX6	SFR B8[5]	IEX6	SFR C0[5]	External interrupt 6
EX_XFER	2700[0]	IE_XFER	SFR E8[0]	XFER_BUSY interrupt (int 6)
EX_RTC1S	2700[1]	IE_RTC1S	SFR E8[1]	RTC_1SEC interrupt (int 6)
EX_RTC1M	2700[2]	IE_RTC1M	SFR E8[2]	RTC_1MIN interrupt (int 6)
EX_RTCT	2700[4]	IE_RTCT	SFR E8[4]	RTC_T interrupt (int 6)
EX_SPI	2701[7]	IE_SPI	SFR F8[7]	SPI interrupt
EX_EEX	2700[7]	IE_EEX	SFR E8[7]	EEPROM interrupt
EX_XPULSE	2700[6]	IE_XPULSE	SFR E8[6]	CE_Xpulse interrupt (int 2)
EX_YPULSE	2700[5]	IE_YPULSE	SFR E8[5]	CE_Ypulse interrupt (int 2)
EX_WPULSE	2701[6]	IE_WPULSE	SFR F8[6]	CE_Wpulse interrupt (int 2)
EX_VPULSE	2701[5]	IE_VPULSE	SFR F8[5]	CE_Vpulse interrupt (int 2)

Interrupt Priority Level Structure

All interrupt sources are combined in groups, as shown in [Table 32](#).

Table 32: Interrupt Priority Level Groups

Group	Group Members	
0	External interrupt 0	Serial channel 1 interrupt
1	Timer 0 interrupt	External interrupt 2
2	External interrupt 1	External interrupt 3
3	Timer 1 interrupt	External interrupt 4
4	Serial channel 0 interrupt	External interrupt 5
5	–	External interrupt 6

Each group of interrupt sources can be programmed individually to one of four priority levels (as shown in [Table 33](#)) by setting or clearing one bit in the SFR interrupt priority register *IPO* (SFR 0xA9) and one in

IP1 (SFR 0xB9) (Table 34). If requests of the same priority level are received simultaneously, an internal polling sequence as shown in Table 35 determines which request is serviced first.

- ✓ Changing interrupt priorities while interrupts are enabled can easily cause software defects. It is best to set the interrupt priority registers only once during initialization before interrupts are enabled.

Table 33: Interrupt Priority Levels

<i>IP1</i> [x]	<i>IP0</i> [x]	Priority Level
0	0	Level 0 (lowest)
0	1	Level 1
1	0	Level 2
1	1	Level 3 (highest)

Table 34: Interrupt Priority Registers (*IP0* and *IP1*)

Register	Address	Bit 7 (MSB)	Bit 6	Bit 5	Bit 4	Bit 3	Bit 2	Bit 1	Bit 0 (LSB)
<i>IP0</i>	SFR 0xA9	–	–	<i>IP0</i> [5]	<i>IP0</i> [4]	<i>IP0</i> [3]	<i>IP0</i> [2]	<i>IP0</i> [1]	<i>IP0</i> [0]
<i>IP1</i>	SFR 0xB9	–	–	<i>IP1</i> [5]	<i>IP1</i> [4]	<i>IP1</i> [3]	<i>IP1</i> [2]	<i>IP1</i> [1]	<i>IP1</i> [0]

Table 35: Interrupt Polling Sequence

External interrupt 0	↓ Polling sequence ↓
Serial channel 1 interrupt	
Timer 0 interrupt	
External interrupt 2	
External interrupt 1	
External interrupt 3	
Timer 1 interrupt	
External interrupt 4	
Serial channel 0 interrupt	
External interrupt 5	
External interrupt 6	

Interrupt Sources and Vectors

Table 36 shows the interrupts with their associated flags and vector addresses.

Table 36: Interrupt Vectors

Interrupt Request Flag	Description	Interrupt Vector Address
<i>IE0</i>	External interrupt 0	0x0003
<i>TF0</i>	Timer 0 interrupt	0x000B
<i>IE1</i>	External interrupt 1	0x0013
<i>TF1</i>	Timer 1 interrupt	0x001B
<i>RI0/TI0</i>	Serial channel 0 interrupt	0x0023
<i>RI1/TI1</i>	Serial channel 1 interrupt	0x0083
<i>IEX2</i>	External interrupt 2	0x004B
<i>IEX3</i>	External interrupt 3	0x0053
<i>IEX4</i>	External interrupt 4	0x005B
<i>IEX5</i>	External interrupt 5	0x0063
<i>IEX6</i>	External interrupt 6	0x006B

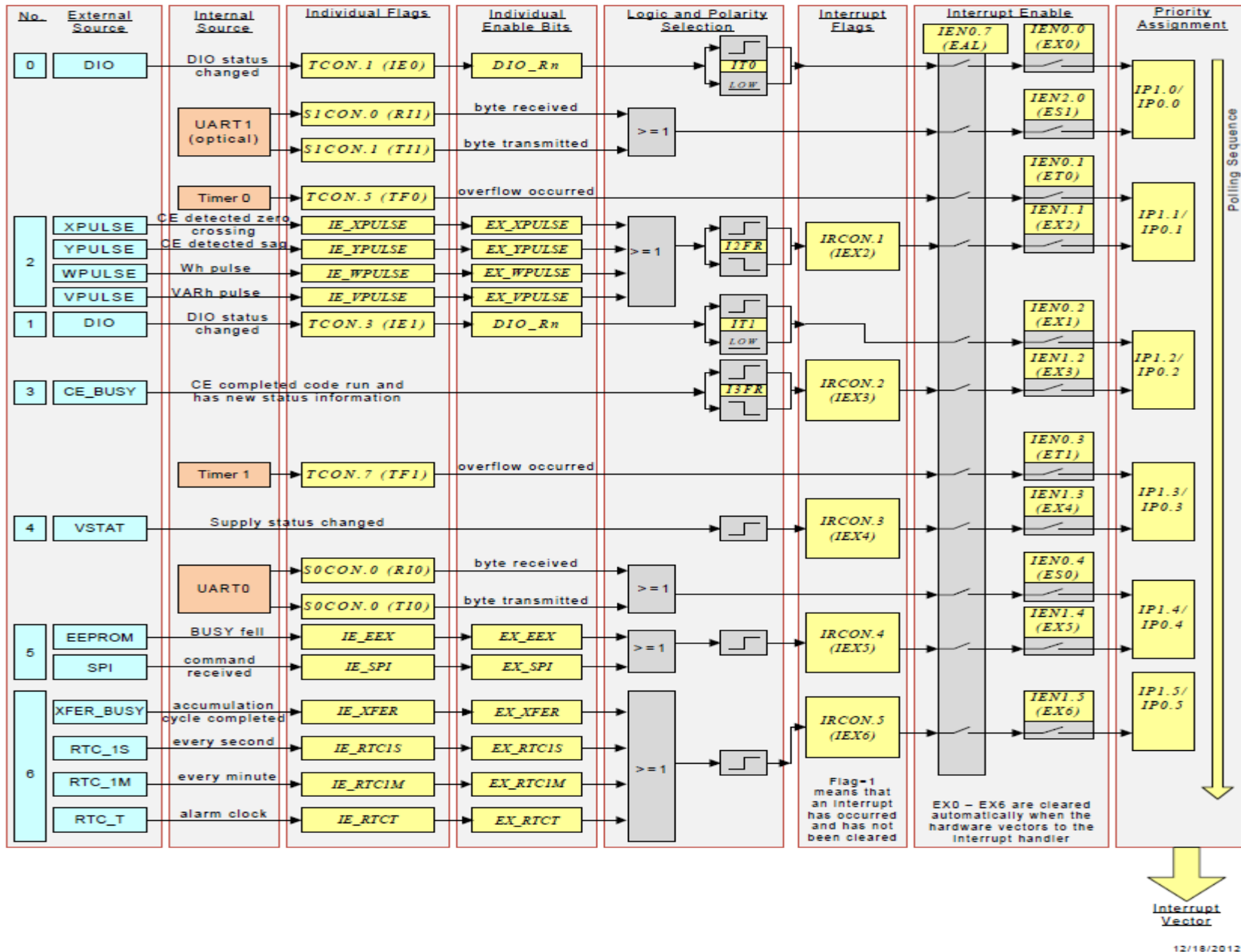

Figure 12: Interrupt Structure

2.5 On-Chip Resources

2.5.1 Physical Memory

2.5.1.1 Flash Memory

The 71M6545/H includes 64 KB of on-chip flash memory. The flash memory primarily contains MPU and CE program code. It also contains images of the CE RAM and I/O RAM. On power-up, before enabling the CE, the MPU copies these images to their respective locations.

Flash space allocated for the CE program is limited to 4096 16-bit words (8 KB). The CE program must begin on a 1-KB boundary of the flash address space. The *CE_LCTN[5:0]* (*I/O RAM 0x2109[5:0]*) field defines which 1-KB boundary contains the CE code. Thus, the first CE instruction is located at $1024 * CE_LCTN[5:0]$.

Flash memory can be accessed by the MPU, the CE, and by the SPI interface (R/W).

Table 37: Flash Memory Access

Access by	Access Type	Condition
MPU	R/W/E	W/E only if CE is disabled.
CE	R	
SPI	R/W/E	Access only when SFM is invoked (MPU halted).

Flash Write Procedures

If the *FLSH_UNLOCK[3:0]* (*I/O RAM 0x2702[7:4]*) key is correctly programmed, the MPU may write to the flash memory. This is one of the non-volatile storage options available to the user in addition to external EEPROM.

The flash program write enable bit, *FLSH_PSTWR* (*SFR 0xB2[0]*), differentiates 80515 data store instructions (MOVX@DPTR,A) between Flash and XRAM writes. This bit is automatically cleared by hardware after each byte write operation. Write operations to this bit are inhibited when interrupts are enabled.

If the CE is enabled (*CE_E = 1*, *I/O RAM 0x2106[0]*), flash write operations must not be attempted unless *FLSH_PSTWR* is set. This bit enables the “posted flash write” capability. *FLSH_PSTWR* has no effect when *CE_E = 0*. When *CE_E = 1*, however, *FLSH_PSTWR* delays a flash write until the time interval between the CE code passes. During this delay time, the *FLSH_PEND* (*SFR 0xB2[3]*) bit is high, and the MPU continues to execute commands. When the CE code pass ends (*CE_BUSY* falls), the *FLSH_PEND* bit falls and the write operation occurs. The MPU can query the *FLSH_PEND* bit to determine when the write operation has been completed. While *FLSH_PEND = 1*, further flash write requests are ignored.

Updating Individual Bytes in Flash Memory

The original state of a flash byte is 0xFF (all bits are 1). Once a value other than 0xFF is written to a flash memory cell, overwriting with a different value usually requires that the cell be erased first. Since cells cannot be erased individually, the page has to be first copied to RAM, followed by a page erase. After this, the page can be updated in RAM and then written back to the flash memory.

Flash Erase Procedures

Flash erasure is initiated by writing a specific data pattern to specific SFR registers in the proper sequence. These special pattern/sequence requirements prevent inadvertent erasure of the flash memory.

The mass erase sequence is:

Write 1 to the *FLSH_MEEN* bit (*SFR 0xB2[1]*).

Write the pattern 0xAA to the *FLSH_ERASE* (*SFR 0x94*) register.



The mass erase cycle can only be initiated when the ICE port is enabled.

The page erase sequence is:

Write the page address to *FLSH_PGADR[6:0]* (*SFR 0xB7[7:1]*).

Write the pattern 0x55 to the *FLSH_ERASE* register (*SFR 0x94*).

Program Security

When enabled, the security feature limits the ICE to global flash erase operations only. All other ICE operations, such as reading via the SPI or ICE port, are blocked. This guarantees the security of the user's MPU and CE program code. Security is enabled by MPU code that is executed in a 64 CKMPU cycle pre-boot interval before the primary boot sequence begins. Once security is enabled, the only way to disable it is to perform a global erase of the flash, followed by a chip reset.

The first 64 cycles of the MPU boot code are called the pre-boot phase because during this phase the ICE is inhibited. A read-only status bit, *PREBOOT* (*SFR 0xB2[7]*), identifies these cycles to the MPU. Upon completion of pre-boot, the ICE can be enabled and is permitted to take control of the MPU.

The security enable bit, *SECURE* (*SFR 0xB2[6]*), is reset whenever the chip is reset. Hardware associated with the bit allows only ones to be written to it. Thus, pre-boot code may set *SECURE* to enable the security feature but may not reset it. Once *SECURE* is set, the pre-boot and CE code are protected from erasure, and no external read of program code is possible.

Specifically, when the *SECURE* bit is set, the following applies:

The ICE is limited to bulk flash erase only.

Page zero of flash memory, the preferred location for the user's pre-boot code, may not be page-erased by either MPU or ICE. Page zero may only be erased with global flash erase.

Write operations to page zero, whether by MPU or ICE are inhibited.

The 71M6545/H also includes hardware to protect against unintentional Flash write and erase. To enable flash write and erase operations, a 4-bit hardware key that must be written to the *FLSH_UNLOCK[3:0]* field. The key is the binary number '0010'. If *FLSH_UNLOCK[3:0]* is not '0010', the Flash erase and write operation is inhibited by hardware. Proper operation of this security key requires that there be no firmware function that writes '0010' to *FLSH_UNLOCK[3:0]*. The key should be written by the external SPI master, in the case of SPI flash programming (SFM mode), or through the ICE interface in the case of ICE flash programming. When a boot loader is used, the key should be sent to the boot load code which then writes it to *FLSH_UNLOCK[3:0]*. *FLSH_UNLOCK[3:0]* is not automatically reset. It should be cleared when the SPI or ICE has finished changing the Flash. [Table 38](#) summarizes the I/O RAM registers used for flash security.

Table 38: Flash Security

Name	Location	Rst	Wk	Dir	Description
<i>FLSH_UNLOCK[3:0]</i>	2702[7:4]	0	0	R/W	Must be a 2 to enable any flash modification. See the description of Flash security for more details.
<i>SECURE</i>	SFR B2[6]	0	0	R/W	Inhibits erasure of page 0 and flash addresses above the beginning of CE code as defined by <i>CE_LCTN[5:0]</i> (<i>I/O RAM 0x2109[5:0]</i>). Also inhibits the read of flash via the ICE and SPI ports.

SPI Flash Mode

In normal operation, the SPI slave interface cannot read or write the flash memory. However, the 71M6545/H contains a Special Flash Mode (SFM) that facilitates initial (production) programming of the flash memory. When the 71M6545/H is in SFM mode, the SPI interface can erase, read, and write the flash. Other memory elements such as XRAM and I/O RAM are not accessible to the SPI in this mode. In order to protect the flash contents, several operations are required before the SFM mode is successfully invoked.

If the SPI port is used for code updates (in lieu of a programmer that uses the ICE port), then a code that disables the flash access via SPI can potentially lock out flash program updates. Details on the SFM can be found in [2.5.12 SPI Slave Port](#).

2.5.1.2 MPU/CE RAM

The 71M6545/H includes 5 KB of static RAM memory on-chip (XRAM) plus 256 bytes of internal RAM in the MPU core. The 5KB of static RAM are used for data storage by both MPU and CE and for the communication between MPU and CE.

2.5.1.3 I/O RAM (Configuration RAM)

The I/O RAM can be seen as a series of hardware registers that control basic hardware functions. I/O RAM address space starts at 0x2000. The registers of the I/O RAM are listed in [Table 59](#).

The 71M6545/H includes 128 bytes non-volatile RAM memory on-chip in the I/O RAM address space (addresses 0x2800 to 0x287F). This memory section is supported by the voltage applied at VBAT_RTC, and the data in it are preserved in SLP mode provided that the voltage at the VBAT_RTC pin is within specification.

2.5.2 Oscillator

The 71M6545/H oscillator drives a standard 32.768 kHz watch crystal. This type of crystal is accurate and does not require a high-current oscillator circuit. The oscillator has been designed specifically to handle watch crystals and is compatible with their high impedance and limited power handling capability. The oscillator power dissipation is very low to maximize the lifetime of any battery attached to VBAT_RTC.

Oscillator calibration can improve the accuracy of both the RTC and metering. Refer to [2.5.4, Real-Time Clock \(RTC\)](#) for more information.

The oscillator is powered from the V3P3SYS pin or from the VBAT_RTC pin, depending on the *V3OK* internal bit (i.e., $V3OK = 1$ if $V3P3SYS \geq 2.8$ VDC and $V3OK = 0$ if $V3P3SYS < 2.8$ VDC). The oscillator requires approximately 100 nA, which is negligible compared to the internal leakage of a battery.

- ✓ If VBAT_RTC is connected to a drained battery or disconnected, a battery test that sets *TEMP_BAT* may drain the supply connected to VBAT_RTC and cause the oscillator to stop. A stopped oscillator may force the device to reset. Therefore, an unexpected reset during a battery test should be interpreted as a battery failure.

2.5.3 PLL and Internal Clocks

Timing for the device is derived from the 32.768 kHz crystal oscillator output that is multiplied by a PLL by 600 to obtain 19.660800 MHz, the master clock (MCK). All on-chip timing, except for the RTC clock, is derived from MCK. [Table 39](#) provides a summary of the clock functions and their controls.

The two general-purpose counter/timers contained in the MPU are controlled by CKMPU (see [2.4.8 Timers and Counters](#)).

The master clock can be boosted to 19.66 MHz by setting the *PLL_FAST* bit = 1 (*I/O RAM 0x2200[4]*) and can be reduced to 6.29 MHz by *PLL_FAST* = 0. The MPU clock frequency CKMPU is determined by another divider controlled by the I/O RAM control field *MPU_DIV[2:0]* (*I/O RAM 0x2200[2:0]*) and can be set to $MCK * 2^{-(MPU_DIV+2)}$ where *MPU_DIV[2:0]* may vary from 0 to 4. When the ICE_E pin is high, the circuit also generates the 9.83 MHz clock for use by the emulator.

When the part is waking up from SLP mode, the PLL is turned on in 6.29 MHz mode, and the PLL frequency is not accurate until the *PLL_OK* (*SFR 0xF9[4]*) flag rises. Due to potential overshoot, the MPU should not change the value of *PLL_FAST* until *PLL_OK* is true.

Table 39: Clock System Summary

Clock	Derived From	Fixed Frequency or Range			Function
		<i>PLL_FAST=1</i>	<i>PLL_FAST=0</i>	Controlled by	
OSC	Crystal	32.768 kHz		–	Crystal clock
MCK	Crystal/PLL	19.660800 MHz (600*CK32)	6.291456 MHz (192*CK32)	<i>PLL_FAST</i>	Master clock
CKCE	MCK	4.9152 MHz	1.5728 MHz	–	CE clock
CKADC	MCK	4.9152 MHz, 2.4576 MHz	1.572864 MHz, 0.786432 MHz	<i>ADC_DIV</i>	ADC clock
CKMPU	MCK	4.9152 MHz ... 307.2 kHz	1.572864 MHz... 98.304 kHz	<i>MPU_DIV[2:0]</i>	MPU clock
CKICE	MCK	9.8304 MHz... 614.4 kHz	3.145728 MHz ... 196.608 kHz	<i>MPU_DIV[2:0]</i>	ICE clock
CKOPTMOD	MCK	38.40 kHz	38.6 kHz	–	Optical UART Modulation
CK32	MCK	32.768 kHz		–	32 kHz clock

2.5.4 Real-Time Clock (RTC)

2.5.4.1 RTC General Description

The RTC is driven directly by the crystal oscillator and is powered by either the V3P3SYS pin or the VBAT_RTC pin, depending on the V3OK internal bit. The RTC consists of a counter chain and output registers. The counter chain consists of registers for seconds, minutes, hours, day of week, day of month, month, and year. The chain registers are supported by a shadow register that facilitates read and write operations.

Table 40 shows the I/O RAM registers for accessing the RTC.

2.5.4.2 Accessing the RTC

Two bits, *RTC_RD* (I/O RAM 0x2890[6]) and *RTC_WR* (I/O RAM 0x2890[7]), control the behavior of the shadow register.

When *RTC_RD* is low, the shadow register is updated by the RTC after each two milliseconds. When *RTC_RD* is high, this update is halted and the shadow register contents become stationary and are suitable to be read by the MPU. Thus, when the MPU wishes to read the RTC, it freezes the shadow register by setting the *RTC_RD* bit, reads the shadow register, and then lowers the *RTC_RD* bit to let updates to the shadow register resume. Since the RTC clock is only 500 Hz, there may be a delay of approximately 2 ms from when the *RTC_RD* bit is lowered until the shadow register receives its first update. Reads to *RTC_RD* continues to return a one until the first shadow update occurs.

When *RTC_WR* is high, the update of the shadow register is also inhibited. During this time, the MPU may overwrite the contents of the shadow register. When *RTC_WR* is lowered, the shadow register is written into the RTC counter on the next 500Hz RTC clock. A 'change' bit is included for each word in the shadow register to ensure that only programmed words are updated when the MPU writes a zero to *RTC_WR*. Reads of *RTC_WR* returns one until the counter has actually been updated by the register.

The sub-second register of the RTC, *RTC_SBSC* (I/O RAM 0x2892), can be read by the MPU after the one second interrupt and before reaching the next one second boundary. *RTC_SBSC* contains the count since the last full second, in 1/128 second nominal clock periods, until the next one-second boundary. When the *RST_SUBSEC* bit is written, the *SUBSEC* counter is restarted, counting from 0 to 127. Reading and resetting the sub-second counter can be used as part of an algorithm to accurately set the RTC.

The RTC is capable of processing leap years. Each counter has its own output register. The RTC chain registers are not be affected by the reset pin, watchdog timer resets, or by transitions between the SLP mode and mission mode.

Table 40: RTC Control Registers

Name	Location	Rst	Wk	Dir	Description
<i>RTCA_ADJ</i> [6:0]	2504[6:0]	40	--	R/W	Register for analog RTC frequency adjustment.
<i>RTC_P</i> [16:14] <i>RTC_P</i> [13:6] <i>RTC_P</i> [5:0]	289B[2:0] 289C[7:0] 289D[7:2]	4 0 0	4 0 0	R/W	Registers for digital RTC adjustment. 0x0FFBF <i>RTC_P</i> 0x10040
<i>RTC_Q</i> [1:0]	289D[1:0]	0	0	R/W	Register for digital RTC adjustment.
<i>RTC_RD</i>	2890[6]	0	0	R/W	Freezes the RTC shadow register so it is suitable for MPU reads. When <i>RTC_RD</i> is read, it returns the status of the shadow register: 0 = up to date, 1 = frozen.
<i>RTC_WR</i>	2890[7]	0	0	R/W	Freezes the RTC shadow register so it is suitable for MPU write operations. When <i>RTC_WR</i> is cleared, the contents of the shadow register are written to the RTC counter on the next RTC clock (~1 kHz). When <i>RTC_WR</i> is read, it returns 1 as long as <i>RTC_WR</i> is set, and continues to return one until the RTC counter is updated.
<i>RTC_FAIL</i>	2890[4]	0	0	R	Indicates that a count error has occurred in the RTC and that the time is not trustworthy. This bit can be cleared by writing a 0.
<i>RTC_SBSC</i> [7:0]	2892[7:0]			R	Time remaining since the last 1 second boundary. LSB = 1/128 second.

2.5.4.3 RTC Rate Control

The 71M6545/H has two rate adjustment mechanisms:

The first rate adjustment mechanism is an analog rate adjustment, using the I/O RAM register *RTCA_ADJ*[6:0], that trims the crystal load capacitance.

The second rate adjustment mechanism is a digital rate adjust that affects the way the clock frequency is processed in the RTC.

Setting *RTCA_ADJ*[6:0] to 00 minimizes the load capacitance, maximizing the oscillator frequency. Setting *RTCA_ADJ*[6:0] to 0x7F maximizes the load capacitance, minimizing the oscillator frequency. The adjustable capacitance is approximately:

$$C_{ADJ} = \frac{RTCA_ADJ}{128} \cdot 16.5pF$$

The precise amount of adjustment depends on the crystal properties, the PCB layout and the value of the external crystal capacitors. The adjustment may occur at any time, and the resulting clock frequency should be measured over a one-second interval.

The second rate adjustment is digital, and can be used to adjust the clock rate up to 988ppm, with a resolution of 3.8 ppm (± 1.9 ppm). The rate adjustment is implemented starting at the next second-boundary following the adjustment. Since the LSB results in an adjustment every four seconds, the frequency should be measured over an interval that is a multiple of four seconds.

The clock rate is adjusted by writing the appropriate values to *RTC_P*[16:0] (I/O RAM 0x289B[2:0], 0x289C, 0x289D[7:2]) and *RTC_Q*[1:0] (I/O RAM 0x289D[1:0]). Updates to RTC rate adjust registers, *RTC_P* and *RTC_Q*, are done through the shadow register described above. The new values are loaded into the counters when *RTC_WR* (I/O RAM 0x2890[7]) is lowered.

The default frequency is 32,768 RTCLK cycles per second. To shift the clock frequency by ppm, *RTC_P* and *RTC_Q* are calculated using the following equation:

$$4 \text{ RTC_P } \text{ RTC_Q } \text{ floor } \frac{32768}{1} \frac{8}{10^6} 0.5$$

Conversely, the amount of ppm shift for a given value of $4\text{RTC_P} + \text{RTC_Q}$ is:

$$(\text{ppm}) \frac{32768}{4 \text{ RTC}_P \text{ RTC}_Q} 1 \cdot 10^6$$

For example, for a shift of -988 ppm, $4 \text{ RTC_P} + \text{RTC_Q} = 262403 = 0x40103$. $\text{RTC_P}[16:0] = 0x10040$, (I/O RAM $0x289B[2:0]$, $0x289C$, $0x289D[7:2]$) and $\text{RTC_Q}[1:0] = 0x03$ (I/O RAM $0x289D[1:0]$). The default values of $\text{RTC_P}[16:0]$ and $\text{RTC_Q}[1:0]$, corresponding to zero adjustment, are $0x10000$ and $0x0$, respectively.

Two settings for the TMUX2OUT test pin, PULSE_1S and PULSE_4S, are available for measuring and calibrating the RTC clock frequency. These are waveforms of approximately 25% duty cycle with 1s or 4s period.

- ✓ Default values for $\text{RTCA_ADJ}[6:0]$, $\text{RTC_P}[16:0]$ and $\text{RTC_Q}[1:0]$ should be nominal values, at the center of the adjustment range. Uncalibrated extreme values (zero, for example) can cause incorrect operation.

If the crystal temperature coefficient is known, the MPU can integrate temperature and correct the RTC time as necessary. Alternatively, the characteristics can be loaded into an NV RAM and the OSC_COMP (I/O RAM $0x28A0[5]$) bit may be set. In this case, the oscillator is adjusted automatically, even in SLP mode. See [2.5.4.4 RTC Temperature Compensation](#) for details.

2.5.4.4 RTC Temperature Compensation

The 71M6545/H can be configured to regularly measure die temperature, including in SLP mode, provided that the VBAT_RTC pin is supplied with a voltage within specification provided by a battery. If enabled by OSC_COMP , this temperature information is automatically used to correct for the temperature variation of the crystal. A table lookup method is used.

[Table 41](#) shows I/O RAM registers involved in automatic RTC temperature compensation.

Table 41: I/O RAM Registers for RTC Temperature Compensation

Name	Location	Rst	Wk	Dir	Description
OSC_COMP	28A0[5]	0	0	R/W	Enables the automatic update of $\text{RTC_P}[16:0]$ and $\text{RTC_Q}[1:0]$ every time the temperature is measured.
$\text{STEMP}[10:3]$ $\text{STEMP}[2:0]$	2881[7:0] 2882[7:5]	–	–	R	The result of the temperature measurement (10-bits of magnitude data plus a sign bit).
$\text{LKPADDR}[6:0]$	2887[6:0]	0	0	R/W	The address for reading and writing the RTC lookup RAM.
LKPAUTOI	2887[7]	0	0	R/W	Auto-increment flag. When set, $\text{LKPADDR}[6:0]$ auto increments every time LKP_RD or LKP_WR is pulsed. The incremented address can be read at $\text{LKPADDR}[6:0]$.
$\text{LKPDAT}[7:0]$	2888[7:0]	0	0	R/W	The data for reading and writing the RTC lookup RAM.
LKP_RD LKP_WR	2889[1] 2889[0]	0 0	0 0	R/W R/W	Strobe bits for the RTC lookup RAM read and write. When set, the $\text{LKPADDR}[6:0]$ and LKPDAT registers are used in a read or write operation. When a strobe is set, it stays set until the operation completes, at which time the strobe is cleared and $\text{LKPADDR}[6:0]$ is incremented if LKPAUTOI is set.

Referring to [Figure 13](#) the table lookup method uses the 10-bits plus sign-bit value in $\text{STEMP}[10:0]$ right-shifted by two bits to obtain an 8-bit plus sign value (i.e., NV RAM Address = $\text{STEMP}[10:0]/4$). A limiter ensures that the resulting look-up address is in the 6-bit plus sign range of -64 to +63 (decimal).

The 8-bit NV RAM content pointed to by the address is added as a 2's complement value to $0x40000$, the nominal value of $4 \cdot RTC_P[16:0] + RTC_Q[1:0]$.

Refer to [2.5.4.3 RTC Rate Control](#) for information on the rate adjustments performed by registers $RTC_P[16:0]$ and $RTC_Q[1:0]$. The 8-bit values loaded in to NV RAM must be scaled correctly to produce rate adjustments that are consistent with the equations given in [2.5.4.3 RTC Rate Control](#) for $RTC_P[16:0]$ and $RTC_Q[1:0]$. Note that the sum of the looked-up 8-bit 2's complement value and $0x40000$ form a 19-bit value, which is equal to $4 \cdot RTC_P[16:0] + RTC_Q[1:0]$, as shown in [Figure 13](#). The output of the Temperature Compensation is automatically loaded into the $RTC_P[16:0]$ and $RTC_Q[1:0]$ locations after each look-up and summation operation.

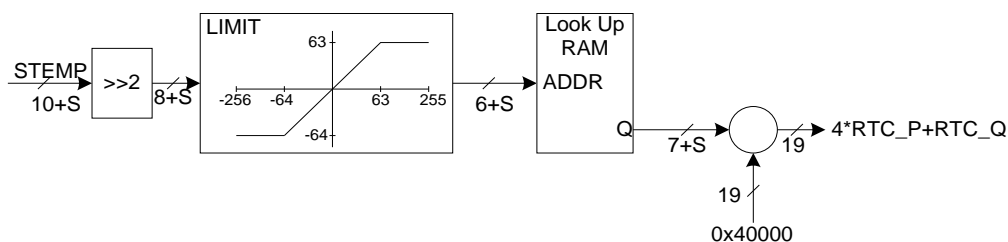

Figure 13: Automatic Temperature Compensation

As mentioned above, the $STEMP[10:0]$ digital temperature values are scaled such that the corresponding NV RAM addresses are equal to $STEMP[10:0]/4$ (limited in the range of -64 to +63). See [2.5.5 71M6545/H Temperature Sensor](#) on page 52 for the equations to calculate temperature in degrees °C from the $STEMP[10:0]$ reading.

For proper operation, the MPU has to load the lookup table with values that reflect the crystal properties with respect to temperature, which is typically done once during initialization. Since the lookup table is not directly addressable, the MPU uses the following procedure to load the NV RAM table:

1. Set the $LKPAUTOI$ bit (I/O RAM $0x2887[7]$) to enable address auto-increment.
2. Write zero into the I/O RAM register $LKPADDR[6:0]$ (I/O RAM $0x2887[6:0]$).
3. Write the 8-bit datum into I/O RAM register $LKPDAT$ (I/O RAM $0x2888$).
4. Set the LKP_WR bit (I/O RAM $0x2889[0]$) to write the 8-bit datum into NV_RAM
5. Wait for LKP_WR to clear (LKP_WR auto-clears when the data has been copied to NV RAM).
6. Repeat steps 3 through 5 until all data has been written to NV RAM.

The NV RAM table can also be read by writing a 1 into the LKP_RD bit (I/O RAM $0x2889[1]$). The process of reading from and writing to the NV RAM is accelerated by setting the $LKPAUTOI$ bit (I/O RAM $0x2887[7]$). When $LKPAUTOI$ is set, $LKPADDR[6:0]$ (I/O RAM $0x2887[6:0]$) auto-increments every time LKP_RD or LKP_WR is pulsed. It is also possible to perform random access of the NV RAM by writing a 0 to the $LKPAUTOI$ bit and loading the desired address into $LKPADDR[6:0]$.



If the oscillator temperature compensation feature is not being used, it is possible to use the NV RAM storage area as ordinary battery-backed NV storage space using the procedure described above to read and write NV RAM data. In this case, the OSC_COMP bit (I/O RAM $0x28A0[5]$) is reset to disable the automatic oscillator temperature compensation feature.

2.5.4.5 RTC Interrupts

The RTC generates interrupts each second and each minute. These interrupts are called RTC_1SEC and RTC_1MIN . In addition, the RTC functions as an alarm clock by generating an interrupt when the minutes and hours registers both equal their respective target counts. The alarm clock interrupt is called RTC_T . All three interrupts appear in the MPU's external interrupt 6. See [Table 31](#) in the interrupt section for the enable bits and flags for these interrupts.

The minute and hour target registers are listed in [Table 42](#).

Table 42: I/O RAM Registers for RTC Interrupts

Name	Location	Rst	Wk	Dir	Description
<i>RTC_TMIN[5:0]</i>	289E[5:0]	0	0	R/W	The target minutes register. See below.
<i>RTC_THR[4:0]</i>	289F[4:0]	0	0	R/W	The target hours register. The <i>RTC_T</i> interrupt occurs when <i>RTC_MIN[5:0]</i> becomes equal to <i>RTC_TMIN[5:0]</i> and <i>RTC_HR[4:0]</i> becomes equal to <i>RTC_THR[4:0]</i> .

2.5.5 71M6545/H Temperature Sensor

The 71M6545/H includes an on-chip temperature sensor for determining the temperature of its bandgap reference. The primary use of the temperature data is to determine the magnitude of compensation required to offset the thermal drift in the system for the compensation of current, voltage and energy measurement and the RTC. See [4.5 Metrology Temperature Compensation](#) on page 73. Also see [2.5.4.4 RTC Temperature Compensation](#) on page 50.

The temperature sensor can be used to compensate for the frequency variation of the crystal, during ac power outages, provided the VBAT_RTC voltage is within specification (supplied by a battery). See [2.5.4.4 RTC Temperature Compensation](#) on page 50.

In MSN mode, the temperature sensor is awakened on command from the MPU by setting the *TEMP_START* (I/O RAM 0x28B4[6]) control bit. During power outages and while operating from VBAT_RTC power, it is awakened at a regular rate set by *TEMP_PER[2:0]* (I/O RAM 0x28A0[2:0]).

The result of the temperature measurement can be read from the two I/O RAM locations *STEMP[10:3]* (I/O RAM 0x2881) and *STEMP[2:0]* (I/O RAM 0x2882[7:5]). Note that both of these I/O RAM locations must be read and properly combined to form the *STEMP[10:0]* 11-bit value (see *STEMP* in [Table 43](#)). The resulting 11-bit value is in 2's complement form and ranges from -1024 to +1023 (decimal). The equations below are used to calculate the sensed temperature from the 11-bit *STEMP[10:0]* reading.

For the 71M6545 in MSN Mode (with *TEMP_PWR* = 1):

$$Temp(^{\circ}C) = 0.325 \cdot STEMP_{10:0} + 64.4$$

For the temperature sensors in the 71M6545H:

If *STEMP* < 0:

$$Temp(^{\circ}C) = 0.325 \cdot STEMP_{10:0} + 0.00218 \cdot STEMP_{10:0}^2 - 0.609 \cdot STEMP_{10:0} + 64.4$$

If *STEMP* > 0:

$$Temp(^{\circ}C) = \frac{63 \cdot STEMP_{10:0}}{85} + 0.00218 \cdot STEMP_{10:0}^2 - 0.609 \cdot STEMP_{10:0} + 64.4$$

The *TEMP_85[10:0]* trim fuses are read from the Info Page. See [5.3 Reading the Info Page \(71M6545H only\)](#) on page 97 for information on how to read the 71M6545H trim fuses.

[Table 43](#) shows the I/O RAM registers used for temperature and battery measurement.

- ✓ If *TEMP_PWR* selects VBAT_RTC when the battery is nearly discharged, the temperature measurement may not finish. In this case, firmware may complete the measurement by selecting V3P3D (*TEMP_PWR* = 1).

Table 43: I/O RAM Registers for Temperature and Battery Measurement

Name	Location	Rst	Wk	Dir	Description								
<i>TBYTE_BUSY</i>	28A0[3]	0	0	R	Indicates that hardware is still writing the 0x28A0 byte. Additional writes to this byte are locked out while it is one. Write duration could be as long as 6 ms.								
<i>TEMP_PER[2:0]</i>	28A0[2:0]	0	–	R/W	<p>Sets the period between temperature measurements. Automatic measurements can be enabled in any mode (MSN and during ac power outages if the VBAT_RTC voltage is within specification, as supplied by a battery).</p> <table border="1"> <thead> <tr> <th><i>TEMP_PER</i></th> <th>Time</th> </tr> </thead> <tbody> <tr> <td>0</td> <td>Manual updates (see <i>TEMP_START</i>)</td> </tr> <tr> <td>1-6</td> <td>$2^{\wedge}(3+TEMP_PER)$ (seconds)</td> </tr> <tr> <td>7</td> <td>Continuous</td> </tr> </tbody> </table>	<i>TEMP_PER</i>	Time	0	Manual updates (see <i>TEMP_START</i>)	1-6	$2^{\wedge}(3+TEMP_PER)$ (seconds)	7	Continuous
<i>TEMP_PER</i>	Time												
0	Manual updates (see <i>TEMP_START</i>)												
1-6	$2^{\wedge}(3+TEMP_PER)$ (seconds)												
7	Continuous												
<i>TEMP_BAT</i>	28A0[4]	0	–	R/W	Causes the VBAT_RTC pin to be measured whenever a temperature measurement is performed.								
<i>TEMP_START</i>	28B4[6]	0	–	R/W	<i>TEMP_PER[2:0]</i> must be zero in order for <i>TEMP_START</i> to function. If <i>TEMP_PER[2:0]</i> = 0, then setting <i>TEMP_START</i> starts a temperature measurement. This bit is ignored in SLP mode. Hardware clears <i>TEMP_START</i> when the temperature measurement is complete.								
<i>TEMP_PWR</i>	28A0[6]	0	–	R/W	Selects the power source for the temperature sensor: 1 = V3P3D, 0 = VBAT_RTC. This bit is ignored in SLP mode, where the temperature sensor is always powered by VBAT_RTC.								
Reserved	28A0[7]	0	–	R/W	Must always be zero.								
<i>TEMP_TEST[1:0]</i>	2500[1:0]	0	–	R/W	<p>Test bits for the temperature monitor VCO. <i>TEMP_TEST</i> must be 00 in regular operation. Any other value causes the VCO to run continuously with the control voltage described below.</p> <table border="1"> <thead> <tr> <th><i>TEMP_TEST</i></th> <th>Function</th> </tr> </thead> <tbody> <tr> <td>00</td> <td>Normal operation</td> </tr> <tr> <td>01</td> <td>Reserved for factory test</td> </tr> <tr> <td>1X</td> <td>Reserved for factory test</td> </tr> </tbody> </table>	<i>TEMP_TEST</i>	Function	00	Normal operation	01	Reserved for factory test	1X	Reserved for factory test
<i>TEMP_TEST</i>	Function												
00	Normal operation												
01	Reserved for factory test												
1X	Reserved for factory test												
<i>STEMP[10:3]</i> <i>STEMP[2:0]</i>	2881[7:0] 2882[7:5]			R R	<p>The result of the temperature measurement. The <i>STEMP[10:0]</i> value may be obtained in C with a single 16-bit read and divide by 32 operation as follows:</p> <pre>volatile int16_t xdata STEMPT_at_0x2881; fa = (float)(STEMPT/32);</pre>								
<i>BSENSE[7:0]</i>	2885[7:0]	–	–	R	The result of the battery measurement.								
<i>BCURR</i>	2704[3]	0	0	R/W	Connects a 100 μ A load to the battery (VBAT_RTC pin).								

2.5.6 71M6xx3 Temperature Sensor

The 71M6xx3 includes an on-chip temperature sensor for determining the temperature of its bandgap reference. The primary use of the temperature data is to determine the magnitude of compensation required to offset the thermal drift in the system for the compensation of the current measurement performed by the 71M6xx3. See the 71M6xxx Data Sheet for the equation to calculate temperature from the 71M6xx3 *STEMP[10:0]* reading. Also, see [4.5 Metrology Temperature Compensation](#) on page 73.

See [2.2.8.3 Control of the 71M6xx3 Isolated Sensor](#) on page 21 for information on how to read the *STEMP[10:0]* information from the 71M6xx3.

2.5.7 71M6545/H Battery Monitor

The 71M6545/H temperature measurement circuit can also monitor the battery at the VBAT_RTC pin.

When *TEMP_BAT* (*I/O RAM 0x28A0[4]*) is set, a battery measurement is performed as part of each temperature measurement. The value of the battery reading is stored in register *BSENSE[7:0]* (*I/O RAM 0x2885*). The following equations are used to calculate the voltage measured on the VBAT_RTC pin from the *BSENSE[7:0]* and *STEMP[10:0]* values. The result of the equation below is in volts. In MSN mode, *TEMP_PWR* = 1 use:

$$VBAT_RTC = 3.3V - (BSENSE[7:0] \cdot 0.0246V) + (STEMP[10:0] \cdot 0.000297V)$$

In MSN mode, a 100 μ A de-passivation load can be applied to the battery by setting the *BCURR* (*I/O RAM 0x2704[3]*) bit. Battery impedance can be measured by taking a battery measurement with and without *BCURR*. Regardless of the *BCURR* bit setting, the battery load is never applied in SLP mode.

2.5.8 71M6xx3 VCC Monitor

The 71M6xx3 monitors its VCC pin voltage. The voltage of the VCC pin can be obtained by the 71M6545/H by issuing a read command to the 71M6xx3. The 71M6545/H must request both the *VSENSE[7:0]* and *STEMP[10:0]* values from the 71M6xx3. See the 71M6xxx Data Sheet for the equation to calculate the 71M6xx3 VCC pin voltage from the *VSENSE[7:0]* and *STEMP[10:0]* values read from the 71M6xx3.

See [2.2.8.3 Control of the 71M6xx3 Isolated Sensor](#) on page 21 for information on how to read *VSENSE[7:0]* and *STEMP[10:0]* from the 71M6xx3 remote sensors.

2.5.9 UART Interface

The 71M6545/H provides an asynchronous interface (UART). The UART can be used to connect to AMR modules, user interfaces, etc., and also support a mechanism for programming the on-chip flash memory.

2.5.10 DIO Pins

On reset or power-up, all DIO pins are DIO inputs until they are configured for the desired configuration under MPU control.



After reset or power up, pins DIO0 through DIO14 are initially DIO outputs, but are disabled by *PORT_E* = 0 (*I/O RAM 0x270C[5]*) to avoid unwanted pulses. After configuring pins DIO0 through DIO14 the host enables the pins by setting *PORT_E* = 1.

DIO pins can be configured independently as an input or output. For DIO0 to DIO14, this is done with the SFR registers *P0* (*SFR 0x80*), *P1* (*SFR 0x90*), *P2* (*SFR 0xA0*) and *P3* (*SFR 0xB0*) as shown in [Table 44](#).

Example: DIO12 (pin 19, gray fields in [Table 44](#)) is configured as a DIO output pin with a value of 1 (high) by writing 1 to both *P3[4]* and *P3[0]*.

Table 44: Data/Direction Registers and Internal Resources for DIO0 to DIO14

DIO	0	1	2	3	4	5	6	7	8	9	10	11	12	13	14	
Pin #	31	30	29	28	27	26	25	24	23	22	21	20	19	18	17	
DIO Data Register	0	1	2	3	0	1	2	3	0	1	2	3	0	1	2	
	<i>P0</i> (SFR80)				<i>P1</i> (SFR90)				<i>P2</i> (SFRA0)				<i>P3</i> (SFRB0)			
Direction Register: 0 = input, 1 = output	4	5	6	7	4	5	6	7	4	5	6	7	4	5	6	
	<i>P0</i> (SFR80)				<i>P1</i> (SFR90)				<i>P2</i> (SFRA0)				<i>P3</i> (SFRB0)			
Internal Resources Configurable	--	--	--	--	Y	Y	Y	Y	Y	Y	Y	Y	-	-	-	

The configuration for pins DIO19 to DIO25, DIO28 and DIO29 are shown in [Table 45](#)
The configuration for pins DIO55 is shown in [Table 46](#).

Table 45: Data/Direction Registers for DIO19-25 and DIO28-29

DIO				19	20	21	22	23	24	25			28	29		
Pin #				14	13	12	11	10	9	8			7	6		
DIO Data Register				19	20	21	22	23	24	25			28	29		
	<i>DIO16[0] to DIO31[0]</i> (I/O RAM 0x2420[0] to 0x242F[0])															
Direction Register: 0 = input, 1 = output				19	20	21	22	23	24	25			28	29		
	<i>DIO16[1] to DIO31[1]</i> (I/O RAM 0x2420[1] to 0x242F[1])															

Table 46: Data/Direction Registers for DIO55

DIO	-	-	-	-	55	-	-	-
Pin #	-	-	-	-	32	-	-	-
DIO Data Register	-	-	-	-	55	-	-	-
	<i>DIO51[0] to DIO55[0]</i> (I/O RAM 0x2443[0] to 0x2447[0])							
Direction Register: 0 = input, 1 = output	-	-	-	-	55	-	-	-
	<i>DIO51[1] to DIO55[1]</i> (I/O RAM 0x2443[1] to 0x2447[1])							

The PB pin is a dedicated digital input and is not part of the DIO system.



The CE features pulse counting registers and the CE pulse outputs are directly routed to the pulse interrupt input. Thus, no routing of pulse signals to external pins is required in order to generate pulse interrupts.

A 3-bit configuration word, I/O RAM register *DIO_Rn[2:0]* (I/O RAM 0x2009[2:0] through 0x200E[6:4]) can be used for pins DIO2 through DIO11 (when configured as DIO) and PB to individually assign an internal resource such as an interrupt or a timer control (*DIO_RPB[2:0]*, I/O RAM 0x2450[2:0], configures the PB pin). This way, DIO pins can be tracked even if they are configured as outputs. [Table 47](#) lists the internal resources which can be assigned using *DIO_R2[2:0]* (also called *DIO_RPB[2:0]*) through *DIO_R11[2:0]* and *DIO_RPB[2:0]*. If more than one input is connected to the same resource, the resources are combined using a logical OR.

Table 47: Selectable Resources using the *DIO_Rn[2:0]* Bits

Value in <i>DIO_Rn[2:0]</i>	Resource Selected for DIO _n or PB Pin
0	None
1	Reserved
2	T0 (counter0 clock)
3	T1 (counter1 clock)
4	High priority I/O interrupt (INT0)
5	Low priority I/O interrupt (INT1)



When driving LEDs, relay coils etc., the DIO pins should sink the current into GNDD (as shown in [Figure 14](#), right), not source it from V3P3D (as shown in [Figure 14](#), left). This is due to the resistance of the internal switch that connects V3P3D to V3P3SYS.



Sourcing current in or out of DIO pins other than those dedicated for wake functions, for example with pull-up or pull-down resistors, should be avoided. Violating this rule leads to increased quiescent current from a battery connected to the VBAT_RTC pin during SLP mode.

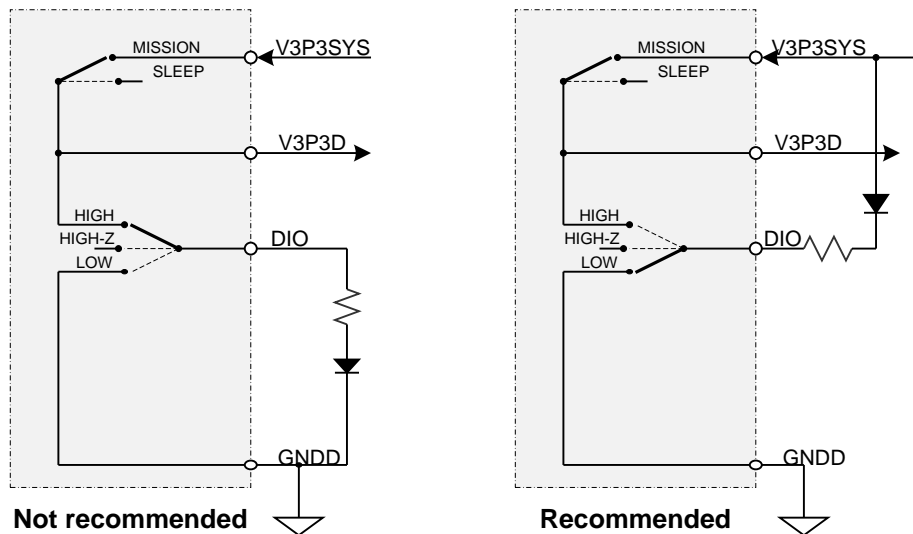

Figure 14: Connecting an External Load to DIO Pins

2.5.11 EEPROM Interface

The 71M6545/H provides hardware support for either a two-pin or a three-wire (μ -wire) type of EEPROM interface. The interfaces use the *EECTRL* (SFR 0x9F) and *EEDATA* (SFR 0x9E) registers for communication.

Two-pin EEPROM Interface

The dedicated 2-pin serial interface communicates with external EEPROM devices. The interface is multiplexed onto the DIO2 (SDCK) and DIO3 (SDATA) pins and is selected by setting *DIO_EEX*[1:0] = 01 (*I/O RAM* 0x2456[7:6]). The MPU communicates with the interface through the SFR registers *EEDATA* and *EECTRL*. If the MPU wishes to write a byte of data to the EEPROM, it places the data in *EEDATA* and then writes the Transmit code to *EECTRL*. This initiates the transmit operation which is finished when the *BUSY* bit falls. *INT5* is also asserted when *BUSY* falls. The MPU can then check the *RX_ACK* bit to see if the EEPROM acknowledged the transmission.

A byte is read by writing the Receive command to *EECTRL* and waiting for the *BUSY* bit to fall. Upon completion, the received data is in *EEDATA*. The serial transmit and receive clock is 78 kHz during each transmission, and then holds in a high state until the next transmission. The *EECTRL* bits when the two-pin interface is selected are shown in Table 48.

Table 48: *EECTRL* Bits for 2-pin Interface

Status Bit	Name	Read/Write	Reset State	Polarity	Description	
7	<i>ERROR</i>	R	0	Positive	1 when an illegal command is received.	
6	<i>BUSY</i>	R	0	Positive	1 when serial data bus is busy.	
5	<i>RX_ACK</i>	R	1	Positive	1 indicates that the EEPROM sent an ACK bit.	
4	<i>TX_ACK</i>	R	1	Positive	1 indicates when an ACK bit has been sent to the EEPROM.	
3:0	<i>CMD</i> [3:0]	W	0000	Positive	<i>CMD</i> [3:0]	
					0000	No-op command. Stops the I ² C clock (SDCK). If not issued, SDCK keeps toggling.
					0010	Receive a byte from the EEPROM and send ACK.
					0011	Transmit a byte to the EEPROM.
					0101	Issue a STOP sequence.

Status Bit	Name	Read/Write	Reset State	Polarity	Description
					0110 Receive the last byte from the EEPROM and do not send ACK.
					1001 Issue a START sequence.
					Others No operation, set the <i>ERROR</i> bit.

- ✓ The EEPROM interface can also be operated by controlling the DIO2 and DIO3 pins directly. The direction of the DIO line can be changed from input to output and an output value can be written with a single write operation, thus avoiding collisions (see [Table 14 Port Registers \(DIO0-14\)](#)). Therefore, no resistor is required in series SDATA to protect against collisions.

Three-Wire (μ-Wire) EEPROM Interface with Single Data Pin

A 500 kHz three-wire interface, using SDATA, SDCK, and a DIO pin for CS is available. The interface is selected by setting $DIO_EEX[1:0] = 10$. The *EECTRL* bits when the three-wire interface is selected are shown in [Table 49](#). When *EECTRL* is written, up to 8 bits from *EEDATA* are either written to the EEPROM or read from the EEPROM, depending on the values of the *EECTRL* bits.

Three-Wire (μ-Wire/SPI) EEPROM Interface with Separate Di/DO Pins

If $DIO_EEX[1:0] = 11$, the 71M6545/H three-wire interface is the same as above, except DI and DO are separate pins. In this case, DIO3 becomes DO and DIO8 becomes DI. The timing diagrams are the same as for $DIO_EEX[1:0] = 10$ except that all output data appears on DO and all input data is expected on DI. In this mode, DI is ignored while data is being received on DO. This mode is compatible with SPI modes 0,0 and 1,1 where data is shifted out on the falling edge of the clock and is strobed in on the rising edge of the clock.

Table 49: *EECTRL* Bits for the 3-wire Interface

Control Bit	Name	Read/Write	Description
7	<i>WFR</i>	W	Wait for Ready. If this bit is set, the trailing edge of BUSY is delayed until a rising edge is seen on the data line. This bit can be used during the last byte of a Write command to cause the INT5 interrupt to occur when the EEPROM has finished its internal write sequence. This bit is ignored if HiZ=0.
6	<i>BUSY</i>	R	Asserted while the serial data bus is busy. When the BUSY bit falls, an INT5 interrupt occurs.
5	<i>HiZ</i>	W	Indicates that the SD signal is to be floated to high impedance immediately after the last SDCK rising edge.
4	<i>RD</i>	W	Indicates that <i>EEDATA</i> (<i>SFR 0x9E</i>) is to be filled with data from EEPROM.
3:0	<i>CNT[3:0]</i>	W	Specifies the number of clocks to be issued. Allowed values are 0 through 8. If $RD = 1$, CNT bits of data are read MSB first, and right justified into the low order bits of <i>EEDATA</i> . If $RD = 0$, CNT bits are sent MSB first to the EEPROM, shifted out of the MSB of <i>EEDATA</i> . If <i>CNT[3:0]</i> is zero, SDATA simply obeys the HiZ bit.

The timing diagrams in [Figure 15](#) through [Figure 19](#) describe the 3-wire EEPROM interface behavior. All commands begin when the *EECTRL* register is written. Transactions start by first raising the DIO pin that is connected to CS. Multiple 8-bit or less commands such as those shown in [Figure 15](#) through [Figure 19](#) are then sent via *EECTRL* and *EEDATA*.

When the transaction is finished, CS must be lowered. At the end of a Read transaction, the EEPROM drives SDATA, but transitions to HiZ (high impedance) when CS falls. The firmware should then immediately issue a write command with CNT=0 and HiZ=0 to take control of SDATA and force it to a low-Z state.

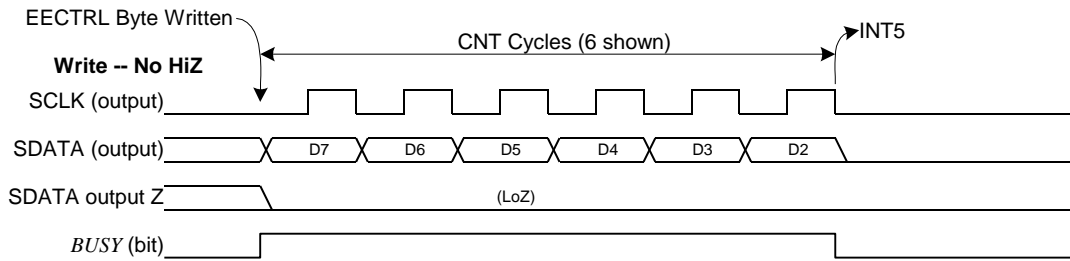

Figure 15: 3-wire Interface. Write Command, HiZ=0.

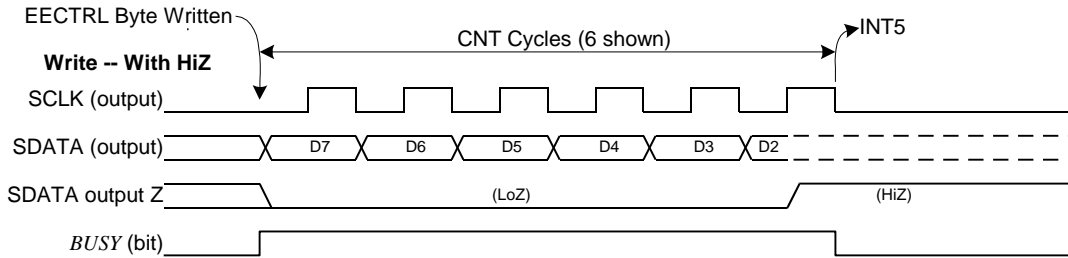

Figure 16: 3-wire Interface. Write Command, HiZ=1

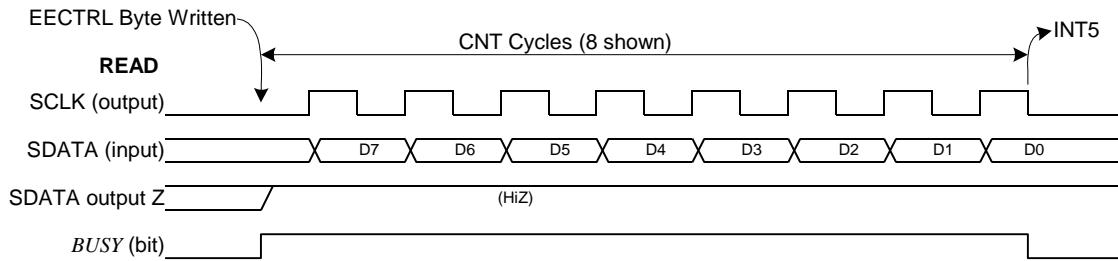

Figure 17: 3-wire Interface. Read Command.

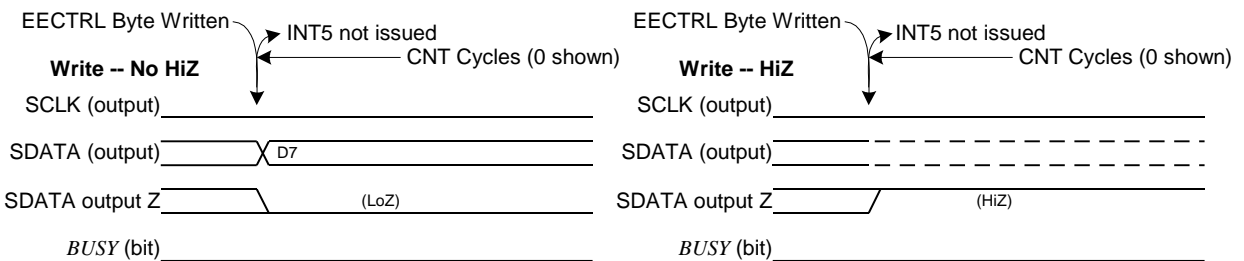

Figure 18: 3-Wire Interface. Write Command when CNT=0

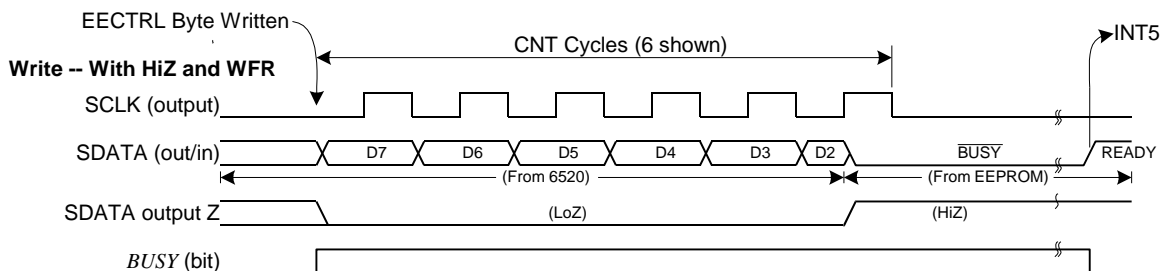

Figure 19: 3-wire Interface. Write Command when HiZ=1 and WFR=1.

2.5.12 SPI Slave Port

The slave SPI port communicates directly with the MPU data bus and is able to read and write Data RAM and Configuration RAM (I/O RAM) locations. It is also able to send commands to the MPU. The interface to the slave port consists of the SPI_CSZ, SPI_CKI, SPI_DI and SPI_DO pins.

Additionally, the SPI interface allows flash memory to be read and to be programmed. To facilitate flash programming, cycling power or asserting RESET causes the SPI port pins to default to SPI mode. The SPI port is disabled by clearing the *SPI_E* bit (I/O RAM 0x270C[4]).

Possible applications for the SPI interface are:

- 1) An external host reads data from CE locations to obtain metering information. This can be used in applications where the 71M6545/H function as a smart front-end with preprocessing capability. Since the addresses are in 16-bit format, any type of XRAM data can be accessed: CE, MPU, I/O RAM, but not SFRs or the 80515-internal register bank.
- 2) A communication link can be established via the SPI interface: By writing into MPU memory locations, the external host can initiate and control processes in the 71M6545/H MPU. Writing to a CE or MPU location normally generates an interrupt, a function that can be used to signal to the MPU that the byte that had just been written by the external host must be read and processed. Data can also be inserted by the external host without generating an interrupt.
- 3) An external DSP can access front-end data generated by the ADC. This mode of operation uses the 71M6545/H as an analog front-end (AFE).
- 4) Flash programming by the external host (SPI Flash Mode).

SPI Transactions

A typical SPI transaction is as follows. While SPI_CSZ is high, the port is held in an initialized/reset state. During this state, SPI_DO is held in high impedance state and all transitions on SPI_CLK and SPI_DI are ignored. When SPI_CSZ falls, the port begins the transaction on the first rising edge of SPI_CLK. As shown in [Table 50](#), a transaction consists of an optional 16 bit address, an 8 bit command, an 8 bit status byte, followed by one or more bytes of data. The transaction ends when SPI_CSZ is raised. Some transactions may consist of a command only.

When SPI_CSZ rises, SPI command bytes that are not of the form x0000000 cause the *SPI_CMD* (SFR 0xFD) register to be updated and then cause an interrupt to be issued to the MPU. The exception is if the transaction was a single byte. In this case, the *SPI_CMD* byte is always updated and the interrupt issued. *SPI_CMD* is not cleared when SPI_CSZ is high.

The SPI port supports data transfers up to 10 Mb/s. A serial read or write operation requires at least 8 clocks per byte, guaranteeing SPI access to the RAM is no faster than 1.25 MHz, thus ensuring that SPI access to DRAM is always possible.

Table 50: SPI Transaction Fields

Field Name	Required	Size (bytes)	Description
Address	Yes, except single byte transaction	2	16-bit address. The address field is not required if the transaction is a simple SPI command.
Command	Yes	1	8-bit command. This byte can be used as a command to the MPU. In multi-byte transactions, the MSB is the R/W bit. Unless the transaction is multi-byte and <i>SPI_CMD</i> is exactly 0x80 or 0x00, the <i>SPI_CMD</i> register is updated and an SPI interrupt is issued. Otherwise, the <i>SPI_CMD</i> register is unchanged and the interrupt is not issued.
Status	Yes, if transaction includes DATA	1	8-bit status field, indicating the status of the previous transaction. This byte is also available in the MPU memory map as <i>SPI_STAT</i> (I/O RAM 0x2708). See Table 52 for the contents.
Data	Yes, if transaction includes DATA	1 or more	The read or write data. Address is auto incremented for each new byte.

The *SPI_STAT* byte is output on every SPI transaction and indicates the parity of the previous transaction and the error status of the previous transaction. Potential error sources are:

71M6545/H not ready

Transaction not ending on a byte boundary.

SPI Safe Mode

Sometimes it is desirable to prevent the SPI interface from writing to arbitrary RAM locations and thus disturbing MPU and CE operation. This is especially true in AFE applications. For this reason, the SPI SAFE mode was created. In SPI SAFE mode, SPI write operations are disabled except for a 16 byte transfer region at address 0x400 to 0x40F. If the SPI host needs to write to other addresses, it must use the *SPI_CMD* register to request the write operation from the MPU. SPI SAFE mode is enabled by the *SPI_SAFE* bit (I/O RAM 0x270C[3]).

Single-Byte Transaction

If a transaction is a single byte, the byte is interpreted as *SPI_CMD*. Regardless of the byte value, single-byte transactions always update the *SPI_CMD* register and cause an SPI interrupt to be generated.

Multi-Byte Transaction

As shown in Figure 20, multi-byte operations consist of a 16 bit address field, an 8 bit CMD, a status byte, and a sequence of data bytes. A multi byte transaction is three or more bytes.

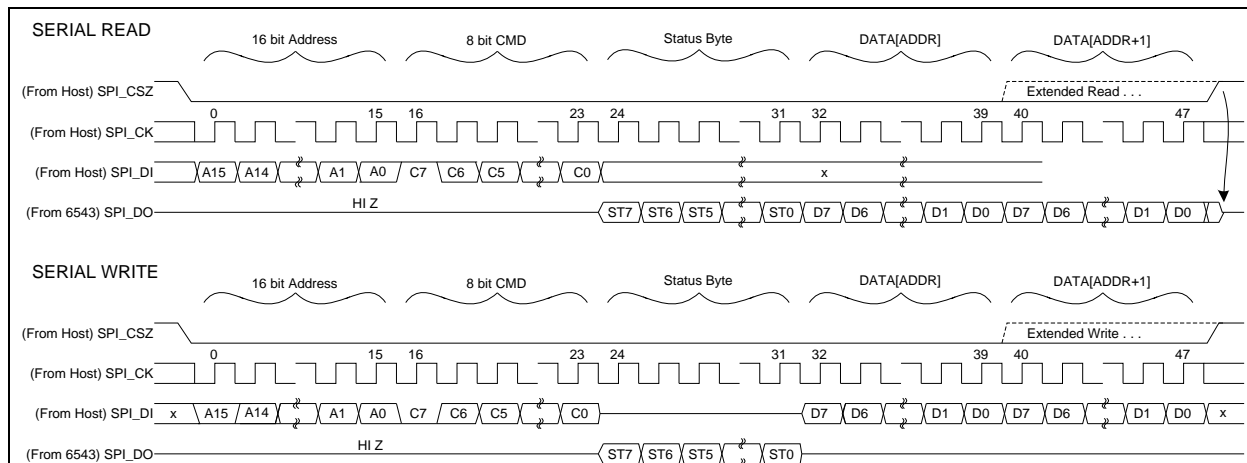

Figure 20: SPI Slave Port - Typical Multi-Byte Read and Write operations

Table 51: SPI Command Sequences

Command Sequence	Description
ADDR 1xxx xxxx STATUS Byte0 ... ByteN	Read data starting at ADDR. ADDR is auto-incremented until SPI_CSZ is raised. Upon completion, <i>SPI_CMD</i> (SFR 0xFD) is updated to 1xxx xxxx and an SPI interrupt is generated. The exception is if the command byte is 1000 0000. In this case, no MPU interrupt is generated and <i>SPI_CMD</i> is not updated.
ADDR 0xxx xxxx STATUS Byte0 ... ByteN	Write data starting at ADDR. ADDR is auto-incremented until SPI_CSZ is raised. Upon completion, <i>SPI_CMD</i> is updated to 0xxx xxxx and an SPI interrupt is generated. The exception is if the command byte is 0000 0000. In this case, no MPU interrupt is generated and <i>SPI_CMD</i> is not updated.

Table 52: SPI Registers

Name	Location	Rst	Wk	Dir	Description
<i>EX_SPI</i>	2701[7]	0	0	R/W	SPI interrupt enable bit.
<i>SPI_CMD</i>	SFR FD[7:0]	–	–	R	SPI command. The 8-bit command from the bus master.
<i>SPI_E</i>	270C[4]	1	1	R/W	SPI port enable bit. It enables the SPI interface on pins SPI_DI, SPI_DO, SPI_CSZ and SPI_CK1.
<i>IE_SPI</i>	SFR F8[7]	0	0	R/W	SPI interrupt flag. Set by hardware, cleared by writing a 0.
<i>SPI_SAFE</i>	270C[3]	0	0	R/W	Limits SPI writes to <i>SPI_CMD</i> and a 16 byte region in DRAM when set. No other write operations are permitted.
<i>SPI_STAT</i>	2708[7:0]	0	0	R	<p><i>SPI_STAT</i> contains the status results from the previous SPI transaction</p> <p>Bit 7 - 71M6545/H ready error: the 71M6545/H was not ready to read or write as directed by the previous command.</p> <p>Bit 6 - Read data parity: This bit is the parity of all bytes read from the 71M6545/H in the previous command. Does not include the SPI_STAT byte.</p> <p>Bit 5 - Write data parity: This bit is the overall parity of the bytes written to the 71M6545/H in the previous command. It includes CMD and ADDR bytes.</p> <p>Bit 4:2 - Bottom 3 bits of the byte count. Does not include ADDR and CMD bytes. One, two, and three byte instructions return 111.</p> <p>Bit 1 - SPI FLASH mode: This bit is zero when the TEST pin is zero.</p> <p>Bit 0 - SPI FLASH mode ready: Used in SPI FLASH mode. Indicates that the flash is ready to receive another write instruction.</p>

SPI Flash Mode (SFM)

In normal operation, the SPI slave interface cannot read or write the flash memory. However, the 71M6545/H supports a special flash mode (SFM) which facilitates initial programming of the flash memory. When the 71M6545/H is in this mode, the SPI can erase, read, and write the flash memory. Other memory elements such as XRAM and IO RAM are not accessible in this mode. In order to protect the flash contents, several operations are required before the SFM mode is successfully invoked.

In SFM mode, the 71M6545/H supports n byte reads and dual-byte writes to flash memory. See the [SPI Transaction](#) description on Page 59 for the format of read and write commands. Since the flash write

operation is always based on a two-byte word, the initial address must always be even. Data is written to the 16-bit flash memory bus after the odd word is written.

In SFM mode, the MPU is completely halted. For this reason, the interrupt feature described in the SPI Transaction section above is not available in SFM mode. The 71M6545/H must be reset by the WD timer or by the RESET pin in order to exit SFM mode.

Invoking SFM

The following conditions must be met prior to invoking SFM:

ICE_E = 1. This disables the watchdog and adds another layer of protection against inadvertent Flash corruption.

The external power source (V3P3SYS, V3P3A) is at the proper level (> 3.0 VDC).

PREBOOT = 0 (SFR 0xB2[7]). This validates the state of the SECURE bit (SFR 0xB2[6]).

SECURE = 0. This I/O RAM register indicates that SPI secure mode is not enabled. Operations are limited to SFM Mass Erase mode if the SECURE bit = 1 (Flash read back is not allowed in Secure mode).

FLSH_UNLOCK[3:0] = 0010 (I/O RAM 0x2702[7:4]).

The I/O RAM registers *SFMM* (I/O RAM 0x2080) and *SFMS* (I/O RAM 0x2081) are used to invoke SFM. Only the SPI interface has access to these two registers. This eliminates an indirect path from the MPU for disabling the watchdog. *SFMM* and *SFMS* need to be written to in sequence in order to invoke SFM. This sequential write process prevents inadvertent entering of SFM. The sequence for invoking SFM is:

First, write to *SFMM* (I/O RAM 0x2080) register. The value written to this register defines the SFM mode.

- 0xD1: Mass Erase mode. A Flash Mass erase cycle is invoked upon entering SFM.
- 0x2E: Flash Read back mode. SFM is entered for Flash read back purposes. Flash writes are blocked and it is up to the user to guarantee that only previously unwritten locations are written. This mode is not accessible when SPI secure mode is set.
- SFM is not invoked if any other pattern is written to the *SFMM* register.

Next, write 0x96 to the *SFMS* (I/O RAM 0x2081) register. This write invokes SFM provided that the previous write operation to *SFMM* met the requirements. Writing any other pattern to this register does not invoke SFM. Additionally, any write operations to this register automatically reset the previously written *SFMM* register values to zero.

SFM Details

The following occurs upon entering SFM.

The CE is disabled.

The MPU is halted. Once the MPU is halted it can only be restarted with a reset. This reset can be accomplished with the RESET pin, a watchdog reset, or by cycling power.

The Flash control logic is reset in case the MPU was in the middle of a Flash write operation or Erase cycle.

Mass erase is invoked if specified in the *SFMM* (I/O RAM 0x2080) register (see Invoking SFM, above). The SECURE bit (SFR 0xB2[6]) is cleared at the end of this and all Mass Erase cycles.

All SPI read and write operations now refer to Flash instead of XRAM space.

The SPI host can access the current state of the pending multi-cycle Flash access by performing a 4-byte SPI write of any address and checking the status field.

All SPI write operations in SFM mode must be 6-byte write transactions that write two bytes to an even address. The write transactions must contain a command byte of 0x00 which is the form that does not create an MPU interrupt. Auto incrementing is disabled for write operations.

SPI read transactions can make use of auto increment and may access single bytes. The command byte must always be 0x80 in SFM read transactions.

SPI Commands in SFM

Interrupts are not generated in SFM since the MPU is halted. The format of the commands is shown in the [SPI Transactions](#) description.

2.5.13 Hardware Watchdog Timer

An independent, robust, fixed-duration, watchdog timer (WDT) is included in the 71M6545/H. It uses the RTC crystal oscillator as its time base and must be refreshed by the MPU firmware at least every 1.5 seconds. When not refreshed on time, the WDT overflows and the part is reset as if the RESET pin were pulled high, except that the I/O RAM bits are in the same state as after a wake-up from SLP mode (see the I/O RAM description in [5.2](#) for a list of I/O RAM bit states after RESET and wake-up). Four thousand, one hundred CK32 cycles (or 125 ms) after the WDT overflow, the MPU is launched from program address 0x0000.

The watchdog timer is also reset when the internal signal WAKE=0. The WDT is disabled when the ICE_E pin is pulled high.

2.5.14 Test Ports (TMUXOUT and TMUX2OUT Pins)

Two independent multiplexers allow the selection of internal analog and digital signals for the TMUXOUT and TMUX2OUT pins.

One of the digital or analog signals listed in [Table 53](#) can be selected to be output on the TMUXOUT pin. The function of the multiplexer is controlled with the I/O RAM register *TMUX[4:0]* (I/O RAM 0x2502[4:0]), as shown in [Table 53](#).

One of the digital or analog signals listed in [Table 54](#) can be selected to be output on the TMUX2OUT pin. The function of the multiplexer is controlled with the I/O RAM register *TMUX2[4:0]* (I/O RAM 0x2503[4:0]), as shown in [Table 54](#).

- ✓ The TMUX and TMUX2 I/O RAM locations are non-volatile and their contents are preserved by battery power and across resets.

The TMUXOUT and TMUX2OUT pins may be used for diagnosis purposes or in production test. The RTC 1-second output may be used to calibrate the crystal oscillator. The RTC 4-second output provides even higher precision.

Table 53: *TMUX[4:0]* Selections

<i>TMUX[5:0]</i>	Signal Name	Description
1	RTCLK	32.768 kHz clock waveform
9	WD_RST	Indicates when the MPU has reset the watchdog timer. Can be monitored to determine spare time in the watchdog timer.
A	CKMPU	MPU clock – see Table 8
D	V3AOK bit	Indicates that the V3P3A pin voltage is 3.0 V. The V3P3A and V3P3SYS pins are expected to be tied together at the PCB level. The 71M6545/H monitors the V3P3A pin voltage only.
E	V3OK bit	Indicates that the V3P3A pin voltage is 2.8 V. The V3P3A and V3P3SYS pins are expected to be tied together at the PCB level. The 71M654 monitors the V3P3A pin voltage only.
1B	MUX_SYNC	Internal multiplexer frame SYNC signal. See Figure 4 and Figure 5 .
1C	CE_BUSY interrupt	See 2.3.3 on page 24 and Figure 12 on page 44
1D	CE_XFER interrupt	
1F	RTM output from CE	See 2.3.5 on page 25
Note: All <i>TMUX[5:0]</i> values which are not shown are reserved.		

Table 54: TMUX2[4:0] Selections

<i>TMUX2[4:0]</i>	Signal Name	Description
0	WD_OVF	Indicates when the watchdog timer has expired (overflowed).
1	PULSE_1S	One second pulse with 25% Duty Cycle. This signal can be used to measure the deviation of the RTC from an ideal 1 second interval. Multiple cycles should be averaged together to filter out jitter.
2	PULSE_4S	Four second pulse with 25% Duty Cycle. This signal can be used to measure the deviation of the RTC from an ideal 4 second interval. Multiple cycles should be averaged together to filter out jitter. The 4 second pulse provides a more precise measurement than the 1 second pulse.
3	RTCLK	32.768 kHz clock waveform
8	SPARE[1] bit – I/O RAM <i>0x2704[1]</i>	Copies the value of the bit stored in 0x2704[1]. For general purpose use.
9	SPARE[2] bit – I/O RAM <i>0x2704[2]</i>	Copies the value of the bit stored in 0x2704[2]. For general purpose use.
A	WAKE	Indicates when a WAKE event has occurred.
B	MUX_SYNC	Internal multiplexer frame SYNC signal. See Figure 4 and Figure 5 .
C	MCK	See 2.5.3 on page 47 .
E	GNDD	Digital GND. Use this signal to make the TMUX2OUT pin static.
12	INT0 – DIG I/O	Interrupt 0. See 2.4.8 on page 37 . Also see Figure 12 on page 44 .
13	INT1 – DIG I/O	
14	INT2 – CE_PULSE	
15	INT3 – CE_BUSY	
16	INT4 - VSTAT	
17	INT5 – EEPROM/SPI	
18	INT6 – XFER, RTC	
1F	RTM_CK (flash)	See 2.3.5 on page 25 .
Note: All <i>TMUX2[4:0]</i> values which are not shown are reserved.		

3 FUNCTIONAL DESCRIPTION

3.1 Theory of Operation

The energy delivered by a power source into a load can be expressed as:

$$E = \int_0^t V(t)I(t)dt$$

Assuming phase angles are constant, the following formulae apply:

$$P = \text{Real Energy [Wh]} = V * A * \cos \phi$$

$$Q = \text{Reactive Energy [VARh]} = V * A * \sin \phi$$

$$S = \text{Apparent Energy [VAh]} = \sqrt{P^2 + Q^2}$$

For a practical meter, not only voltage and current amplitudes, but also phase angles and harmonic content may change constantly. Thus, simple RMS measurements are inherently inaccurate. A modern solid-state electricity meter IC such as the 71M6545/H functions by emulating the integral operation above, i.e. it processes current and voltage samples through an ADC at a constant frequency. As long as the ADC resolution is high enough and the sample frequency is beyond the harmonic range of interest, the current and voltage samples, multiplied with the time period of sampling yields an accurate quantity for the momentary energy. Summing-up the momentary energy quantities over time results in accumulated energy.

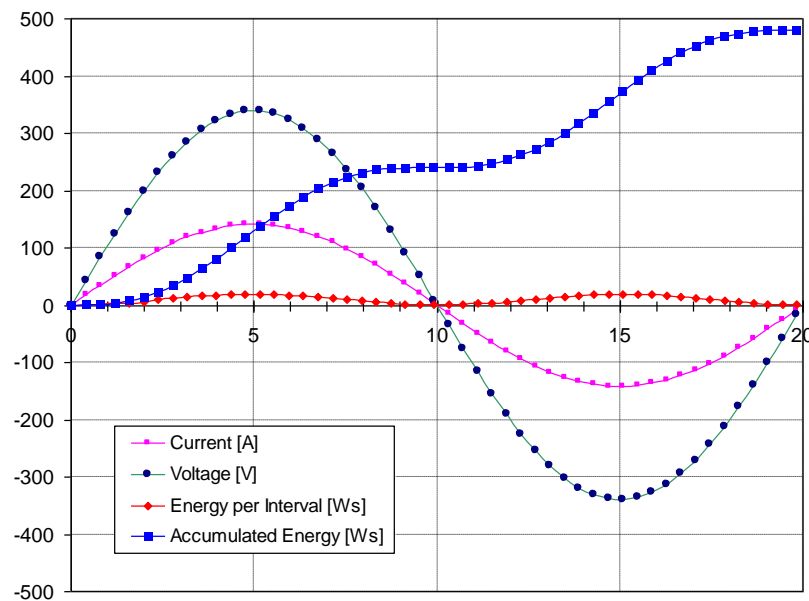

Figure 21: Voltage, Current, Momentary and Accumulated Energy

Figure 21 shows the shapes of $V(t)$, $I(t)$, the momentary power and the accumulated power, resulting from 50 samples of the voltage and current signals over a period of 20 ms. The application of 240 VAC and 100 A results in an accumulation of 480 Ws (= 0.133 Wh) over the 20 ms period, as indicated by the accumulated power curve. The described sampling method works reliably, even in the presence of dynamic phase shift and harmonic distortion.

3.2 SLP Mode (Sleep Mode)

Shortly after system power (V3P3SYS) is applied, the part will be in mission mode (MSN mode). MSN mode means that the part is operating with system power and that the internal PLL is stable. This mode is the normal operation mode where the part is capable of measuring energy.

When system power is not available, the 71M6545/H will be in SLP mode, if a battery is attached to the VBAT_RTC pin.

Shortly after system power is removed ($V3P3SYS < 3.0$ VDC), $VSTAT[2:0]$ will assume the value 001, issuing a warning to the MPU. The IC can still operate in this state, however, the analog functions are not considered accurate. Assuming that the recommended MPU setup code is resident in flash memory (see [2.4.1 MPU Setup Code](#) on page 29), at $V3P3SYS < 2.8$ VDC, the 71M6545/H will be forced to SLP mode by the MPU setting the *SLEEP* bit (*I/O RAM 0x28B2[7]*).

When system power is restored, the 71M6545/H will automatically transition from SLP mode back to MSN mode.

Table 55: Available Circuit Functions

Circuit Function	System Power	Battery Power
	MSN	SLP
CE	Yes	--
FIR	Yes	--
ADC, VREF	Yes	--
PLL	Yes	
Battery measurement	Yes	
Temperature sensor	Yes	Yes
Maximum MPU clock rate	4.92MHz (from PLL)	--
<i>MPU_DIV</i> clock divider	Yes	--
ICE	Yes	--
DIO Pins	Yes	--
Watchdog Timer	Yes	--
V3P3D Pin	Yes	--
VDD Pin	Yes	--
EEPROM Interface (2-wire)	Yes	--
EEPROM Interface (3-wire)	Yes	--
UART (full speed)	Yes	--
SPI slave port	Yes	--
SPI Special Flash Mode	Yes	--
Optical TX modulation	Yes	--
Flash Read	Yes	--
Flash Page Erase	Yes	--
Flash Write	Yes	--
RAM Read and Write	Yes	--
OSC and RTC	Yes	Yes
RAM data preservation	Yes	--
NV RAM data preservation	Yes	Yes

– indicates not active

The SLP mode may be commanded by the MPU whenever main system power is absent by asserting the *SLEEP* bit. The purpose of the SLP mode is to consume the least power while still maintaining the RTC, temperature compensation of the RTC, and the non-volatile portions of the I/O RAM.

In SLP mode, the V3P3D pin is disconnected, removing all sources of leakage from V3P3SYS. The non-volatile memory domain and the basic functions, such as temperature sensor, oscillator, and RTC, are powered by the VBAT_RTC input. In this mode, the I/O configuration bits and NV RAM values are preserved and RTC and oscillator continue to run. This mode can be exited only by system power up.

If the *SLEEP* bit is asserted when system power is present, the 71M6545/H will still enter SLP mode. It will drop WAKE, and then will begin the standard wake from sleep procedure.

After the transition from SLP mode to MSN mode the *PC* will be at 0x0000, the XRAM is in an undefined state, and the I/O RAM is only partially preserved (see the description of I/O RAM states in 5.2). The non-volatile sections of the I/O RAM are preserved unless RESET goes high.

The 71M6545/H features a temperature sensor and automatic digital temperature compensation circuitry that can operate from a battery connected to the VBAT_RTC pin, in the event of ac power loss. When ac power loss occurs, the 71M6545/H crystal oscillator, temperature sensor and digital temperature compensation circuitry automatically obtain power from the VBAT_RTC pin. See [2.5.4 Real-Time Clock \(RTC\)](#) on page 48.

3.3 Fault and Reset Behavior

3.3.1 Events at Power-Down

Power fault detection is performed by internal comparators that monitor the voltage at the V3P3A pin and also monitor the internally generated VDD pin voltage (2.5 VDC). The V3P3SYS and V3P3A pins must be tied together at the PCB level, so that the comparators, which are internally connected only to the V3P3A pin, are able to simultaneously monitor the common V3P3SYS and V3P3A pin voltage. The following discussion assumes that the V3P3A and V3P3SYS pins are tied together at the PCB level.

During a power failure, as V3P3A falls, two thresholds are detected:

The first threshold, at 3.0 VDC ($VSTAT[2:0] = 001$, $SFR\ 0xF9[2:0]$), warns the MPU that the analog modules are no longer accurate. Other than warning the MPU, the hardware takes no action when this threshold is crossed. This comparison produces an internal bit named *V3OKA*.

The second threshold, at 2.8 VDC, causes the 71M6545/H to switch to battery power. This switching happens while the FLASH and RAM systems are still able to read and write. This comparison produces an internal bit named *V3OK*.

The power quality is reflected by the $VSTAT[2:0]$ register in I/O RAM space, as shown in [Table 56](#). The $VSTAT[2:0]$ register is located at SFR address F9 and occupies bits 2:0. The $VSTAT[2:0]$ field can only be read.

In addition to the state of the main power, the $VSTAT[2:0]$ register provides information about the internal VDD voltage under battery power. Note that if system power (V3P3A) is above 2.8 VDC, the 71M6545/H always switches from battery to system power.

Table 56: $VSTAT[2:0]$ (SFR 0xF9[2:0])

$VSTAT[2:0]$	Description
000	System Power OK. $V3P3A > 3.0$ VDC. Analog modules are functional and accurate.
001	System Power is low. 2.8 VDC $< V3P3A < 3.0$ VDC. Analog modules not accurate.
010	VDD is OK. $VDD > 2.25$ VDC. The IC has full digital functionality.
011	2.25 VDC $> VDD > 2.0$ VDC. Flash write operations are inhibited.
101	$VDD < 2.0$, which means that the MPU is nearly out of voltage. A reset occurs in 4 cycles of the crystal clock CK32.

The response to a system power fault is almost entirely controlled by firmware. During a power failure, system power slowly falls. An interrupt notifies the MPU whenever $VSTAT[2:0]$ changes. It is the MPU's responsibility to reduce power, when necessary, by slowing the clock rate, disabling the PLL, etc.

Precision analog components such as the bandgap reference, the bandgap buffer, and the ADC are powered only by the V3P3A pin and become inaccurate and ultimately unavailable as the V3P3A pin voltage continues to drop (i.e., circuits powered by the V3P3A pin are not backed by the VBAT_RTC pin). When the V3P3A pin falls below 2.8 VDC, the ADC clocks are halted and the amplifiers are unbiased. Meanwhile, control bits such as ADC_E bit (I/O RAM $0x2704[4]$) are not affected, since their I/O RAM storage is powered from the VDD pin (2.5 VDC). The VDD pin is supplied with power through an internal 2.5 VDC regulator that is connected to the V3P3D pin. Note that the V3P3SYS and V3P3A pins are typically tied together at the PCB level.

3.3.2 Reset Sequence

When the RESET pin is pulled high, all digital activity in the chip stops, with the exception of the oscillator and RTC. Additionally, all I/O RAM bits are forced to their RST state. A reliable reset does not occur until

RESET has been high at least for 2 μ s. Note that TMUX and the RTC are not reset unless the TEST pin is pulled high while RESET is high.

The *RESET* control bit (*I/O RAM 0x 2200[3]*) performs an identical reset to the RESET pin except that a significantly shorter reset timer is used.

Once initiated, the reset sequence waits until the reset timer times out. The time out occurs in 4100 CE32 cycles (125 ms), at which time the MPU begins executing its pre-boot and boot sequences from address 0x0000. See 2.5.1.1 for a detailed description of the pre-boot and boot sequences.

A softer form of reset is initiated when the E_RST pin of the ICE interface is pulled low. This event causes the MPU and other registers in the MPU core to be reset but does not reset the remainder of the 71M6545/H. It does not trigger the reset sequence. This type of reset is intended to reset the MPU program, but not to make other changes to the chip's state.

3.4 Data Flow and Host Communication

The data flow between the Compute Engine (CE) and the host is shown in Figure 22. In a typical application, the 32-bit CE sequentially processes the samples from the voltage inputs on pins IADC0-IADC1, VADC8 (VA), IADC2-IADC3, etc., performing calculations to measure active power (Wh), reactive power (VARh), A^2h , and V^2h for four-quadrant metering. These measurements are then accessed by the host via the SPI interface, processed further and stored and/or displayed. For example, to obtain the RMS current value in phase A, the host reads the *IOSQSUM_X* register of the CE, scales it with *VMAX*, *IMAX*, and the LSB, as given in the CE Interface description (see 5.4 CE Interface Description on page 99), and then performs a square-root operation. Similarly, momentary real power and reactive power available via the *WSUM_X* and *VARSUM_X* registers only have to be scaled by the host, while the apparent power has to be post-processed as follows:

$$S = \sqrt{P^2 + Q^2}$$

Figure 22 illustrates the CE-to-host data flow.

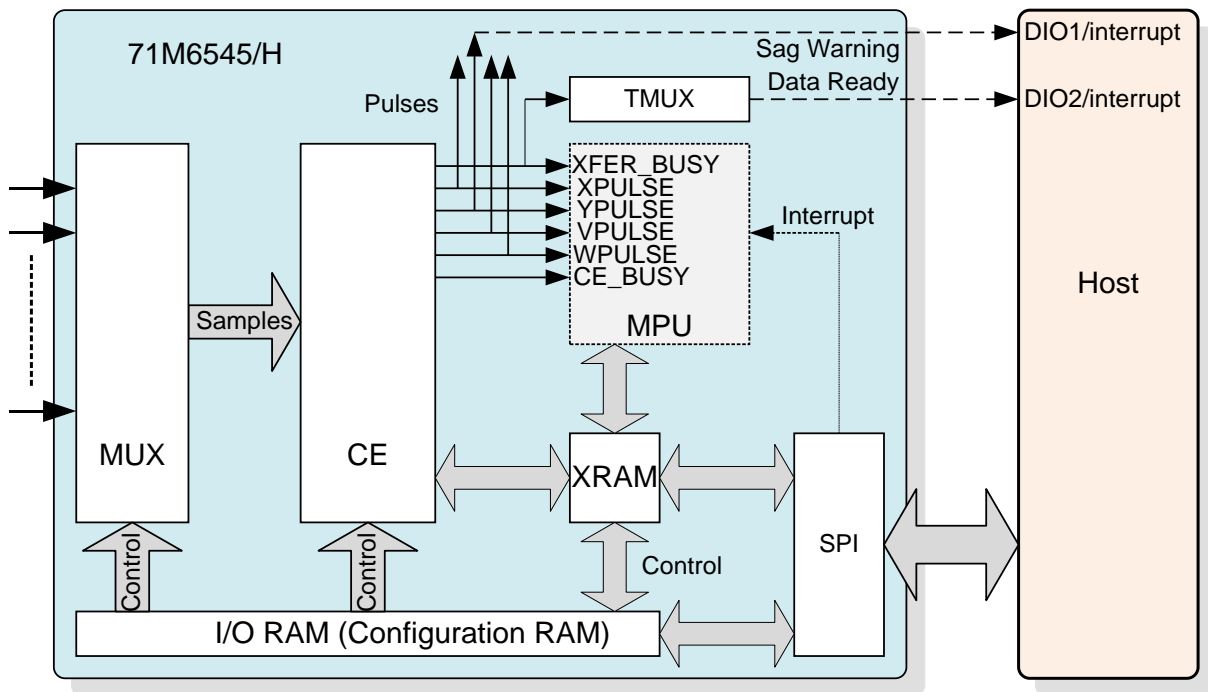

Figure 22: Data Flow

In addition to the four pulse interrupts XPULSE, YPULSE, VPULSE, and WPULSE, the CE outputs two interrupt signals: CE_BUSY and XFER_BUSY. XFER_BUSY signals the end of an accumulation interval

where data are ready for the host. This will occur whenever the CE has finished generating a sum by completing an accumulation interval as determined by the number of samples given in *SUM_SAMPS*. XFER_BUSY can be provided to the host via the test multiplexer output (TMUXOUT) to support synchronization. The YPULSE output can be used to signal a sag event to the host.

Refer to [5.4 CE Interface Description](#) on page 99 for additional information on setting up the device by the host.

For several reasons, it is necessary to have a small MPU program in flash memory, even when the host takes over all post-processing:

The MPU has to be prevented from executing code. With the flash mostly empty, the MPU will execute 0xFF op-codes until it runs into the CE code image. Executing the CE code image could have undesired results, e.g., changes to core I/O RAM settings, and must therefore be avoided. The host cannot access the SFRs of the MPU directly. However, SFR access is required for accessing the DIO pins. A small “driver” must exist to support SFR access, if the host needs to control the DIO pins.

Sample MPU code that performs the tasks described above is available from Silergy.

During operation, the host needs to trigger the watchdog reset periodically in order to avoid watchdog resets.

4 APPLICATION INFORMATION

4.1 Connecting 5 V Devices

All digital input pins of the 71M6545/H are compatible with external 5 V devices. I/O pins configured as inputs do not require current-limiting resistors when they are connected to external 5 V devices.

4.2 Directly Connected Sensors

Figure 23 through Figure 26 show voltage-sensing resistive dividers, current-sensing current transformers (CTs) and current-sensing resistive shunts and how they are connected to the voltage and current inputs of the 71M6545/H. All input signals to the 71M6545/H sensor inputs are voltage signals providing a scaled representation of either a sensed voltage or current.



The analog input pins of the 71M6545/H are designed for sensors with low source impedance. RC filters with resistance values higher than those implemented in the Demo Boards must not be used. Please refer to the Demo Board schematics for complete sensor input circuits and corresponding component values.

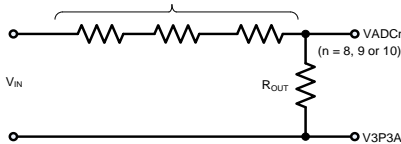

Figure 23: Resistive Voltage Divider (Voltage Sensing)

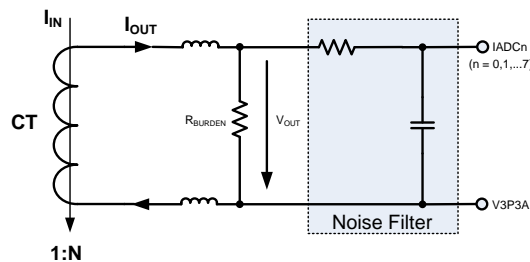

Figure 24: CT with Single-Ended Input Connection (Current Sensing)

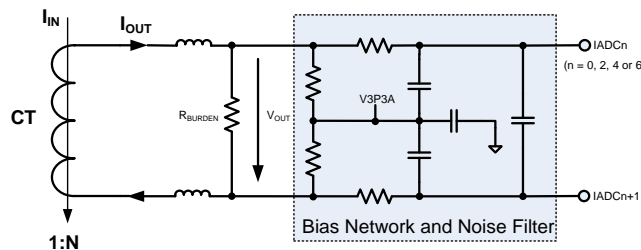

Figure 25: CT with Differential Input Connection (Current Sensing)

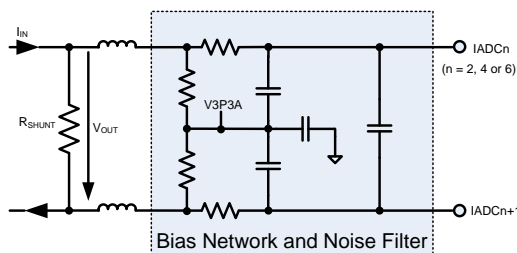

Figure 26: Differential Resistive Shunt Connections (Current Sensing)

4.3 Systems Using 71M6xx3 Isolated Sensors and Current Shunts

Figure 27 shows a typical connection for current shunt sensors; using the 71M6xx3 (poly-phase) isolated sensors. Note that one shunt current sensor is connected without isolation, which is the neutral current sensor in this example (connected to pins IADC0-IADC1). Each 71M6xx3 device is electrically isolated by a low-cost pulse transformer. The 71M6545/H current sensor inputs must be configured for remote sensor communications, as described in 2.2.8. Flexible remapping using the I/O RAM registers $MUXn_SEL[3:0]$ allows the sequence of analog input pins to be different from the standard configuration (a corresponding CE code must be used). See Figure 2 for the AFE configuration corresponding to Figure 27.

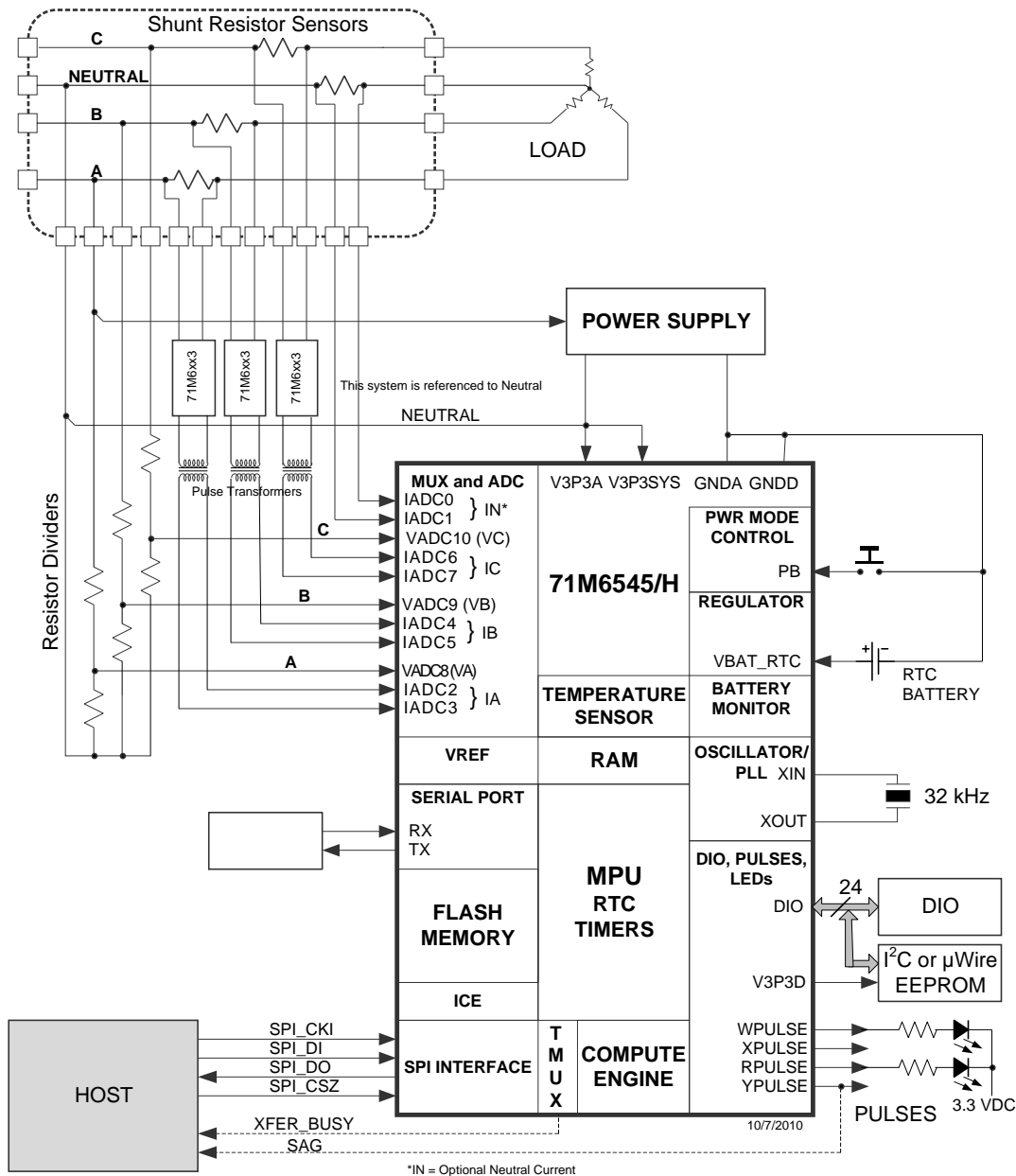

Figure 27: System Using Three-Remotes and One-Local (Neutral) Sensor

4.4 System Using Current Transformers

Figure 28 shows a poly-phase system using four current transformers to support optional Neutral current sensing for anti-tamper purposes. The Neutral current sensing CT can be omitted if Neutral current sensing is not required. The system is referenced to Neutral (i.e., the Neutral rail is tied to V3P3A and V3P3SYS).

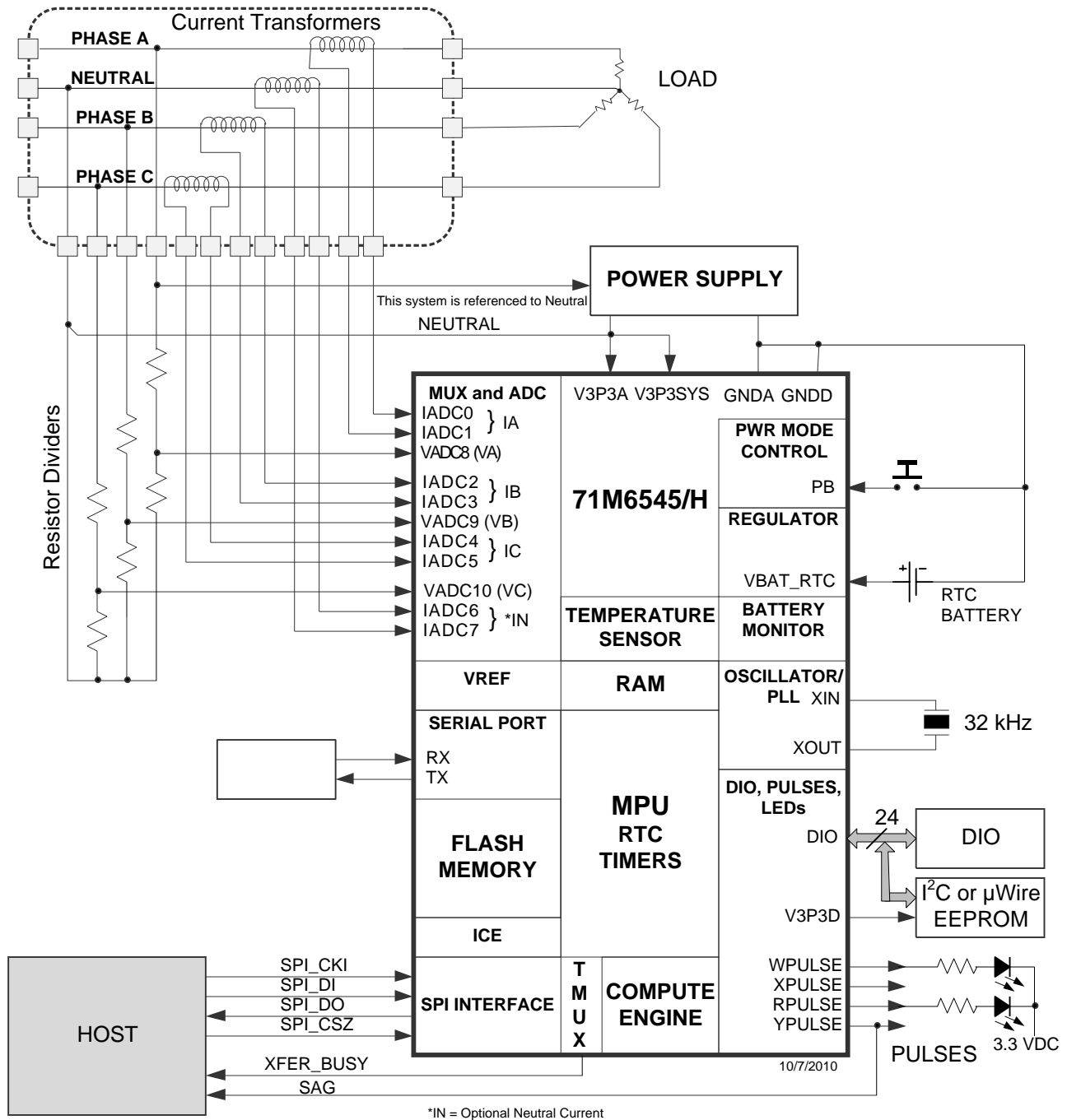

Figure 28. System Using Current Transformers

4.5 Metrology Temperature Compensation

4.5.1 Distinction Between Standard and High-Precision Parts

Since the VREF band-gap amplifier is chopper-stabilized, as set by the *CHOP_E[1:0]* (I/O RAM 0x2106[3:2]) control field, the dc offset voltage, which is the most significant long-term drift mechanism in the voltage references (VREF), is automatically removed by the chopper circuit. Both the 71M6545/H and the 71M6xx3 feature chopper circuits for their respective VREF voltage reference.

Since the variation in the bandgap reference voltage (VREF) is the major contributor to measurement error across temperatures, Silergy implements a two step procedure to trim and characterize the VREF voltage reference during the device manufacturing process.

The first step in the process is applied to both the 71M6545 and 71M6545H parts. In this first step, the reference voltage (VREF) is trimmed to a target value of 1.195V. During this trimming process, the *TRIMT[7:0]* (I/O RAM 0x2309) value is stored in non-volatile fuses. *TRIMT[7:0]* is trimmed to a value that results in minimum VREF variation with temperature.

For the 71M6545 device, the *TRIMT[7:0]* value can be read by the MPU during initialization in order to calculate parabolic temperature compensation coefficients suitable for each individual 71M6545 device. The resulting temperature coefficient for VREF in the 71M6545 is ± 40 ppm/°C.

Considering the factory calibration temperature of VREF to be +22°C and the industrial temperature range (-40°C to +85°C), the VREF error at the temperature extremes for the 71M6545 device can be calculated as:

$$\begin{aligned} & (85^{\circ}C - 22^{\circ}C) 40 \text{ ppm}/^{\circ}C \quad 2520 \text{ ppm} \quad 0.252\% \\ & \text{and} \\ & (-40^{\circ}C - 22^{\circ}C) 40 \text{ ppm}/^{\circ}C \quad 2480 \text{ ppm} \quad 0.248\% \end{aligned}$$

The above calculation implies that both the voltage and the current measurements are individually subject to a theoretical maximum error of approximately $\pm 0.25\%$. When the voltage sample and current sample are multiplied together to obtain the energy per sample, the voltage error and current error combine resulting in approximately $\pm 0.5\%$ maximum energy measurement error. However, this theoretical $\pm 0.5\%$ error considers only the voltage reference (VREF) as an error source. In practice, other error sources exist in the system. The principal remaining error sources are the current sensors (shunts or CTs) and their corresponding signal conditioning circuits, and the resistor voltage divider used to measure the voltage. The 71M6545 device should be used in Class 1% designs, to allow margin for the other error sources in the system.

The 71M6545H goes through an additional process of characterization during production which makes it suitable to high-accuracy applications. The additional process is the characterization of the voltage reference (VREF) over temperature. The coefficients for the voltage reference are stored in additional non-volatile trim fuses. The MPU can read these trim fuses during initialization and calculate parabolic temperature compensation coefficients suitable for each individual 71M6545H device. The resulting temperature coefficient for VREF in the 71M6545H is ± 10 ppm/°C.

The VREF error at the temperature extremes for the 71M6545H device can be calculated as:

$$\begin{aligned} & (85^{\circ}C - 22^{\circ}C) 10 \text{ ppm}/^{\circ}C \quad 630 \text{ ppm} \quad 0.063\% \\ & \text{and} \\ & (-40^{\circ}C - 22^{\circ}C) 10 \text{ ppm}/^{\circ}C \quad 620 \text{ ppm} \quad 0.062\% \end{aligned}$$

When the voltage sample and current sample are multiplied together to obtain the energy per sample, the voltage error and current error combine resulting in approximately $\pm 0.126\%$ maximum energy measurement error. The 71M6545H 0.1% grade device should be used in Class 0.2% and Class 0.5% designs, to allow margin for the other error sources in the system.

The preceding discussion in this section also applies to the 71M6603 (0.5%), 71M6113 (0.5%) and 71M6203 (0.1%) remote sensors.

4.5.2 Temperature Coefficients for the 71M6545

The equations provided below for calculating TC1 and TC2 apply to the 71M6545. In order to obtain TC1 and TC2, the MPU reads *TRIMT[7:0]* (I/O RAM 0x2309) and uses the TC1 and TC2 equations provided. PPMC and PPMC2 are then calculated from TC1 and TC2, as shown. The resulting tracking of the reference voltage (VREF) is within ±40 ppm/°C. See [4.5.1 Distinction Between Standard and High-Precision Parts](#).

$$TC1(V / C) = 275 + 4.95 TRIMT$$

$$TC2(V / C^2) = 0.557 + 0.00028 TRIMT$$

$$PPMC = 22.4632 TC1$$

$$PPMC2 = 1150.116 TC2$$

See [4.5.5](#) and [4.5.6](#) below for further temperature compensation details.

4.5.3 Temperature Coefficients for the 71M6545H

For the 71M6545H, undergoes a two-pass factory trimming process which stores additional trim fuse values. The additional trim fuse values characterize the device's VREF behavior at various temperatures. The values for TC1 and TC2 are calculated from the values read from the *TRIMT[7:0]* (I/O RAM 0x2309), *TRIMBGB[15:0]* (Info Page 0x92 and 0x93) and *TRIMBGD[7:0]* (Info Page 0x94) non-volatile on-chip fuses using the equations provided. The resulting tracking of the reference voltage is within ±10 ppm/°C, corresponding to a ±0.126% energy measurement accuracy. The equations for deriving PPCM and PPMC2 from TC1 and TC2 are also provided. See [4.5.1 Distinction Between Standard and High-Precision Parts](#).

$$TC1(\mu V / ^\circ C) = 35.091 + 0.01764 \cdot TRIMT + 1.587 \cdot \left(\frac{TRIMBGB[15:0]}{256} - \frac{TRIMBGD[7:0]}{128} \right)$$

$$TC2(V / C^2) = 0.557 + 0.00028 TRIMT$$

$$PPMC = 22.4632 TC1$$

$$PPMC2 = 1150.116 TC2$$

TRIMT[7:0] trims the VREF voltage for minimum variation with temperature. The *TRIMT[7:0]* fuses are read by the MPU directly at I/O RAM address 0x2309[7:0].

During the second pass trim for the 71M6545H, VREF is further characterized at 85°C and 22°C, and the resulting fuse trim values are stored in *TRIMBGB[15:0]* and *TRIMBGD[7:0]*, respectively. *TRIMBGB[15:0]* and *TRIMBGD[7:0]* cannot be read directly by the MPU. See [5.3 Reading the Info Page \(71M6545H only\)](#) on page [97](#) for information on how to read the Info Page trim fuses.

See [4.5.5](#) and [4.5.6](#) below for further temperature compensation details.

4.5.4 Temperature Coefficients for the 71M6603 and 71M6103 (1% Energy Accuracy)

Refer to the 71M6xxx Data sheet for the equations that are applicable to each 71M6xx3 part number and the corresponding temperature coefficients.

4.5.5 Temperature Compensation for VREF and Shunt Sensors

This section discusses metrology temperature compensation for the meter designs where current shunt sensors are used in conjunction with the 71M6xx3 remote isolated sensors, as shown in [Figure 27](#).

Sensors that are directly connected to the 71M6545/H are affected by the voltage variation in the 71M6545/H VREF due to temperature. On the other hand, shunt sensors that are connected to 71M6xx3 remote sensor are affected by the VREF in the 71M6xx3. The VREF in both the 71M6545/H and 71M6xx3 can be compensated digitally using a second-order polynomial function of temperature. The 71M6545/H and 71M6xx3 feature temperature sensors for the purposes of temperature compensating their corresponding VREF. The compensation computations must be implemented in MPU firmware.

Referring to [Figure 27](#), the VADC8 (VA), VADC9 (VB) and VADC10 (VC) voltage sensors are always directly connected to the 71M6545/H. Thus, the precision of the voltage sensors is primarily affected by VREF in the 71M6545/H. The temperature coefficient of the resistors used to implement the voltage dividers

for the voltage sensors (see [Figure 23](#)) determine the behavior of the voltage division ratio with respect to temperature. It is recommended to use resistors with low temperature coefficients, while forming the entire voltage divider using resistors belonging to the same technology family, in order to minimize the temperature dependency of the voltage division ratio. The resistors must also have suitable voltage ratings.

The 71M6545/H also may have one local current shunt sensor that is connected directly to it via the IADC0-IADC1 input pins, and therefore this local current sensor is also affected by the VREF in the 71M6545/H. The shunt current sensor resistance has a temperature dependency, which also may require compensation, depending on the required accuracy class.

The IADC2-IADC3, IADC4-IADC5 and IADC6-IADC7 current sensors are isolated by the 71M6xx3 and depend on the VREF of the 71M6xx3, plus the variation of the corresponding remote shunt current sensor with temperature.

The MPU has the responsibility of computing the necessary sample gain compensation values required for each sensor channel based on the sensed temperature. Silergy provides demonstration code that implements the $GAIN_ADJ_x$ compensation equation shown below. The resulting $GAIN_ADJ_x$ values are stored by the MPU in five CE RAM locations $GAIN_ADJ0$ - $GAIN_ADJ5$ (CE RAM $0x40$ - $0x44$). The demonstration code thus provides a suitable implementation of temperature compensation, but other methods are possible in MPU firmware by utilizing the on-chip temperature sensors while storing the sample gain adjustment results in the CE RAM $GAIN_ADJ_x$ storage locations for use by the CE. The demonstration code maintains five separate sets of $PPMC$ and $PPMC2$ coefficients and computes five separate $GAIN_ADJ_x$ values based on the sensed temperature using the equation below:

$$GAIN_ADJ_x = 16385 \frac{10 TEMP_X PPMC}{2^{14}} + \frac{100 TEMP_X^2 PPMC2}{2^{23}}$$

The $GAIN_ADJ_x$ values stored by the MPU in CE RAM are used by the CE to gain adjust (i.e., multiply) the sample in each corresponding sensor channel. A $GAIN_ADJ_x$ value of 16,384 (i.e., 2^{14}) corresponds to unity gain, while values less than 16,384 attenuate the samples and values greater than 16,384 amplify the samples.

In the above equation, $TEMP_X$ is the deviation from nominal or calibration temperature expressed in multiples of 0.1 °C. The 10x and 100x factors seen in the above equation are due to 0.1 °C scaling of $TEMP_X$. For example, if the calibration (reference) temperature is 22 °C and the measured temperature is 27 °C, then $10 * TEMP_X = (27-22) * 10 = 50$ (decimal), which represents a +5 °C deviation from 22 °C. In the demonstration code, $TEMP_X$ is calculated in the MPU from the $STEMP[10:0]$ temperature sensor reading using the equation provided below and is scaled in 0.1°C units. See [2.5.5 71M6545/H Temperature Sensor](#) on page 52 for the equation to calculate temperature in degrees °C from the $STEMP[10:0]$ value.

[Table 57](#) shows the five $GAIN_ADJ_x$ equation output storage locations and the voltage or current sensor channels for which they compensate for the 1 Local / 3 Remote configuration shown in [Figure 27](#).

Table 57: GAIN_ADJn Compensation Channels (Figure 2, Figure 27, Table 1)

Gain Adjustment Output	CE RAM Address	Sensor Channel(s) (pin names)	Compensation For:
$GAIN_ADJ0$	0x40	VADC8 (VA) VADC9 (VB) VADC10 (VC)	VREF in 71M6545/H and Voltage Divider Resistors
$GAIN_ADJ1$	0x41	IADC0-IADC1	VREF in 71M6545/H and Shunt (Neutral Current)
$GAIN_ADJ2$	0x42	IADC2-IADC3	VREF in 71M6xx3 and Shunt (Phase A)
$GAIN_ADJ3$	0x43	IADC4-IADC5	VREF in 71M6xx3 and Shunt (Phase B)
$GAIN_ADJ4$	0x44	IADC6-IADC7	VREF in 71M6xx3 and Shunt (Phase C)

In the demonstration code, the shape of the temperature compensation second-order parabolic curve is determined by the values stored in the $PPMC$ (1st order coefficient) and $PPMC2$ (2nd order coefficient), which are typically setup by the MPU at initialization time from values that are stored in EEPROM.

To disable temperature compensation in the demonstration code, *PPMC* and *PPMC2* are both set to zero for each of the five *GAIN_ADJ_x* channels. To enable temperature compensation, the *PPMC* and *PPMC2* coefficients are set with values that match the expected temperature variation of the shunt current sensor (if required) and the corresponding VREF voltage reference (summed together).

The shunt sensor requires a second order polynomial compensation which is determined by the *PPMC* and *PPMC2* coefficients for the corresponding current measurement channel. The corresponding VREF voltage reference also requires the *PPMC* and *PPMC2* coefficients to match the second order temperature behavior of the voltage reference. The *PPMC* and *PPMC2* values associated with the shunt and with the corresponding VREF are summed together to obtain the compensation coefficients for a given current-sensing channel (i.e., the 1st order *PPMC* coefficients are summed together, and the 2nd order *PPMC2* coefficients are summed together).

In the 71M6545, the required VREF compensation coefficients *PPMC* and *PPMC2* are calculated from readable on-chip non-volatile fuses (see [4.5.2 Temperature Coefficients for the 71M6545](#)). These coefficients are designed to achieve ± 40 ppm/°C for VREF in the 71M6545. *PPMC* and *PPMC2* coefficients are similarly calculated for the 71M6xx3 remote sensor (see [4.5.4](#)).

For the 71M6545H, coefficients specific to each individual device can be calculated from values read from additional on-chip fuses that characterize the VREF behavior of each individual part across industrial temperatures (see [4.5.3 Temperature Coefficients for the 71M6545H](#)). The resulting tracking of the reference VREF voltage is within ± 10 ppm/°C.

For the current channels, to determine the *PPMC* and *PPMC2* coefficients for the shunt current sensors, the designer must either know the average temperature curve of the shunt from its manufacturer's data sheet or obtain these coefficients by laboratory characterization of the shunt used in the design.

4.5.6 Temperature Compensation of VREF and Current Transformers

This section discusses metrology temperature compensation for meter designs where Current Transformer (CT) sensors are used, as shown in [Figure 28](#).

Sensors that are directly connected to the 71M6545/H are affected by the voltage variation in the 71M6545/H VREF due to temperature. The VREF in the 71M6545/H can be compensated digitally using a second-order polynomial function of temperature. The 71M6545/H features a temperature sensor for the purposes of temperature compensating its VREF. The compensation computations must be implemented in MPU firmware and written to the corresponding *GAIN_ADJ_x* CE RAM location.

Referring to [Figure 28](#), the VADC8 (VA), VADC9 (VB) and VADC10 (VC) voltage sensors are directly connected to the 71M6545/H. Thus, the precision of the voltage sensors is primarily affected by VREF in the 71M6545/H. The temperature coefficient of the resistors used to implement the voltage dividers for the voltage sensors (see [Figure 23](#)) determine the behavior of the voltage division ratio with respect to temperature. It is recommended to use resistors with low temperature coefficients, while forming the entire voltage divider using resistors belonging to the same technology family, in order to minimize the temperature dependency of the voltage division ratio. The resistors must also have suitable voltage ratings.

The Current Transformers are directly connected to the 71M6545/H and are therefore primarily affected by the VREF temperature dependency in the 71M6545/H. For best performance, it is recommended to use the differential signal conditioning circuit, as shown in [Figure 25](#), to connect the CTs to the 71M6545/H. Current transformers may also require temperature compensation. The copper wire winding in the CT has dc resistance with a temperature coefficient, which makes the voltage delivered to the burden resistor temperature dependent, and the burden resistor also has a temperature coefficient. Thus, each CT sensor channel needs to compensate for the 71M6545/H VREF, and optionally for the temperature dependency of the CT and its burden resistor depending on the required accuracy class.

The MPU has the responsibility of computing the necessary sample gain compensation values required for each sensor channel based on the sensed temperature. Silergy provides demonstration code that implements the *GAIN_ADJ_x* compensation equation shown below. The resulting *GAIN_ADJ_x* values are stored by the MPU in five CE RAM locations *GAIN_ADJ0-GAIN_ADJ5* (CE RAM 0x40-0x44). The demonstration code thus provides a suitable implementation of temperature compensation, but other methods are possible in MPU firmware by utilizing the on-chip temperature sensor while storing the sample gain adjustment results in the CE RAM *GAIN_ADJ_n* storage locations. The demonstration code maintains

five separate sets of *PPMC* and *PPMC2* coefficients and computes five separate *GAIN_ADJn* values based on the sensed temperature using the equation below:

$$GAIN_ADJ_x = 16385 \frac{10 TEMP_X PPMC}{2^{14}} \frac{100 TEMP_X^2 PPMC2}{2^{23}}$$

The *GAIN_ADJn* values stored by the MPU in CE RAM are used by the CE to gain adjust (i.e., multiply) the sample in each corresponding sensor channel. A *GAIN_ADJx* value of 16,384 (i.e., 2^{14}) corresponds to unity gain, while values less than 16,384 attenuate the samples and values greater than 16,384 amplify the samples.

In the above equation, *TEMP_X* is the deviation from nominal or calibration temperature expressed in multiples of 0.1 °C. The 10x and 100x factors seen in the above equation are due to 0.1 °C scaling of *TEMP_X*. For example, if the calibration (reference) temperature is 22 °C and the measured temperature is 27 °C, then $10 * TEMP_X = (27 - 22) * 10 = 50$ (decimal), which represents a +5 °C deviation from 22 °C. In the demonstration code, *TEMP_X* is calculated in the MPU from the *STEMP[10:0]* temperature sensor reading using the equation provided below and is scaled in 0.1°C units. See [2.5.5 71M6545/H Temperature Sensor](#) on page 52 for the equation to calculate temperature in °C from the *STEMP[10:0]* reading.

[Table 58](#) shows the five *GAIN_ADJx* equation output storage locations and the voltage or current measurements for which they compensate.

Table 58: GAIN_ADJx Compensation Channels (Figure 3, Figure 28, Table 2)

Gain Adjustment Output	CE RAM Address	Sensor Channel(s) (pin names)	Compensation For:
<i>GAIN_ADJ0</i>	0x40	VADC8 (VA) VADC9 (VB) VADC10 (VC)	VREF in 71M6545/H and Voltage Divider Resistors
<i>GAIN_ADJ1</i>	0x41	IADC0-IADC1	VREF in 71M6545/H, CT and Burden Resistor (Neutral Current)
<i>GAIN_ADJ2</i>	0x42	IADC2-IADC3	VREF in 71M6545/H, CT and Burden Resistor (Phase A)
<i>GAIN_ADJ3</i>	0x43	IADC4-IADC5	VREF in 71M6545/H, CT and Burden Resistor (Phase B)
<i>GAIN_ADJ4</i>	0x44	IADC6-IADC7	VREF in 71M6545/H, CT and Burden Resistor (Phase C)

In the demonstration code, the shape of the temperature compensation second-order parabolic curve is determined by the values stored in the *PPMC* (1st order coefficient) and *PPMC2* (2nd order coefficient), which are typically setup by the MPU at initialization time from values that are stored in EEPROM.

To disable temperature compensation in the demonstration code, *PPMC* and *PPMC2* are both set to zero for each of the five *GAIN_ADJx* channels. To enable temperature compensation, the *PPMC* and *PPMC2* coefficients are set with values that match the expected VREF temperature variation and optionally the corresponding sensor circuit (i.e., the CT and burden resistor for current channels or the resistor divider network for the voltage channels).

In the 71M6545, the required VREF compensation coefficients *PPMC* and *PPMC2* are calculated from readable on-chip non-volatile fuses (see [4.5.2 Temperature Coefficients for the 71M6545](#)). These coefficients are designed to achieve ±40 ppm/°C for VREF.

For the 71M6545H, coefficients specific to each individual device can be calculated from values read from additional on-chip fuses that characterize the VREF behavior of each individual part across industrial temperatures (see [4.5.3 Temperature Coefficients for the 71M6545H](#)). The resulting tracking of the reference VREF voltage is within ±10 ppm/°C.

4.6 Connecting I²C EEPROMs

I²C EEPROMs or other I²C compatible devices should be connected to the DIO pins DIO2 and DIO3, as shown in [Figure 29](#).

Pull-up resistors of roughly 10 k Ω to V3P3D should be used for both SDCK and SDATA signals. The *DIO_EEX (I/O RAM 0x2456[7:6])* field must be set to 01 in order to convert the DIO pins DIO2 and DIO3 to I²C pins SCL and SDATA.

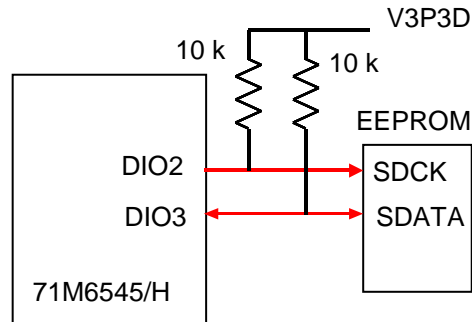

Figure 29: I²C EEPROM Connection

4.7 Connecting Three-Wire EEPROMs

μ Wire EEPROMs and other compatible devices should be connected to the DIO pins DIO2 and DIO3, as described in [2.5.11 EEPROM Interface](#) on page 56.

4.8 UART (TX/RX)

The UART0 RX pin should be pulled down by a 10 k Ω resistor and additionally protected by a 100 pF ceramic capacitor, as shown in [Figure 30](#).

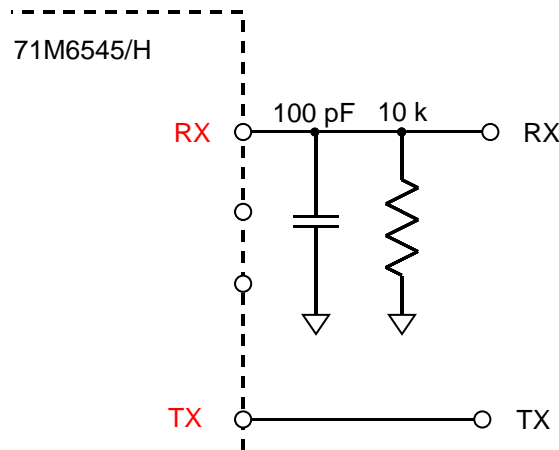

Figure 30: Connections for the UART

4.9 Connecting the Reset Pin

Even though a functional meter does not necessarily need a reset switch, it is useful to have a reset pushbutton for prototyping as shown in [Figure 31](#), left side. The RESET signal may be sourced from V3P3SYS.

✓ For a production meter, the RESET pin should be protected by the external components shown in [Figure 31](#), right side. R1 should be in the range of 100 Ω and mounted as closely as possible to the IC.

Since the 71M6545/H generates its own power-on reset, a reset button or circuitry, as shown in [Figure 31](#), is only required for test units and prototypes.

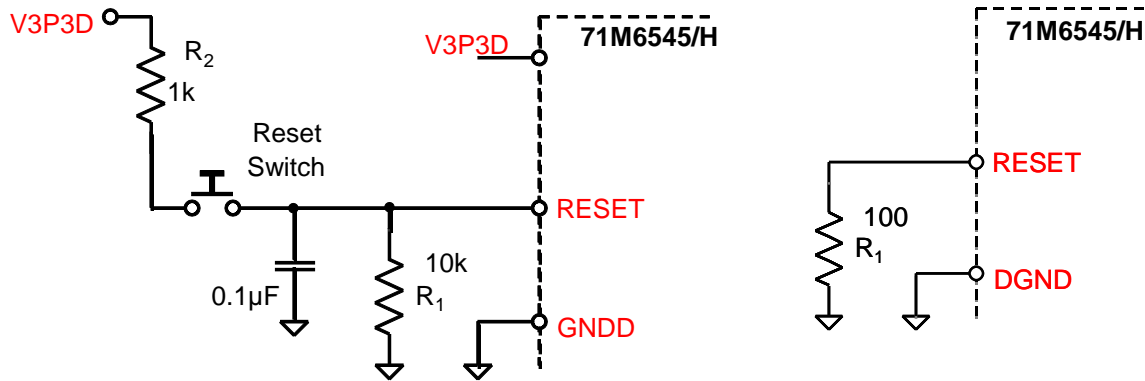

Figure 31: External Components for the RESET Pin: Push-Button (Left), Production Circuit (Right)

4.10 Connecting the Emulator Port Pins

Even when the emulator is not used, small shunt capacitors to ground (22 pF) should be used for protection from EMI as illustrated in Figure 32. Production boards should have the ICE_E pin connected to ground.

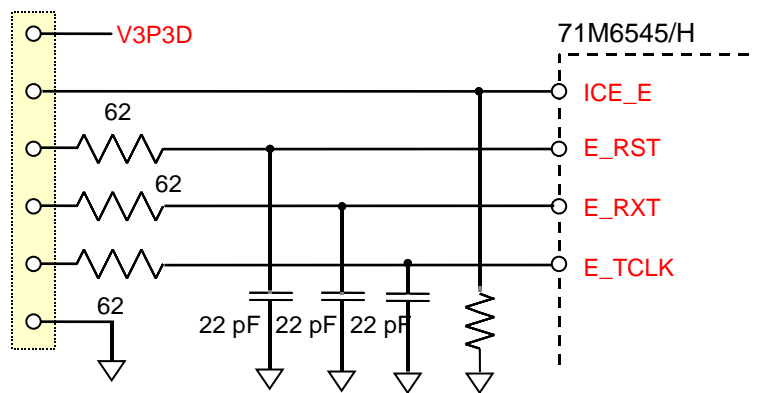

Figure 32: External Components for the Emulator Interface

4.11 Flash Programming

4.11.1 Flash Programming via the ICE Port

Operational or test code can be programmed into the flash memory using either an in-circuit emulator or the Flash Programmer Module (TFP-2) available from Silergy. The flash programming procedure uses the E_RST, E_RXTX, and E_TCLK pins.

4.11.2 Flash Programming via the SPI Port

It is possible to erase, read and program the flash memory of the 71M6545/H via the SPI port. See 2.5.12 for a detailed description.

4.12 MPU Demonstration Code

All application-specific MPU functions mentioned in 4 Application Information are featured in the demonstration C source code supplied by Silergy. The code is available as part of the Demonstration Kit for the 71M6545/H. The Demonstration Kits come with the 71M6545/H preprogrammed with demonstration firmware and mounted on a functional sample meter Demo Board. The Demo Boards allow for quick and efficient evaluation of the IC without having to write firmware or having to supply an in-circuit emulator (ICE).

4.13 Crystal Oscillator

The oscillator of the 71M6545/H drives a standard 32.768 kHz watch crystal. The oscillator has been designed specifically to handle these crystals and is compatible with their high impedance and limited power handling capability. The oscillator power dissipation is very low to maximize the lifetime of any battery backup device attached to the VBAT_RTC pin.

Board layouts with minimum capacitance from XIN to XOUT require less battery current. Good layouts have XIN and XOUT shielded from each other and also keep the XIN and XOUT traces short and away from digital signals.



Since the oscillator is self-biasing, an external resistor must not be connected across the crystal.

4.14 Meter Calibration

Once the 71M6545/H energy meter device has been installed in a meter system, it must be calibrated. A complete calibration includes the following:

- Establishment of the reference temperature for factory calibration (e.g., typically 22 °C).

- Calibration of the metrology section, i.e., calibration for errors of the current sensors, voltage dividers and signal conditioning components as well as of the internal reference voltage (VREF) at the reference temperature (e.g., typically 22 °C).

- Calibration of the oscillator frequency using the *RTCA_ADJ* register (*I/O RAM 0x2504*).

The metrology section can be calibrated using the gain and phase adjustment factors accessible to the CE. The gain adjustment is used to compensate for tolerances of components used for signal conditioning, especially the resistive components. Phase adjustment is provided to compensate for phase shifts introduced by the current sensors or by the effects of reactive power supplies.

Due to the flexibility of the MPU firmware, any calibration method, such as calibration based on energy, or current and voltage can be implemented. It is also possible to implement segment-wise calibration (depending on current range).

The 71M6545/H supports common industry standard calibration techniques, such as single-point (energy-only), multi-point (energy, Vrms, Irms), and auto-calibration.

Silergy provides a calibration spreadsheet file to facilitate the calibration process. Contact Silergy to obtain a copy of the latest calibration spreadsheet file for the 71M6545/H.

5 FIRMWARE INTERFACE

5.1 I/O RAM Map –Functional Order

In [Table 59](#) and [Table 60](#), unimplemented (U) and reserved (R) bits are shaded in light gray. Unimplemented bits are identified with a 'U'. Unimplemented bits have no memory storage, writing them has no effect, and reading them always returns zero. Reserved bits are identified with an 'R', and must always be written with a zero. Writing values other than zero to reserved bits may have undesirable side effects and must be avoided. Non-volatile bits are shaded in dark gray. Non-volatile bits are backed-up during power failures if the system includes a battery connected to the VBAT_RTC pin and the pin voltage is within specification.

The I/O RAM locations listed in [Table 59](#) have sequential addresses to facilitate reading by the MPU (e.g., in order to verify their contents). These I/O RAM locations are usually modified only at boot-up. The addresses shown in [Table 59](#) are an alternative sequential address to the addresses from [Table 60](#) which are used throughout this document. For instance, *EQU[2:0]* can be accessed at *I/O RAM 0x2000[7:5]* or at *I/O RAM 0x2106[7:5]*.

Table 59: I/O RAM Map – Functional Order, Basic Configuration

Name	Addr	Bit 7	Bit 6	Bit 5	Bit 4	Bit 3	Bit 2	Bit 1	Bit 0
CE6	2000	<i>EQU[2:0]</i>			U	<i>CHOP_E[1:0]</i>		<i>RTM_E</i>	<i>CE_E</i>
CE5	2001	U			<i>SUM_SAMPS[12:8]</i>				
CE4	2002	<i>SUM_SAMPS[7:0]</i>							
CE3	2003	U	U	<i>CE_LCTN[5:0]</i>					
CE2	2004	<i>PLS_MAXWIDTH[7:0]</i>							
CE1	2005	<i>PLS_INTERVAL[7:0]</i>							
CE0	2006	<i>DIFF6_E</i>	<i>DIFF4_E</i>	<i>DIFF2_E</i>	<i>DIFF0_E</i>	<i>RFLY_DIS</i>	<i>FIR_LEN[1:0]</i>		<i>PLS_INV</i>
RCE0	2007	<i>CHOPR[1:0]</i>		<i>RMT6_E</i>	<i>RMT4_E</i>	<i>RMT2_E</i>	<i>TMUXR6[2:0]</i>		
RTMUX	2008	U	<i>TMUXR4[2:0]</i>			U	<i>TMUXR2[2:0]</i>		
FOVRD	2009	U	U	R	U	U	U	U	U
MUX5	200A	<i>MUX_DIV[3:0]</i>				<i>MUX10_SEL</i>			
MUX4	200B	<i>MUX9_SEL</i>				<i>MUX8_SEL</i>			
MUX3	200C	<i>MUX7_SEL</i>				<i>MUX6_SEL</i>			
MUX2	200D	<i>MUX5_SEL</i>				<i>MUX4_SEL</i>			
MUX1	200E	<i>MUX3_SEL</i>				<i>MUX2_SEL</i>			
MUX0	200F	<i>MUX1_SEL</i>				<i>MUX0_SEL</i>			
TEMP	2010	R	<i>TEMP_PWR</i>	<i>OSC_COMP</i>	<i>TEMP_BAT</i>	U	<i>TEMP_PER[2:0]</i>		
DIO_R5	201B	U	U	U	U	U	<i>DIO_RPB[2:0]</i>		
DIO_R4	201C	U	<i>DIO_R11[2:0]</i>			U	<i>DIO_R10[2:0]</i>		
DIO_R3	201D	U	<i>DIO_R9[2:0]</i>			U	<i>DIO_R8[2:0]</i>		

Name	Addr	Bit 7	Bit 6	Bit 5	Bit 4	Bit 3	Bit 2	Bit 1	Bit 0
DIO_R2	201E	<i>U</i>	<i>DIO_R7[2:0]</i>			<i>U</i>	<i>DIO_R6[2:0]</i>		
DIO_R1	201F	<i>U</i>	<i>DIO_R5[2:0]</i>			<i>U</i>	<i>DIO_R4[2:0]</i>		
DIO_R0	2020	<i>U</i>	<i>DIO_R3[2:0]</i>			<i>U</i>	<i>DIO_R2[2:0]</i>		
DIO0	2021	<i>DIO_EEX[1:0]</i>		<i>U</i>	<i>U</i>	<i>R</i>	<i>R</i>	<i>R</i>	<i>R</i>
DIO1	2022	<i>DIO_PW</i>	<i>DIO_PV</i>	<i>R</i>	<i>R</i>	<i>U</i>	<i>R</i>	<i>R</i>	<i>R</i>
DIO2	2023	<i>DIO_PX</i>	<i>DIO_PY</i>	<i>U</i>	<i>U</i>	<i>U</i>	<i>U</i>	<i>U</i>	<i>U</i>
INT1_E	2024	<i>EX_EEX</i>	<i>EX_XPULSE</i>	<i>EX_YPULSE</i>	<i>EX_RTCT</i>	<i>U</i>	<i>EX_RTC1M</i>	<i>EX_RTC1S</i>	<i>EX_XFER</i>
INT2_E	2025	<i>EX_SPI</i>	<i>EX_WPULSE</i>	<i>EX_VPULSE</i>					
Reserved	2026				<i>R</i>	<i>R</i>	<i>R</i>	<i>R</i>	<i>R</i>
SFMM	2080	<i>SFMM[7:0]*</i>							
SFMS	2081	<i>SFMS[7:0]*</i>							

Notes:

**SFMM* and *SFMS* are accessible only through the SPI slave port. See [2.5.1.1 Flash Memory](#) for details.

Table 60 lists bits and registers that may have to be accessed on a frequent basis. Reserved bits have lighter gray background, and non-volatile bits have a darker gray background.

Table 60: I/O RAM Map – Functional Order

Name	Addr	Bit 7	Bit 6	Bit 5	Bit 4	Bit 3	Bit 2	Bit 1	Bit 0
CE and ADC									
MUX5	2100	<i>MUX_DIV[3:0]</i>			<i>MUX10_SEL[3:0]</i>				
MUX4	2101	<i>MUX9_SEL[3:0]</i>			<i>MUX8_SEL[3:0]</i>				
MUX3	2102	<i>MUX7_SEL[3:0]</i>			<i>MUX6_SEL[3:0]</i>				
MUX2	2103	<i>MUX5_SEL[3:0]</i>			<i>MUX4_SEL[3:0]</i>				
MUX1	2104	<i>MUX3_SEL[3:0]</i>			<i>MUX2_SEL[3:0]</i>				
MUX0	2105	<i>MUX1_SEL[3:0]</i>			<i>MUX0_SEL[3:0]</i>				
CE6	2106	<i>EQU[2:0]</i>		<i>U</i>	<i>CHOP_E[1:0]</i>	<i>RTM_E</i>		<i>CE_E</i>	
CE5	2107	<i>U</i>			<i>SUM_SAMPS[12:8]</i>				
CE4	2108	<i>SUM_SAMPS[7:0]</i>							
CE3	2109	<i>U</i>	<i>U</i>	<i>CE_LCTN[5:0]</i>					
CE2	210A	<i>PLS_MAXWIDTH[7:0]</i>							
CE1	210B	<i>PLS_INTERVAL[7:0]</i>							
CE0	210C	<i>DIFF6_E</i>	<i>DIFF4_E</i>	<i>DIFF2_E</i>	<i>DIFF0_E</i>	<i>RFLY_DIS</i>	<i>FIR_LEN[1:0]</i>		<i>PLS_INV</i>
RTM0	210D	<i>U</i>	<i>U</i>	<i>U</i>	<i>U</i>	<i>U</i>	<i>U</i>	<i>RTM0[9:8]</i>	
RTM0	210E	<i>RTM0[7:0]</i>							
RTM1	210F	<i>RTM1[7:0]</i>							
RTM2	2110	<i>RTM2[7:0]</i>							
RTM3	2111	<i>RTM3[7:0]</i>							
CLOCK GENERATION									
CKGN	2200	<i>U</i>	<i>U</i>	<i>ADC_DIV</i>	<i>PLL_FAST</i>	<i>RESET</i>	<i>MPU_DIV[2:0]</i>		
VREF TRIM FUSES									
TRIMT	2309	<i>TRIMT[7:0]</i>							
DIO									
DIO16	2420	<i>U</i>	<i>U</i>	<i>DIO16[5:0]</i>					
...	...	<i>U</i>	<i>U</i>	...					
DIO32	243D	<i>U</i>	<i>U</i>	<i>DIO45[5:0]</i>					
...	...	<i>U</i>	<i>U</i>	...					
DIO38	2443	<i>U</i>	<i>U</i>	<i>DIO51[5:0]</i>					
...	...	<i>U</i>	<i>U</i>	...					
DIO42	2447	<i>U</i>	<i>U</i>	<i>DIO55[5:0]</i>					

Name	Addr	Bit 7	Bit 6	Bit 5	Bit 4	Bit 3	Bit 2	Bit 1	Bit 0
DIO_R5	2450	U	R	R	R	U	DIO_RPB[2:0]		
DIO_R4	2451	U	DIO_R11[2:0]			U	DIO_R10[2:0]		
DIO_R3	2452	U	DIO_R9[2:0]			U	DIO_R8[2:0]		
DIO_R2	2453	U	DIO_R7[2:0]			U	DIO_R6[2:0]		
DIO_R1	2454	U	DIO_R5[2:0]			U	DIO_R4[2:0]		
DIO_R0	2455	U	DIO_R3[2:0]			U	DIO_R2[2:0]		
DIO0	2456	DIO_EEX[1:0]		U	U	R	R	R	R
DIO1	2457	DIO_PW	DIO_PV	R	R	U	R	R	R
DIO2	2458	DIO_PX	DIO_PY	U	U	U	U	U	U
NV BITS									
SPARENV	2500	U	U	U	U	R			
FOVRD	2501	U	U	R	U	U	U	U	U
TMUX	2502	U	U	TMUX[5:0]					
TMUX2	2503	U	U	U	TMUX2[4:0]				
RTC1	2504	U	RTCA_ADJ[6:0]						
71M6xx3 Interface									
REMOTE2	2602	RMT_RD[15:8]							
REMOTE1	2603	RMT_RD[7:0]							
RBITS									
INT1_E	2700	EX_EEX	EX_XPULSE	EX_YPULSE	EX_RTCT	U	EX_RTC1M	EX_RTC1S	EX_XFER
INT2_E	2701	EX_SPI	EX_WPULSE	EX_VPULSE	U	U	U	U	U
SECURE	2702	FLSH_UNLOCK[3:0]				R	FLSH_RDE	FLSH_WRE	R
Analog0	2704	VREF_CAL	VREF_DIS	PRE_E	ADC_E	BCURR	SPARE[2:0]		
VERSION	2706	VERSION[7:0]							
INTBITS	2707	U	INT6	INT5	INT4	INT3	INT2	INT1	INT0
FLAG0	SFR E8	IE_EEX	IE_XPULSE	IE_YPULSE	IE_RTCT	U	IE_RTC1M	IE_RTC1S	IE_XFER
FLAG1	SFR F8	IE_SPI	IE_WPULSE	IE_VPULSE	U	U	U	U	PB_STATE
STAT	SFR F9	U	U	U	PLL_OK	U	VSTAT[2:0]		
REMOTE0	SFR FC	U	PERR_RD	PERR_WR	RCMD[4:0]				
SPI1	SFR FD	SPI_CMD[7:0]							
SPI0	2708	SPI_STAT[7:0]							
RCE0	2709	CHOPR[1:0]		RMT6_E	RMT4_E	RMT2_E	TMUXR6[2:0]		
RTMUX	270A	U	TMUXR4[2:0]			U	TMUXR2[2:0]		

Name	Addr	Bit 7	Bit 6	Bit 5	Bit 4	Bit 3	Bit 2	Bit 1	Bit 0	
INFO_PG	270B	U	U	U	U	U	U	U	INFO_PG	
DIO3	270C	U	U	PORT_E	SPI_E	SPI_SAFE	U	U	U	
NV RAM and RTC										
NVRAM _{xx}	2800-287F	NVRAM[0] – NVRAM[7F] – Direct Access								
WAKE	2880	WAKE_TMR[7:0]								
STEMP1	2881	STEMP[10:3]								
STEMP0	2882	STEMP[2:0]			U	U	U	U	U	
BSENSE	2885	BSENSE[7:0]								
LKPADDR	2887	LKPAUTOI	LKPADDR[6:0]							
LKPDATA	2888	LKPDAT[7:0]								
LKPCTRL	2889	U	U	U	U	U	U	LKP_RD	LKP_WR	
RTC0	2890	RTC_WR	RTC_RD	U	RTC_FAIL	U	U	U	U	
RTC2	2892	RTC_SBSC[7:0]								
RTC3	2893	U	U	RTC_SEC[5:0]						
RTC4	2894	U	U	RTC_MIN[5:0]						
RTC5	2895	U	U	U	RTC_HR[4:0]					
RTC6	2896	U	U	U	U	U	RTC_DAY[2:0]			
RTC7	2897	U	U	U	RTC_DATE[4:0]					
RTC8	2898	U	U	U	U	RTC_MO[3:0]				
RTC9	2899	RTC_YR[7:0]								
RTC10	289B	U	U	U	U	U	RTC_P[16:14]			
RTC11	289C	RTC_P[13:6]								
RTC12	289D	RTC_P[5:0]						RTC_Q[1:0]		
RTC13	289E	U	U	RTC_TMIN[5:0]						
RTC14	289F	U	U	U	RTC_THR[4:0]					
TEMP	28A0	R	TEMP_PWR	OSC_COMP	TEMP_BAT	TBYTE_BUSY	TEMP_PER[2:0]			
Reserved	28B0	R	R	R	R	R	R	U	U	
Reserved	28B1	U	U	R	R	R	R	R	R	
MISC	28B2	SLEEP	R	R	U	U	U	U	U	
Reserved	28B3	U	U	U	R	R	R	R	R	
WDRST	28B4	WD_RST	TEMP_START	U	U	U	U	U	U	
MPU PORTS										

Name	Addr	Bit 7	Bit 6	Bit 5	Bit 4	Bit 3	Bit 2	Bit 1	Bit 0
PORT3	SFR B0	<i>DIO_DIR[15:12]</i>				<i>DIO[15:12]</i>			
PORT2	SFR A0	<i>DIO_DIR[11:8]</i>				<i>DIO[11:8]</i>			
PORT1	SFR 90	<i>DIO_DIR[7:4]</i>				<i>DIO[7:4]</i>			
PORT0	SFR 80	<i>DIO_DIR[3:0]</i>				<i>DIO[3:0]</i>			
FLASH									
ERASE	SFR 94	<i>FLSH_ERASE[7:0]</i>							
FLSHCTL	SFR B2	<i>PREBOOT</i>	<i>SECURE</i>	<i>U</i>	<i>U</i>	<i>FLSH_PEND</i>	<i>FLSH_PSTWR</i>	<i>FLSH_MEEN</i>	<i>FLSH_PWE</i>
PGADR	SFR B7	<i>FLSH_PGADR[6:0]</i>							<i>U</i>
PC									
EEDATA	SFR 9E	<i>EEDATA[7:0]</i>							
EECTRL	SFR 9F	<i>EECTRL[7:0]</i>							

5.2 I/O RAM Map – Alphabetical Order

Table 61 lists I/O RAM bits and registers in alphabetical order.

Bits with a write direction (W in column Dir) are written by the MPU into configuration RAM. Typically, they are initially stored in flash memory and copied to the configuration RAM by the MPU. Some of the more frequently programmed bits are mapped to the MPU SFR memory space. The remaining bits are mapped to the address space 0x2XXX. Bits with R (read) direction can be read by the MPU. Columns labeled Rst and Wk describe the bit values upon reset and wake, respectively. No entry in one of these columns means the bit is either read-only or is powered by the NV supply and is not initialized. Write-only bits return zero when they are read.

Locations that are shaded in grey are non-volatile (i.e., battery-backed).

Table 61: I/O RAM Map – Alphabetical Order

Name	Location	Rst	Wk	Dir	Description												
<i>ADC_E</i>	2704[4]	0	0	R/W	Enables ADC and VREF. When disabled, reduces bias current.												
<i>ADC_DIV</i>	2200[5]	0	0	R/W	<p><i>ADC_DIV</i> controls the rate of the ADC and FIR clocks. The <i>ADC_DIV</i> setting determines whether MCK is divided by 4 or 8: 0 = MCK/4 1 = MCK/8</p> <p>The resulting ADC and FIR clock is as shown below.</p> <table border="1"> <thead> <tr> <th></th> <th>PLL_FAST = 0</th> <th>PLL_FAST = 1</th> </tr> </thead> <tbody> <tr> <th>MCK</th> <td>6.291456 MHz</td> <td>19.660800 MHz</td> </tr> <tr> <th>ADC_DIV = 0</th> <td>1.572864 MHz</td> <td>4.9152 MHz</td> </tr> <tr> <th>ADC_DIV = 1</th> <td>0.786432 MHz</td> <td>2.4576 MHz</td> </tr> </tbody> </table>		PLL_FAST = 0	PLL_FAST = 1	MCK	6.291456 MHz	19.660800 MHz	ADC_DIV = 0	1.572864 MHz	4.9152 MHz	ADC_DIV = 1	0.786432 MHz	2.4576 MHz
	PLL_FAST = 0	PLL_FAST = 1															
MCK	6.291456 MHz	19.660800 MHz															
ADC_DIV = 0	1.572864 MHz	4.9152 MHz															
ADC_DIV = 1	0.786432 MHz	2.4576 MHz															
<i>BCURR</i>	2704[3]	0	0	R/W	Connects a 100 µA load to the battery (VBAT_RTC pin).												
<i>BSENSE</i> [7:0]	2885[7:0]	–	–	R	The result of the VBAT_RTC pin measurement. See 2.5.7 71M6545/H Battery Monitor on page 54.												
<i>CE_E</i>	2106[0]	0	0	R/W	CE enable.												
<i>CE_LCTN</i> [5:0]	2109[5:0]	31	31	R/W	CE program location. The starting address for the CE program is 1024* <i>CE_LCTN</i> .												
<i>CHIP_ID</i> [15:8] <i>CHIP_ID</i> [7:0]	2300[7:0] 2301[7:0]	0 0	0 0	R R	These bytes contain the chip identification.												
<i>CHOP_E</i> [1:0]	2106[3:2]	0	0	R/W	<p>Chop enable for the reference bandgap circuit. The value of CHOP changes on the rising edge of the internal MUXSYNC signal according to the value in <i>CHOP_E</i>[1:0]: 00 = toggle¹ 01 = positive 10 = reversed 11 = toggle</p> <p>¹except at the mux sync edge at the end of an accumulation interval.</p>												

Name	Location	Rst	Wk	Dir	Description																					
<i>CHOPR[1:0]</i>	2709[7:6]	00	00	R/W	The CHOP settings for the remote sensor. 00 = Auto chop. Change every MUX frame. 01 = Positive 10 = Negative 11 = Auto chop (same as 00)																					
<i>DIFF0_E</i>	210C[4]	0	0	R/W	Enables IADC0-IADC1 differential configuration.																					
<i>DIFF2_E</i>	210C[5]	0	0	R/W	Enables IADC2-IADC3 differential configuration.																					
<i>DIFF4_E</i>	210C[6]	0	0	R/W	Enables IADC4-IADC5 differential configuration.																					
<i>DIFF6_E</i>	210C[7]	0	0	R/W	Enables IADC6-IADC7 differential configuration.																					
<i>DIO_R2[2:0]</i> <i>DIO_R3[2:0]</i> <i>DIO_R4[2:0]</i> <i>DIO_R5[2:0]</i> <i>DIO_R6[2:0]</i> <i>DIO_R7[2:0]</i> <i>DIO_R8[2:0]</i> <i>DIO_R9[2:0]</i> <i>DIO_R10[2:0]</i> <i>DIO_R11[2:0]</i> <i>DIO_RPB[2:0]</i>	2455[2:0] 2455[6:4] 2454[2:0] 2454[6:4] 2453[2:0] 2453[6:4] 2452[2:0] 2452[6:4] 2451[2:0] 2451[6:4] 2450[2:0]	0 0 0 0 0 0 0 0 0 0 0		R/W	Connects PB and dedicated I/O pins DIO2 through DIO11 to internal resources. If more than one input is connected to the same resource, the MULTIPLE column below specifies how they are combined. <table border="1"> <thead> <tr> <th><i>DIO_Rx</i></th> <th>Resource</th> <th>MULTIPLE</th> </tr> </thead> <tbody> <tr> <td>0</td> <td>NONE</td> <td>–</td> </tr> <tr> <td>1</td> <td>Reserved</td> <td>OR</td> </tr> <tr> <td>2</td> <td>T0 (Timer0 clock or gate)</td> <td>OR</td> </tr> <tr> <td>3</td> <td>T1 (Timer1 clock or gate)</td> <td>OR</td> </tr> <tr> <td>4</td> <td>IO interrupt (int0)</td> <td>OR</td> </tr> <tr> <td>5</td> <td>IO interrupt (int1)</td> <td>OR</td> </tr> </tbody> </table>	<i>DIO_Rx</i>	Resource	MULTIPLE	0	NONE	–	1	Reserved	OR	2	T0 (Timer0 clock or gate)	OR	3	T1 (Timer1 clock or gate)	OR	4	IO interrupt (int0)	OR	5	IO interrupt (int1)	OR
<i>DIO_Rx</i>	Resource	MULTIPLE																								
0	NONE	–																								
1	Reserved	OR																								
2	T0 (Timer0 clock or gate)	OR																								
3	T1 (Timer1 clock or gate)	OR																								
4	IO interrupt (int0)	OR																								
5	IO interrupt (int1)	OR																								
<i>DIO_DIR[14:12]</i> <i>DIO_DIR[11:8]</i> <i>DIO_DIR[7:4]</i> <i>DIO_DIR[3:0]</i>	SFR B0[6:4] SFR A0[7:4] SFR 90[7:4] SFR 80[7:4]	F	F	R/W	Programs the direction of the first 15 DIO pins. 1 indicates output. See <i>DIO_PV</i> and <i>DIO_PW</i> for special option for DIO0 and DIO1 outputs. See <i>DIO_EEX[1:0]</i> for special option for DIO2 and DIO3. Note that the direction of DIO pins above 14 is set by <i>DIOx[1]</i> . See <i>PORT_E</i> to avoid power up spikes.																					
<i>DIO[14:12]</i> <i>DIO[11:8]</i> <i>DIO[7:4]</i> <i>DIO[3:0]</i>	SFR B0[3:0] SFR A0[3:0] SFR 90[3:0] SFR 80[3:0]	F	F	R/W	The value on the first 15 DIO pins. When written, changes data on pins configured as outputs. Pins as input ignore writes. Note that the data for DIO pins above 14 is set by <i>DIOx[0]</i> .																					
<i>DIO_EEX[1:0]</i>	2456[7:6]	0	–	R/W	When set, converts DIO3 and DIO2 to interface with external EEPROM. DIO2 becomes SDCK and DIO3 becomes bi-directional SDATA. <table border="1"> <thead> <tr> <th><i>DIO_EEX[1:0]</i></th> <th>Function</th> </tr> </thead> <tbody> <tr> <td>00</td> <td>Disable EEPROM interface</td> </tr> <tr> <td>01</td> <td>2-Wire EEPROM interface</td> </tr> <tr> <td>10</td> <td>3-Wire EEPROM interface</td> </tr> <tr> <td>11</td> <td>3-Wire EEPROM interface with separate DO (DIO3) and DI (DIO8) pins.</td> </tr> </tbody> </table>	<i>DIO_EEX[1:0]</i>	Function	00	Disable EEPROM interface	01	2-Wire EEPROM interface	10	3-Wire EEPROM interface	11	3-Wire EEPROM interface with separate DO (DIO3) and DI (DIO8) pins.											
<i>DIO_EEX[1:0]</i>	Function																									
00	Disable EEPROM interface																									
01	2-Wire EEPROM interface																									
10	3-Wire EEPROM interface																									
11	3-Wire EEPROM interface with separate DO (DIO3) and DI (DIO8) pins.																									

Name	Location	Rst	Wk	Dir	Description																								
<i>DIO_PV</i>	2457[6]	0	–	R/W	Causes VPULSE to be output on DIO1.																								
<i>DIO_PW</i>	2457[7]	0	–	R/W	Causes WPULSE to be output on DIO0.																								
<i>DIO_PX</i>	2458[7]	0	–	R/W	Causes XPULSE to be output on DIO6.																								
<i>DIO_PY</i>	2458[6]	0	–	R/W	Causes YPULSE to be output on DIO7.																								
<i>EEDATA[7:0]</i>	SFR 9E	0	0	R/W	Serial EEPROM interface data.																								
<i>EECTRL[7:0]</i>	SFR 9F	0	0	R/W	Serial EEPROM interface control.																								
					<table border="1"> <thead> <tr> <th>Status Bit</th> <th>Name</th> <th>Read/Write</th> <th>Reset State</th> <th>Polarity</th> <th>Description</th> </tr> </thead> <tbody> <tr> <td>7</td> <td><i>ERROR</i></td> <td>R</td> <td>0</td> <td>Positive</td> <td>1 when an illegal command is received.</td> </tr> <tr> <td>6</td> <td><i>BUSY</i></td> <td>R</td> <td>0</td> <td>Positive</td> <td>1 when serial data bus is busy.</td> </tr> <tr> <td>5</td> <td><i>RX_ACK</i></td> <td>R</td> <td>1</td> <td>Positive</td> <td>1 indicates that the EEPROM sent an ACK bit.</td> </tr> </tbody> </table>	Status Bit	Name	Read/Write	Reset State	Polarity	Description	7	<i>ERROR</i>	R	0	Positive	1 when an illegal command is received.	6	<i>BUSY</i>	R	0	Positive	1 when serial data bus is busy.	5	<i>RX_ACK</i>	R	1	Positive	1 indicates that the EEPROM sent an ACK bit.
					Status Bit	Name	Read/Write	Reset State	Polarity	Description																			
					7	<i>ERROR</i>	R	0	Positive	1 when an illegal command is received.																			
6	<i>BUSY</i>	R	0	Positive	1 when serial data bus is busy.																								
5	<i>RX_ACK</i>	R	1	Positive	1 indicates that the EEPROM sent an ACK bit.																								
<i>EQU[2:0]</i>	2106[7:5]	0	0	R/W	Specifies the power equation.																								
					<table border="1"> <thead> <tr> <th><i>EQU[2:0]</i></th> <th>Description</th> <th>Element 0</th> <th>Element 1</th> <th>Element 2</th> <th>Recommended MUX Sequence</th> </tr> </thead> <tbody> <tr> <td>3</td> <td>2 element, 4W, 3 Delta</td> <td>$VA(IA - IB)/2$</td> <td>0</td> <td>VC IC</td> <td>IA VA IB IC VC</td> </tr> <tr> <td>4</td> <td>2 element, 4W, 3 Wye</td> <td>$VA(IA-IB)/2$</td> <td>$VB(IC-IB)/2$</td> <td>0</td> <td>IA VA IB VB IC</td> </tr> <tr> <td>5*</td> <td>3 element, 4W, 3 Wye</td> <td>VA IA</td> <td>VB IB</td> <td>VC IC</td> <td>IA VA IB VB IC VC</td> </tr> </tbody> </table>	<i>EQU[2:0]</i>	Description	Element 0	Element 1	Element 2	Recommended MUX Sequence	3	2 element, 4W, 3 Delta	$VA(IA - IB)/2$	0	VC IC	IA VA IB IC VC	4	2 element, 4W, 3 Wye	$VA(IA-IB)/2$	$VB(IC-IB)/2$	0	IA VA IB VB IC	5*	3 element, 4W, 3 Wye	VA IA	VB IB	VC IC	IA VA IB VB IC VC
					<i>EQU[2:0]</i>	Description	Element 0	Element 1	Element 2	Recommended MUX Sequence																			
					3	2 element, 4W, 3 Delta	$VA(IA - IB)/2$	0	VC IC	IA VA IB IC VC																			
					4	2 element, 4W, 3 Wye	$VA(IA-IB)/2$	$VB(IC-IB)/2$	0	IA VA IB VB IC																			
5*	3 element, 4W, 3 Wye	VA IA	VB IB	VC IC	IA VA IB VB IC VC																								
					Note: *The available CE codes implements only equation 5. Contact Silergy to obtain CE code for equations 3 and 4.																								
<i>EX_XFER</i>	2700[0]	0	0	R/W	Interrupt enable bits. These bits enable the XFER_BUSY, the RTC_1SEC, etc. The bits are set by hardware and cannot be set by writing a 1. The bits are reset by writing 0. Note that if one of these interrupts is to be enabled, its corresponding 8051 EX enable bit must also be set. See 2.4.10 Interrupts , for details.																								
<i>EX_RTCIS</i>	2700[1]																												
<i>EX_RTCIM</i>	2700[2]																												
<i>EX_RTCT</i>	2700[3]																												
<i>EX_SPI</i>	2701[7]																												
<i>EX_EEX</i>	2700[7]																												
<i>EX_XPULSE</i>	2700[6]																												
<i>EX_YPULSE</i>	2700[5]																												
<i>EX_WPULSE</i>	2701[6]																												
<i>EX_VPULSE</i>	2701[5]																												

Name	Location	Rst	Wk	Dir	Description																
<i>FIR_LEN[1:0]</i>	210C[2:1]	0	0	R/W	<p>Determines the number of ADC cycles in the ADC decimation FIR filter.</p> <p><i>PLL_FAST</i> = 1:</p> <table border="1"> <thead> <tr> <th><i>FIR_LEN[1:0]</i></th> <th>ADC Cycles</th> </tr> </thead> <tbody> <tr> <td>00</td> <td>141</td> </tr> <tr> <td>01</td> <td>288</td> </tr> <tr> <td>10</td> <td>384</td> </tr> </tbody> </table> <p><i>PLL_FAST</i> = 0:</p> <table border="1"> <thead> <tr> <th><i>FIR_LEN[1:0]</i></th> <th>ADC Cycles</th> </tr> </thead> <tbody> <tr> <td>00</td> <td>135</td> </tr> <tr> <td>01</td> <td>276</td> </tr> <tr> <td>10</td> <td>Not Allowed</td> </tr> </tbody> </table> <p>The ADC LSB size and full-scale values depend on the <i>FIR_LEN[1:0]</i> setting. Refer to Table 73 on page 105 and Table 91 on page 120 for details.</p>	<i>FIR_LEN[1:0]</i>	ADC Cycles	00	141	01	288	10	384	<i>FIR_LEN[1:0]</i>	ADC Cycles	00	135	01	276	10	Not Allowed
<i>FIR_LEN[1:0]</i>	ADC Cycles																				
00	141																				
01	288																				
10	384																				
<i>FIR_LEN[1:0]</i>	ADC Cycles																				
00	135																				
01	276																				
10	Not Allowed																				
<i>FLSH_ERASE[7:0]</i>	SFR 94[7:0]	0	0	W	<p>Flash Erase Initiate</p> <p><i>FLSH_ERASE</i> is used to initiate either the Flash Mass Erase cycle or the Flash Page Erase cycle. Specific patterns are expected for <i>FLSH_ERASE</i> in order to initiate the appropriate Erase cycle. (default = 0x00).</p> <p>0x55 – Initiate Flash Page Erase cycle. Must be preceded by a write to <i>FLSH_PGADR[6:0]</i> (SFR 0xB7).</p> <p>0xAA – Initiate Flash Mass Erase cycle. Must be preceded by a write to <i>FLSH_MEEN</i> (SFR 0xB2) and the debug (CC) port must be enabled.</p> <p>Any other pattern written to <i>FLSH_ERASE</i> has no effect.</p>																
<i>FLSH_MEEN</i>	SFR B2[1]	0	0	W	<p>Mass Erase Enable</p> <p>0 = Mass Erase disabled (default).</p> <p>1 = Mass Erase enabled.</p> <p>Must be re-written for each new Mass Erase cycle.</p>																
<i>FLSH_PEND</i>	SFR B2[3]	0	0	R	<p>Indicates that a posted flash write is pending. If another flash write is attempted, it is ignored.</p>																
<i>FLSH_PGADR[6:0]</i>	SFR B7[7:1]	0	0	W	<p>Flash Page Erase Address</p> <p>Flash Page Address (page 0 thru 63) that is erased during the Page Erase cycle. (default = 0x00).</p> <p>Must be re-written for each new Page Erase cycle.</p>																
<i>FLSH_PSTWR</i>	SFR B2[2]	0	0	R/W	<p>Enables posted flash writes. When 1, and if <i>CE_E</i> = 1, flash write requests are stored in a one element deep FIFO and are executed when <i>CE_BUSY</i> falls. <i>FLSH_PEND</i> can be read to determine the status of the FIFO. If <i>FLSH_PSTWR</i> = 0 or if <i>CE_E</i> = 0, flash writes are immediate.</p>																

Name	Location	Rst	Wk	Dir	Description
<i>FLSH_PWE</i>	SFR B2[0]	0	0	R/W	<u>Program Write Enable</u> 0 = MOVX commands refer to External RAM Space, normal operation (default). 1 = MOVX @DPTR,A moves A to External Program Space (Flash) @ DPTR. This bit is automatically reset after each byte written to flash. Writes to this bit are inhibited when interrupts are enabled.
<i>FLSH_RDE</i>	2702[2]	–	–	R	Indicates that the flash may be read by ICE or SPI slave. <i>FLSH_RDE</i> = (! <i>SECURE</i>)
<i>FLSH_UNLOCK[3:0]</i>	2702[7:4]	0	0	R/W	Must be a 2 to enable any flash modification. See the description of Flash security for more details.
<i>FLSH_WRE</i>	2702[1]	–	–	R	Indicates that the flash may be written through ICE or SPI slave ports.
<i>IE_XFER</i> <i>IE_RTCIS</i> <i>IE_RTCIM</i> <i>IE_RTCT</i> <i>IE_SPI</i> <i>IE_EEX</i> <i>IE_XPULSE</i> <i>IE_YPULSE</i> <i>IE_WPULSE</i> <i>IE_VPULSE</i>	SFR E8[0] SFR E8[1] SFR E8[2] SFR E8[3] SFR F8[7] SFR E8[7] SFR E8[6] SFR E8[5] SFR F8[6] SFR F8[5]	0	0	R/W	Interrupt flags for external interrupts 2 and 6. These flags monitor the source of the int6 and int2 interrupts (external interrupts to the MPU core). These flags are set by hardware and must be cleared by the software interrupt handler. The <i>IEX2</i> (<i>SFR 0xC0[1]</i>) and <i>IEX6</i> (<i>SFR 0xC0[5]</i>) interrupt flags are automatically cleared by the MPU core when it vectors to the interrupt handler. <i>IEX2</i> and <i>IEX6</i> must be cleared by writing zero to their corresponding bit positions in SFR 0xC0, while writing ones to the other bit positions that are not being cleared.
<i>INTBITS</i>	2707[6:0]	–	–	R	Interrupt inputs. The MPU may read these bits to see the input to external interrupts INT0, INT1, up to INT6. These bits do not have any memory and are primarily intended for debug use.
<i>LKPADDR[6:0]</i>	2887[6:0]	0	0	R/W	The address for reading and writing the RTC lookup RAM.
<i>LKPAUTOI</i>	2887[7]	0	0	R/W	Auto-increment flag. When set, <i>LKPADDR[6:0]</i> auto increments every time <i>LKP_RD</i> or <i>LKP_WR</i> is pulsed. The incremented address can be read at <i>LKPADDR</i> .
<i>LKPDAT[7:0]</i>	2888[7:0]	0	0	R/W	The data for reading and writing the RTC lookup RAM.
<i>LKP_RD</i> <i>LKP_WR</i>	2889[1] 2889[0]	0 0	0 0	R/W R/W	Strobe bits for the RTC lookup RAM read and write. When set, the <i>LKPADDR[6:0]</i> and <i>LKPDAT</i> registers is used in a read or write operation. When a strobe is set, it stays set until the operation completes, at which time the strobe is cleared and <i>LKPADDR[6:0]</i> is incremented if <i>LKPAUTOI</i> is set.
<i>MPU_DIV[2:0]</i>	2200[2:0]	0	0	R/W	MPU clock rate is: $\text{MPU Rate} = \text{MCK Rate} * 2^{-(2+\text{MPU_DIV}[2:0])}$ The maximum value for <i>MPU_DIV[2:0]</i> is 4. Based on the default values of the <i>PLL_FAST</i> bit and <i>MPU_DIV[2:0]</i> , the power up MPU rate is 4.92MHz * ¼ = 1.23 MHz. The minimum MPU clock rate is 38.4 kHz when <i>PLL_FAST</i> = 1.
<i>MUX0_SEL[3:0]</i>	2105[3:0]	0	0	R/W	Selects which ADC input is to be converted during time slot 0.
<i>MUX1_SEL[3:0]</i>	2105[7:4]	0	0	R/W	Selects which ADC input is to be converted during time slot 1.

Name	Location	Rst	Wk	Dir	Description
<i>MUX2_SEL[3:0]</i>	2104[3:0]	0	0	R/W	Selects which ADC input is to be converted during time slot 2.
<i>MUX3_SEL[3:0]</i>	2104[7:4]	0	0	R/W	Selects which ADC input is to be converted during time slot 3.
<i>MUX4_SEL[3:0]</i>	2103[3:0]	0	0	R/W	Selects which ADC input is to be converted during time slot 4.
<i>MUX5_SEL[3:0]</i>	2103[7:4]	0	0	R/W	Selects which ADC input is to be converted during time slot 5.
<i>MUX6_SEL[3:0]</i>	2102[3:0]	0	0	R/W	Selects which ADC input is to be converted during time slot 6.
<i>MUX7_SEL[3:0]</i>	2102[7:4]	0	0	R/W	Selects which ADC input is to be converted during time slot 7.
<i>MUX8_SEL[3:0]</i>	2101[3:0]	0	0	R/W	Selects which ADC input is to be converted during time slot 8.
<i>MUX9_SEL[3:0]</i>	2101[7:4]	0	0	R/W	Selects which ADC input is to be converted during time slot 9.
<i>MUX10_SEL[3:0]</i>	2100[3:0]	0	0	R/W	Selects which ADC input is to be converted during time slot 10.
<i>MUX_DIV[3:0]</i>	2100[7:4]	0	0	R/W	<i>MUX_DIV[3:0]</i> is the number of ADC time slots in each MUX frame. The maximum number of time slots is 11.
<i>Reserved</i>	2457[0]	0	–	R/W	Reserved. Must be 0.
<i>Reserved</i>	2457[5:4]	00	–	R/W	Reserved. Must be 00.
<i>DIO55_EN</i>	2457[2]	0	–	R/W	Enables DIO55 <i>DIO55_EN</i> = 0: DIO55 is disabled <i>DIO55_EN</i> = 1: DIO55 is enabled
<i>Reserved</i>	2457[1]	0	–	R/W	Reserved. Must be 0.
<i>Reserved</i>	2456[3:0]	0000	–	R/W	Reserved. Must be 0000.
<i>OSC_COMP</i>	28A0[5]	0	–	R/W	Enables the automatic update of <i>RTC_P[16:0]</i> and <i>RTC_Q [1:0]</i> every time the temperature is measured.
<i>PB_STATE</i>	SFR F8[0]	0	0	R	The de-bounced state of the PB pin.
<i>PERR_RD</i> <i>PERR_WR</i>	SFR FC[6] SFR FC[5]	0	0	R/W	The 71M6545/H sets these bits to indicate that a parity error on the remote sensor has been detected. Once set, the bits are remembered until they are cleared by the MPU.
<i>PLL_OK</i>	SFR F9[4]	0	0	R	Indicates that the clock generation PLL is settled.
<i>PLL_FAST</i>	2200[4]	0	0	R/W	Controls the speed of the PLL and MCK. 1 = 19.66 MHz (XTAL * 600) 0 = 6.29 MHz (XTAL * 192)
<i>PLS_MAXWIDTH[7:0]</i>	210A[7:0]	FF	FF	R/W	Determines the maximum width of the pulse (low-going pulse). Maximum pulse width is $(2 * PLS_MAXWIDTH + 1) * T_i$. Where T_i is <i>PLS_INTERVAL</i> . If <i>PLS_INTERVAL</i> = 0 or <i>PLS_MAXWIDTH</i> = 255, no width checking is performed and the output pulses have 50% duty cycle.

Name	Location	Rst	Wk	Dir	Description
<i>PLS_INTERVAL[7:0]</i>	210B[7:0]	0	0	R/W	Determines the Interval time. The time between FIFO outputs is <i>PLS_INTERVAL[7:0]*4*203ns</i> . If <i>PLS_INTERVAL[7:0] = 0</i> , the FIFO is not used and pulses are output as soon as the CE issues them. Assuming a that the CE code is written to generate 6 pulses in one integration interval, when the FIFO is enabled (i.e., <i>PLS_INTERVAL[7:0] = 0</i>) and <i>SUM_SAMPS = 2520</i> , <i>PLS_INTERVAL[7:0]</i> must be written with 81 so that the six pulses are evenly spaced in time over the integration interval and the last pulse is issued just prior to the end of the interval.
<i>PLS_INV</i>	210C[0]	0	0	R/W	Inverts the polarity of WPULSE, VARPULSE, XPULSE, and YPULSE. Normally, these pulses are active low. When inverted, they become active high.
<i>PORT_E</i>	270C[5]	0	0	R/W	Enables outputs from the DIO0-DIO14 pins. <i>PORT_E = 0</i> blocks the momentary output pulse that occurs when DIO0-DIO14 are reset on power up.
<i>PRE_E</i>	2704[5]	0	0	R/W	Enables the 8x pre-amplifier.
<i>PREBOOT</i>	SFRB2[7]	–	–	R	Indicates that pre-boot sequence is active.
<i>RCMD[4:0]</i>	SFR FC[4:0]	0	0	R/W	When the MPU writes a non-zero value to <i>RCMD</i> , the 71M6545/H issues a command to the appropriate remote sensor. When the command is complete, the 71M6545/H clears <i>RCMD</i> .
<i>RESET</i>	2200[3]	0	0	W	When set, causes a reset.
<i>RFLY_DIS</i>	210C[3]	0	0	R/W	Controls how the 71M6545/H drives the power pulse for the 71M6xxx. When set, the power pulse is driven high and low. When cleared, it is driven high followed by an open circuit flyback interval.
<i>RMT2_E</i> <i>RMT4_E</i> <i>RMT6_E</i>	2709[3] 2709[4] 2709[5]	0	0	R/W	Enables the remote interface.
<i>RMT_RD[15:8]</i> <i>RMT_RD[7:0]</i>	2602[7:0] 2603[7:0]	0	0	R	Response from remote read request.
<i>RTCA_ADJ[6:0]</i>	2504[6:0]	40	–	R/W	Register for analog RTC frequency adjustment.
<i>RTC_FAIL</i>	2890[4]	0	0	R/W	Indicates that a count error has occurred in the RTC and that the time is not trustworthy. This bit can be cleared by writing a 0.
<i>RTC_P[16:14]</i> <i>RTC_P[13:6]</i> <i>RTC_P[5:0]</i>	289B[2:0] 289C[7:0] 289D[7:2]	4 0 0	4 0 0	R/W	RTC adjust. See 2.5.4 Real-Time Clock (RTC) . 0x0FFBF <i>RTC_P</i> 0x10040 Note: <i>RTC_P[16:0]</i> and <i>RTC_Q[1:0]</i> form a single 19-bit RTC adjustment value.
<i>RTC_Q[1:0]</i>	289D[1:0]	0	0	R/W	RTC adjust. See 2.5.4 Real-Time Clock (RTC) . Note: <i>RTC_P[16:0]</i> and <i>RTC_Q[1:0]</i> form a single 19-bit RTC adjustment value.
<i>RTC_RD</i>	2890[6]	0	0	R/W	Freezes the RTC shadow register so it is suitable for MPU reads. When <i>RTC_RD</i> is read, it returns the status of the shadow register: 0 = up to date, 1 = frozen.
<i>RTC_SBSC[7:0]</i>	2892[7:0]	–	–	R	Time remaining since the last 1 second boundary. LSB=1/128 second.

Name	Location	Rst	Wk	Dir	Description
<i>RTC_TMIN[5:0]</i>	289E[5:0]	0	–	R/W	The target minutes register. See <i>RTC_THR</i> below.
<i>RTC_THR[4:0]</i>	289F[4:0]	0	–	R/W	The target hours register. The <i>RTC_T</i> interrupt occurs when <i>RTC_MIN</i> [5:0] becomes equal to <i>RTC_TMIN</i> [5:0] and <i>RTC_HR</i> [4:0] becomes equal to <i>RTC_THR</i> [4:0].
<i>RTC_WR</i>	2890[7]	0	0	R/W	Freezes the RTC shadow register so it is suitable for MPU writes. When <i>RTC_WR</i> is cleared, the contents of the shadow register are written to the RTC counter on the next RTC clock (~1 kHz). When <i>RTC_WR</i> is read, it returns 1 as long as <i>RTC_WR</i> is set. It continues to return one until the RTC counter actually updates.
<i>RTC_SEC</i> [5:0] <i>RTC_MIN</i> [5:0] <i>RTC_HR</i> [4:0] <i>RTC_DAY</i> [2:0] <i>RTC_DATE</i> [4:0] <i>RTC_MO</i> [3:0] <i>RTC_YR</i> [7:0]	2893[5:0] 2894[5:0] 2895[4:0] 2896[2:0] 2897[4:0] 2898[3:0] 2899[7:0]	– – – – – – –	– – – – – – –	R/W	The RTC interface. These are the year, month, day, hour, minute and second parameters for the RTC. The RTC is set by writing to these registers. Year 00 and all others divisible by 4 are defined as a leap year. SEC 00 to 59 MIN 00 to 59 HR 00 to 23 (00=Midnight) DAY 01 to 07 (01=Sunday) DATE 01 to 31 MO 01 to 12 YR 00 to 99 Each write operation to one of these registers must be preceded by a write to 0x20A0.
<i>RTM_E</i>	2106[1]	0	0	R/W	Real Time Monitor enable. When 0, the RTM output is low.
<i>RTM0</i> [9:8] <i>RTM0</i> [7:0] <i>RTM1</i> [7:0] <i>RTM2</i> [7:0] <i>RTM3</i> [7:0]	210D[1:0] 210E[7:0] 210F[7:0] 2110[7:0] 2111[7:0]	0 0 0 0 0	0 0 0 0 0	R/W	Four RTM probes. Before each CE code pass, the values of these registers are serially output on the RTM pin. The RTM registers are ignored when <i>RTM_E</i> = 0. Note that <i>RTM0</i> is 10 bits wide. The others assume the upper two bits are 00.
<i>SECURE</i>	SFR B2[6]	0	0	R/W	Inhibits erasure of page 0 and flash memory addresses above the beginning of CE code as defined by <i>CE_LCTN</i> [5:0]. Also inhibits the reading of flash memory by external devices (SPI or ICE port).
<i>SLEEP</i>	28B2[7]	0	0	W	Puts the 71M6545/H to sleep. Ignored if system power is present. The 71M6545/H wakes when the Wake timer times out, when push button is pushed, or when system power returns.
<i>SPI_CMD</i>	SFR FD[7:0]	–	–	R	SPI command. 8-bit command from the bus master.
<i>SPI_E</i>	270C[4]	1	1	R/W	SPI port enable. Enables the SPI interface on pins <i>SPI_DI</i> , <i>SPI_DO</i> , <i>SPI_CSZ</i> and <i>SPI_CKI</i> .
<i>SPI_SAFE</i>	270C[3]	0	0	R/W	Limits SPI writes to <i>SPI_CMD</i> and a 16 byte region in DRAM. No other writes are permitted.

Name	Location	Rst	Wk	Dir	Description								
<i>SPI_STAT</i>	2708[7:0]	0	0	R	<p><i>SPI_STAT</i> contains the status results from the previous SPI transaction</p> <p>Bit 7 - 71M6545/H ready error: the 71M6545/H was not ready to read or write as directed by the previous command.</p> <p>Bit 6 - Read data parity: This bit is the parity of all bytes read from the 71M6545/H in the previous command. Does not include the <i>SPI_STAT</i> byte.</p> <p>Bit 5 - Write data parity: This bit is the overall parity of the bytes written to the 71M6545/H in the previous command. It includes CMD and ADDR bytes.</p> <p>Bit 4:2 - Bottom 3 bits of the byte count. Does not include ADDR and CMD bytes. One, two, and three byte instructions return 111.</p> <p>Bit 1 - SPI FLASH mode: This bit is zero when the TEST pin is zero.</p> <p>Bit 0 - SPI FLASH mode ready: Used in SPI FLASH mode. Indicates that the flash is ready to receive another write instruction.</p>								
<i>STEMP</i> [10:3] <i>STEMP</i> [2:0]	2881[7:0] 2882[7:5]	– –	– –	R R	The result of the temperature measurement.								
<i>SUM_SAMPS</i> [12:8] <i>SUM_SAMPS</i> [7:0]	2107[4:0] 2108[7:0]	0	0	R/W	The number of multiplexer cycles (frames) per XFER_BUSY interrupt. Maximum value is 8191 cycles.								
<i>TBYTE_BUSY</i>	28A0[3]	0	0	R	Indicates that hardware is still writing the 0x28A0 byte. Additional writes to this byte are locked out while it is one. Write duration could be as long as 6 ms.								
<i>TEMP_22</i> [10:8] <i>TEMP_22</i> [7:0]	230A[2:0] 230B[7:0]	0	–	R	Storage location for <i>STEMP</i> [10:0] at 22C. <i>STEMP</i> [10:0] is an 11 bit word.								
<i>TEMP_BAT</i>	28A0[4]	0	–	R/W	Causes VBAT_RTC to be measured whenever a temperature measurement is performed.								
<i>Reserved</i>	28A0[7]	0	–	R/W	Reserved. Must always be zero.								
<i>TEMP_PER</i> [2:0]	28A0[2:0]	0	–	R/W	<p>Sets the period between temperature measurements. Automatic measurements can be enabled in any mode (MSN or SLP). <i>TEMP_PER</i> = 0 disables automatic temperature updates, in which case <i>TEMP_START</i> may be used by the MPU to initiate a one-shot temperature measurement.</p> <table border="1"> <thead> <tr> <th><i>TEMP_PER</i></th> <th>Time (seconds)</th> </tr> </thead> <tbody> <tr> <td>0</td> <td>No temperature updates</td> </tr> <tr> <td>1-6</td> <td>$2^{(3 \cdot \text{TEMP_PER})}$</td> </tr> <tr> <td>7</td> <td>Continuous updates</td> </tr> </tbody> </table>	<i>TEMP_PER</i>	Time (seconds)	0	No temperature updates	1-6	$2^{(3 \cdot \text{TEMP_PER})}$	7	Continuous updates
<i>TEMP_PER</i>	Time (seconds)												
0	No temperature updates												
1-6	$2^{(3 \cdot \text{TEMP_PER})}$												
7	Continuous updates												
<i>TEMP_PWR</i>	28A0[6]	0	–	R/W	<p>Selects the power source for the temp sensor: 1 = V3P3D, 0 = VBAT_RTC.</p> <p>This bit is ignored in SLP mode, where the temp sensor is always powered by VBAT_RTC.</p>								

Name	Location	Rst	Wk	Dir	Description												
<i>TEMP_START</i>	28B4[6]	0	0	R/W	When <i>TEMP_PER</i> = 0 automatic temperature measurements are disabled, and <i>TEMP_START</i> may be set by the MPU to initiate a one-shot temperature measurement. <i>TEMP_START</i> is ignored in SLP mode. Hardware clears <i>TEMP_START</i> when the temperature measurement is complete.												
<i>TMUX[5:0]</i>	2502[5:0]	–	–	R/W	Selects one of 32 signals for TMUXOUT. See 2.5.14 for details.												
<i>TMUX2[4:0]</i>	2503[4:0]	–	–	R/W	Selects one of 32 signals for TMUX2OUT. See 2.5.14 for details.												
<i>TMUXR2[2:0]</i> <i>TMUXR4[2:0]</i> <i>TMUXR6[2:0]</i>	270A[2:0] 270A[6:4] 2709[2:0]	000	000	R/W	The TMUX setting for the remote isolated sensors (71M6xx3).												
<i>VERSION[7:0]</i>	2706[7:0]	–	–	R	The silicon version index. This word may be read by firmware to determine the silicon version. <table border="1"> <thead> <tr> <th><i>VERSION[7:0]</i></th> <th>Silicon Version</th> </tr> </thead> <tbody> <tr> <td>0001 0001</td> <td>A01</td> </tr> <tr> <td>0001 0011</td> <td>A03</td> </tr> <tr> <td>0001 0011</td> <td>B01</td> </tr> </tbody> </table>	<i>VERSION[7:0]</i>	Silicon Version	0001 0001	A01	0001 0011	A03	0001 0011	B01				
<i>VERSION[7:0]</i>	Silicon Version																
0001 0001	A01																
0001 0011	A03																
0001 0011	B01																
<i>VREF_CAL</i>	2704[7]	0	0	R/W	Brings the ADC reference voltage out to the VREF pin. This feature is disabled when <i>VREF_DIS</i> =1.												
<i>VREF_DIS</i>	2704[6]	0	1	R/W	Disables the internal ADC voltage reference.												
<i>VSTAT[2:0]</i>	SFR F9[2:0]	–	–	R	This word describes the source of power and the status of the VDD. <table border="1"> <thead> <tr> <th><i>VSTAT[2:0]</i></th> <th>Description</th> </tr> </thead> <tbody> <tr> <td>000</td> <td>System Power OK. V3P3A>3.0v. Analog modules are functional and accurate. [V3AOK,V3OK]=11</td> </tr> <tr> <td>001</td> <td>System Power Low. 2.8v<V3P3A<3.0v. Analog modules not accurate. [V3AOK,V3OK]=01</td> </tr> <tr> <td>010</td> <td>VDD OK. VDD>2.25v. Full digital functionality. [V3AOK,V3OK]=00, [VDDOK,VDDgt2]=11</td> </tr> <tr> <td>011</td> <td>VDD>2.0. Flash writes are inhibited. If the TRIMVDD[5] fuse is blown, <i>PLL_FAST</i> is cleared. [V3AOK,V3OK]=00, [VDDOK,VDDgt2]=01</td> </tr> <tr> <td>101</td> <td>VDD<2.0. When <i>VSTAT</i>=101, processor is nearly out of voltage. Processor failure is imminent. [V3AOK,V3OK]=00, [VDDOK,VDDgt2]=00</td> </tr> </tbody> </table>	<i>VSTAT[2:0]</i>	Description	000	System Power OK. V3P3A>3.0v. Analog modules are functional and accurate. [V3AOK,V3OK]=11	001	System Power Low. 2.8v<V3P3A<3.0v. Analog modules not accurate. [V3AOK,V3OK]=01	010	VDD OK. VDD>2.25v. Full digital functionality. [V3AOK,V3OK]=00, [VDDOK,VDDgt2]=11	011	VDD>2.0. Flash writes are inhibited. If the TRIMVDD[5] fuse is blown, <i>PLL_FAST</i> is cleared. [V3AOK,V3OK]=00, [VDDOK,VDDgt2]=01	101	VDD<2.0. When <i>VSTAT</i> =101, processor is nearly out of voltage. Processor failure is imminent. [V3AOK,V3OK]=00, [VDDOK,VDDgt2]=00
<i>VSTAT[2:0]</i>	Description																
000	System Power OK. V3P3A>3.0v. Analog modules are functional and accurate. [V3AOK,V3OK]=11																
001	System Power Low. 2.8v<V3P3A<3.0v. Analog modules not accurate. [V3AOK,V3OK]=01																
010	VDD OK. VDD>2.25v. Full digital functionality. [V3AOK,V3OK]=00, [VDDOK,VDDgt2]=11																
011	VDD>2.0. Flash writes are inhibited. If the TRIMVDD[5] fuse is blown, <i>PLL_FAST</i> is cleared. [V3AOK,V3OK]=00, [VDDOK,VDDgt2]=01																
101	VDD<2.0. When <i>VSTAT</i> =101, processor is nearly out of voltage. Processor failure is imminent. [V3AOK,V3OK]=00, [VDDOK,VDDgt2]=00																
<i>WAKE_TMR</i>	2880[7:0]	0	–	R/W	Timer duration is <i>WAKE_TMR</i> +1 seconds.												
<i>WD_RST</i>	28B4[7]	0	0	W	Reset the WD timer. The WD is reset when a 1 is written to this bit. Writing a one clears and restarts the watch dog timer.												

5.3 Reading the Info Page (71M6545H only)

High precision trim fuse values provided in the 71M6545H device cannot be directly accessed through the I/O RAM space. These trim fuses reside in a special area termed the "Info Page". The MPU gains access to the Info Page by setting the *INFO_PG* (I/O RAM 0x270B[0]) control bit. Once the *INFO_PG* bit is set, Info Page contents are accessible in program memory space based at the address specified by the contents of *CE_LCTN*[5:0] (I/O RAM 0x2109[5:0]). *CE_LCTN*[5:0] specifies a base address at a 1KB address boundary. Thus, the base address for the Info Page is at 1024**CE_LCTN*[5:0]. Table 62 provides a list of the available 71M6545H trim fuses and their corresponding offsets relative to the Info Page base address. After reading the desired Info Page information, the MPU must reset the *INFO_PG* bit.

Table 62. Info Page Trim Fuses

Trim Fuse	Object Size	Address Offset	Comments
<i>TEMP_85</i> [10:8] <i>TEMP_85</i> [7:0] (11-bits)	8-bits 8-bits	0x90 0x91	<i>TEMP_85</i> [10:0] holds the <i>STEMP</i> [10:0] reading at 85°C. 2's complement format
<i>TRIMBGB</i> [15:8] <i>TRIMBGB</i> [7:0] (16-bits)	8-bits 8-bits	0x92 0x93	<i>TRIMBGB</i> [15:0] holds the deviation of VREF from its ideal value (1.195V) at 85°C. LSB = 0.1 mV 2's complement format
<i>TRIMBGD</i> [7:0] (8-bits)	8-bits	0x94	<i>TRIMBGD</i> [7:0] holds the deviation of VREF from its ideal value (1.195V) at 22°C. LSB = 0.1 mV 2's complement format

Figure 33. Trim Fuse Bit Mapping

Offset	Name	Bit 7	Bit 6	Bit 5	Bit 4	Bit 3	Bit 2	Bit 1	Bit 0
0x90	<i>TEMP_85</i> [10:0]								TEMP_85[10:8]
0x91									TEMP_85[7:0]
0x92	<i>TRIMBGB</i> [15:0]								TRIMBGB[15:8]
0x93									TRIMBGB[7:0]
0x94	<i>TRIMBGD</i> [7:0]								TRIMBGD[7:0]

The code below provides an example for reading Info Page fuse trims. In this code example, the address, "px" is a pointer to the MPU's code space. In assembly language, the Info Page data objects, which are read-only, must be accessed with the MOVC 8051 instruction.

In C, Info Page trim fuses must be fetched with a pointer of the correct width, depending whether an 8-bit or a 16-bit data object is to be fetched. The case statements in the code example below perform casts to obtain a pointer of the correct size for each object, as needed.

In assembly language, the MPU has to form 11-bit or 16-bit values from two separate 8-bit fetches, depending on the object being fetched.

The byte values containing less than 8 valid bits are LSB justified. For example Info Page offset 0x90 is an 8-bit object, whose three LSBs are bits [10:8] of the complete *TEMP_85*[10:0] 11-bit object. The Info Page data objects are 2's complement format and should be sign extended when read into a 16-bit data type (see case `_TEMP85` in the code example).

```
#if HIGH_PRECISION_METER
int16_t read_trim (enum eTRIMSEL select) {
    uint8r_t *px;
    int16_t x;
    px = ((uint16_t)select) + ((uint8r_t *) (CE3 << 10));
    switch (select)
    {
        default:
        case _TRIMBGD:
            INFO_PG = 1;
            x = *px;
            INFO_PG = 0;
            break;
        case _TRIMBGB:
            INFO_PG = 1;
            x = *(uint16r_t*)px;
            INFO_PG = 0;
            break;
        case _TEMP85:
            INFO_PG = 1;
            x = *(uint16r_t*)px;
            INFO_PG = 0;
            if (x & 0x800)
                x |= 0xF800;
            break;
    }
    return (x);
}
#endif // #if HIGH_PRECISION_METER
```

5.4 CE Interface Description

5.4.1 CE Program

The CE performs the precision computations necessary to accurately measure power. These computations include offset cancellation, phase compensation, product smoothing, product summation, frequency detection, VAR calculation, sag detection and voltage phase measurement. All data computed by the CE is dependent on the selected meter equation as given by *EQU[2:0]* (I/O RAM *0x2106[7:5]*).

The standard CE program is supplied by Silergy as a data image that can be merged with the MPU operational code for meter applications. Typically, this CE program covers most applications and does not need to be modified. Other variations of CE code may be available from Silergy. The description in this section applies to CE code revision CE43A01A.

5.4.2 CE Data Format

All CE words are 4 bytes. Unless specified otherwise, they are in 32-bit two's complement format (-1 = 0xFFFFFFFF). Calibration parameters are defined in flash memory (or external EEPROM) and must be copied to CE data memory by the MPU before enabling the CE. Internal variables are used in internal CE calculations. Input variables allow the MPU to control the behavior of the CE code. Output variables are outputs of the CE calculations. The corresponding MPU address for the most significant byte is given by $0x0000 + 4 \times \text{CE_address}$ and by $0x0003 + 4 \times \text{CE_address}$ for the least significant byte.

5.4.3 Constants

Constants used in the CE Data Memory tables are:

Sampling Frequency: $F_s = 32768 \text{ Hz}/15 = 2184.53 \text{ Hz}$.

F_0 is the fundamental frequency of the mains phases.

IMAX is the external rms current corresponding to 250 mV pk at each IADC input.

VMAX is the external rms voltage corresponding to 250 mV pk at each VADC input.

NACC, the accumulation count for energy measurements is *SUM_SAMPS[12:0]* (I/O RAM *0x2107[4:0]*, *0x2108[7:0]*). This value also resides in *SUM_PRE* (CE RAM *0x23*) where it is used for phase angle measurement.

The duration of the accumulation interval for energy measurements is $\text{SUM_SAMPS}[12:0] / F_s$.

X is a gain constant of the pulse generators. Its value is determined by *PULSE_FAST* and *PULSE_SLOW* (see Table 68).

Voltage LSB = $V_{\text{MAX}} * 7.879810^{-9} \text{ V}$.

$V_{\text{MAX}} = 600 \text{ V}$, $I_{\text{MAX}} = 208 \text{ A}$, and $kH = 3.2 \text{ Wh/pulse}$ are assumed as default settings.

The system constants IMAX and VMAX are used by the MPU to convert internal digital quantities (as used by the CE) to external, i.e. metering quantities. Their values are determined by the scaling of the voltage and current sensors used in an actual meter. The LSB values used in this document relate digital quantities at the CE or MPU interface to external meter input quantities. For example, if a SAG threshold of 80 V peak is desired at the meter input, the digital value that should be programmed into *SAG_THR* (CE RAM *0x24*) would be $80 \text{ V}/\text{SAG_THR}_{\text{LSB}}$, where *SAG_THR*_{LSB} is the LSB value in the description of *SAG_THR* (Table 69).

The parameters *EQU[2:0]*, *CE_E*, and *SUM_SAMPS[12:0]*, essential to the function of the CE are stored in I/O RAM (see 5.2 for details).

5.4.4 Environment

Before starting the CE using the *CE_E* bit (*I/O RAM 0x2106[0]*), the MPU has to establish the proper environment for the CE by implementing the following steps:

Locate the CE code in Flash memory using *CE_LCTN[5:0]* (*I/O RAM 0x2109[5:0]*)

Load the CE data into RAM.

Establish the equation to be applied in *EQU[2:0]* (*I/O RAM 0x2106[7:5]*).

Establish the accumulation period and number of samples in *SUM_SAMPS[12:0]* (*I/O RAM 0x2107[4:0], 0x2108[7:0]*).

Establish the number of cycles per ADC multiplexer frame (*MUX_DIV[3:0]* (*I/O RAM 0x2100[7:4]*)).

Apply proper values to *MUXn_SEL*, as well as proper selections for *DIFFn_E* (*I/O RAM 0x210C[]*) and *RMTn_E* (*I/O RAM 0x2709[]*) in order to configure the analog inputs.

Initialize any MPU interrupts, such as *CE_BUSY*, *XFER_BUSY*, or the power-failure detection interrupt.

When different CE codes are used, a different set of environment parameters need to be established. The exact values for these parameters are listed in the Application Notes and other documentation which accompanies the CE code.



Operating CE codes with environment parameters deviating from the values specified by Silergy leads to unpredictable results.

Typically, there are fifteen 32768 Hz cycles per ADC multiplexer frame (see 2.2.2). This means that the product of the number of cycles per frame and the number of conversions per frame must be 14 (allowing for one settling cycle). The default configuration is *FIR_LEN* = 01, *I/O RAM 0x210C[1]* (two cycles per conversion) and *MUX_DIV[3:0]* = 7 (7 conversions per multiplexer cycle).

Sample configurations can be copied from Demo Code provided by Silergy with the Demo Kits.

5.4.5 CE Calculations

Referring to Table 63, The MPU selects the desired equation by writing the *EQU[2:0]* (*I/O RAM 0x2106[7:5]*).

Table 63: CE *EQU[2:0]* Equations and Element Input Mapping

<i>EQU</i> [2:0]*	Watt & VAR Formula (<i>WSUM/VARSUM</i>)	<i>W0SUM</i> / <i>VAR0SUM</i>	<i>W1SUM</i> / <i>VAR1SUM</i>	<i>W2SUM</i> / <i>VAR2SUM</i>	<i>I0SQ</i> <i>SUM</i>	<i>I1SQ</i> <i>SUM</i>	<i>I2SQ</i> <i>SUM</i>
2	$VA \cdot IA + VB \cdot IB$ (2-element, 3-W, 3 Delta)	$VA \cdot IA$	$VB \cdot IB$	N/A	IA	IB	–
3	$VA \cdot (IA - IB) / 2 + VC \cdot IC$ (2 element, 4W 3 Delta)	$VA \cdot (IA - IB) / 2$	–	$VC \cdot IC$	IA-IB	IB	IC
4	$VA \cdot (IA - IB) / 2 + VB \cdot (IC - IB) / 2$ (2 element, 4W 3 Wye)	$VA \cdot (IA - IB) / 2$	$VB \cdot (IC - IB) / 2$	–	IA-IB	IC-IB	IC
5	$VA \cdot IA + VB \cdot IB + VC \cdot IC$ (3 element, 4W 3 Wye)	$VA \cdot IA$	$VB \cdot IB$	$VC \cdot IC$	IA	IB	IC

Note:

* Only *EQU[2:0]* = 5 is supported by the currently available CE code versions for the 71M6545/H. Contact Silergy for CE codes that support equations 2, 3 and 4.

5.4.6 CE Front End Data (Raw Data)

Access to the raw data provided by the AFE is possible by reading CE RAM addresses 0 through A, as shown in Table 64. In the expression $MUXn_SEL[3:0] = x$, 'n' refers to the multiplexer frame time slot number and 'x' refers to the desired ADC input number or ADC handle (i.e., IADC0 to VADC10, or simply 0 to 10 decimal).

The 71M6545/H can support up to eleven sensor inputs, when all the current sensors are configured as single-ended inputs. If all the current sensor inputs are configured as differential (recommended for best performance), the number of input sensor channels is reduced to seven (i.e., IADC0-1, IADC2-3, IADC4-5, IADC6-7, VADC8, VADC9 and VADC10). The $MUXn_SEL[3:0]$ column in Table 64 shows the $MUXn_SEL$ handles for the various sensor input pins. For example, if differential mode is enabled via control bit $DIFF0_E = 1$ (I/O RAM $0x210C[4]$), then the IADC0-IADC1 input pins are combined together to form a single differential input and the corresponding $MUXn_SEL$ handle is 0 (i.e., handle 1 is then unused). Similarly, the CE RAM location column provides the CE RAM address where the corresponding sample data is stored. Continuing with the same example, if $DIFF0_E = 1$, the corresponding CE RAM location where the samples for the IADC0-IADC1 differential input are stored is CE RAM 0.

The IADC2-3, IADC4-5 and IADC6-7 inputs can be configured as direct-connected sensors (i.e., directly connected to the 71M6545/H) or as remote sensors (i.e., using a 71M6xx3 Isolated Sensor). For example, if the IADC2-3 remote sensor is disabled by $RMT2_E = 0$ (I/O RAM $0x2007[3]$) and differential mode is enabled by $DIFF2_E = 1$ (I/O RAM $0x210C[4]$), then IADC2-IADC3 form a differential input with a $MUXn_SEL$ handle of 2 (i.e., handle 3 is then unused), and the corresponding samples are stored in CE RAM location 2. If the remote sensor enable bit $RMT2_E = 1$, $DIFF2_E = x$ (don't care), then the $MUXn_SEL$ handle is not required (i.e., the sensor is not connected to the 71M6545/H multiplexer, so $MUXn_SEL$ does not apply), and the samples corresponding to this remote differential IADC2-IADC3 input are stored in CE RAM location 2 directly by the digital isolation interface (see Figure 2).

The voltage sensor inputs (VADC8, VADC9 and VADC10) are always single-ended inputs and cannot be configured as remotes, so they do not have any associated configuration bits. VADC8 (VA) has a $MUXn_SEL$ handle value of 8, and its samples are stored in CE RAM location 8. VADC9 (VB) has a $MUXn_SEL$ handle value of 9 and its samples are stored in CE RAM location 9. VADC10 (VC) has a $MUXn_SEL$ handle value of 10 and its samples are stored in CE RAM location 10.

Table 64: CE Raw Data Access Locations

Pin	MUXn_SEL Handle				CE RAM Location			
	DIFF0_E				DIFF0_E			
	0	1			0	1		
IADC0	0	0			0	0		
IADC1	1				1			
	RMT2_E, DIFF2_E				RMT2_E, DIFF2_E			
	0,0	0,1	1,0	1,1	0,0	0,1	1,0	1,1
IADC2	2	2	-	-	2	2	2*	2*
IADC3	3		3					
	RMT4_E, DIFF4_E				RMT4_E, DIFF4_E			
	0,0	0,1	1,0	1,1	0,0	0,1	1,0	1,1
IADC4	4	4	-	-	4	4	4*	4*
IADC5	5		5					
	RMT6_E, DIFF6_E				RMT6_E, DIFF6_E			
	0,0	0,1	1,0	1,1	0,0	0,1	1,0	1,1
IADC6	6	6	-	-	6	6	6*	6*
IADC7	7		7					
	There are no configuration bits for VADC8, 9, 10							
VADC8 (VA)	8				8			
VADC9 (VB)	9				9			
VADC10 (VC)	10				10			

*Remote interface data

5.4.7 CE Status and Control

The CE Status Word is useful for generating early warnings to the MPU (Table 65). It contains sag warnings for phase A, B, and C, as well as *F0*, the derived clock operating at the fundamental input frequency. The MPU can read the CE status word at every CE_BUSY interrupt. Since the CE_BUSY interrupt occurs at the sample rate (i.e., 2520.6 Hz for *MUX_DIV[3:0]=6* or 2184.5 Hz for *MUX_DIV[3:0]=7*), it is desirable to minimize the computation required in the interrupt handler of the MPU.

Table 65: CESTATUS Register

CE Address	Name	Description
0x80	<i>CESTATUS</i>	See description of <i>CESTATUS</i> bits in Table 66.

CESTATUS provides information about the status of voltage and input AC signal frequency, which are useful for generating an early power fail warning to initiate necessary data storage. *CESTATUS* represents the status flags for the preceding CE code pass (CE_BUSY interrupt). The significance of the bits in *CESTATUS* is shown in Table 66.

Table 66: CESTATUS Bit Definitions

<i>CESTATUS</i> bit	Name	Description
31:4	Not Used	These unused bits are always zero.
3	<i>F0</i>	<i>F0</i> is a square wave at the exact fundamental input frequency.
2	<i>SAG_C</i>	Normally zero. Becomes one when VADC10 (VC) remains below <i>SAG_THR</i> (CE RAM 0x24) for <i>SAG_CNT</i> samples. Does not return to zero until VADC10 (VC) rises above <i>SAG_THR</i> .
1	<i>SAG_B</i>	Normally zero. Becomes one when VADC9 (VB) remains below <i>SAG_THR</i> for <i>SAG_CNT</i> samples. Does not return to zero until VADC9 (VB) rises above <i>SAG_THR</i> .
0	<i>SAG_A</i>	Normally zero. Becomes one when VADC8 (VA) remains below <i>SAG_THR</i> for <i>SAG_CNT</i> samples. Does not return to zero until VADC8 (VA) rises above <i>SAG_THR</i> .

The CE is initialized by the MPU using *CECONFIG* (Table 67). This register contains in packed form *SAG_CNT*, *FREQSEL0*, *FREQSEL1*, *EXT_PULSE*, *PULSE_SLOW*, and *PULSE_FAST*. The *CECONFIG* bit definitions are given in Table 68.

Table 67: CECONFIG Register

CE Address	Name	Data	Description
0x20	<i>CECONFIG</i>	0x0030DA20	See description of the <i>CECONFIG</i> bits in Table 68.

The *EXT_TEMP* bit enables temperature compensation by the MPU, when set to 1. When 0, internal (CE) temperature compensation is enabled.

The CE pulse generator can be controlled by either the MPU (external) or CE (internal) variables. Control is by the MPU if *EXT_PULSE* = 1. In this case, the MPU controls the pulse rate by placing values into *APULSEW* and *APULSER* (CE RAM 0x44 and 0x48). By setting *EXT_PULSE* = 0, the CE controls the pulse rate based on *WSUM_X* (CE RAM 0x84) and *VARSUM_X* (CE RAM 0x88).



The 71M6545/H Demo Code creep function halts both internal and external pulse generation.

Table 68: CECONFIG Bit Definitions (CE RAM 0x20)

CECONFIG bit	Name	Default	Description																														
23	<i>Reserved</i>	0	Reserved (can be used by the MPU to indicate that the 71M6x03 is being used; CE does not use this).																														
22	<i>EXT_TEMP</i>	0	When 1, the MPU controls temperature compensation via the <i>GAIN_ADJn</i> (CE RAM 0x40-0x42), when 0, the CE is in control.																														
21	<i>EDGE_INT</i>	1	When 1, XPULSE produces a pulse for each zero-crossing of the mains phase selected by <i>FREQSEL[1:0]</i> , which can be used to interrupt the MPU.																														
20	<i>SAG_INT</i>	1	When 1, activates the YPULSE/DIO7 output when a sag is detected on the phase selected with <i>FREQSEL[1:0]</i> .																														
19:8	<i>SAG_CNT</i>	218 (0xDA)	The number of consecutive voltage samples below <i>SAG_THR</i> (CE RAM 0x24) before a sag alarm is declared. The default value is equivalent to 100 ms.																														
7:6	<i>FREQSEL[1:0]</i>	0	<p><i>FREQSEL[1:0]</i> selects the phase to be used for the frequency monitor, sag detection, the phase-to-phase lag calculation and for the zero crossing counter (<i>MAINEDGE_X</i>, CE RAM 0x83).</p> <table border="1"> <thead> <tr> <th colspan="2"><i>FREQ SEL[1:0]</i></th> <th>Phase Selected</th> <th colspan="2">Phases Selected</th> </tr> <tr> <th></th> <th></th> <th></th> <th><i>PH_AtoB_X</i></th> <th><i>PH_AtoC_X</i></th> </tr> </thead> <tbody> <tr> <td>0</td> <td>0</td> <td>A</td> <td>A-B</td> <td>A-C</td> </tr> <tr> <td>0</td> <td>1</td> <td>B</td> <td>B-C</td> <td>B-A</td> </tr> <tr> <td>1</td> <td>0</td> <td>C</td> <td>C-A</td> <td>C-B</td> </tr> <tr> <td>1</td> <td>1</td> <td colspan="3">Not allowed</td> </tr> </tbody> </table>	<i>FREQ SEL[1:0]</i>		Phase Selected	Phases Selected					<i>PH_AtoB_X</i>	<i>PH_AtoC_X</i>	0	0	A	A-B	A-C	0	1	B	B-C	B-A	1	0	C	C-A	C-B	1	1	Not allowed		
<i>FREQ SEL[1:0]</i>		Phase Selected	Phases Selected																														
			<i>PH_AtoB_X</i>	<i>PH_AtoC_X</i>																													
0	0	A	A-B	A-C																													
0	1	B	B-C	B-A																													
1	0	C	C-A	C-B																													
1	1	Not allowed																															
5	<i>EXT_PULSE</i>	1	When zero, causes the pulse generators to respond to internal data. <i>WPULSE</i> = <i>WSUM_X</i> (CE RAM 0x84), <i>VPULSE</i> = <i>VARSUM_X</i> (CE RAM 0x88.) Otherwise, the generators respond to values the MPU places in <i>APULSEW</i> and <i>APULSER</i> (CE RAM 0x44 and 0x48)																														
4:2	<i>Reserved</i>	0	Reserved.																														
1	<i>PULSE_FAST</i>	0	When <i>PULSE_FAST</i> = 1, the pulse generator input is increased 16x. When <i>PULSE_SLOW</i> = 1, the pulse generator input is reduced by a factor of 64. These two parameters control the pulse gain factor X (see table below). Allowed values are either 1 or 0. Default is 0 for both (X = 6).																														
0	<i>PULSE_SLOW</i>	0	<table border="1"> <thead> <tr> <th><i>PULSE_FAST</i></th> <th><i>PULSE_SLOW</i></th> <th>X</th> </tr> </thead> <tbody> <tr> <td>0</td> <td>0</td> <td>$1.5 * 2^2 = 6$</td> </tr> <tr> <td>0</td> <td>1</td> <td>$1.5 * 2^{-4} = 0.09375$</td> </tr> <tr> <td>1</td> <td>0</td> <td>$1.5 * 2^6 = 96$</td> </tr> <tr> <td>1</td> <td>1</td> <td>Do not use</td> </tr> </tbody> </table>	<i>PULSE_FAST</i>	<i>PULSE_SLOW</i>	X	0	0	$1.5 * 2^2 = 6$	0	1	$1.5 * 2^{-4} = 0.09375$	1	0	$1.5 * 2^6 = 96$	1	1	Do not use															
<i>PULSE_FAST</i>	<i>PULSE_SLOW</i>	X																															
0	0	$1.5 * 2^2 = 6$																															
0	1	$1.5 * 2^{-4} = 0.09375$																															
1	0	$1.5 * 2^6 = 96$																															
1	1	Do not use																															

The *FREQSEL[1:0]* field in *CECONFIG* (CE RAM 0x20[7:6]) selects the phase that is utilized to generate a sag interrupt. Thus, a *SAG_INT* event occurs when the selected phase has satisfied the sag event criteria as set by the *SAG_THR* (CE RAM 0x24) register and the *SAG_CNT* field in *CECONFIG* (CE RAM 0x20[19:8]). When the *SAG_INT* bit (CE RAM 0x20[20]) is set to 1, a sag event generates a transition on the YPULSE output. After a sag interrupt, the MPU should change the *FREQSEL[1:0]* setting to select the other phase, if it is powered. Even though a sag interrupt is only generated on the selected phase, all three phases are simultaneously checked for sag. The presence of power on a given phase can be sensed by directly checking the *SAG_A*, *SAG_B* and *SAG_C* bits in *CESTATUS* (CE RAM 0x80[0:1]).

The *EXT_TEMP* bit enables temperature compensation by the MPU, when set to 1. When 0, internal (CE) temperature compensation is enabled.

The CE pulse generator can be controlled by either the MPU (external) or CE (internal) variables. Control is by the MPU if the *EXT_PULSE* bit = 1 (*CE RAM 0x20[5]*). In this case, the MPU controls the pulse rate (external pulse generation) by placing values into *APULSEW* and *APULSER* (*CE RAM 0x45 and 0x49*). By setting *EXT_PULSE* = 0, the CE controls the pulse rate based on *WSUM_X* (*CE RAM 0x84*) and *VARSUM_X* (*CE RAM 0x88*).

Table 69: Sag Threshold, Phase Measurement, and Gain Adjust Control

CE Address	Name	Default	Description
0x24	<i>SAG_THR</i>	2.39*10 ⁷	The voltage threshold for sag warnings. The default value is equivalent to 80 V RMS if VMAX = 600 V. $SAG_THR = \frac{\bar{2}}{7.8798 \cdot 10^{-9}}$
0x40	<i>GAIN_ADJ0</i>	16384	The assignments of these gain adjustments depends on the meter design. See 4.5.5 Temperature Compensation for VREF and Shunt Sensors on page 74 or 4.5.6 Temperature Compensation of VREF and Current Transformers on page 76. The default value of 16384 corresponds to unity gain.
0x41	<i>GAIN_ADJ1</i>	16384	
0x42	<i>GAIN_ADJ2</i>	16384	
0x43	<i>GAIN_ADJ3</i>	16384	
0x44	<i>GAIN_ADJ4</i>	16384	

5.4.8 CE Transfer Variables

When the MPU receives the XFER_BUSY interrupt, it knows that fresh data is available in the transfer variables. CE transfer variables are modified during the CE code pass that ends with an XFER_BUSY interrupt. They remain constant throughout each accumulation interval. In this data sheet, the names of CE transfer variables always end with *_X*. The transfer variables can be categorized as:

- Fundamental energy measurement variables
- Instantaneous (RMS) values
- Other measurement parameters

Fundamental Energy Measurement Variables

[Table 70](#) describes each transfer variable for fundamental energy measurement. All variables are signed 32-bit integers. Accumulated variables such as *WSUM* are internally scaled so they have at least 2x margin before overflow when the integration time is one second. Additionally, the hardware does not permit output values to fold back upon overflow.

Table 70: CE Transfer Variables (with Shunts)

CE Address	Name	Description	Configuration
0x84	<i>WSUM_X</i>	The signed sum: <i>W0SUM_X+W1SUM_X+W2SUM_X</i> .	Figure 27 (page 71)
0x85	<i>W0SUM_X</i>	The sum of Wh samples from each wattmeter element. $LSB_w = 7.7562 \cdot 10^{-13} \text{ VMAX} \cdot \text{IMAX Wh.}$	
0x86	<i>W1SUM_X</i>		
0x87	<i>W2SUM_X</i>		
0x88	<i>VARSUM_X</i>	The signed sum: <i>VAR0SUM_X+VAR1SUM_X+VAR2SUM_X</i> .	
0x89	<i>VAR0SUM_X</i>	The sum of VARh samples from each wattmeter element. $LSB_w = 7.7562 \cdot 10^{-13} \text{ VMAX} \cdot \text{IMAX VARh.}$	
0x8A	<i>VAR1SUM_X</i>		
0x8B	<i>VAR2SUM_X</i>		

Table 71: CE Transfer Variables (with CTs)

CE Address	Name	Description	Configuration
0x84	<i>WSUM_X</i>	The signed sum: $W0SUM_X + W1SUM_X + W2SUM_X$.	Figure 28 (page 72)
0x85	<i>W0SUM_X</i>	The sum of Wh samples from each wattmeter element. $LSB_w = 1.0856 \cdot 10^{-12} \text{ VMAX IMAX Wh}$.	
0x86	<i>W1SUM_X</i>		
0x87	<i>W2SUM_X</i>		
0x88	<i>VARSUM_X</i>	The signed sum: $VAR0SUM_X + VAR1SUM_X + VAR2SUM_X$.	
0x89	<i>VAR0SUM_X</i>	The sum of VARh samples from each wattmeter element. $LSB_w = 1.0856 \cdot 10^{-12} \text{ VMAX IMAX VARh}$.	
0x8A	<i>VAR1SUM_X</i>		
0x8B	<i>VAR2SUM_X</i>		

WSUM_X and *VARSUM_X* are the signed sum of Phase-A, Phase-B and Phase-C Wh or VARh values according to the metering equation specified in the control field *EQU[2:0]* (I/O RAM 0x2106[7:5]).

WnSUM_X is the Wh value accumulated for phase n in the last accumulation interval and can be computed based on the specified LSB value.

For example, with VMAX = 600 V and IMAX = 208 A, the LSB for *WnSUM_X* is 0.135 μ Wh.

5.4.8.1 Instantaneous Energy Measurement Variables

InSQSUM_X and *VnSQSUM* are the squared current and voltage samples acquired during the last accumulation interval. *INSQSUM_X* can be used for computing the neutral current.

Table 72: CE Energy Measurement Variables (with Shunts)

CE Address	Name	Description	Configuration
0x8C	<i>I0SQSUM_X</i>	Neutral Current: $LSB_i = 9.9045 \cdot 10^{-13} \cdot \text{IMAX}^2 \text{ A}^2\text{h}$ (<i>PRE_E</i> =0) $LSB_i = 6.1903125 \cdot 10^{-14} \cdot \text{IMAX}^2 \text{ A}^2\text{h}$ (<i>PRE_E</i> =1)	Figure 27 (page 71)
0x8D	<i>I1SQSUM_X</i>	$LSB_i = 6.3968 \cdot 10^{-13} \cdot (\text{IMAX}^2) \text{ A}^2\text{h}$	
0x8E	<i>I2SQSUM_X</i>		
0x8F	<i>I3SQSUM_X</i>		
0x90	<i>V0SQSUM_X</i>	$LSB_v = 9.4045 \cdot 10^{-13} \cdot \text{VMAX}^2 \text{ V}^2\text{h}$	
0x91	<i>V1SQSUM_X</i>		
0x92	<i>V2SQSUM_X</i>		

Table 73: CE Energy Measurement Variables (with CTs)

CE Address	Name	Description	Configuration
0x8C	<i>I0SQSUM_X</i>	$LSB_i = 1.0856 \cdot 10^{-12} \cdot (\text{IMAX}^2) \text{ A}^2\text{h}$	Figure 28 (page 72)
0x8D	<i>I1SQSUM_X</i>		
0x8E	<i>I2SQSUM_X</i>		
0x8F	<i>I3SQSUM_X</i>		
0x90	<i>V0SQSUM_X</i>	$LSB_v = 1.0856 \cdot 10^{-12} \cdot \text{VMAX}^2 \text{ V}^2\text{h}$	
0x91	<i>V1SQSUM_X</i>		
0x92	<i>V2SQSUM_X</i>		

The RMS values can be computed by the MPU from the squared current and voltage samples as follows:

$$I_{x_{RMS}} = \sqrt{\frac{I_xSQSUM \text{ LSB}_I \cdot 3600 \cdot F_S}{N_{ACC}}} \quad V_{x_{RMS}} = \sqrt{\frac{V_xSQSUM \text{ LSB}_V \cdot 3600 \cdot F_S}{N_{ACC}}}$$

Other transfer variables include those available for frequency and phase measurement, and those reflecting the count of the zero-crossings of the mains voltage and the battery voltage. These transfer variables are listed in [Table 74](#).

MAINEDGE_X reflects the number of half-cycles accounted for in the last accumulated interval for the AC signal of the phase specified in the *FREQSEL[1:0]* field of the *CECONFIG* register (*CE RAM 0x20[7:6]*). *MAINEDGE_X* is useful for implementing a real-time clock based on the input AC signal.

Table 74: Other Transfer Variables

CE Address	Name	Description
0x82	<i>FREQ_X</i>	Fundamental frequency: LSB $\frac{2184Hz}{2^{32}}$ $0.509 \cdot 10^6 \text{ Hz (for CT)}$ LSB $\frac{2520Hz}{2^{32}}$ $0.587 \cdot 10^6 \text{ Hz (for Shunt)}$
0x83	<i>MAINEDGE_X</i>	The number of edge crossings of the selected voltage in the previous accumulation interval. Edge crossings are either direction and are de-bounced.
0x94	<i>PH_AtoB_X</i>	Voltage phase lag. The selection of the reference phase is based on <i>FREQSEL[1:0]</i> in the <i>CECONFIG</i> register: If <i>FREQSEL[1:0]</i> selects phase A: Phase lag from A to B. If <i>FREQSEL[1:0]</i> selects phase B: Phase lag from B to C. If <i>FREQSEL[1:0]</i> selects phase C: Phase lag from C to A. Angle in degrees is (0 to 360): $PH_AtoB_X \cdot 360/N_{ACC} + 2.4 \cdot 15/13$ (for CT) Angle in degrees is (0 to 360): $PH_AtoB_X \cdot 360/N_{ACC} + 2.4$ (for Shunt)
0x95	<i>PH_AtoC_X</i>	If <i>FREQSEL[1:0]</i> selects phase A: Phase lag from A to C. If <i>FREQSEL[1:0]</i> selects phase B: Phase lag from B to A. If <i>FREQSEL[1:0]</i> selects phase C: Phase lag from C to B. Angle in degrees is (0 to 360): $PH_AtoC_X \cdot 360/N_{ACC} + 4.8 \cdot 15/13$ (for CT) Angle in degrees is (0 to 360): $PH_AtoC_X \cdot 360/N_{ACC} + 4.8 \cdot 15/13$ (for Shunt)



Phase angle measurement accuracy can be increased by writing values > 1 into *V_ANG_CNT* (*V_ANG_CNT* indicates how many accumulation periods to sum *PH_AtoB_X* and *PH_AtoC_X* over. The MPU then has to divide by that number. For standard CE codes that support shunts with remotes, *V_ANG_CNT* is at CE address 0x53. For standard CE codes that support shunts with CT, *V_ANG_CNT* is at CE address 0x55. For other than standard CE codes, contact Silergy for information).

5.4.9 Pulse Generation

[Table 75](#) describes the CE pulse generation parameters.

The combination of the *CECONFIG PULSE_SLOW* (*CE RAM 0x20[0]*) and *PULSE_FAST* (*CE RAM 0x20[1]*) bits controls the speed of the pulse rate. The default values of 0 and 0 maintain the original pulse rate given by the Kh equation.

WRATE (*CE RAM 0x21*) controls the number of pulses that are generated per measured Wh and VARh quantities. The lower *WRATE* is the slower the pulse rate for measured energy quantity. The metering constant Kh is derived from *WRATE* as the amount of energy measured for each pulse. That is, if Kh =

1Wh/pulse, a power applied to the meter of 120 V and 30 A results in one pulse per second. If the load is 240 V at 150 A, ten pulses per second are generated.

Control is transferred to the MPU for pulse generation if $EXT_PULSE = 1$ (CE RAM 0x20[5]). In this case, the pulse rate is determined by $APULSEW$ and $APULSER$ (CE RAM 0x44 and 0x48). The MPU has to load the source for pulse generation in $APULSEW$ and $APULSER$ to generate pulses. Irrespective of the EXT_PULSE status, the output pulse rate controlled by $APULSEW$ and $APULSER$ is implemented by the CE only. By setting $EXT_PULSE = 1$, the MPU is providing the source for pulse generation. If EXT_PULSE is 0, $WOSUM_X$ and $VAROSUM_X$ are the default pulse generation sources. In this case, creep cannot be controlled since it is an MPU function.

The maximum pulse rate is $3 \cdot F_s = 7.5$ kHz.

See [2.3.6.2 VPULSE and WPULSE](#) (page 26) for details on how to adjust the timing of the output pulses.

The maximum time jitter is 1/6 of the multiplexer cycle period (nominally 67 μ s) and is independent of the number of pulses measured. Thus, if the pulse generator is monitored for one second, the peak jitter is 67 ppm. After 10 seconds, the peak jitter is 6.7 ppm. The average jitter is always zero. If it is attempted to drive either pulse generator faster than its maximum rate, it simply outputs at its maximum rate without exhibiting any rollover characteristics. The actual pulse rate, using $WSUM$ as an example, is:

$$RATE = \frac{WRATE \cdot WSUM \cdot F_s \cdot X}{2^{46}} Hz,$$

where F_s = sampling frequency (2184.53 Hz), X = Pulse speed factor derived from the CE variables $PULSE_SLOW$ (CE RAM 0x20[0]) and $PULSE_FAST$ (CE RAM 0x20[1]).

Table 75: CE Pulse Generation Parameters

CE Address	Name	Default	Description
0x21	$WRATE$	227	$Kh = VMAX \cdot IMAX \cdot K / (WRATE \cdot N_{ACC} \cdot X)$ Wh/pulse where: K = 76.3594 when used with local sensors (CT or shunt) K = 54.5793 when used with 71M6xx3 remote sensors
0x22	$KVAR$	6444	Scale factor for VAR measurement.
0x23	SUM_PRE	2184	Number of samples per accumulation interval, as specified in $SUM_SAMPS[12:0]$, I/O RAM 0x2107[4:0], 0x2108[7:0] (N_{ACC}).
0x45	$APULSEW$	0	Wh pulse (WPULSE) generator input to be updated by the MPU when using external pulse generation. The output pulse rate is: $APULSEW \cdot F_s \cdot 2^{-32} \cdot WRATE \cdot X \cdot 2^{-14}$. This input is buffered and can be updated by the MPU during a conversion interval. The change takes effect at the beginning of the next interval.
0x46	$WPULSE_CTR$	0	Counter for WPULSE output.
0x47	$WPULSE_FRAC$	0	Unsigned numerator, containing a fraction of a pulse. The value in this register always counts up towards the next pulse.
0x48	$WSUM_ACCUM$	0	Roll-over accumulator for WPULSE.
0x49	$APULSER$	0	VARh (VPULSE) pulse generator input.
0x4A	$VPULSE_CTR$	0	Counter for VPULSE output.
0x4B	$VPULSE_FRAC$	0	Unsigned numerator, containing a fraction of a pulse. The value in this register always counts up towards the next pulse.
0x4C	$VSUM_ACCUM$	0	Roll-over accumulator for VPULSE.

Other CE Parameters

Table 76 shows the QUANT CE parameters used for suppression of noise due to scaling and truncation effects. The equations for calculating the LSB weight of each QUANT parameter are provided at the bottom of Table 76.

Table 76: CE Parameters for Noise Suppression and Code Version

CE Address	Name	Default	Description
0x26	<i>QUANT_IA</i>	0	Compensation factors for truncation and noise in current, real energy and reactive energy for phase A.
0x27	<i>QUANT_WA</i>	0	
0x28	<i>QUANT_VARA</i>	0	
0x2A	<i>QUANT_IB</i>	0	Compensation factors for truncation and noise in current, real energy and reactive energy for phase B.
0x2B	<i>QUANT_WB</i>	0	
0x2C	<i>QUANT_VARB</i>	0	
0x2E	<i>QUANT_IC</i>	0	Compensation factors for truncation and noise in current, real energy and reactive energy for phase C.
0x2F	<i>QUANT_WC</i>	0	
0x30	<i>QUANT_VARC</i>	0	
0x31	<i>QUANT_ID</i>	0	Compensation factors for truncation and noise in current for phase D.
LSB weights for use with the 71M6xx3 isolated sensors: $QUANT_Ix_LSB = 5.20864 \cdot 10^{10} \cdot I_{MAX}^2 (Amps^2)$ $QUANT_Wx_LSB = 8.59147 \cdot 10^{10} \cdot V_{MAX} \cdot I_{MAX} (Watts)$ $QUANT_VARx_LSB = 8.59147 \cdot 10^{10} \cdot V_{MAX} \cdot I_{MAX} (Vars)$			
LSB weights for use with Current Transformers (CTs): $QUANT_Ix_LSB = 5.08656 \cdot 10^{13} \cdot I_{MAX}^2 (Amps^2)$ $QUANT_Wx_LSB = 1.04173 \cdot 10^9 \cdot V_{MAX} \cdot I_{MAX} (Watts)$ $QUANT_VARx_LSB = 1.04173 \cdot 10^9 \cdot V_{MAX} \cdot I_{MAX} (Vars)$			

5.4.10 CE Calibration Parameters

Table 77 lists the parameters that are typically entered to effect calibration of meter accuracy.

Table 77: CE Calibration Parameters

CE Address	Name	Default	Description								
0x10	<i>CAL_IA</i>	16384	These constants control the gain of their respective channels. The nominal value for each parameter is $2^{14} = 16384$. The gain of each channel is directly proportional to its CAL parameter. Thus, if the gain of a channel is 1% low, CAL should be increased by 1%.								
0x11	<i>CAL_VA</i>	16384									
0x13	<i>CAL_IB</i>	16384									
0x14	<i>CAL_VB</i>	16384									
0x16	<i>CAL_IC</i>	16384									
0x17	<i>CAL_VC</i>	16384									
0x19	<i>CAL_ID</i>	16384									
0x12	<i>PHADJ_A</i>	0	These constants control the CT phase compensation. No compensation occurs when $PHADJ_X = 0$. As $PHADJ_X$ is increased, more compensation (lag) is introduced. The range is $2^{15} - 1$. If it is desired to delay the current by the angle θ , the equations are: $PHADJ_X = 2^{20} \frac{0.029615 \tan \theta}{0.1714 - 0.0168 \tan \theta} \text{ at 60Hz}$ $PHADJ_X = 2^{20} \frac{0.0206 \tan \theta}{0.1430 - 0.01226 \tan \theta} \text{ at 50Hz}$								
0x15	<i>PHADJ_B</i>	0									
0x18	<i>PHADJ_C</i>	0									
0x12	<i>DLYADJ_A</i>	0	The shunt delay compensation is obtained using the equation provided below: $DLYADJ_X = \frac{1}{360} \left(\frac{a^2 \cos^2 \frac{2f}{f_s} + 2abc \cos \frac{2f}{f_s} + b^2}{c \sin \frac{2f}{f_s}} \right)^{1/2}$ where: $a = 2A$ $b = A^2 - 1$ $c = 2A^2 - 4A \cos \frac{2f}{f_s} - 2$ The table below provides the value of A for each channel: <table border="1" data-bbox="787 1470 1250 1654" style="margin-left: auto; margin-right: auto;"> <thead> <tr> <th>Channel</th> <th>Value of A (decimal)</th> </tr> </thead> <tbody> <tr> <td><i>DLYADJ_A</i></td> <td>13840</td> </tr> <tr> <td><i>DLYADJ_B</i></td> <td>11693</td> </tr> <tr> <td><i>DLYADJ_C</i></td> <td>9359</td> </tr> </tbody> </table> f is the mains frequency. f _s is the sampling frequency.	Channel	Value of A (decimal)	<i>DLYADJ_A</i>	13840	<i>DLYADJ_B</i>	11693	<i>DLYADJ_C</i>	9359
Channel	Value of A (decimal)										
<i>DLYADJ_A</i>	13840										
<i>DLYADJ_B</i>	11693										
<i>DLYADJ_C</i>	9359										
0x15	<i>DLYADJ_B</i>	0									
0x18	<i>DLYADJ_C</i>	0									
<p>Note: The current sensor inputs are not assigned to the A, B and C phases in a fixed manner. The assignments of phases A, B and C depends on how the IADC0-1, IADC2-3, IADC4-5, IADC6-7 current sensing inputs are connected in the meter design. The CE code must be aware of these connections. See Figure 27 and Figure 28 for typical meter configurations. VADC8, VADC9 and VADC10 are assigned to voltage phases VA, VB and VC in a fixed manner, respectively. The CE addresses listed in this table are assigned to phases A, B, and C as indicated by their names.</p>											

5.4.11 CE Flow Diagrams

Figure 34 through Figure 36 show the data flow through the CE in simplified form. Functions not shown include delay compensation, sample interpolation, scaling and the processing of meter equations.

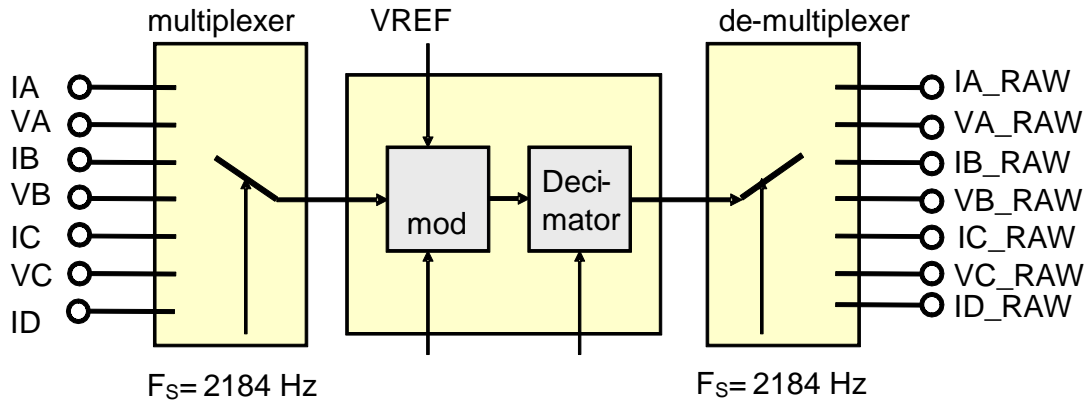

Figure 34: CE Data Flow: Multiplexer and ADC

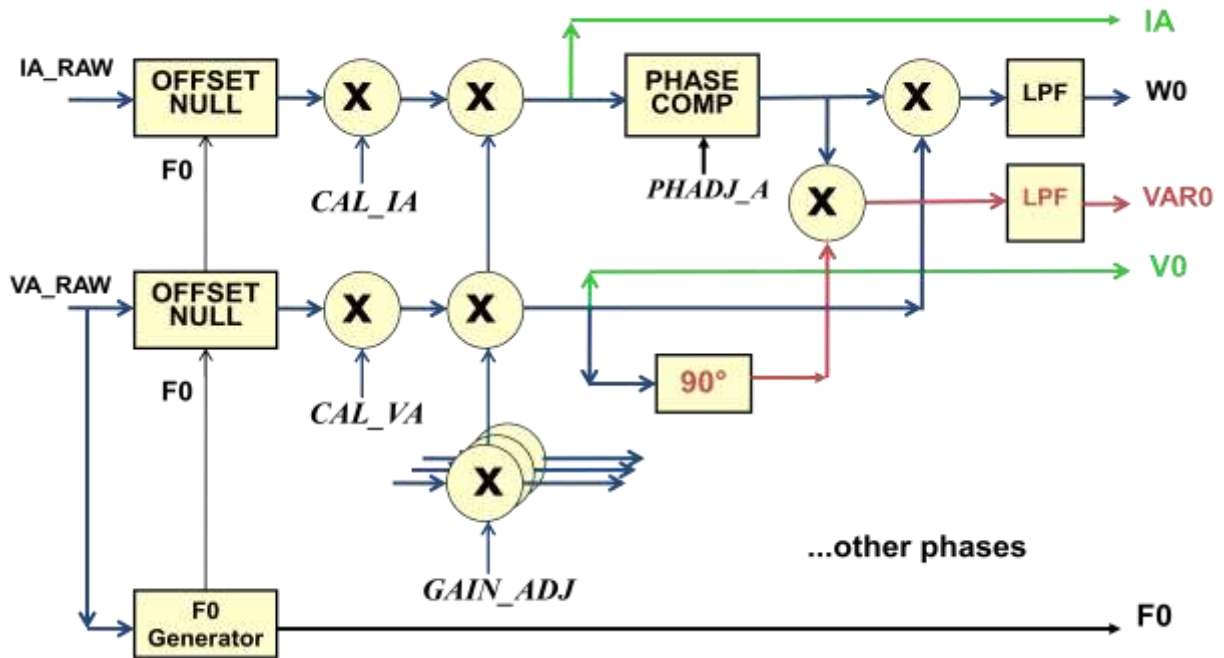

Figure 35: CE Data Flow: Scaling, Gain Control, Intermediate Variables for one Phase

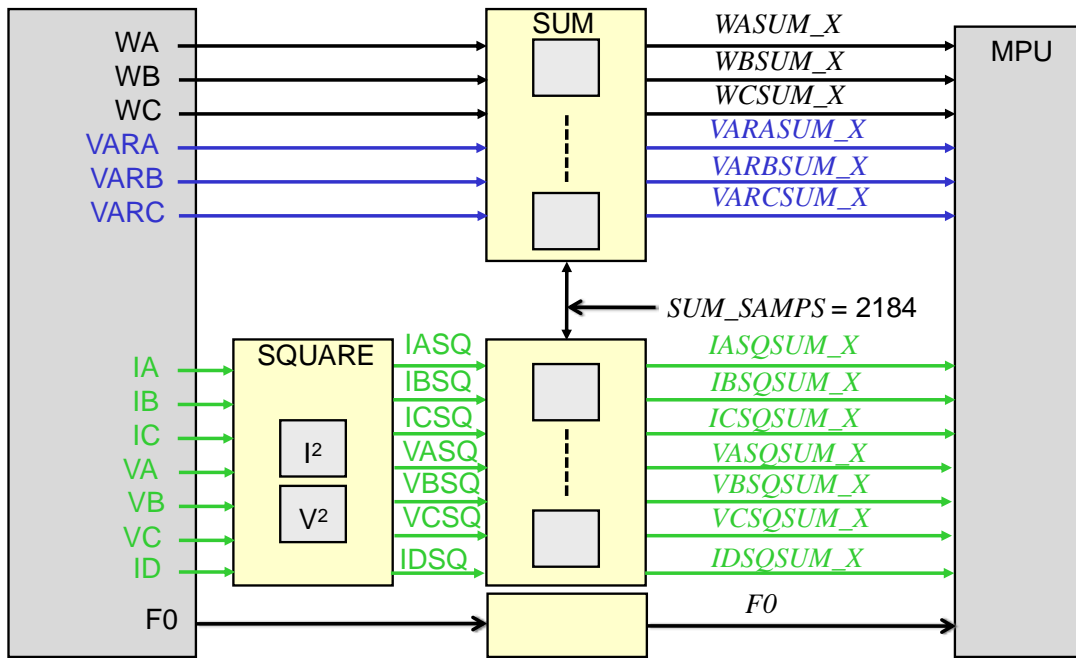

Figure 36: CE Data Flow: Squaring and Summation Stages

6 71M6545/H SPECIFICATIONS

This section provides the electrical specifications for the 71M6545/H. Please refer to the 71M6xxx Data Sheet for the 71M6xx3 electrical specifications, pin-out and package mechanical data.

6.1 Absolute Maximum Ratings

Table 78 shows the absolute maximum ranges for the device. Stresses beyond Absolute Maximum Ratings may cause permanent damage to the device. These are stress ratings only and functional operation at these or any other conditions beyond those indicated under recommended operating conditions (See 6.3) is not implied. Exposure to absolute-maximum-rated conditions for extended periods may affect device reliability. All voltages are with respect to GNDA.

Table 78: Absolute Maximum Ratings

Voltage and Current	
Supplies and Ground Pins	
V3P3SYS, V3P3A	0.5 V to +4.6 V
VBAT_RTC	-0.5 V to +4.6 V
GNDD	-0.1 V to +0.1 V
Analog Output Pins	
VREF	-10 mA to +10 mA, -0.5 V to V3P3A+0.5 V
VDD	-10 mA to +10 mA, -0.5 to +3.0 V
V3P3D	-10 mA to +10 mA, -0.5 V to +4.6 V
Analog Input Pins	
IADC0, IADC1, IADC2, IADC3, IADC4, IADC5, IADC6, IADC7, VADC8, VADC9 and VADC10	-10 mA to +10 mA -0.5 V to V3P3A+0.5 V
XIN, XOUT	-10 mA to +10 mA -0.5 V to +3.0 V
DIO Pins	
Configured as Digital Inputs	-10 mA to +10 mA, -0.5 V to +6 V
Configured as Digital Outputs	-10 mA to +10 mA, -0.5 V to V3P3D+0.5 V
Digital Pins	
Inputs (PB, RESET, RX, ICE_E, TEST)	-10 mA to +10 mA, -0.5 to 6 V
Outputs (TX)	-10 mA to +10 mA, -0.5 V to V3P3D+0.5 V
Temperature and ESD Stress	
Operating junction temperature (peak, 100ms)	140 °C
Operating junction temperature (continuous)	125 °C
Storage temperature	45 °C to +165 °C
Solder temperature – 10 second duration	250 °C

6.2 Recommended External Components

Table 79: Recommended External Components

Name	From	To	Function	Value	Unit
C1	V3P3A	GNDA	Bypass capacitor for 3.3 V supply	0.1 20%	F
C2	V3P3D	GNDD	Bypass capacitor for 3.3 V output	0.1 20%	F
CSYS	V3P3SYS	GNDD	Bypass capacitor for V3P3SYS	1.0 30%	F
CVDD	VDD	GNDD	Bypass capacitor for VDD	0.1 20%	F
XTAL	XIN	XOUT	32.768 kHz crystal – electrically equivalent to ECS .327-12.5-17X or Vishay XT26T, load capacitance 12.5 pF	32.768	kHz
CXS	XIN	GNDA	Load capacitor values for crystal depend on crystal specifications and board parasitics. Nominal values are based on 4 pF board capacitance and include an allowance for chip capacitance.	15 10%	pF
CXL	XOUT	GNDA		10 10%	pF

6.3 Recommended Operating Conditions

Unless otherwise specified, all parameters listed under [6.4 Performance Specifications](#) and [6.5 Timing Specifications](#) are valid over the Recommended Operating Conditions provided in [Table 80](#) below.

Table 80: Recommended Operating Conditions

Parameter	Condition	Min	Typ	Max	Unit
V3P3SYS and V3P3A Supply Voltage for precision metering operation (MSN mode). Voltage at VBAT_RTC need not be present.	VBAT_RTC =0 V to 3.8 V	3.0		3.6	V
VBAT_RTC Voltage. VBAT_RTC is not needed to support the RTC and non-volatile memory unless V3P3SYS<2.0 V	V3P3SYS<2.0 V	2.0		3.8	V
Operating Temperature		-40		+85	°C
Notes:					
1. GNDA and GNDD must be connected together.					
2. V3P3SYS and V3P3A must be connected together.					

6.4 Performance Specifications

6.4.1 Input Logic Levels

Table 81: Input Logic Levels

Parameter	Condition	Min	Typ	Max	Unit
Digital high-level input voltage, V_{IH}		2			V
Digital low-level input voltage, V_{IL}				0.8	V
Input pull-up current, I_{IL} E_RXTX, E_RST, E_TCLK SPI_CSZ (DIO36) Other digital inputs	$V_{IN}=0$ V,	10		100	μ A
	ICE_E=3.3 V	10		100	μ A
		-1	0	1	μ A
Input pull down current, I_{IH} ICE_E, RESET, TEST Other digital inputs	$V_{IN}=V3P3D$	10		100	μ A
		-1	0	1	μ A

6.4.2 Output Logic Levels

Table 82: Output Logic Levels

Parameter	Condition	Min	Typ	Max	Unit
Digital high-level output voltage V_{OH}	$I_{LOAD} = 1$ mA	V3P3D-0.4			V
	$I_{LOAD} = 15$ mA (see notes 1, 2)	V3P3D-0.6			V
Digital low-level output voltage V_{OL}	$I_{LOAD} = 1$ mA	0		0.4	V
	$I_{LOAD} = 15$ mA (see note 1)	0		0.8	V
Note:					
1. Guaranteed by design; not production tested.					
2. Caution: The sum of all pull up currents must be compatible with the on-resistance of the internal V3P3D switch. See 6.4.6 V3P3D Switch on page 116.					

6.4.3 Battery Monitor

Table 83: Battery Monitor Performance Specifications ($TEMP_BAT = 1$)

Parameter	Condition	Min	Typ	Max	Unit
BV: Battery Voltage (definition)	MSN mode, $TEMP_PWR = 1$	$= 3.3 + (\quad - 142) \cdot 0.0246 + \quad \cdot 297$			V
Measurement Error $100 \frac{BV}{VBAT_RTC} - 1$	VBAT_RTC = 2.0 V	-7.5		7.5	%
	2.5 V	-5		5	%
	3.0 V	-3		3	%
	4.0 V	-3		5	%
Input impedance in continuous measurement, MSN mode. $V(VBAT_RTC)/I(VBAT_RTC)$	V3P3 = 3.3 V, $0x28A0[7] = 0$, $TEMP_PER = 111$, VBAT_RTC = 3.6 V,	1			M
Load applied with $BCURR$ $IBAT(BCURR=1) - IBAT(BCURR=0)$	V3P3 = 3.3 V	50	100	140	μ A

6.4.4 Temperature Monitor

Table 84. Temperature Monitor

Parameter	Condition	Min	Typ	Max	Unit
Temperature Measurement Equation for 71M6545 (see notes 2 and 4)	In MSN, $TEMP_PWR=1$: $\text{Temp} = 0.325 \cdot STEMP + 22$				°C
Temperature Measurement Equation for 71M6545H (see notes 3 and 4)	In MSN, $TEMP_PWR=1$: If $STEMP = 0$: $\text{Temp} = 0.325 \cdot STEMP + 22$ If $STEMP > 0$: $\text{Temp} = \frac{63 \cdot STEMP}{TEMP_85} + 22$				
Temperature Error (71M6545/H)	$T_A = 22 \text{ C}$	-2		2	°C
VBAT_RTC charge per measurement	$0x28A0[7] = 0$, $TEMP_PWR=0$, SLP Mode, $VBAT_RTC = 3.6 \text{ V}$		16		μC
Duration of temperature measurement after setting $TEMP_START$ (see note 1)			15	60	ms
Notes:					
<ol style="list-style-type: none"> 1. Guaranteed by design; not production tested. 2. For the 71M6545, $TEMP_85$ fuses read 0. 3. For the 71M6545H, $TEMP_85$ fuses 0. 4. The coefficients provided in these equations are typical. 					

6.4.5 Supply Current

The supply currents provided in below in [Table 85](#) include only the current consumed by the 71M6545/H. Refer to the *71M6xxx Data Sheet* for additional current required when using a 71M6x03 remote sensor.

Table 85: Supply Current Performance Specifications

Parameter	Condition	Min	Typ	Max	Unit
I1a: V3P3A + V3P3SYS current, Normal Operation	Polyphase: 4 Currents, 3 Voltages V3P3A = V3P3SYS = 3.3 V, MPU_DIV [2:0]= 3 (614 kHz MPU clock), No Flash memory write, RTM_E=0, PRE_E=0, CE_E=1, ADC_E=1, ADC_DIV=0, MUX_DIV[3:0]=7, FIR_LEN[1:0]=1, PLL_FAST=1		7.2	8.5	mA
I1b: V3P3A + V3P3SYS current, Normal Operation PLL_FAST=0	Same as I1a, except PLL_FAST=0		2.9	3.8	mA
I1c: V3P3A + V3P3SYS current, Normal Operation PRE_E=1	Same as I1a, except PRE_E=1		7.3	8.7	mA
I1d: V3P3A + V3P3SYS current, Normal Operation PRE_E=1, ADC_DIV=1, FIR_LEN=0. (see note 1)	Same as I1a, except PRE_E=1, ADC_DIV=1, FIR_LEN=0.		6.5	7.5	mA
I1e: V3P3A + V3P3SYS current, Normal Operation PLL_FAST=0, PRE_E=1. (see note 1)	Same as I1a, except PRE_E=1, PLL_FAST=0.		3.0	3.9	mA
I2: V3P3A + V3P3SYS dynamic current	Same as I1a, except with variation of MPU_DIV[2:0]. $\frac{I_{MPU_DIV\ 0} - I_{MPU_DIV\ 3}}{4.3}$		0.4	0.6	mA/ MHz
VBAT_RTC current I3a: MSN I3b: SLP Mode I3c: SLP Mode (see note 1)	T _A = 25 °C T _A = 85 °C	-300	0 0.7 1.5	300 1.7 3.2	nA μA μA
I4: V3P3A + V3P3SYS current, Write Flash with ICE	Same as I1, except write Flash at maximum rate, CE_E=0, ADC_E=0.		7.1	8.7	mA
Note: 1. Guaranteed by design; not production tested.					

6.4.6 V3P3D Switch

Table 86: V3P3D Switch Performance Specifications

Parameter	Condition	Min	Typ	Max	Unit
On resistance – V3P3SYS to V3P3D	I _{V3P3D} 1 mA			10	
V3P3D I _{OH} , MSN	V3P3SYS = 3V V3P3D = 2.9V	10			mA

6.4.7 Internal Power Fault Comparators

Parameter	Condition	Min	Typ	Max	Unit
Overall response time	100mV overdrive, falling 100mV overdrive, rising	20		200 200	s s
Falling Threshold 3.0 V Comparator 2.8 V Comparator Difference 3.0V and 2.8V Comparators	V3P3 falling	2.83 2.75 50	2.93 2.81 136	3.03 2.87 220	V V mV
Falling Threshold 2.25 V Comparator 2.0 V Comparator Difference 2.25V and 2.0V Comparators	VDD falling	2.2 1.90 0.15	2.25 2.00 0.25	2.5 2.20 0.35	V V V
Hysteresis, (Rising Threshold - Falling Threshold) 3.0 V Comparator 2.8 V Comparator 2.25 V Comparator 2.0 V Comparator	T _A = 22 °C	22 25 10 10	45 42 33 28	65 60 60 60	mV mV mV mV

6.4.8 2.5 V Voltage Regulator – System Power

Table 87: 2.5 V Voltage Regulator Performance Specifications (VDD pin)

Parameter	Condition	Min	Typ	Max	Unit
V2P5	V3P3 = 3.0 V - 3.8 V I _{LOAD} = 0 mA	2.55	2.65	2.75	V
V2P5 load regulation	V3P3 = 3.3 V I _{LOAD} = 0 mA to 5 mA			40	mV
Voltage overhead V3P3SYS-V2P5	I _{LOAD} = 5 mA, Reduce V3P3D until V2P5 drops 200 mV			440	mV

6.4.9 Crystal Oscillator

Measurement conditions: Crystal disconnected, test load of 200 pF/100 k Ω between XOUT and GNDD.

Table 88: Crystal Oscillator Performance Specifications

Parameter	Condition	Min	Typ	Max	Unit
Maximum Output Power to Crystal	Crystal connected, see note 1			1	μ W
XIN to XOUT Capacitance (see note 1)				3	pF
Capacitance change on XOUT	RTCA_ADJ = 7F to 0, Bias voltage = unbiased V _{pp} = 0.1 V		15		pF
Note: 1. Guaranteed by design; not production tested.					

6.4.10 Phase-Locked Loop (PLL)

Table 89: PLL Performance Specifications

PARAMETER	CONDITION	MIN	TYP	MAX	UNIT
PLL Power-up Settling Time	<i>PLL_FAST</i> =0, V3P3 = 0 to 3.3 V step Measured from first edge of MCK (TMUX2OUT pin)		3		ms
PLL_FAST settling time	V3P3=0				
PLL_FAST rise			3		ms
PLL_FAST fall			3		ms
PLL SLP to MSN Settling Time	<i>PLL_FAST</i> =0		3		ms

6.4.11 71M6545/H VREF

Table 90 shows the performance specifications for the 71M6545/H ADC reference voltage (VREF).

Table 90: 71M6545/H VREF Performance Specifications

Parameter	Condition	Min	Typ	Max	Unit
VREF output voltage, VREF(22)	$T_A = 22\text{ }^\circ\text{C}$	1.193	1.195	1.197	V
VREF output voltage, VREF(22)	$PLL_FAST=0$		1.195		V
VREF chop step, trimmed	VREF(CHOP=01) – VREF(CHOP=10)	-10		10	mV
VREF power supply sensitivity $VREF / V3P3A$	$V3P3A = 3.0\text{ to }3.6\text{ V}$	-1.5		1.5	mV/V
VREF input impedance	$VREF_DIS = 1,$ $VREF = 1.3\text{ V to }1.7\text{ V}$	100			k
VREF output impedance	$VREF_CAL = 1,$ $I_{LOAD} = 10\text{ }\mu\text{A}, -10\text{ }\mu\text{A}$			3.2	k
VNOM definition (see note 2)	$VNOM(T) = VREF(22) + (T - 22)TC1 + (T - 22)^2TC2$				V
If temperature characterization trim information is available (71M6545H)					
VNOM temperature coefficients: TC1 =	$35.091 + 0.01764 \cdot TRIMT + 1.587 \cdot (TRIMBGB - TRIMBGD)$				$\mu\text{V}/^\circ\text{C}$
TC2 =	$-0.557 - 2.8 \cdot 10^{-4} \cdot TRIMT$				$\mu\text{V}/^\circ\text{C}^2$
VREF(T) deviation from VNOM(T) (see note 1): $\frac{VREF(T) - VNOM(T)}{VNOM(T)} \cdot 10^6$		-10		+10	ppm/ $^\circ\text{C}$
If temperature characterization trim information is not available (71M6545H)					
VNOM temperature coefficients: TC1 =	$275 + 4.95 \cdot TRIMT$				$\mu\text{V}/^\circ\text{C}$
TC2 =	$0.557 + 0.00028 \cdot TRIMT$				$\mu\text{V}/^\circ\text{C}^2$
VREF(T) deviation from VNOM(T) (see note 1): $\frac{VREF(T) - VNOM(T)}{VNOM(T)} \cdot 10^6$		-40		+40	ppm/ $^\circ\text{C}$
VREF aging			25		ppm/year
Notes:					
1. Guaranteed by design; not production tested.					
2. This relationship describes the nominal behavior of VREF at different temperatures, as governed by a second order polynomial of 1 st and 2 nd order coefficients TC1 and TC2.					
3. For the parameters in this table, unless otherwise specified, $VREF_DIS = 0$, $PLL_FAST=1$					

6.4.12 ADC Converter (71M6545/H)

Table 91: ADC Converter Performance Specifications

Parameter	Condition	Min	Typ	Max	Unit																																																																																						
Recommended Input Range ($V_{in} - V_{3P3A}$)		-250		250	mV peak																																																																																						
Voltage to Current Crosstalk $\frac{10^6 * V_{crosstalk}}{V_{in}} \cos(V_{in} - V_{crosstalk})$ (see note 1)	$V_{in} = 200$ mV peak, 65 Hz, on VADC8 (VA) or VADC9 (VB) or VADC10 (VC). $V_{crosstalk}$ = largest measurement on IADC0-1 or IADC2-3 or IADC4-5 or IADC6-7	-10		10	$\mu V/V$																																																																																						
Input Impedance, no pre-amp	$V_{in}=65$ Hz	40		90	k																																																																																						
ADC Gain Error vs %Power Supply Variation $\frac{10^6 N_{out_PK} 357nV / V_{IN}}{100 V_{3P3A} / 3.3}$	$V_{in}=200$ mV pk, 65 Hz $V_{3P3A}=3.0$ V, 3.6 V			50	ppm / %																																																																																						
Input Offset IADC0=IADC1=V3P3A IADC0=V3P3A	$DIFF0_E=1, PRE_E=0$ $DIFF0_E=0, PRE_E=0$	-10 -10		10 10	mV mV																																																																																						
THD @ 250mVpk <table border="1" data-bbox="203 976 636 1144"> <thead> <tr> <th>Name</th> <th>FIR_LEN</th> <th>ADC_DIV</th> <th>PLL_FAST</th> <th>MUX_DIV</th> </tr> </thead> <tbody> <tr><td>A</td><td>0</td><td>0</td><td>0</td><td>3</td></tr> <tr><td>B</td><td>1</td><td>0</td><td>0</td><td>2</td></tr> <tr><td>C</td><td>0</td><td>0</td><td>1</td><td>11</td></tr> <tr><td>D</td><td>1</td><td>0</td><td>1</td><td>6</td></tr> <tr><td>E</td><td>2</td><td>0</td><td>1</td><td>4</td></tr> <tr><td>F</td><td>0</td><td>1</td><td>0</td><td>2</td></tr> <tr><td>G</td><td>0</td><td>1</td><td>1</td><td>6</td></tr> <tr><td>H</td><td>1</td><td>1</td><td>1</td><td>3</td></tr> <tr><td>J</td><td>2</td><td>1</td><td>1</td><td>2</td></tr> </tbody> </table>	Name	FIR_LEN	ADC_DIV	PLL_FAST	MUX_DIV	A	0	0	0	3	B	1	0	0	2	C	0	0	1	11	D	1	0	1	6	E	2	0	1	4	F	0	1	0	2	G	0	1	1	6	H	1	1	1	3	J	2	1	1	2	$V_{IN} = 65$ Hz, 250mVpk, 64kpts FFT, Blackman Harris Window.		<table border="1" data-bbox="1096 966 1193 1123"> <tbody> <tr><td>A</td><td></td></tr> <tr><td>B</td><td>-82</td></tr> <tr><td>C</td><td></td></tr> <tr><td>D</td><td>-84</td></tr> <tr><td>E</td><td></td></tr> <tr><td>F</td><td>-83</td></tr> <tr><td>G</td><td></td></tr> <tr><td>H</td><td>-86</td></tr> <tr><td>J</td><td></td></tr> </tbody> </table> <table border="1" data-bbox="1226 966 1323 1123"> <tbody> <tr><td>A</td><td>-75</td></tr> <tr><td>B</td><td>-75</td></tr> <tr><td>C</td><td>-75</td></tr> <tr><td>D</td><td>-75</td></tr> <tr><td>E</td><td>-75</td></tr> <tr><td>F</td><td>-75</td></tr> <tr><td>G</td><td>-75</td></tr> <tr><td>H</td><td>-75</td></tr> <tr><td>J</td><td>-75</td></tr> </tbody> </table>	A		B	-82	C		D	-84	E		F	-83	G		H	-86	J		A	-75	B	-75	C	-75	D	-75	E	-75	F	-75	G	-75	H	-75	J	-75		dB
Name	FIR_LEN	ADC_DIV	PLL_FAST	MUX_DIV																																																																																							
A	0	0	0	3																																																																																							
B	1	0	0	2																																																																																							
C	0	0	1	11																																																																																							
D	1	0	1	6																																																																																							
E	2	0	1	4																																																																																							
F	0	1	0	2																																																																																							
G	0	1	1	6																																																																																							
H	1	1	1	3																																																																																							
J	2	1	1	2																																																																																							
A																																																																																											
B	-82																																																																																										
C																																																																																											
D	-84																																																																																										
E																																																																																											
F	-83																																																																																										
G																																																																																											
H	-86																																																																																										
J																																																																																											
A	-75																																																																																										
B	-75																																																																																										
C	-75																																																																																										
D	-75																																																																																										
E	-75																																																																																										
F	-75																																																																																										
G	-75																																																																																										
H	-75																																																																																										
J	-75																																																																																										
THD @ 20mVpk <table border="1" data-bbox="203 1176 636 1344"> <thead> <tr> <th>Name</th> <th>FIR_LEN</th> <th>ADC_DIV</th> <th>PLL_FAST</th> <th>MUX_DIV</th> </tr> </thead> <tbody> <tr><td>A</td><td>0</td><td>0</td><td>0</td><td>3</td></tr> <tr><td>B</td><td>1</td><td>0</td><td>0</td><td>2</td></tr> <tr><td>C</td><td>0</td><td>0</td><td>1</td><td>11</td></tr> <tr><td>D</td><td>1</td><td>0</td><td>1</td><td>6</td></tr> <tr><td>E</td><td>2</td><td>0</td><td>1</td><td>4</td></tr> <tr><td>F</td><td>0</td><td>1</td><td>0</td><td>2</td></tr> <tr><td>G</td><td>0</td><td>1</td><td>1</td><td>6</td></tr> <tr><td>H</td><td>1</td><td>1</td><td>1</td><td>3</td></tr> <tr><td>J</td><td>2</td><td>1</td><td>1</td><td>2</td></tr> </tbody> </table>	Name	FIR_LEN	ADC_DIV	PLL_FAST	MUX_DIV	A	0	0	0	3	B	1	0	0	2	C	0	0	1	11	D	1	0	1	6	E	2	0	1	4	F	0	1	0	2	G	0	1	1	6	H	1	1	1	3	J	2	1	1	2	$V_{IN} = 65$ Hz, 20mVpk, 64kpts FFT, Blackman Harris Window.		<table border="1" data-bbox="1096 1165 1193 1323"> <tbody> <tr><td>A</td><td>-85</td></tr> <tr><td>B</td><td>-91</td></tr> <tr><td>C</td><td>-85</td></tr> <tr><td>D</td><td>-91</td></tr> <tr><td>E</td><td>-93</td></tr> <tr><td>F</td><td>-85</td></tr> <tr><td>G</td><td>-85</td></tr> <tr><td>H</td><td>-91</td></tr> <tr><td>J</td><td>-93</td></tr> </tbody> </table>	A	-85	B	-91	C	-85	D	-91	E	-93	F	-85	G	-85	H	-91	J	-93		dB																		
Name	FIR_LEN	ADC_DIV	PLL_FAST	MUX_DIV																																																																																							
A	0	0	0	3																																																																																							
B	1	0	0	2																																																																																							
C	0	0	1	11																																																																																							
D	1	0	1	6																																																																																							
E	2	0	1	4																																																																																							
F	0	1	0	2																																																																																							
G	0	1	1	6																																																																																							
H	1	1	1	3																																																																																							
J	2	1	1	2																																																																																							
A	-85																																																																																										
B	-91																																																																																										
C	-85																																																																																										
D	-91																																																																																										
E	-93																																																																																										
F	-85																																																																																										
G	-85																																																																																										
H	-91																																																																																										
J	-93																																																																																										
LSB Size: <table border="1" data-bbox="203 1396 636 1564"> <thead> <tr> <th>Name</th> <th>FIR_LEN</th> <th>ADC_DIV</th> <th>PLL_FAST</th> <th>MUX_DIV</th> </tr> </thead> <tbody> <tr><td>A</td><td>0</td><td>0</td><td>0</td><td>3</td></tr> <tr><td>B</td><td>1</td><td>0</td><td>0</td><td>2</td></tr> <tr><td>C</td><td>0</td><td>0</td><td>1</td><td>11</td></tr> <tr><td>D</td><td>1</td><td>0</td><td>1</td><td>6</td></tr> <tr><td>E</td><td>2</td><td>0</td><td>1</td><td>4</td></tr> <tr><td>F</td><td>0</td><td>1</td><td>0</td><td>2</td></tr> <tr><td>G</td><td>0</td><td>1</td><td>1</td><td>6</td></tr> <tr><td>H</td><td>1</td><td>1</td><td>1</td><td>3</td></tr> <tr><td>J</td><td>2</td><td>1</td><td>1</td><td>2</td></tr> </tbody> </table>	Name	FIR_LEN	ADC_DIV	PLL_FAST	MUX_DIV	A	0	0	0	3	B	1	0	0	2	C	0	0	1	11	D	1	0	1	6	E	2	0	1	4	F	0	1	0	2	G	0	1	1	6	H	1	1	1	3	J	2	1	1	2	$V_{in}=65$ Hz, 20mVpk, 64kpts FFT, Blackman- Harris window		<table border="1" data-bbox="1096 1375 1193 1585"> <tbody> <tr><td>A</td><td>3470</td></tr> <tr><td>B</td><td>406</td></tr> <tr><td>C</td><td>3040</td></tr> <tr><td>D</td><td>357</td></tr> <tr><td>E</td><td>151</td></tr> <tr><td>F</td><td>3470</td></tr> <tr><td>G</td><td>3040</td></tr> <tr><td>H</td><td>357</td></tr> <tr><td>J</td><td>151</td></tr> </tbody> </table>	A	3470	B	406	C	3040	D	357	E	151	F	3470	G	3040	H	357	J	151		nV																		
Name	FIR_LEN	ADC_DIV	PLL_FAST	MUX_DIV																																																																																							
A	0	0	0	3																																																																																							
B	1	0	0	2																																																																																							
C	0	0	1	11																																																																																							
D	1	0	1	6																																																																																							
E	2	0	1	4																																																																																							
F	0	1	0	2																																																																																							
G	0	1	1	6																																																																																							
H	1	1	1	3																																																																																							
J	2	1	1	2																																																																																							
A	3470																																																																																										
B	406																																																																																										
C	3040																																																																																										
D	357																																																																																										
E	151																																																																																										
F	3470																																																																																										
G	3040																																																																																										
H	357																																																																																										
J	151																																																																																										
Digital Full-Scale: <table border="1" data-bbox="203 1648 636 1816"> <thead> <tr> <th>Name</th> <th>FIR_LEN</th> <th>ADC_DIV</th> <th>PLL_FAST</th> <th>MUX_DIV</th> </tr> </thead> <tbody> <tr><td>A</td><td>0</td><td>0</td><td>0</td><td>3</td></tr> <tr><td>B</td><td>1</td><td>0</td><td>0</td><td>2</td></tr> <tr><td>C</td><td>0</td><td>0</td><td>1</td><td>11</td></tr> <tr><td>D</td><td>1</td><td>0</td><td>1</td><td>6</td></tr> <tr><td>E</td><td>2</td><td>0</td><td>1</td><td>4</td></tr> <tr><td>F</td><td>0</td><td>1</td><td>0</td><td>2</td></tr> <tr><td>G</td><td>0</td><td>1</td><td>1</td><td>6</td></tr> <tr><td>H</td><td>1</td><td>1</td><td>1</td><td>3</td></tr> <tr><td>J</td><td>2</td><td>1</td><td>1</td><td>2</td></tr> </tbody> </table>	Name	FIR_LEN	ADC_DIV	PLL_FAST	MUX_DIV	A	0	0	0	3	B	1	0	0	2	C	0	0	1	11	D	1	0	1	6	E	2	0	1	4	F	0	1	0	2	G	0	1	1	6	H	1	1	1	3	J	2	1	1	2					A: ± 91125 B: ± 778688 C: ± 103823 D: ± 884736 E: ± 2097152 F: ± 91125 G: ± 103823 H: ± 884736 J: ± 2097152	LSB																																			
Name	FIR_LEN	ADC_DIV	PLL_FAST	MUX_DIV																																																																																							
A	0	0	0	3																																																																																							
B	1	0	0	2																																																																																							
C	0	0	1	11																																																																																							
D	1	0	1	6																																																																																							
E	2	0	1	4																																																																																							
F	0	1	0	2																																																																																							
G	0	1	1	6																																																																																							
H	1	1	1	3																																																																																							
J	2	1	1	2																																																																																							

Note:

1. Guaranteed by design; not production tested.
2. Unless stated otherwise, the following test conditions apply to all the parameters provided in this table: *FIR_LEN[1:0]=1*, *VREF_DIS=0*, *PLL_FAST=1*, *ADC_DIV=0*, *MUX_DIV=6*, LSB values do not include the 9-bit left shift at CE input.

6.4.13 Pre-Amplifier for IADC0-IADC1**Table 92: Pre-Amplifier Performance Specifications**

PARAMETER	CONDITION	MIN	TYP	MAX	UNIT
Differential Gain Vin=30mV differential Vin=15mV differential (see note 1)	T _A = 5 C, V3P3=3.3 V, PRE_E=1, FIR_LEN=2, DIFF0_E=1, 2520Hz sample rate	7.8 7.8	7.92 7.92	8.0 8.0	V/V V/V
Gain Variation vs V3P3 Vin=30mV differential (see note 1)	V3P3 = 2.97 V, 3.63 V	-100		100	ppm/%
Gain Variation vs Temp Vin=30mV differential (see note 1)	T _A = -40 C, 85 C	10	-25	-80	ppm/C
Phase Shift, Vin=30mV differential (see note 1)	T _A =25 C, V3P3=3.3 V	-6		6	m°
Preamp input current IADC0 IADC1	PRE_E=1, FIR_LEN=10, DIFF0_E=1 2520Hz sample rate, IADC0=IADC1=V3P3	4 4	9 9	16 16	uA uA
Preamp+ADC THD Vin=30mV differential Vin=15mV differential	T _A =25 C, V3P3=3.3 V, PRE_E=1, FIR_LEN=2, DIFF0_E=1, 2520Hz sample rate.		-82 -86		dB dB
Preamp Offset IADC0=IADC1=V3P3+30mV IADC0=IADC1= V3P3+15mV IADC0=IADC1= V3P3 IADC0=IADC1= V3P3-15mV IADC0=IADC1= V3P3-30mV	T _A =25 C, V3P3=3.3 V, PRE_E=1, FIR_LEN=10, DIFF0_E=1, 2520Hz sample rate		-0.63 -0.57 -0.56 -0.56 -0.55		mV mV mV mV mV
Note:	1. Guaranteed by design; not production tested.				

6.5 Timing Specifications

6.5.1 Flash Memory

Table 93: Flash Memory Timing Specifications

Parameter	Condition	Min	Typ	Max	Unit
Flash write cycles	-40 °C to +85 °C	20,000			Cycles
Flash data retention	25 °C 85 °C	100 10			Years
Flash byte writes between page or mass erase operations				2	Cycles
Write Time per Byte				21	µs
Page Erase (1024 bytes)				21	ms
Mass Erase				21	ms

6.5.2 SPI Slave

Table 94. SPI Slave Timing Specifications

Parameter	Condition	Min	Typ	Max	Unit
SPI Setup Time	SPI_DI to SPI_CK rise	10			ns
SPI Hold Time	SPI_CK rise to SPI_DI	10			ns
SPI Output Delay	SPI_CK fall to SPI_D0			40	ns
SPI Recovery Time	SPI_CSZ fall to SPI_CK	10			ns
SPI Removal Time	SPI_CK to SPI_CSZ rise	15			ns
SPI Clock High		40			ns
SPI Clock Low		40			ns
SPI Clock Freq	SPI Freq/MPU Freq			2.0	MHz/MHz
SPI Transaction Space	SPI_CSZ rise to SPI_CSZ fall	4.5			MPU Cycles

6.5.3 EEPROM Interface

Table 95: EEPROM Interface Timing

Parameter	Condition	Min	Typ	Max	Unit
Write Clock frequency (I ² C)	CKMPU = 4.9 MHz, Using interrupts		310		kHz
	CKMPU = 4.9 MHz, bit-banging DIO2/3 <i>PLL_FAST</i> = 0		100		kHz
Write Clock frequency (3-wire)	CKMPU = 4.9 MHz <i>PLL_FAST</i> = 0 <i>PLL_FAST</i> = 1		160 500		kHz

6.5.4 RESET Pin

Table 96: RESET Pin Timing

Parameter	Condition	Min	Typ	Max	Unit
Reset pulse width		5			μs
Reset pulse fall time (see note 1)				1	μs
Note:					
1. Guaranteed by design; not production tested.					

6.5.5 Real-Time Clock (RTC)

Table 97: RTC Range for Date

Parameter	Condition	Min	Typ	Max	Unit
Range for date		2000	–	2255	year

6.6 64-Pin LQFP Package Outline Drawing

Controlling dimensions are in mm.

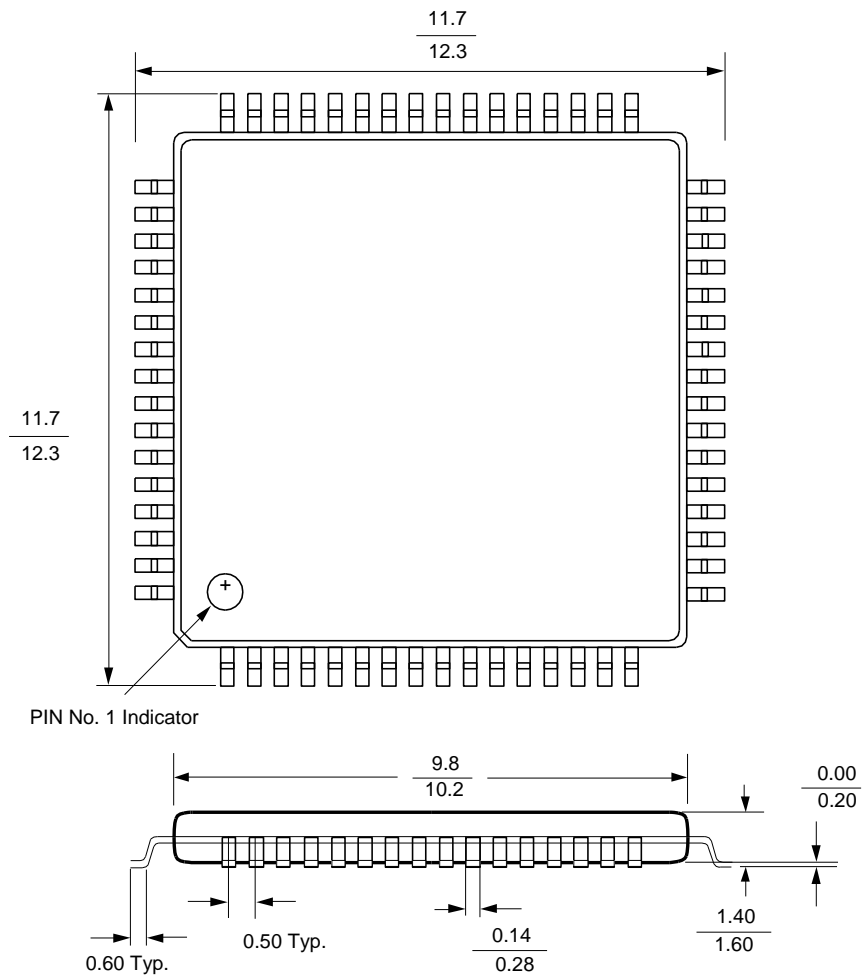

Figure 37: 64-pin LQFP Package Outline

6.7 71M6545/H Pinout

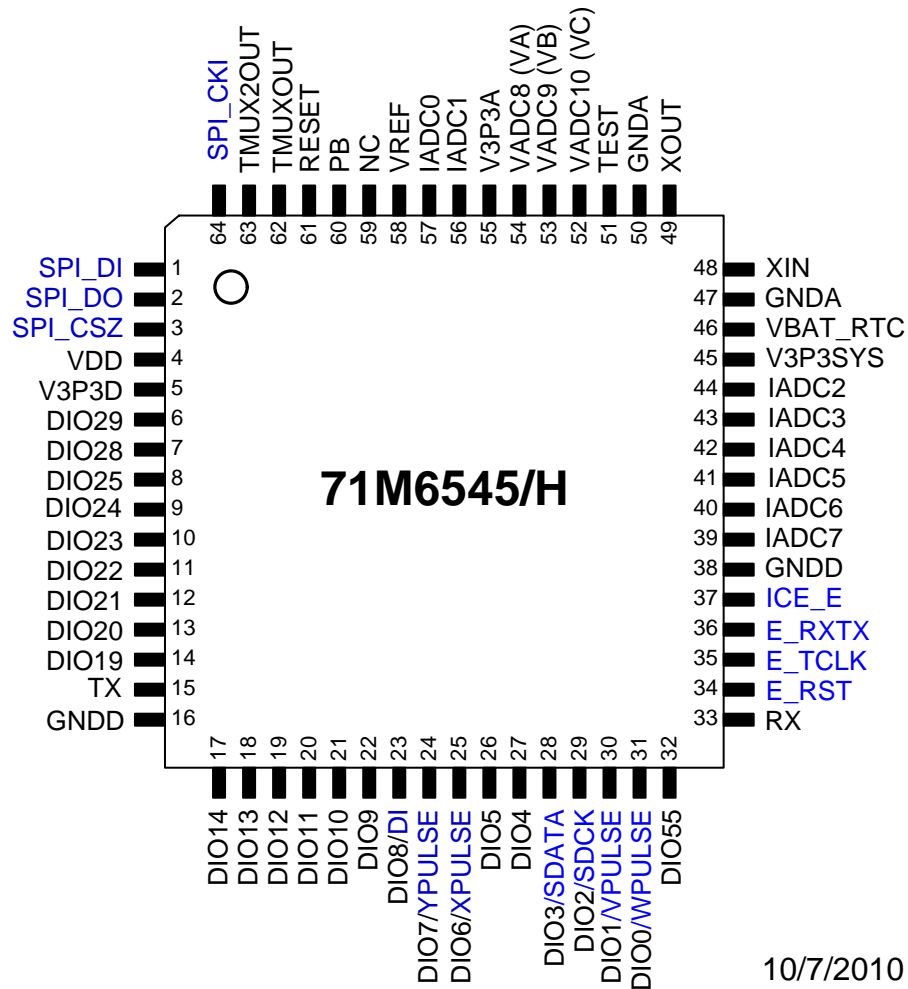

Figure 38: Pinout for the LQFP-64 Package

6.8 71M6545/H Pin Descriptions

6.8.1 71M6545/H Power and Ground Pins

Table 98 lists the power and ground pins. Pin types: P = Power, O = Output. The circuit number denotes the equivalent circuit, as specified under [6.8.4](#).

Table 98: 71M6545/H Power and Ground Pins

Pin No.	Name	Type	Circuit	Description
47, 50	GNDA	P	–	Analog ground: This pin should be connected directly to the ground plane.
16, 38	GNDD	P	–	Digital ground: This pin is connected directly to the ground plane.
55	V3P3A	P	–	Analog power supply: A 3.3 V power supply is connected to this pin. V3P3A must be the same voltage as V3P3SYS.
45	V3P3SYS	P	–	System 3.3 V supply. This pin is connected to a 3.3 V power supply.
5	V3P3D	O	13	Auxiliary voltage output of the chip. In mission mode, this pin is connected to V3P3SYS by the internal selection switch. A bypass capacitor to ground must not exceed 0.1 μ F.
4	VDD	O	10	The output of the 2.5V regulator. This pin is powered in MSN mode. A 0.1 μ F bypass capacitor to ground must be connected to this pin.
46	VBAT_RTC	P	12	RTC and oscillator power supply. A battery may be optionally connected between VBAT_RTC and GNDD. If no battery is used, connect VBAT_RTC to V3P3SYS.

6.8.2 71M6545/H Analog Pins

Table 99 lists the analog pins. Pin types: O = Output, I = Input. The circuit number denotes the equivalent circuit, as specified in 6.8.4.

Table 99: 71M6545/H Analog Pins

Pin No.	Name	Type	Circuit	Description		
57 56	IADC0 IADC1	I	6	Differential or single-ended Analog Line Current Sense Inputs: These pins are voltage inputs to the internal A/D converter. Typically, they are connected to the outputs of current sensors. Unused pins must be tied to V3P3A.		
44 43	IADC2 IADC3			When configured as differential inputs (i.e., by setting the <i>DIFF_x_E</i> control bits, where x=0, 2, 4, 6), pins are paired to form differential inputs pairs: IADC0-IADC1, IADC2-IADC3, IADC4-IADC5, and IADC6-IADC7.		
42 41	IADC4 IADC5			IADC2-IADC3, IADC4-IADC5 and IADC6-IADC7 may be configured for communication with the 71M6xx3 remote isolated sensor interface (i.e., by setting the <i>RMT_x_E</i> control bits, where x=2, 4, 6). When configured as remote sensor interfaces, these pins form balanced digital pairs for bi-directional digital communications with a 71M6xx3 remote isolated sensor.		
40 39	IADC6 IADC7					
54 53 52	VADC8 (VA) VADC9 (VB) VADC10 (VC)			I	6	Line Voltage Sense Inputs: These pins are voltage inputs to the internal A/D converter. Typically, they are connected to the outputs of resistor dividers. Unused pins must be tied to V3P3A.
58	VREF			O	9	Voltage Reference for the ADC. This pin must be left unconnected (floating). The VREF pin must be kept turned off for normal operation (see <i>VREF_CAL</i> , <i>I/O RAM 0x2704[7]</i>).
48 49	XIN XOUT	I O	8	Crystal Inputs: A 32 kHz crystal should be connected across these pins. Typically, a 15 pF capacitor is also connected from XIN to GNDA and a 10 pF capacitor is connected from XOUT to GNDA. It is important to minimize the capacitance between these pins. See the crystal manufacturer datasheet for details. If an external clock is used, a 150 mV (p-p) clock signal should be applied to XIN, and XOUT should be left unconnected.		

6.8.3 71M6545/H Digital Pins

Table 100 lists the digital pins. Pin types: O = Output, I = Input, I/O = Input/Output, N/C = no connect. The circuit number denotes the equivalent circuit, as specified in 6.8.4.

Table 100: 71M6545/H Digital Pins

Pin No.	Name	Type	Circuit	Description
31	DIO0/WPULSE	I/O	3, 4	Multiple-Use Pins. Configurable as DIO or its alternate function. Alternate functions with proper selection of associated I/O RAM registers are: DIO0 = WPULSE (31) DIO1 = VPULSE (30) DIO2 = SDCK (29) DIO3 = SDATA (28) DIO6 = XPULSE (25) DIO7 = YPULSE (24) DIO8 = DI (23) Unused pins must be configured as outputs or terminated to V3P3/GNDD.
30	DIO1/VPULSE			
29	DIO2/SDCK			
28	DIO3/SDATA			
27	DIO4			
26	DIO5			
25	DIO6/XPULSE			
24	DIO7/YPULSE			
23	DIO8/DI			
17–22	DIO[14:9]			
8–14	DIO[25:19]			
6–7	DIO[29:28]			
32	DIO55			
3	SPI_CSZ	I	3, 4	SPI interface pins.
2	SPI_DO	O		
1	SPI_DI	I		
64	SPI_CK1	I		
36	E_RXTX	I/O	1, 4	Emulator port pins. These pins are activated when the ICE_E pin is pulled high.
34	E_RST	I/O	4	
35	E_TCLK	O		
37	ICE_E	I	2	ICE enable. For production units, this pin should be pulled to GND to disable the emulator port.
62	TMUXOUT	O	4	Multiplexer/clock output pins.
63	TMUX2OUT			
61	RESET	I	2	Chip reset: This input pin is used to reset the chip into a known state. For normal operation, this pin is pulled low. To reset the chip, this pin is pulled high. This pin has an internal 30 µA (nominal) current source pull-down. No external reset circuitry is necessary.
33	RX	I	3	UART0 input. If this pin is unused it must be terminated to V3P3D or GNDD.
15	TX	O	4	UART0 output.
51	TEST	I	7	Enables Production Test. This pin must be grounded in normal operation.
60	PB	I	3	Push button input. This pin must be at GNDD when not active or unused. PB does not have an internal pull-up or pull-down resistor.
59	NC	N/C	--	Do not connect this pin.

6.8.4 I/O Equivalent Circuits

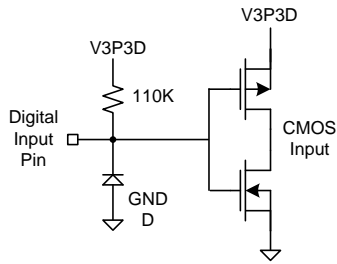

Digital Input Equivalent Circuit Type 1:
Standard Digital Input or pin configured as DIO Input with Internal Pull-Up

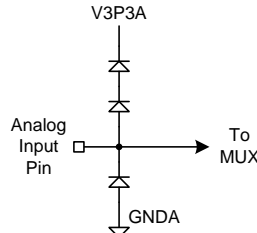

Analog Input Equivalent Circuit Type 6:
ADC Input

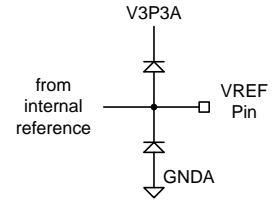

VREF Equivalent Circuit Type 9:
VREF

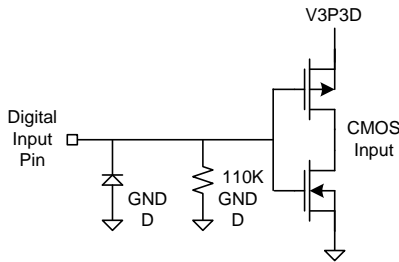

Digital Input Type 2:
Pin configured as DIO Input with Internal Pull-Down

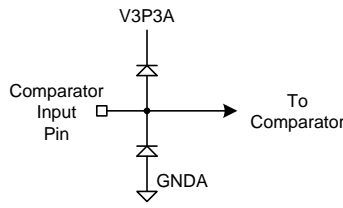

Comparator Input Equivalent Circuit Type 7:
Comparator Input

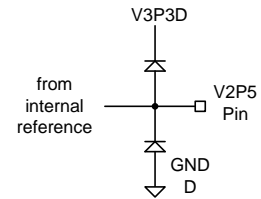

V2P5 Equivalent Circuit Type 10:
V2P5

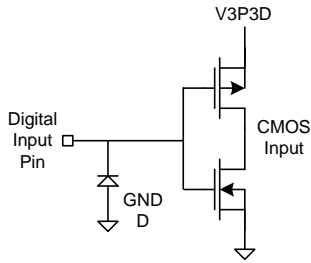

Digital Input Type 3:
Standard Digital Input or pin configured as DIO Input

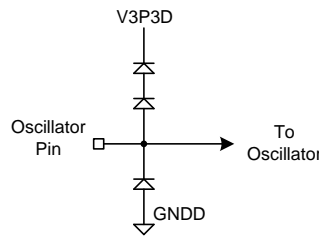

Oscillator Equivalent Circuit Type 8:
Oscillator I/O

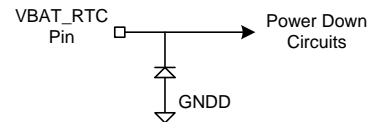

VBAT_RTC Equivalent Circuit Type 12:
VBAT_RTC Power

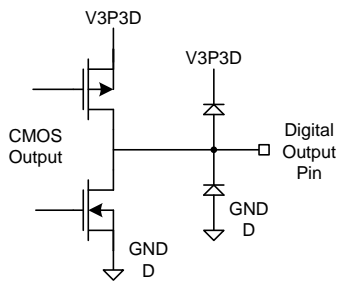

Digital Output Equivalent Circuit Type 4:
Standard Digital Output or pin configured as DIO Output

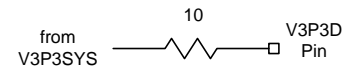

V3P3D Equivalent Circuit Type 13:
V3P3D

Figure 39: I/O Equivalent Circuits

7 Ordering Information

7.1 71M6545/H Ordering Guide

Refer to the 71M6xxx Data Sheet for the 71M6xx3 ordering guide information.

Table 101. 71M6545/H Ordering Guide

PART	PART DESCRIPTION (PACKAGE, TYPICAL ACCURACY)	FLASH (KB)/RAM (KB) SIZE	PACKAGING	ORDER NUMBER	PACKAGE MARKING
71M6545	64 LQFP Lead(Pb)-Free, 0.1%	32/3	Bulk	71M6545-IGT/F	71M6545-IGT
71M6545	64 LQFP Lead(Pb)-Free, 0.1%	32/3	Tape and Reel	71M6545-IGTR/F	71M6545-IGT
71M6545H*	64 LQFP Lead(Pb)-Free, 0.1%	64/5	Bulk	71M6545H-IGT/F	71M6545H-IGT
71M6545H*	64 LQFP Lead(Pb)-Free, 0.1%	64/5	Tape and Reel	71M6545H-IGTR/F	71M6545H-IGT

*Future product—contact factory for availability.

8 Related Information

The following documents related to the 71M6545/H and 71M6xx3 are available:

71M6545/H Data Sheet (this document)

71M6xxx Data Sheet

71M654x Software User's Guide (SUG)

9 Contact Information

For technical support or more information about Silergy products, contact technical support at support.metering@silergy.com

Appendix A: Acronyms

AFE	Analog Front End
AMR	Automatic Meter Reading
ANSI	American National Standards Institute
CE	Compute Engine
DIO	Digital I /O
DSP	Digital Signal Processor
FIR	Finite Impulse Response
I ² C	Inter-IC Bus
ICE	In-Circuit Emulator
IEC	International Electrotechnical Commission
MPU	Microprocessor Unit (CPU)
PLL	Phase-locked loop
RMS	Root Mean Square
SFR	Special Function Register
SPI	Serial Peripheral Interface
TOU	Time of Use
UART	Universal Asynchronous Receiver/Transmitter

Appendix B: Revision History

REVISION NUMBER	REVISION DATE	DESCRIPTION	PAGES CHANGED
1.0	4/11	Initial release	—
2	10/13	Replaced Figure 12, updated PLS_INV description on Table 61, updated document footers, added warning note on SPI Flash Mode section, updated IEN0 Bit Function and External MPU Interrupts table, changed CECONFIG bit 23 to reserved, corrected SPI Slave port diagram (Figure 20), updated the text description of the Signal Input Pins section, combined columns 3 and 4 of Table 32, updated the Interrupt Structure diagram, updated the required CE code and settings notes about MUX_DIV[3:0], added a note about V_ANG_CNT under Table 74	All
3	4/16	Rebranding only	

Copyright © 2016 Silergy Corp Proprietary information. For Silergy customer use only. Unauthorized distribution or duplication prohibited. Silergy cannot assume responsibility for use of any circuitry other than circuitry entirely embodied in a Silergy product. No circuit patent licenses are implied. Silergy reserves the right to change the circuitry and specifications without notice at any time. Typical parametric values provided in this data sheet are for guidance only and are not guaranteed.

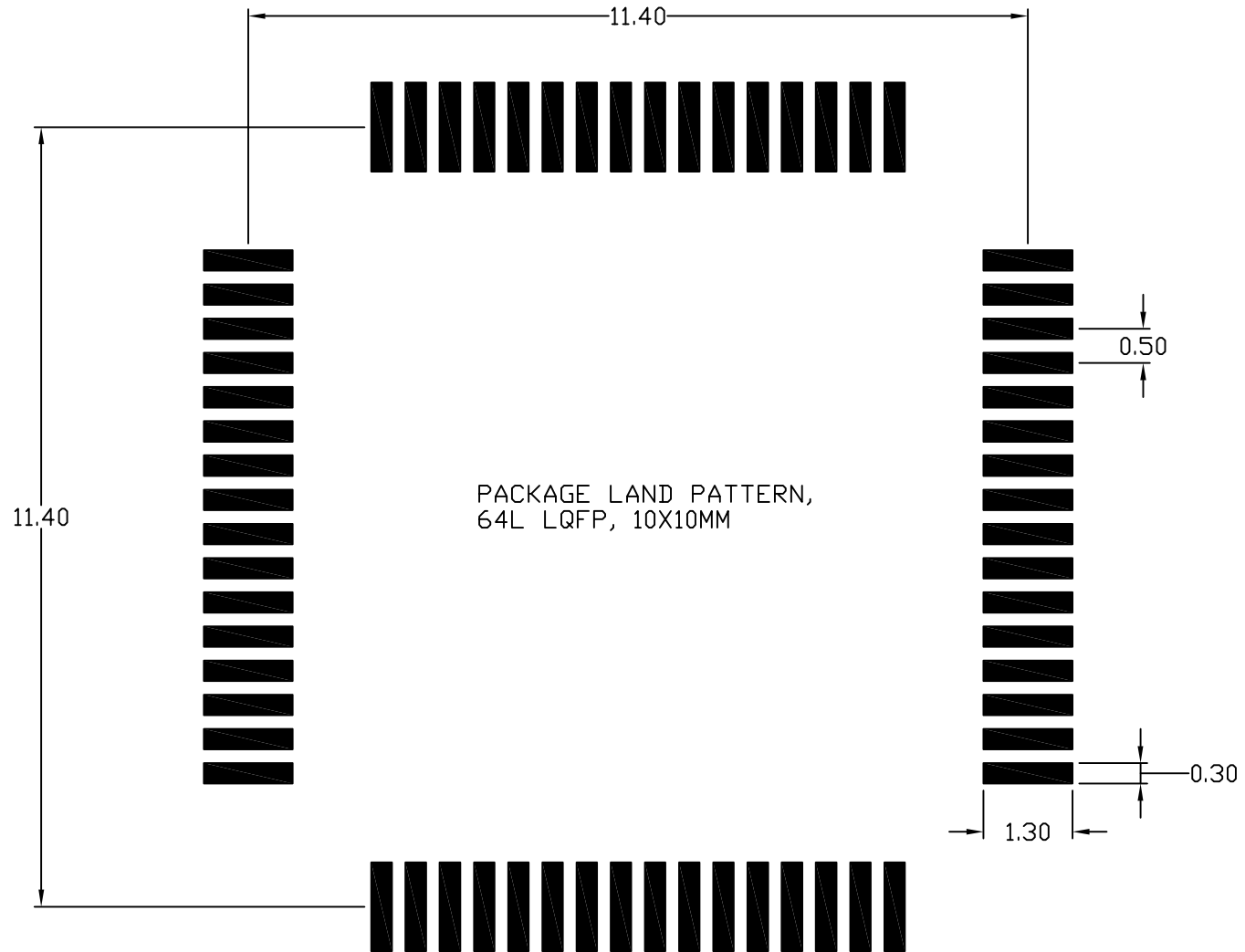

NOTES:

1. ALL DIMENSIONS IN MM
2. LAND PATTERN COMPLIES TO: IPC7351A.
3. TOLERANCE: +/- 0.02 MM.