



73D2248A/2348A MNP5, V.42bis Datacom Modem Device Set

April 2000

DESCRIPTION

The 73D2248A/2348A Device Sets consists of two CMOS integrated circuits which provide the data pump and protocol functions required to implement a high performance 2400 bit/s modem with error control and data compression. The 73D2248A basic modem function is provided by the 73K224L modem chip and is compatible with CCITT V.21, V.22, V.22bis and Bell 103 and 212A protocols. The error control functions are provided by modular software running in the 73M2910 controller. Modules are available for MNP4, and V.42. Compression software modules can be added to the controller; MNP5 and V.42bis are available. Provisions for customization of the command set are provided, forming the basis for an international modem.

The 73D2348 differs from the 73D2248A in that it uses the 73K324L instead of the 73K224L for the data pump. The 73K324L replaces the Bell 103, 300 bps (bit/s) FSK mode of operation, with the CCITT V.23, 1200 bps (bit/s) FSK mode. The software is also modified to support V.23. The two products are otherwise identical.

FEATURES

- Combines modem and protocol controller
- Supports 0 - 300, 1200 and 2400 bit/s with both sync and async modes
- Modular software design allows customization
- Modem protocols:
 - Bell 103 (73K224L), 212A
 - CCITT V.21, V.22, V.22bis, V.23 (73K324L)
 - Error control/compression protocols Available: MNP4, MNP5, CCITT V.42, V.42bis
- Supports non-volatile memory to store user configurations and phone numbers
- CMOS design for low power consumption

MNP5, V.42bis Datacom Modem Device Set

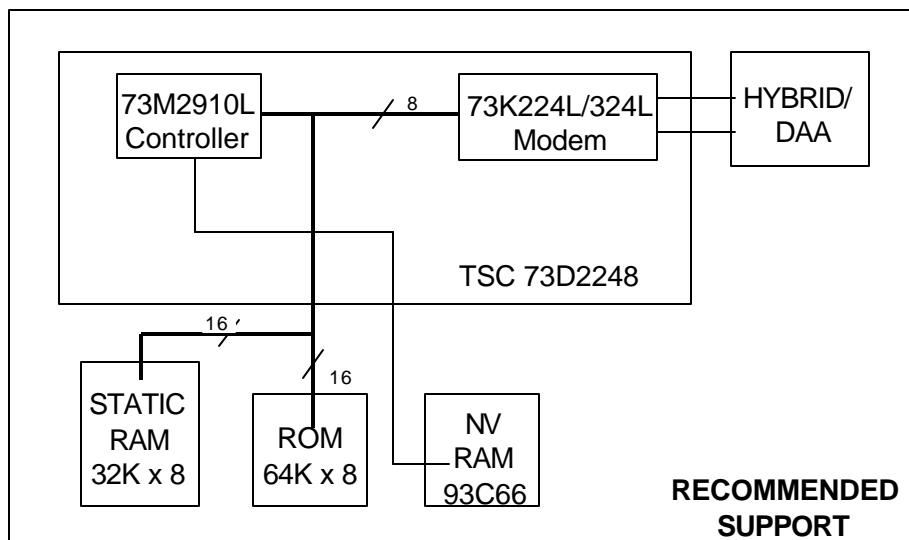

73D2248A/2348A

MNP5, V.42bis Datacom

Modem Device Set

FUNCTIONAL DESCRIPTION

The 73D2248A/2348A device set forms the basis for an international modem design incorporating the most advanced error control and compression algorithms. The set consists of two chips, the 73K224L (73K324L) modem and the 73M2910 controller. Customization of the controller is one of the features of this device set; software modules allow the modem vendor to provide a range of features from a standard hardware platform.

The 73K224L (73K324L) provides the QAM, PSK and FSK modulator and demodulator functions, call progress and handshake tone monitors, test modes and a tone generator capable of producing DTMF, answer and CCITT guardtones. This single-chip modem supports the V.22bis, V.22, V.21 and Bell 103/CCITT V.23/212A operating protocols in both sync and async modes. Low level functions of the controller provide for automatic detection of DTE speed, auto-dial, auto-answer, handshake with fallback and call progress detection.

The 73M2910 controller handles both the low level modem functions as well as protocol negotiation and protocol operation. Software modules can be chosen to provide the desired protocols for product customization and differentiation. In addition, the "AT" command set source code will be available for those desiring to provide unique or country dependent features.

Basic capabilities of the modem are those found in the 73K224L (73K324L) single-chip modem and are listed in the separate 73K224L (73K324L) data sheet.

AUTOMATIC HANDSHAKE

The 73D2248A/2348A will automatically perform a complete handshake with a called or calling modem and enter the data transfer mode. After the link between the two modems has been established, the modems may remain in the normal data mode or negotiate a link which has error control and data compression. Commands are provided to inform the modem which action is appropriate.

TEST MODES

The 73D2248A/2348A device set has provisions for three test modes: analog loopback, digital loopback and remote digital loopback. Analog loopback allows data to be sent into the local modem, have it modulated and then demodulated and returned to the local terminal. Digital loopback requires the cooperation of the user at the remote end and allows data to be sent to the remote modem, demodulated, then remodulated and returned to the local end. Remote digital loopback allows the same capability, without the need for a remote operator; signals are sent to the remote modem which perform the switching task that a remote operator would have done.

AT COMMAND INTERPRETER

The 73D2248A/2348A includes an AT Command Interpreter which is a superset of the Hayes 2400 Smartmodem™ command set. Common application software will be able to control the modem through this interpreter. Additional commands have been added to provide for control of the MNP and CCITT V.42 modes.

NON-VOLATILE MEMORY

A serial NVRAM provides 256 bytes of storage for configuration information and telephone numbers.

73D2248A/2348A

MNP5, V.42bis Datacom Modem Device Set

PROTOCOLS

Microcom Networking Protocol (MNP)

MNP4 is a protocol offering error control while MNP5 offers data compression. Data to be transmitted is broken into blocks of varying sizes, depending on line conditions, and sent to the remote modem along with a 16-bit Cyclic Redundancy Check (CRC) word. If the algorithm used to derive the CRC word at the transmitter does not produce an identical word when exercised on the received data, a line error is assumed, and the block is repeated. Data compression is obtained by transmitting a short set of characters for a longer redundant set. At the receiver, the short string is replaced with the longer string that it represented, and the data stream is returned to its original state.

CCITT V.42 AND V.42BIS

The CCITT has ratified a set of protocols which operate in a manner similar to MNP. MNP4 corresponds to V.42 while MNP5 corresponds with V.42bis. Greater efficiency is offered, but the tradeoff is a larger memory space requirement. MNP5 requires an 8K buffer, while V.42bis requires 32K. Data files which show compression ratios approaching 2:1 with MNP5 may show ratios of nearly 4:1 with V.42bis.

ADDITIONAL INFORMATION

The TDK Semiconductor Corporation 73D2248/2348 Design Manual defines the AT commands. Please contact your local TDK Semiconductor Corporation's sales office for a copy of the TDK Semiconductor Corporation's Protocol Design Manual.

73D2248A/2348A

MNP5, V.42bis Datacom

Modem Device Set

AT COMMAND SUMMARY

| Command | Description | Command | Description |
|-----------|---|----------------|---|
| AT | command prefix - precedes command line | X4 | <i>enable features represented by result codes 0-7, 10-12</i> |
| <CR> | carriage return character - terminates command line | Y0 | disable long space disconnect |
| A | go into answer mode; attempt to go to on-line state | Y1 | enable long space disconnect |
| A/ | re-execute previous command line; not preceded by AT nor followed by <CR> | Z0 | reset modem |
| B0 | select CCITT V.22 and V.21 standards for 1200 and 300 bit/s communications | &C0 | <i>assume data carrier always present</i> |
| B1 | <i>select Bell 212A and Bell 103 standards for 1200 and 300 bit/s communications</i> | &C1 | track presence of data carrier |
| D | dial number that follows; attempt to go to on-line state, originate mode | &D0 | <i>ignore DTR signal</i> |
| DS=n | dial stored number in location "n" (0-3) | &D1 | assume command state when an on-to-off transition of DTR occurs |
| E0 | Disable character echo in command state | &D2 | hang up and assume command state when an on-to-off transition of DTR occurs |
| E1 | <i>Enable character echo in command state</i> | &D3 | reset when an on-to-off transition of DTR occurs |
| H0 | go on hook (hang up) | &F | recall factory settings as active configuration |
| H1 | go off hook; operate auxiliary relay | &G0 | <i>no guard tone</i> |
| I0 | request product identification code | &G1 | 550 Hz guard tone |
| I1 | perform checksum on firmware ROM; return checksum | &G2 | 1800 Hz guard tone |
| I2 | perform checksum on firmware ROM; returns OK or ERROR result codes | &K | flow control method |
| L0 or L1 | low speaker volume | &M0 | <i>asynchronous mode</i> |
| L2 | <i>medium speaker volume</i> | &M1 | synchronous mode 1 |
| L3 | high speaker volume | &M2 | synchronous mode 2 |
| M0 | speaker off | &M3 | synchronous mode 3 |
| M1 | <i>speaker on until carrier detected</i> | &Q5 | error control mode |
| M2 | speaker always on | &Q6 | automatic speed buffering (ASB) |
| M3 | speaker on until carrier detected, except during dialing | &T0 | terminate test in progress |
| O0 | go to on-line state | &T1 | initiate local analog loopback |
| O1 | go to on-line state and initiate equalizer retrain at 2400 bit/s | &T3 | initiate local digital loopback |
| Q0 | <i>modem returns result codes</i> | &T4 | <i>grant request from remote modem for RDL</i> |
| Q1 | modem does not return result codes | &T5 | deny request from remote modem for RDL |
| Sr | set pointer to register "r" | &T6 | initiate remote digital loopback |
| Sr=n | set register "r" to value "n" | &T7 | initiate remote digital loopback with self test |
| Sr? | display value stored in register "r" | &T8 | initiate local analog loopback with self test |
| V0 | display result codes in numeric form | &V | view active configuration, user profiles, and stored numbers |
| V1 | <i>display result codes in verbose form (as words)</i> | &W0 | save storable parameters of active configuration |
| W0 | <i>negotiation progress result codes not returned</i> | &X0 | <i>modem provides transmit clock signal</i> |
| W1 | negotiation progress result codes returned | &X1 | data terminal provides transmit clock signal |
| X0 | enable features represented by result codes 0-4 | &X2 | receive carrier provides transmit clock signal |
| X1 | enable features represented by result codes 0-5, 10-12 | &Zn=x | store phone number "x" in location "n" (0-3) |
| X2 | enable features represented by result codes 0-6, 10-12 | | |
| X3 | enable features represented by result codes 0-5, 7, 10-12 | | |

73D2248A/2348A MNP5, V.42bis Datacom Modem Device Set

Dial string arguments:

, = delay @ = silent answer ! = flash
 ; = return to command s = dial stored number W = wait for tone R = reverse mode

If the NOVRAM has not been initialized it may be necessary to power down/power up and type *AT&F&W<cr>* to properly initialize modem state.

TABLE 1: Result Codes

| Xn | VERBOSE/NUMERIC RESULT CODES |
|----|---|
| X0 | OK/0, CONNECT/1, RING/2, NO CARRIER/3, ERROR/4 |
| X1 | All functions of X0 + CONNECT (RATE)/1 = 300, 5 = 1200, 10 = 2400 |
| X2 | All functions of X1 + NO DIAL TONE/6 |
| X3 | All functions of X1 + BUSY/7 |
| X4 | All functions of X3 + NO DIAL TONE/6, NO ANSWER/8 |

TABLE 2 S Registers Supported

| Sn | FUNCTION | UNITS | DEFAULT |
|-------------------|---------------------|---------------------------------|------------------|
| S0 ¹ | Answer on ring | No. of rings on which to answer | 000 ² |
| S1 | Ring counter | No. of rings accumulated | 000 |
| S2 | Escape code | ASCII CHR Decimal 0-127 | 043 |
| S3 | Carriage return | ASCII CHR Decimal 0-127 | 013 |
| S4 | Line feed | ASCII CHR Decimal 0-127 | 010 |
| S5 | Back space | ASCII CHR | 008 |
| S6 | Wait for dial tone | Seconds | 002 |
| S7 | Wait for carrier | Seconds | 030 |
| S8 | Pause time | Seconds | 002 |
| S9 | Carrier valid | 100 milliseconds (0.1 sec) | 006 |
| S10 | Carrier drop out | 100 milliseconds (0.1 sec) | 014 |
| S11 | DTMF tone duration | 1 millisecond (0.001 sec) | 070 |
| S12 | Escape guard time | 20 milliseconds (0.05 sec) | 050 |
| S13 | Unused | | N/A |
| *S14 ¹ | Bit mapped register | Decimal 0-255 | 170 |
| S15 | Unused | | N/A |

¹ Stored in NVRAM with &W command.

² Modem will not answer until value is changed to 1 or greater.

73D2248A/2348A

MNP5, V.42bis Datacom

Modem Device Set

TABLE 2 S Registers Supported (continued)

| Sn | FUNCTION | UNITS | DEFAULT |
|-------------------|--------------------------------|----------------------------|---------|
| S16 | Test register | Decimal # | 000 |
| S17 | Special test register | Decimal 0-255 | 096 |
| S18 | Test timer | Decimal 0-255 | 000 |
| S19 | Unused | | N/A |
| S20 | Unused | | N/A |
| *S21 ¹ | Bitmapped register | Decimal 0-255 | 000 |
| *S22 ¹ | Bitmapped register | Decimal 0-255 | 118 |
| *S23 ¹ | Bitmapped register | Decimal 0-255 | 007 |
| S24 | Unused | | N/A |
| S25 ¹ | DTR delay | 10 milliseconds (0.01 sec) | 005 |
| S26 ¹ | CTS delay | 10 milliseconds (0.01 sec) | 001 |
| *S27 ¹ | Bitmapped register | Decimal 0-255 | 064 |
| S36 | Negotiation failure treatment | | 5 |
| S37 | Desired modem line speed | Decimal 0-9 | 000 |
| S38 | Hang-up timeout | | 20 |
| S39 | Current flow control setting | | 3 |
| S43 | Current DCE speed | | 0 |
| S46 | Protocol/Compression selection | | 2 |
| S48 | Feature negotiation action | | 7 |
| S49 | ASB Buffer low limit | 1-249 | 8 |
| S50 | ASB Buffer high limit | 2-250 | 16 |
| S82 | Break select register | | 128 |
| S95 | Extended result code bit map | | 0 |

*The bitmapped register functions are equivalent to normal "AT" command modem registers.

¹ Stored in NVRAM with &W command

73D2248A/2348A MNP5, V.42bis Datacom Modem Device Set

MECHANICAL SPECIFICATIONS

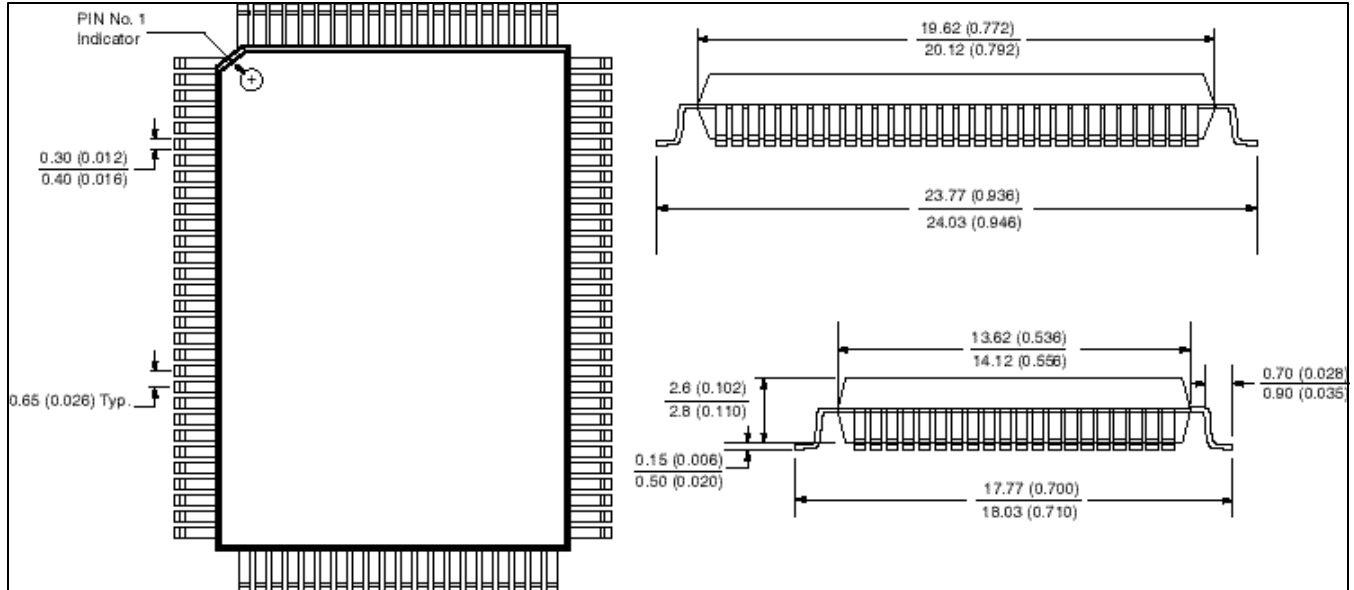

28-Pin PLCC

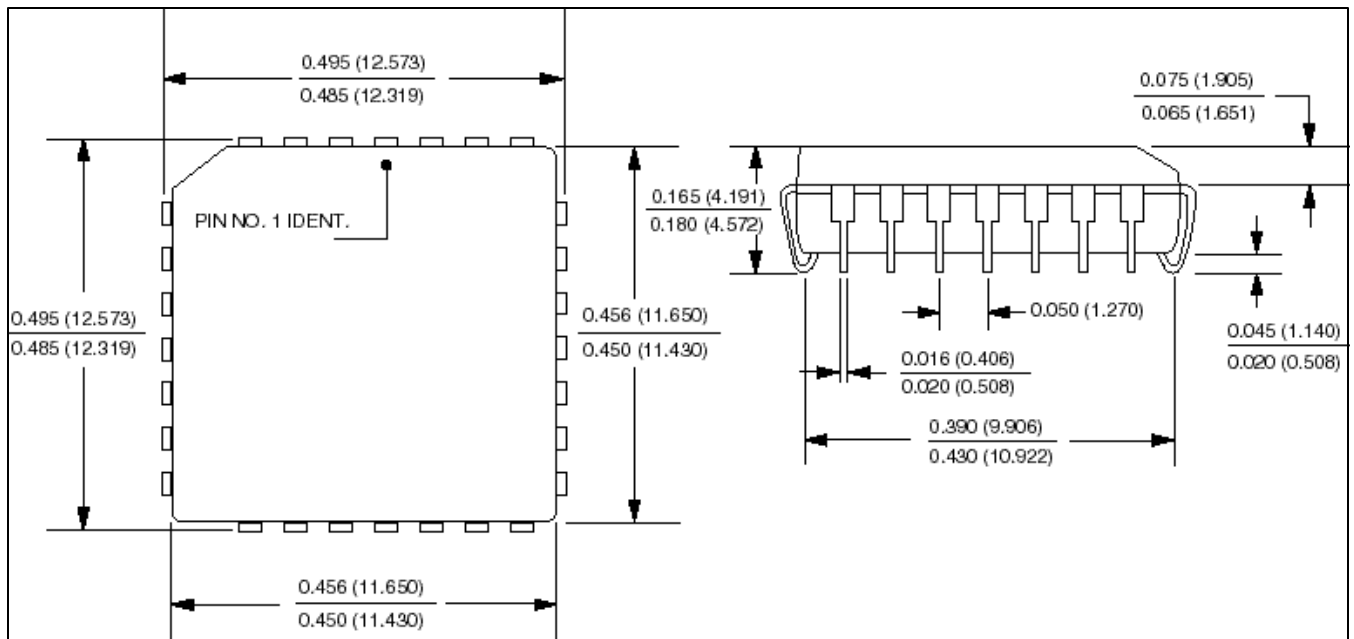

73D2248A/2348A

MNP5, V.42bis Datacom

Modem Device Set

PACKAGE PIN DESIGNATIONS

(Top View)

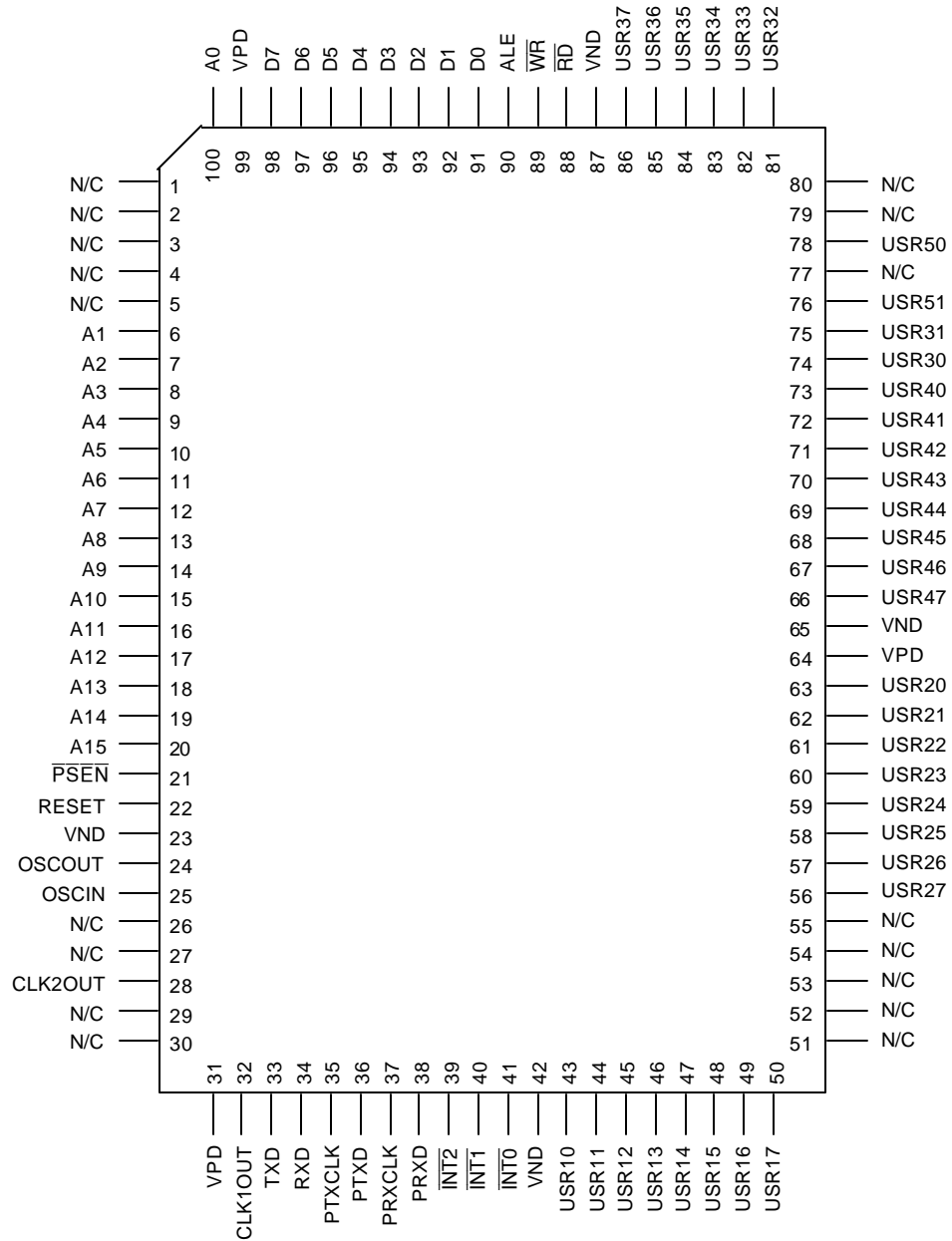

73M2910L-IG
Controller
100-Lead QFP

73D2248A/2348A MNP5, V.42bis Datacom Modem Device Set

PACKAGE PIN DESIGNATIONS (continued) (Top View)

CAUTION: Use handling procedures necessary for a static sensitive component.

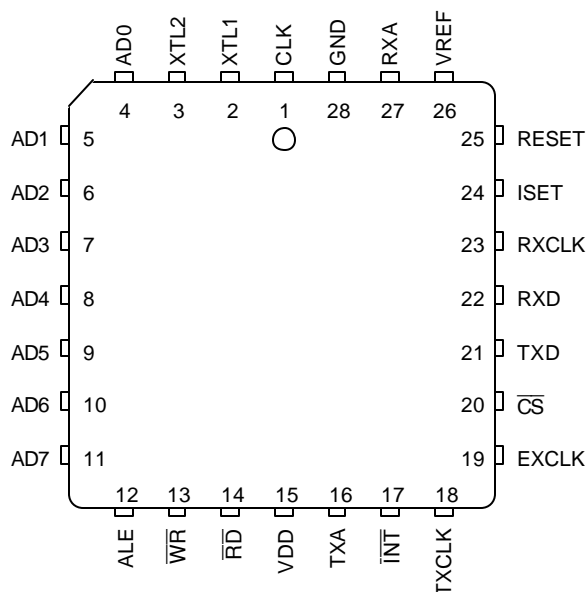

**73K224L-28IH or 73K324L-28IH
Single Chip Modem
28-Pin PLCC**

ORDERING INFORMATION

| PART DESCRIPTION | ORDER NUMBER | PACKAGING MARK |
|--|--------------|--------------------------|
| 73D2248 Surface Mount Packages 73K224L-IH/73M2910L-IG | 73D2248 | 73K224L-28IH/73M2910L-IG |
| 73D2348 Surface Mount Packages 73K324L-IH/73M2910L-IG | 73D2348 | 73K324L-28IH/73M2910L-IG |

No responsibility is assumed by TDK Semiconductor Corporation for use of this product nor for any infringements of patents and trademarks or other rights of third parties resulting from its use. No license is granted under any patents, patent rights or trademarks of TDK Semiconductor Corporation and the company reserves the right to make changes in specifications at any time without notice. Accordingly, the reader is cautioned to verify that you are referencing the most current data sheet before placing orders. To do so, see our web site at <http://www.tsc.tdk.com> or contact your local TDK Semiconductor representative.

Copyright Notice:

The software contained within certain components of the 73D2248A/2348A is copyright protected and may only be used in conjunction with the 73D2248A/2348A product as supplied by TDK Semiconductor Corporation. No license to reproduce this software is granted or implied. This material may not be reproduced in any form without the express written permission of TDK Semiconductor Corporation. ©Copyright 1992. All rights reserved.

TDK Semiconductor Corp., 2642 Michelle Dr., Tustin, CA 92780, (714) 508-8800, FAX (714) 508-8877, <http://www.tsc.tdk.com>

Protected by the following patents: (4,777,453)
(4,789,995) (4,870,370) (4,847,868) (4,866,739)
©1992 TDK Semiconductor Corporation

04/24/00- rev. D