

DESCRIPTION

The SSI 73M550 is a Universal Asynchronous Receiver/Transmitter (UART) with receive and transmit FIFO buffers. The 16-byte FIFO registers are active during the FIFO mode, allowing the UART to reduce CPU overhead and accommodate Direct Memory Access (DMA) transfers. This mode is supported by interrupt functions and selectable interrupt trigger levels in both the RCVR and TXMR FIFO.

The 73M550 is functionally identical to the SSI 73M450L in the CHARACTER mode. Pins 24 (CSOUT) and 29 (NC) of the 73M450L have been replaced by TXRDY and RXRDY, respectively, on the 73M550. The chip is automatically put into the CHARACTER mode upon power-up, and subsequent mode changes are accomplished via software control.

The 73M1550 and 73M2550 are 28-pin versions of the 73M550. The difference between these versions is that 73M2550 adds a μ PRST pin at the expense of the XOUT pin. See Figure 17 on page 32 for detail. These products require a single 5V supply.

FEATURES

- 16 bytes of receive and transmit FIFO buffering available in FIFO mode reduces CPU overhead
- Supports DMA transfers with TXRDY and RXRDY pins
- High-speed timing for zero wait-state operation is compatible with PCMCIA interface
- Oscillator disable allows a static low-power state
- Bit-programmable high impedance state of INTRPT pin
- High drive current for directly driving large loads
- Full double buffering
- Independent control transmit, receive, line status and data set interrupts
- Contains modem control functions including CTS, RTS, DSR, DTR, RI and DCD
- Available in 40-pin DIP, 44-and 28-pin PLCC, 48-lead TQFP (73M550) and 52-lead QFP (73M2550) packages
- CMOS design for low-power operation

BLOCK DIAGRAM

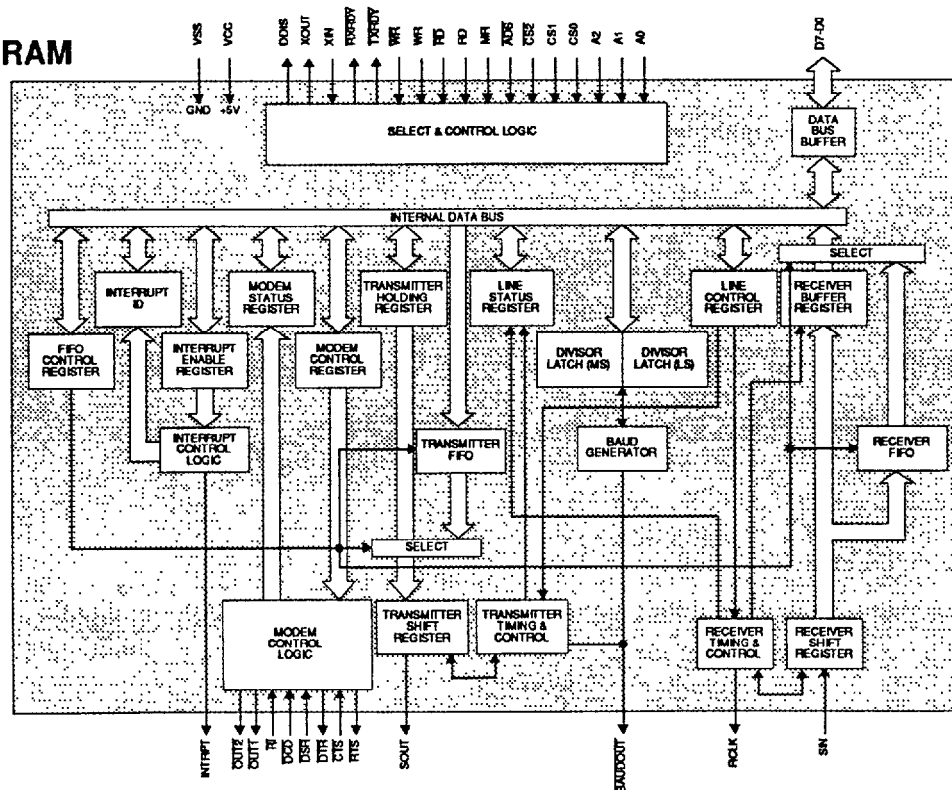

SSI 73M550

SSI 73M1550/2550

UART with FIFOs

PIN DESCRIPTION

BUS INTERFACE

NAME	TYPE	DESCRIPTION
\overline{ADS}	I	Address Strobe: The rising edge of this signal is used for latching the Register Address and Chip Select inputs, thus facilitating interface to a multiplexed Address/Data bus. \overline{ADS} is also required when register address signals (A2, A1, A0) are not stable for the duration of the read or write cycle. If not required, \overline{ADS} should be tied permanently low.
CS0, CS1, $\overline{CS2}$	I	Chip Select: The UART is selected when CS0 and CS1 are high and $\overline{CS2}$ is low. Chip selection is complete when the decoded chip select signal is latched with the rising edge of an active (low) \overline{ADS} input. This enables communication between the UART and the CPU. If \overline{ADS} is permanently low, then chip select should be stabilized for the duration of the tCSW parameter.
A0-A2	I	Register Select Address: These pins determine which of the UART registers is being selected during a read or write on the UART Data Bus. The contents of the DLAB bit in the UART's Line Control Register (see Table 1) also controls which register is referenced.
RD, \overline{RD}	I	Read Strobe: A request to read status information or data from a selected register may be made by pulling RD high or \overline{RD} low while the chip is selected. Since only one input is required for a read, tie either RD permanently low or \overline{RD} permanently high if not used.
WR, \overline{WR}	I	Write Strobe: A request to write control words or data into a selected register may be made by pulling WR high or \overline{WR} low while the chip is selected. Since only one input is required for a write, tie either WR permanently low or \overline{WR} permanently high if not used.
D0-D7	I/O	UART Data Bus (three-state): This bus provides bi-directional communications between the UART and the CPU; data control words and status information are transferred via this bus.
\overline{TXRDY}	I/O	Transmitter Ready Signal for DMA Transfer: Remains low as long as XMIT FIFO is not completely full. In FIFO mode, DMA transfer modes 0 and 1 are allowed. In the character mode, only DMA transfer mode 0 is allowed. DMA mode 0 supports single DMA transfer mode between CPU bus cycles. DMA mode 1 supports multiple DMA transfers until the XMIT FIFO has been filled.
\overline{RXRDY}	O	Receiver Ready Signal for DMA Transfer: Remains low until RCVR FIFO has been emptied. In FIFO mode DMA transfer modes 0 and 1 are allowed. In the character mode only DMA mode 0 is allowed. DMA mode 0 supports single DMA transfer made between CPU bus cycles. DMA mode 1 supports multiple DMA transfers until the RCVR FIFO has been emptied.
DDIS	O	Driver Disable: Goes low when the CPU is reading data from the UART. A high-level DDIS output can be used to disable an external transceiver (if used between the CPU and UART on the D0-D7 Data Bus) at all times, except when the CPU is reading data.

SSI 73M550

SSI 73M1550/2550

UART with FIFOs

BUS INTERFACE (Continued)

NAME	TYPE	DESCRIPTION
INTRPT	O	Interrupt: Goes high whenever any one of the following interrupt types has an active high condition and is enabled via the IER: Receiver Error Flag, Received Data Available; Timeout (FIFO mode only); Transmitter Holding Register Empty and Modem Status. The INTRPT signal is reset low upon the appropriate interrupt service or a Master Reset operation.

DATA I/O

SIN	I	Serial Input: Input for serial data from the communications link (peripheral device, modem or data set).
SOUT	O	Serial Output: Output for serial data to the communications link (peripheral device, modem or data set). This signal is set high upon a Master Reset.

MODEM CONTROL

$\overline{\text{RTS}}$	O	Request To Send: This output is programmed by $\overline{\text{RTS}}$ bit (D1) of the Modem Control Register and represents the compliment of that bit. It is used in modem handshaking to signify that the UART has data to transmit. This signal is set high upon Master Reset or during loop mode operation.
$\overline{\text{CTS}}$	I	Clear To Send: A modem status input whose condition corresponds to the complement of the CTS bit (D4) of the Modem Status Register. When $\overline{\text{CTS}}$ is low, it indicates that communications have been established and that data may be transmitted.
$\overline{\text{DTR}}$	O	Data Terminal Ready: This output is programmed by DTR bit (D0) of the Modem Control Register, and represents the compliment of that bit. It is used in modem handshaking to signify that the UART is available to communicate. This signal is set high upon Master Reset or during loop mode operation.
$\overline{\text{DSR}}$	I	Data Set Ready: A modem status input whose condition is complimented and reflected in the DSR bit (D5) of the Modem Status Register. When $\overline{\text{DSR}}$ is low, it indicates that the modem is ready to establish communications.
$\overline{\text{DCD}}$	I	Data Carrier Detect: A modem status input whose condition is complemented and reflected in the DCD bit (D7) of the Modem Status Register. When $\overline{\text{DCD}}$ is low, it indicates that the modem is receiving a carrier.
$\overline{\text{RI}}$	I	Ring Indicator: A modem status input whose condition is complimented and reflected in the RI bit (D6) of the Modem Status Register. When $\overline{\text{RI}}$ is low, it indicates that a telephone ringing signal is being received.
$\overline{\text{OUT1}}$ $\overline{\text{OUT2}}$	O O	Output 1, 2: User designated outputs that can be set to an active low by setting bit 2 ($\overline{\text{OUT1}}$) or bit 3 ($\overline{\text{OUT2}}$) of the Modem Control Register high. These output signals are set high upon Master Reset or during loop mode operation.

SSI 73M550

SSI 73M1550/2550

UART with FIFOs

GENERAL & CLOCKS

NAME	TYPE	DESCRIPTION
VCC	I	+5V Supply, $\pm 10\%$: Bypass with 0.1 μF capacitor to VSS.
VSS	I	System Ground
MR	I	Master Reset: When high, this input clears all UART control logic and registers, except for the Receiver Buffer, Transmitter Holding and Divisor Latches; also, the state of output signals SOUT, INTRPT, OUT1, OUT2, RTS and DTR are affected by an active MR input. This input is buffered with a TTL-compatible Schmitt Trigger. See Table 2.
XIN, XOUT	I/O	External System Clock I/O: These two pins connect the main timing reference (crystal or signal clock) to the UART. Additionally, XIN may be driven by an external clock source.
RCLK	I	Receiver Clock: This input is the 16X baud rate clock for the receiver section of the chip.
BAUDOUT	O	Baud Generator Output: 16X clock signal for the transmitter section of the UART. The clock is equal to the main reference oscillator frequency divided by the specified divisor in the Baud Generator Divisor Latches. May also be used for the receiver section by tying this output to the RCLK input of the chip.
N/C	-	No Connection: These pins have no internal connection and may be left floating.

28-PIN VERSION, SPECIAL PINS

INTRPT	O	Interrupt: In the 28-pin versions of this chip, the INTRPT pin can be forced into a high impedance state by resetting to 0 the OUT2 bit (D3) of the Modem Control Register. INTRPT pin operation is enabled by setting the OUT2 bit to 1.
XIN, XOUT	I/O	External System Clock: The XOUT pin is not available on the 73M2550 and therefore must be driven by an external clock connected to the XIN pin.
μPRST	O	Microprocessor Reset: This output signal is used to provide a hardware reset to a local controller. This pin becomes active high when the MR pin is pulled high or the OUT1 bit (D2) of the Modem Control Register is set to 1. The μPRST function is available only on the 73M2550.

SSI 73M550

SSI 73M1550/2550

UART with FIFOs

TABLE 1: Control Register Address Table

DLAB	A2	A1	A0	REGISTER
0	0	0	0	Receiver Buffer (read), Transmitter Holding Register (write)
0	0	0	1	Interrupt Enable
X	0	1	0	Interrupt Identification (read only)
X	0	1	0	FIFO Control (write)
X	0	1	1	Line Control
X	1	0	0	Modem Control
X	1	0	1	Line Status
X	1	1	0	Modem Status
X	1	1	1	Scratch
1	0	0	0	Divisor Latch (least significant byte)
1	0	0	1	Divisor Latch (most significant byte)

TABLE 2: UART Reset Functions

REGISTER/SIGNAL	RESET CONTROL	RESET STATE
Interrupt Enable Register	Master Reset	All bits low (0-3 & 5 forced and 4, 6 & 7 permanent)
Interrupt Identification Register	Master Reset	Bit 0 is high; bits 1, 2, 3, 6 & 7 are low; bits 4 & 5 are permanently low
Line Control Register	Master Reset	All bits low
Modem Control Register	Master Reset	All bits low (bits 5, 6 & 7 permanent)
Line Status Register	Master Reset	All bits low, except bits 5 & 6 are high
Modem Status Register	Master Reset	Bits 0-3 are low; bits 4-7 = input signal
SOUT	Master Reset	High
INTRPT (RCVR Errs)	Read LSR/MR	Low
INTRPT (RCVR Data Ready)	Read RBR/MR	Low
INTRPT (THRE)	Read IIR/Write THR/MR	Low
INTRPT (Modem Status Changes)	Read MSR/MR	Low
$\overline{\text{OUT2}}$	Master Reset	High
$\overline{\text{RTS}}$	Master Reset	High
$\overline{\text{DTR}}$	Master Reset	High
$\overline{\text{OUT1}}$	Master Reset	High
FIFO Control Register	Master Reset	All bits low
RCVR FIFO	MR/FCR1 and FCR0/ Δ FCR0	All bits low
XMIT FIFO	MR/FCR2 and FCR0/ Δ FCR0	All bits low

SSI 73M550

SSI 73M1550/2550

UART with FIFOs

CONTROL REGISTER OVERVIEW

REGISTER		REGISTER ADDRESS (A2-A0) & DLAB	DATA BIT NUMBER							
			D7	D6	D5	D4	D3	D2	D1	D0
RECEIVER BUFFER REGISTER (READ ONLY)	RBR	000 DLAB=0	BIT 7 (MSB)	BIT 6	BIT 5	BIT 4	BIT 3	BIT 2	BIT 1	BIT 0 (LSB)
TRANSMIT HOLDING REGISTER (WRITE ONLY)	THR	000 DLAB=0	BIT 7 (MSB)	BIT 6	BIT 5	BIT 4	BIT 3	BIT 2	BIT 1	BIT 0 (LSB)
INTERRUPT ENABLE REGISTER	IER	001 DLAB=0	0	0	ENABLE SSI MODE (NOTE 1)	0	ENABLE MODEM STATUS INTERRUPT	ENABLE REC. LINE STATUS INTERRUPT	ENABLE THR EMPTY INTERRUPT	ENABLE REC. DATA AVAILABLE INTERRUPT
INTERRUPT ID REGISTER (READ ONLY)	IIR	010 DLAB=X	FIFOs ENABLED (NOTE 1)	FIFOs ENABLED (NOTE 1)	SSI MODE RXRDY FOR DMA	SSI MODE TXRDY FOR DMA	INTERRUPT ID BIT 2 (NOTE 1)	INTERRUPT ID BIT 1	INTERRUPT ID BIT 0	0* IF INTERRUPT PENDING
FIFO CONTROL REGISTER (WRITE ONLY)	FCR	010 DLAB=X	RCVR TRIGGER (MSB)	RCVR TRIGGER (LSB)	SSI MODE XMIT TRIGGER (MSB)	SSI MODE XMIT TRIGGER (LSB)	DMA MODE SELECT	XMIT FIFO RESET	RCVR FIFO RESET	FIFO ENABLE
LINE CONTROL REGISTER	LCR	011 DLAB=X	DIVISOR LATCH ACCESS (DLAB)	SET BREAK	STICK PARITY	EVEN PARITY SELECT (EPS)	PARITY ENABLE (PEN)	NUMBER OF STOP BITS (STB)	WORD LENGTH SELECT 1 (WLS1)	WORD LENGTH SELECT 0 (WLS0)
MODEM CONTROL REGISTER	MCR	100 DLAB=X	SSI MODE OSC OFF	0	0	LOOP	OUT 2	OUT 1	REQUEST TO SEND (RTS)	DATA TERMINAL READY (DTR)
LINE STATUS REGISTER	LSR	101 DLAB=X	ERROR IN RCVR FIFO (NOTE 1)	TRANSMITTER EMPTY (TEMT)	TRANSMIT HOLDING REGISTER EMPTY (THRE)	BREAK INTERRUPT (BI)	FRAMING ERROR (FE)	PARITY ERROR (PE)	OVERRUN ERROR (OE)	DATA READY (DR)
MODEM STATUS REGISTER (READ ONLY)	MSR	110 DLAB=X	DATA CARRIER DETECT (DCD)	RING INDICATOR (RI)	DATA SET READY (DSR)	CLEAR TO SEND (CTS)	DELTA DATA CARR. DETECT (DDCD)	TRAILING EDGE RING INDICATOR (TERI)	DELTA DATA SET READY (DDSR)	DELTA CLEAR TO SEND (DCTS)
SCRATCH REGISTER	SCR	111 DLAB=X	BIT 7	BIT 6	BIT 5	BIT 4	BIT 3	BIT 2	BIT 1	BIT 0
DIVISOR LATCH (MS)	DLL	000 DLAB=1	BIT 7	BIT 6	BIT 5	BIT 4	BIT 3	BIT 2	BIT 1	BIT 0
DIVISOR LATCH (MS)	DLM	001 DLAB=1	BIT 15	BIT 14	BIT 13	BIT 12	BIT 11	BIT 10	BIT 9	BIT 8

NOTE 1: THESE BITS ARE RESET TO 0 IN THE 73M450 MODE (Character Mode)

REGISTER BIT DESCRIPTIONS

RECEIVER BUFFER REGISTER (RBR) (READ ONLY)

UART ADDRESS: A2 - A0 = 000, DLAB = 0

This read only register contains the parallel received data with start, stop, and parity bits (if any) removed. The high order bits for less than 8 data bits/character will be set to 0.

TRANSMIT HOLDING REGISTER (THR) (WRITE ONLY)

UART ADDRESS: A2 - A0 = 000, DLAB = 0

This write only register contains the parallel data to be transmitted. The data is sent LSB first with start, stop, and parity bits (if any) added to the serial bit stream as the data is transferred.

SSI 73M550

SSI 73M1550/2550

UART with FIFOs

INTERRUPT ENABLE REGISTER (IER)
UART ADDRESS: A2 - A0 = 001, DLAB = 0

This 8-bit register enables the five types of interrupts of the UART to separately activate the chip Interrupt (INTRPT) output signal. It is possible to totally disable the interrupt system by resetting bits 0 through 3 of the Interrupt Enable Register. Similarly, by setting the appropriate bits of this register to a logic 1, selected interrupts can be enabled. Disabling the interrupt system inhibits the Interrupt Identification Register and the active (high) INTRPT output from the chip. All other system functions operate in their normal manner, including the setting of the Line Status and Modem Status Registers.

The chip's SSI mode can be activated by setting bit D5. Once in the SSI mode, the chip can be placed in a power shut-down state by setting bit D7 in the Modem Control Register.

BIT	NAME	COND	DESCRIPTION
D0	Received Data	1	When set to logic 1 this bit enables the Received Data Available Interrupt, and timeout interrupts in FIFO mode.
D1	Transmitter Holding Register Empty	1	When set to logic 1 this bit enables the Transmitter Holding Register Empty Interrupt.
D2	Receiver Line Status Interrupt	1	When set to logic 1 this bit enables the Receiver Line Status Interrupt.
D3	Modem Status	1	When set to logic 1 this bit enables the Modem Status Interrupt.
D4	Not Used	0	This bit are is always logic 0.
D5	SSI Mode	1	When set to logic 1, this bit enables the SSI Mode. In the SSI Mode the oscillator can be turned off via bit D7 in the Modem Control Register, and the XMIT THRE interrupt trigger set via bits D4 & D5 of the FIFO Control Register.
D6-D7	Not used	0	These two bits are always logic 0.

SSI 73M550

SSI 73M1550/2550

UART with FIFOs

INTERRUPT ID REGISTER (IIR) (READ ONLY)

UART ADDRESS: A2 - A0 = 010

The IIR register gives prioritized information as to the status of interrupt conditions and also allows for DMA transfer operations in a polled FIFO manner under the SSI mode. When accessed, the IIR freezes the highest priority interrupt pending and no other interrupts are acknowledged until the particular interrupt is serviced by the CPU. The order of interrupt priorities is shown in the table below.

BIT	NAME	COND	DESCRIPTION
D0	Interrupt Pending	0	This bit can be used in either a prioritized interrupt or polled environment to indicate whether an interrupt is pending. When bit 0 is a logic 0, an interrupt is pending and the IIR contents may be used as a pointer to the appropriate interrupt service routine.
		1	When bit 0 is a logic 1, no interrupt is pending.
D1, D2, D3	Interrupt ID bits 0, 1, 2	See table Page 10	These three bits of the IIR are used to identify the highest priority interrupt pending as indicated in the following table. Bit D3 is reset to 0 when FIFO mode is disabled.
D4	SSI mode TXRDY for DMA	1	This bit function is available only when SSI mode is enabled (bit D5 in IER is set). This bit is the compliment of TXRDY pin and is used to support DMA transfers in a polled environment. A logic 1 indicates transmitter is less than full and is ready for DMA transfer.
		0	A logic 0 indicates transmitter is full and not ready for DMA transfer. Also when SSI mode is disabled this bit will be reset to 0.
D5	SSI mode RXRDY for DMA	1	This bit function is available only when SSI mode is enabled (bit D5 in IER is set). This bit is the compliment of RXRDY pin and is used to support DMA transfers in a polled environment. A logic 1 indicates receiver is not empty and is ready for DMA transfer.
		0	A logic 0 indicates receiver is empty and not ready for DMA transfer. Also when SSI mode is disabled this bit will be reset to 0.
D6, D7	FIFOs enabled	1	These two bits are set to logic 1 when bit D0 in FCR is set to 1 (FIFO mode enabled).
		0	These two bits are reset to logic 0 when bit D0 in FCR is reset to 0 (FIFO mode disabled).

SSI 73M550

SSI 73M1550/2550

UART with FIFOs

INTERRUPT PRIORITY TABLE

D3	D2	D1	D0	PRIORITY	TYPE	SOURCE	RESET
0	0	0	1	–	None	None	N/A
0	1	1	0	Highest	Receiver Line Status	Overrun Error, Parity Error, Framing Error or Break Interrupt	Reading the Line Status Register
0	1	0	0	Second	Receive Data Available	Receive Data Available or RCVR FIFO trigger level reached	Reading the Receiver Buffer Register or the RCVR FIFO drops below trigger level
1	1	0	0	Second	Character Timeout Indicator	No characters have been removed from or input to the RCVR FIFO during the last 4 character times and there is at least 1 character in it during this time	Reading the Receiver Buffer Register
0	0	1	0	Third	Transmit Holding Register Empty	Transmit Holding Register Empty or below XMIT FIFO trigger level	Reading IIR Register (if source of interrupt) or Writing to Transmit Holding Register or XMIT FIFO trigger level reached
0	0	0	0	Fourth	Modem Status	Clear to Send or Data Set Ready or Ring Indicator or Data Carrier Detect	Reading the Modem Status Register

FIFO CONTROL REGISTER (FCR) (WRITE ONLY)
UART ADDRESS: A2 - A0 = 010

This is a write only register at the same location as the IIR read only Register. This register is used to enable the FIFOs, clear the FIFOs, set the XMIT and RCVR FIFO trigger level, and select the type of DMA signalling.

BIT	NAME	COND	DESCRIPTION
D0	FIFO Enable	1	Setting this bit to logic 1 enables both XMIT and RCVR FIFOs. This bit must be written as 1 when other FCR bits are written to or they will not be programmed.
		0	Resetting this bit to logic 0 disables the FIFO mode (enables the 73M450 mode) and clears data in both FIFOs when changing from FIFO mode to 73M450 mode and vice versa, data is automatically cleared from FIFOs.
D1	RCVR FIFO Reset	1	Setting this bit to logic 1 clears all data in the RCVR FIFO and resets its counter logic to 0. The shift register is not cleared. The logic 1 written into this bit is self clearing.
D2	XMIT FIFO Reset	1	Setting this bit to logic 1 clears all data in the XMIT FIFO and resets its counter logic to 0. The shift register is not cleared. The logic 1 written into this bit is self clearing.

SSI 73M550

SSI 73M1550/2550

UART with FIFOs

FIFO CONTROL REGISTER (FCR) (WRITE ONLY) (Continued)

BIT	NAME	COND	DESCRIPTION
D3	DMA Mode Select	1	Setting this bit to logic 1 will enable DMA mode 1. In this mode pins $\overline{\text{TXRDY}}$ and $\overline{\text{RXRDY}}$ and bits D4 and D5 in IIR, support multiple DMA transfers.
		0	Resetting this bit to logic 0 will enable DMA mode 0. In this mode, pins $\overline{\text{TXRDY}}$ and $\overline{\text{RXRDY}}$ and bits D4 and D5 in IIR support single DMA transfers.
D5, D4	SSI Mode XMIT Trigger (MSB, LSB)	0/1	These two bits are active in the SSI mode only. The value written into D5 and D4 determine the XMIT FIFO trigger level as described in table below. The THRE interrupt will occur if the XMIT FIFO is below the trigger level and will reset when the XMIT FIFO is filled to trigger level.
D7, D6	RCVR Trigger (MSB, LSB)	0/1	The value written into D7 and D6 determining the RCVR FIFO trigger level as described in table below. The received data available interrupt will occur if the RCVR FIFO is filled to or above the trigger level and will reset when the RCVR FIFO drops below the trigger level.

D5	D4	XMIT FIFO Trigger Level (Bytes)
0	0	01
0	1	04
1	0	08
1	1	14

D7	D6	RCVR FIFO Trigger Level (Bytes)
0	0	01
0	1	04
1	0	08
1	1	14

SSI 73M550

SSI 73M1550/2550

UART with FIFOs

LINE CONTROL REGISTER (LCR)
UART ADDRESS: A2 - A0 = 011

The user specifies the format of the asynchronous data communications exchange via the Line Control Register. In addition to controlling the format the user may retrieve the contents of the Line Control Register for inspection. This feature simplifies system programming and eliminates the need for separate storage in system memory of the line characteristics.

BIT	NAME	COND		DESCRIPTION	
D0/D1	Word Length Select 0 (WLS0)			Bits D0 and D1 select the number of data bits per character as shown:	
	Word Length Select 1 (WLS1)	D1	D0	Word Length	
		0	0	5 bits	
		0	1	6 bits	
		1	0	7 bits	
	1	1	8 bits		
D2	Number of Stop Bits (STB)	0 or 1		This bit specifies the number of stop bits in each transmitted character. If bit D2 is a logic 0, one stop bit is generated in the transmitted data. If bit D2 is a logic 1 when a 5-bit word length is selected via bits D0 and D1, one-and-a-half stop bits are generated. If bit D2 is a logic 1 when either a 6, 7, or 8-bit word length is selected, two stop bits are generated. The receiver checks the first stop bit only, regardless of the number of stop bits selected.	
D3	Parity Enable (PEN)	1		This is the Parity Enable (PEN) bit. When set to a logic 1, a parity bit is generated (transmit data) or checked (receive data) between the last data word bit and stop bit of the serial data. (The parity bit is used to produce an even or odd number of 1's when the data word bits and the parity bit are summed).	
D4	Even Parity Select (EPS)	1 or 0		This is the Even Parity Select (EPS) bit. When bit D3 is a logic 1 and bit D4 is a logic 0, an odd number of logic 1's is transmitted or checked in the data word bits and parity bit. When bit D3 is a logic 1 and bit D4 is a logic 1 an even number of logic 1's is transmitted or checked.	
D5	Stick Parity	1 or 0		This is the Stick Parity bit. When bit D3 is a logic 1 and bit D5 is a logic 1 the parity bit is transmitted and checked by the receiver as a logic 0 if bit D4 is a logic 1 or as a logic 1 if bit D4 is a logic 0.	
		D5	D4		Parity
		0	0		ODD Parity
		0	1		EVEN Parity
		1	0		MARK Parity
	1	1	SPACE Parity		

SSI 73M550

SSI 73M1550/2550

UART with FIFOs

LINE CONTROL REGISTER (LCR) (Continued)

BIT	NAME	COND	DESCRIPTION
D6	Set Break	1	This is the Break Control bit. It causes a break condition to be sent to the receiving UART. When set to a logic 1 the serial out (SOUT) is forced to a logic 0 state. The break is disabled by setting bit D6 to a logic 0. This bit acts only on SOUT and has no effect on the transmitter logic. See note below.
D7	Divisor Latch Access Bit (DLAB)	1	The Divisor Latch Access Bit (DLAB) must be set high (logic 1) to access the Divisor Latches of the baud generator during a Read or Write operation. It must be set low (logic 0) to access the Receiver Buffer, the Transmitter Holding Register, or the Interrupt Enable Register.

NOTE: This feature enables the CPU to alert a terminal in a computer communications system. If the following sequence is followed, no erroneous or extraneous characters will be transmitted because of the break.

1. Load an all 0's pad character in response to THRE.
2. Set break in response to the next THRE.
3. Wait for the Transmitter to be idle. (TEMT = 1), and clear break when normal transmission has to be restored.

During the break, the Transmitter can be used as a character timer to accurately establish the break duration.

MODEM CONTROL REGISTER (MCR)

UART ADDRESS: A2 - A0 = 100

The Modem Control Register controls the interface with the modem, data set or peripheral device.

BIT	NAME	COND	DESCRIPTION
D0	DTR	0/1	This bit controls the Data Terminal Ready (\overline{DTR}) output. When bit 0 is set to a logic 1 the \overline{DTR} output is forced to a logic 0. When bit 0 is reset to a logic 0 the \overline{DTR} output is forced to a logic 1.
D1	RTS	0/1	This bit controls the Request to Send (\overline{RTS}) output. When bit 1 is set to a logic 1 the \overline{RTS} output is forced to a logic 0. When bit 1 is reset to a logic 0 the \overline{RTS} output is forced to a logic 1.
D2	OUT1	0/1	This bit controls the Output 1 ($\overline{OUT1}$) signal, an auxiliary user-designated output. When bit D2 is set to a logic 1, $\overline{OUT1}$ is forced to a logic 0. When bit D2 is reset to a logic 0, $\overline{OUT1}$ is forced to a logic 1. On the SSI 73M2550 only, this bit controls the μ PRST output. When bit D2 is set to a logic 1, the μ PRST output is forced to a logic 1. When bit D2 is reset to logic 0, μ PRST is forced to logic 0.
D3	OUT2	0/1	This bit controls the Output 2 ($\overline{OUT2}$) signal, an auxiliary user-designated output. When bit D3 is set to a logic 1, $\overline{OUT2}$ forced to a logic 0. When bit D3 is reset to a logic 0, $\overline{OUT2}$ output is forced to a logic 1. On the 28-pin versions, this bit controls the INTRPT pin. When bit D3 is set to a logic 1, the INTRPT output is enabled. When bit D3 is reset to logic 0, the INTRPT pin is forced into a high impedance state.

SSI 73M550 SSI 73M1550/2550 UART with FIFOs

MODEM CONTROL REGISTER (MCR) (Continued)

BIT	NAME	COND	DESCRIPTION
D4	LOOP	0/1	This bit provides a local loopback feature for diagnostic testing of the UART. When bit 4 is set to logic 1, the following occurs: the transmitter Serial Output (SOUT) is set to the logic 1 state; the receiver Serial Input (SIN) is disconnected; the output of the Transmitter Shift Register is "looped back" into the Receiver Shift Register input; the four Modem Control inputs (\overline{CTS} , \overline{DSR} , \overline{DCD} and \overline{RI}) are disconnected; the four Modem Control outputs (\overline{DTR} , \overline{RTS} , $\overline{OUT1}$ and $\overline{OUT2}$) are internally connected to the four Modem Control inputs, and the Modem Control output pins are forced to their inactive state (high). In the diagnostic mode, data that is transmitted is immediately received. This feature allows the processor to verify the transmit and received-data paths of the UART. In the diagnostic mode, the receiver and transmitter interrupts are fully operational. The Modem Control Interrupts are also operational, but the interrupts' sources are now the lower four bits of the Modem Control Register instead of the four Modem Control inputs. The interrupts are still controlled by the Interrupt Enable Register.
D5-D6		0	These bits are permanently set to logic 0.
D7	SSi Mode Osc. off	1	This bit is active in the SSi Mode only. When D7 is set the UART oscillator is turned off placing the UART in a power shutdown state. All UART memory is retained during power shutdown.
		0	Resetting this bit enable the oscillator and powers up the UART.

LINE STATUS REGISTER (LSR)

UART ADDRESS: A2 - A0 = 101

This register provides status information to the CPU concerning the data transfer. Bits D1-D4 are the error conditions that produce a Receiver Line Status interrupt whenever any of the corresponding conditions are detected. The Line Status Register is intended for read operation only. Writing to this register is not recommended as this operation is used for factory testing.

BIT	NAME	COND	DESCRIPTION
D0	DR	0/1	The Data Ready (DR) bit is set to a 1 whenever a complete incoming character has been received and transferred into the Receiver Buffer Register. DR is reset to 0 by reading all data in the Receiver Buffer Register FIFO.
D1	OE	0/1	The Overrun Error (OE) bit is set when data in the Receiver Buffer Register was not read by the CPU before the next character was transferred into the Receiver Buffer Register, thereby destroying the previous character. OE is reset to 0 whenever the CPU reads the contents of the Line Status Register. In FIFO mode if data continues to fill the FIFO beyond the trigger level an overrun error will occur only after the FIFO is full and the next character has been completely received in (Continued)

SSI 73M550

SSI 73M1550/2550

UART with FIFOs

LINE STATUS REGISTER (LSR) (Continued)

BIT	NAME	COND	DESCRIPTION
D1	OE	0/1	the shift register. OE is indicated to the CPU as soon as it occurs. The character in the shift register is overwritten but it is not transferred to the FIFO.
D2	PE	0/1	The Parity Error (PE) bit is set when the received character did not have the correct parity. PE is reset to 0 whenever the CPU reads the Line Status Register. In FIFO mode this error is revealed to the CPU when its associated character is at the top of the FIFO.
D3	FE	1	The Framing Error (FE) bit indicates that the received character did not have a valid stop bit. FE is reset to 0 whenever the CPU reads the contents of the Line Status Register. In the FIFO mode this error is revealed to the CPU when its associated character is at the top of the FIFO. The UART will try to resynchronize after a framing error. To do this it assumes that the framing error was due to the next start bit, so it samples the following start bit twice and then takes in the data that follows.
D4	BI	1	The Break Interrupt (BI) bit is set when a break has been received. A break occurs whenever the received data is held to 0 for a full data word (start + data + stop). BI is reset to 0 whenever the CPU reads the Line Status Register. In the FIFO mode this error is revealed to the CPU when its associated character is at the top of the FIFO. When break occurs only one zero character is loaded into the FIFO. The next character transfer is enabled after SIN goes to the marking (high) state and receives the next valid start bit.
D5	THRE	1	The Transmit Holding Register Empty (THRE) is set to a logic 1 when a character is transferred from the Transmit Holding Register into the Transmit Shift Register, indicating that the UART is ready to accept a new character for transmission. In addition this bit causes the UART to issue an interrupt to the CPU when the THRE Interrupt enable is set high. THRE is reset to 0 when the CPU loads a character into the Transmit Holding Register. In the FIFO mode this bit is set when the XMIT FIFO is filled below the trigger level and will reset when the FIFO is filled to the trigger level.
D6	TEMT	1	The Transmit Empty (TEMT) indicates that both the Transmit Holding Register and the Transmit Shift Registers are empty. TEMT is reset to 0 whenever the TSR or THR contains a data character. In the FIFO mode this bit is set whenever the XMIT FIFO and the transmitter shift register are both empty.
D7	Error in Rcvr FIFO	0	In the character mode this bit is reset to 0. In the FIFO mode this bit is set when there is at least one parity error, framing error or break indication in the FIFO. This bit is reset when the CPU reads the Line Status Register if there are no subsequent errors in the FIFO.
<p>Note: Bits D1-D4 are the error conditions that produce a Receiver Line Status interrupt whenever any of the corresponding conditions are detected and the interrupt is enabled.</p>			

SSI 73M550 SSI 73M1550/2550 UART with FIFOs

MODEM STATUS REGISTER (MSR) (READ ONLY)
UART ADDRESS: A2 - A0 = 110

This register provides the current state of the control signals from the modem or peripheral device. In addition four bits provide change information. Whenever bit D0, D1, D2 or D3 is set to logic 1 a Modem Status Interrupt is generated; reset to logic 0 occurs whenever they are read. In Loop Mode CTS, DSR, RI and DCD are taken from RTS, DTR, OUT1, and OUT2 in the Modem Control Register, respectively.

BIT	NAME	COND	DESCRIPTION
D0	DCTS	1	The Delta Clear to Send (DCTS) bit is set when the \overline{CTS} input to the chip has changed state since the last time it was read by the CPU.
D1	DDSR	1	The Delta Data Set Ready (DDSR) bit is set when the \overline{DSR} input to the chip has changed state since the last time it was read by the CPU.
D2	TERI	1	The Trailing Edge of the Ring Indicator (TERI) detect bit is set when the \overline{RI} input to the chip has changed from an Off (logic 0) to an On (logic 1) condition.
D3	DDCD	1	The Delta Data Carrier Detect (DDCD) bit indicates that the \overline{DCD} input to the chip has changed state.
D4	CTS	1	This bit is the complement of the Clear To Send (\overline{CTS}) input. If bit 4 (loop) of the MCR is set to a 1, this bit is equivalent to RTS in the MCR.
D5	DSR	1	This bit is the complement of the Data Set Ready (\overline{DSR}) input. If bit 4 of the MCR is set to a 1, this bit is the equivalent of DTR in the MCR.
D6	RI	1	This bit is the complement of the Ring Indicator (\overline{RI}) input. If bit 4 of the MCR is set to a 1, this bit is equivalent to OUT1 in the MCR.
D7	DCD	1	This bit is the complement of the Data Carrier Detect (\overline{DCD}) input. If bit 4 of the MCR is set to a 1, this bit is equivalent to OUT2 in the MCR.

SCRATCH REGISTER (SCR)
ADDRESS: A2 - A0 = 111

This 8-bit Read/Write Register does not control the UART in any way. It is intended as a scratchpad register to be used by the programmer to hold data temporarily.

DIVISOR LATCH (LS) (DLL)
ADDRESS: A2 - A0 = 000, DLAB = 1

This register contains the least significant byte of the divisor which is used to control the rate of the programmable baud generator.

DIVISOR LATCH (MS) (DLM)
ADDRESS: A2 - A0 = 001, DLAB = 1

This register contains the most significant byte of the divisor which is used to control the rate of the programmable baud generator.

SSI 73M550

SSI 73M1550/2550

UART with FIFOs

PROGRAMMABLE BAUD GENERATOR

The UART contains a programmable Baud Generator that is capable of taking any clock input (DC to 8 MHz) and dividing it by any divisor from 2 to $2^{16}-1$. 4 MHz is the highest input clock frequency recommended when the divisor = 1. The output frequency of the Baud Generator is 16 x the Baud [divisor # = (frequency input)/(baud rate x 16)]. Two 8-bit latches store the divisor in a 16-bit binary format. These Divisor Latches must be loaded during initialization in order to ensure desired operation of the Baud Generator. Upon loading either of the Divisor Latches, a 16-bit Baud counter is immediately loaded. This prevents long counts on initial load.

Tables 3, 4 and 5 illustrate the use of the Baud Generator with crystal frequencies of 1.8432 MHz, 3.072 MHz, and 8 MHz respectively. For baud rates of 38400 and below, the error obtained is minimal. The accuracy of the desired baud rate is dependent on the crystal frequency chosen.

DESIRED BAUD RATE (BIT RATE CLOCK)	DIVISOR USED TO GENERATE 16 X CLOCK	PERCENT ERROR DIFFERENCE BETWEEN DESIRED AND ACTUAL
50	2304	-
75	1536	-
110	1047	0.026
134.5	857	0.058
150	768	-
300	384	-
600	192	-
1200	96	-
1800	64	-
2000	58	0.69
2400	48	-
3600	32	-
4800	24	-
7200	16	-
9600	12	-
19200	6	-
38400	3	-
56000	2	2.86

TABLE 3: Baud Rates using 1.8432 MHZ Crystal

SSI 73M550
SSI 73M1550/2550
UART with FIFOs

DESIRED BAUD RATE (BIT RATE CLOCK)	DIVISOR USED TO GENERATE 16 X CLOCK	PERCENT ERROR DIFFERENCE BETWEEN DESIRED AND ACTUAL
50	3840	-
75	2560	-
110	1745	0.026
134.5	1428	0.034
150	1280	-
300	640	-
600	320	-
1200	160	-
1800	107	0.312
2000	96	-
2400	80	-
3600	53	0.628
4800	40	-
7200	27	1.23
9600	20	-
19200	10	-
38400	5	-

TABLE 4: Baud Rates using 3.072 MHz Crystal

DESIRED BAUD RATE (BIT RATE CLOCK)	DIVISOR USED TO GENERATE 16 X CLOCK	PERCENT ERROR DIFFERENCE BETWEEN DESIRED AND ACTUAL
50	10000	-
75	6667	0.005
110	4545	0.010
134.5	3717	0.013
150	3333	0.010
300	1667	0.020
600	833	0.040
1200	417	0.080
1800	277	0.080
2000	250	-
2400	208	0.160
3600	139	0.080
4800	104	0.160
7200	69	0.644
9600	52	0.160
19200	26	0.160
38400	13	0.160
56000	9	0.790
128000	4	2.344

TABLE 5: Baud Rates using 8 MHz Crystal

SSI 73M550

SSI 73M1550/2550

UART with FIFOs

FIFO INTERRUPT MODE OPERATION

When the RCVR FIFO and receiver interrupts are enabled (FCR D0 = 1, IER D0 = 1) RCVR interrupts will occur as follows:

- A. The receive data available interrupt will be issued to the CPU when the FIFO has reached its programmed trigger level; it will be cleared as soon as the FIFO drops below its programmed trigger level.
- B. The IIR receive data available indication also occurs when the FIFO trigger level is reached and like the interrupt it is cleared when the FIFO drops below the trigger level.
- C. The receiver line status interrupt (IIR = 06), as before, has higher priority than the received data available (IIR = 04) interrupt.
- D. The data ready bit (LSRD0) is set as soon as a character is transferred from the shift register to the RCVR FIFO. It is reset when the FIFO is empty.

When RCVR FIFO and receiver interrupts are enabled, RCVR FIFO timeout interrupts will occur as follows:

- A. A FIFO timeout interrupt will occur, if the following conditions exist:
 - at least one character is in the FIFO
 - the most recent serial character received was longer than 4 continuous character times ago (if 2 stop bits are programmed the second one is included in this time delay).
 - the most recent CPU read of the FIFO was longer than 4 continuous character times ago.

This will cause a maximum character received to interrupt issued delay of 160 ms at 300 baud with a 12 bit character.

- B. Character times are calculated by using the RCLK input for a clock signal (this makes the delay proportional to the baud rate).
- C. When a timeout interrupt has occurred it is cleared and the timer reset when the CPU reads one character from the RCVR FIFO.
- D. When a timeout interrupt has not occurred the timeout timer is reset after a new character is received or after the CPU reads the RCVR FIFO.

When the XMIT FIFO and transmitter interrupts are enabled (FCRD0 = 1, IERD1 = 1), XMIT interrupts will occur as follows:

- A. The transmitter holding register interrupt occurs when the XMIT FIFO is below the trigger level. It is cleared as soon as the transmitter holding register is written to and reaches the trigger level or the IIR is read. If the SSI mode is disabled (IER D5 = 0) then the XMIT FIFO trigger level is set to 1 byte.
- B. The transmitter FIFO empty indications will be delayed 1 character time minus the last stop bit time whenever the following occurs: THRE = 1 and there have not been at least two bytes at the same time in the transmit FIFO since the last THRE = 1. The first transmitter interrupt after changing FCR D0 will be immediate, if it is enabled.

Character timeout and RCVR FIFO trigger level interrupts have the same priority as the current received data available interrupt; XMIT FIFO empty has the same priority as the current transmitter holding register empty interrupt.

FIFO MODE OPERATION

With FCR D0 = 1 resetting IER D0, IER D1, IER D2, IER D3 or all to zero puts the UART in the FIFO polled mode of operation. Since the RCVR and XMITTER are controlled separately either one or both can be in the polled mode of operation. In this mode the users program will check RCVR and XMITTER status via the LSR. As stated previously:

LSR D0 will be set as long as there is one byte in the RCVR FIFO

LSR D1 to LSR D4 will specify which error(s) has occurred. Character error status is handled the same way as when in the interrupt mode, the IIR is not affected since IER D2 = 0

LSR D5 will indicate when the XMIT FIFO is empty.

LSR D6 will indicate that both the XMIT FIFO and shift register are empty.

LSR D7 will indicate whether there are any errors in the RCVR FIFO.

There is no trigger level reached or timeout condition indicated in the FIFO Polled Mode, however, the RCVR and XMIT FIFOs are still fully capable of holding characters.

SSI 73M550 SSI 73M1550/2550 UART with FIFOs

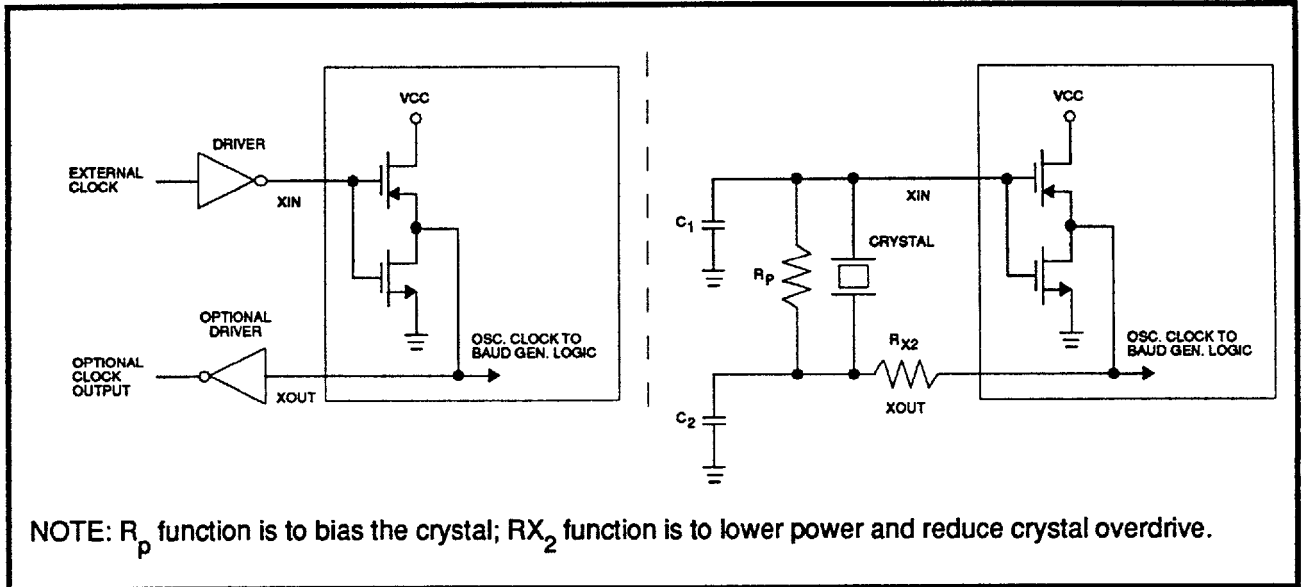

FIGURE 1: Typical Clock Circuits

TYPICAL CRYSTAL OSCILLATOR NETWORK

CRYSTAL	RP	RX2	C1	C2
1.8 - 8 MHz	1 M Ω	1.5K	10-30 pF	40-60 pF
8 MHz	1 M Ω	0	10-30 pF	40-60 pF

ELECTRICAL SPECIFICATIONS

ABSOLUTE MAXIMUM RATINGS

($T_A = -40^\circ\text{C}$ to $+85^\circ\text{C}$, $V_{CC} = 5V \pm 10\%$, unless otherwise noted. Operation above absolute maximum ratings may permanently damage the device.)

PARAMETER	RATING
VCC Supply Voltage	+7V
Storage Temperature	-65°C to 150°C
Lead Temperature	Soldering, 10 sec. 260°C
Applied Voltage	-0.3 to $V_{CC} + 0.3$

SSI 73M550

SSI 73M1550/2550

UART with FIFOs

DC CHARACTERISTICS

(TA = -40°C to +85°C, VCC = 5V ± 10%, VSS = 0V, unless otherwise noted; positive current is defined as entering the chip.)

PARAMETER	CONDITIONS	MIN	NOM	MAX	UNITS
VILX	Clock input Low voltage	-0.5		0.8	V
VIHX	Clock input High Voltage	2.0		Vcc	V
VIL	Input Low Voltage	-0.5		0.8	V
VIH	Input High Voltage	See Note 1		Vcc	V
VOL	Output Low Voltage	IOL = 4.0 mA (except XOUT)		0.4	V
VOH	Output High Voltage	IOH = -5.0 mA on all outputs except XOUT	2.4		V
ICC	Average Power Supply Current	See Note 2	5	10	mA
		See Note 3	50		µA
IIL	Input Leakage	VCC=5.25V, VSS=0V. All other pins floating.		±10	µA
ICL	Clock Leakage	VIN=0V, 5.25V		±10	µA
IOZ	3-State Leakage	VCC=5.25V, VSS=0V, VOUT=0V, 5.25V 1) Chip deselected 2) Chip & write mode selected		±20	µA
VILMR	MR Schmitt VIL			0.8	V
VIHMR	MR Schmitt VIH		2.0		V
Note 1: All pins except \overline{DCD} , \overline{DSR} and \overline{CTS} pins. VIH for these pins is >2.2V.					
Note 2: VCC = 5.25V, TA = 25°C; No loads on outputs. SIN, \overline{DSR} , \overline{DCD} , \overline{CTS} , \overline{RI} = 2.4V. All other inputs = 0.4V. Baud Rate Gen. = 4 MHz; Baud Rate = 50 kHz.					
Note 3: VCC = 5.5V, TA = -40°C; No output load; CMOS-level inputs, oscillator disabled.					

CAPACITANCE

(TA = 25°C, VCC = VSS = 0V, fc = 1 MHz, unmeasured pins returned to VSS)

PARAMETER	CONDITIONS	MIN	NOM	MAX	UNITS
CXTAL2	Clock Input Capacitance		15	20	pF
CXTAL1	Clock Output Capacitance		20	30	pF
CI	Input Capacitance		6	10	pF
CO	Output Capacitance		10	20	pF

SSI 73M550 SSI 73M1550/2550 UART with FIFOs

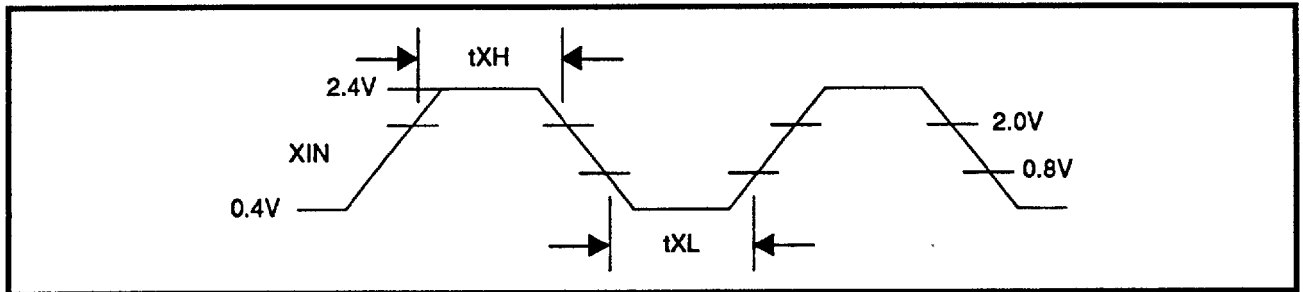

FIGURE 2: External Clock Input* (8 MHz Maximum)

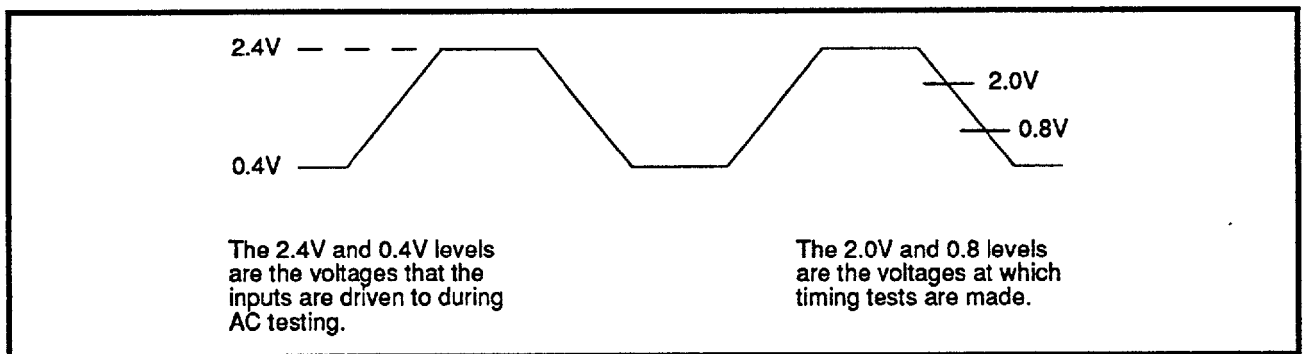

FIGURE 3: AC Test Points*

*All timings are referenced to valid 0 and valid 1.

AC CHARACTERISTICS (TA = -40°C to +85°C, VCC = 5V ±10%, unless otherwise noted.)

READ & WRITE CYCLE (Refer to Figures 4 & 5)

PARAMETER	CONDITIONS	73M550 73M1550 73M2550		UNITS
		MIN	MAX	
tADS	Address Strobe Width	50		ns
tAS	Address Setup Time	30		ns
tAH	Address Hold Time	0		ns
tCS	Chip Select Setup Time	30		ns
tCH	Chip Select Hold Time	0		ns
tAR	READ Delay from Address	30		ns

SSI 73M550

SSI 73M1550/2550

UART with FIFOs

READ & WRITE CYCLE (Continued)

PARAMETER	CONDITIONS	73M550 73M1550 73M2550		UNITS
		MIN	MAX	
tRD	READ Strobe Width	80		ns
tRC	Read Cycle Delay	50		ns
tAD	Address to Read Data		160	ns
RC	Read Cycle	See Note 1 & 4		ns
tRDD	READ to Driver Disable Delay	100 pF load See Note 2		ns
tRVD	Delay from READ to Data	100 pF load		ns
tHZ	READ to Floating Data Delay	100 pF load See Note 2		ns
tRA	Address Hold Time from READ	See Note 3		ns
tAW	WRITE Delay from Address	See Note 3		ns
tWR	WRITE Strobe Width	80		ns
tWC	Write Cycle Delay	50		ns
WC	Write Cycle = tAW+tWR+tWC	160		ns
tDS	Data Setup Time	30		ns
tDH	Data Hold Time	30		ns
tWA	Address Hold Time from WRITE	See Note 3		ns
tMRW	Master Reset Pulse Width	1		μs
tXH	Duration of Clock High Pulse	External Clock (4 MHz max.)		ns
tXL	Duration of Clock Low Pulse	External Clock (4 MHz max.)		ns

Note 1: $RC = tAD + tRC$

Note 2: Charge and discharge time is determined by VOL, VOH and the external loading

Note 3: Applicable only when \overline{ADS} is tied low

Note 4: In FIFO mode $RC = 425$ ns (minimum) between reads of the RCVR FIFO and the status registers (interrupt identification register or line status register).

READ occurs when both read (RD, \overline{RD}) and chip select ($CS0, CS1, \overline{CS2}$, latched by \overline{ADS}) are asserted.

WRITE occurs when both write (WR, \overline{WR}) and chip select ($CS0, CS1, \overline{CS2}$, latched by \overline{ADS}) are asserted.

SSI 73M550 SSI 73M1550/2550 UART with FIFOs

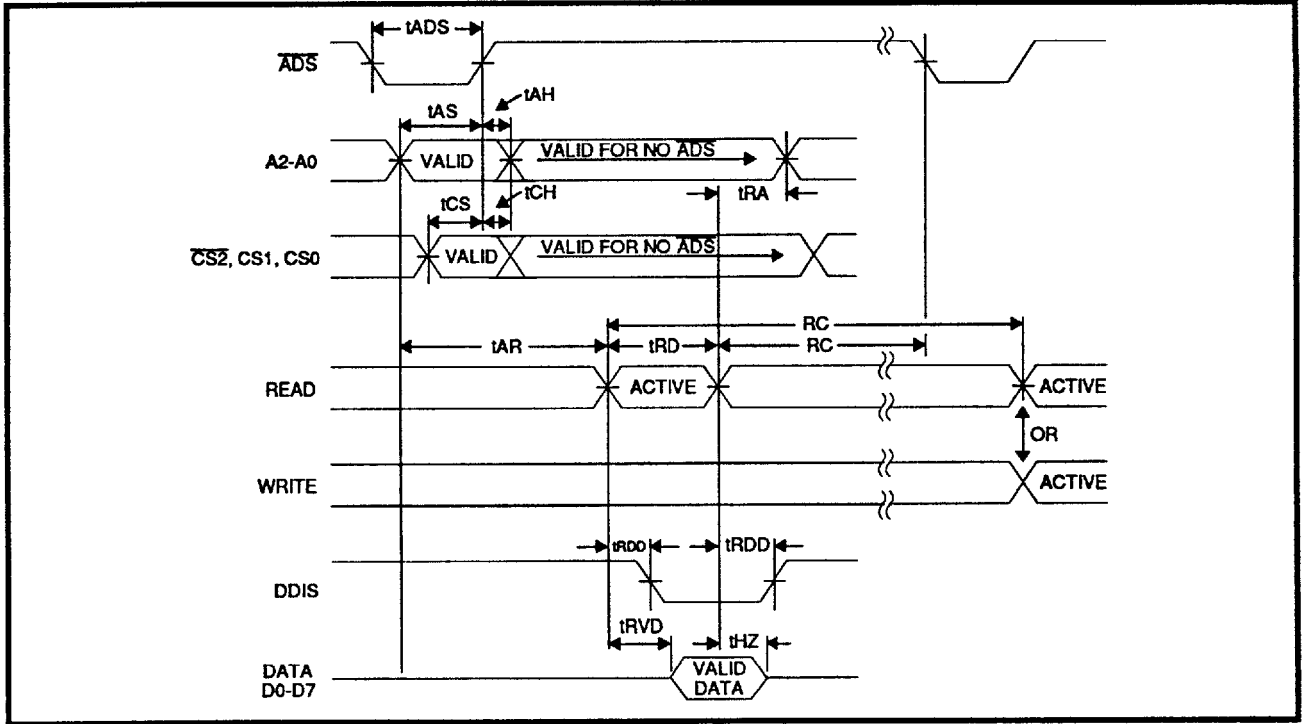

FIGURE 4: Read Cycle Timing

NOTE: READ occurs when both read (RD, \overline{RD}) and chip select (CS0, CS1, $\overline{CS2}$, latched by \overline{ADS}) are asserted.

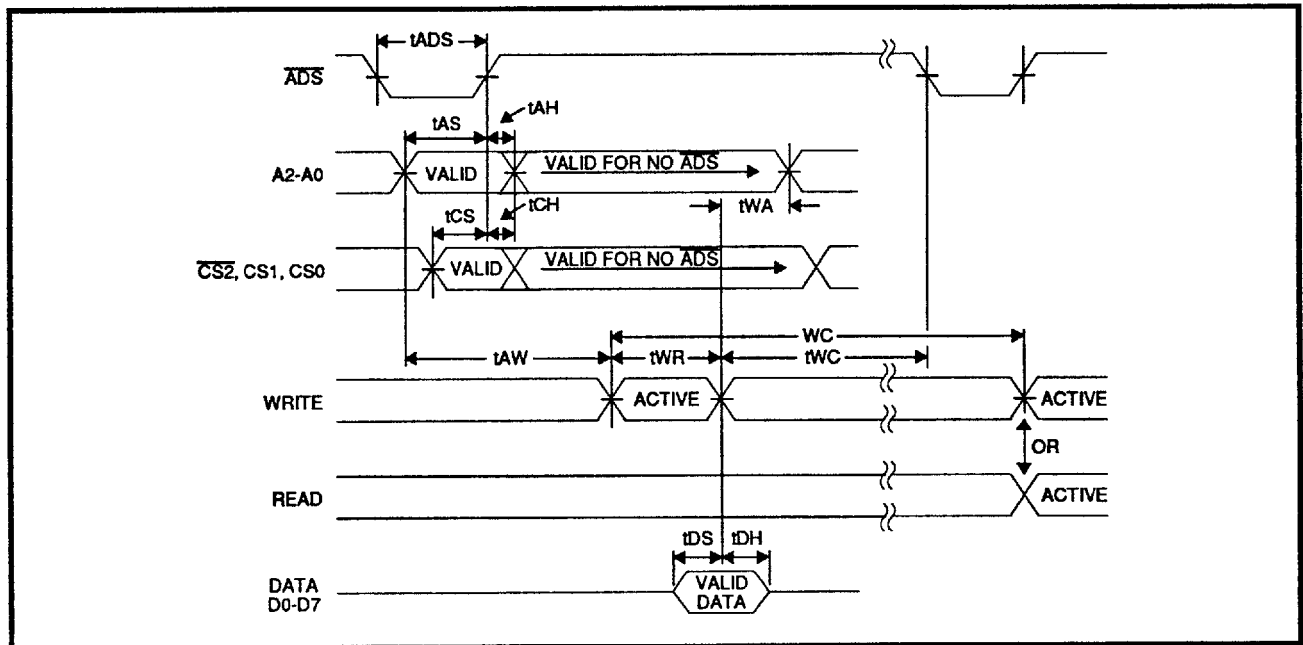

FIGURE 5: Write Cycle Timing

NOTE: WRITE occurs when both write (WR, \overline{WR}) and chip select (CS0, CS1, $\overline{CS2}$, latched by \overline{ADS}) are asserted.

SSI 73M550

SSI 73M1550/2550

UART with FIFOs

TRANSMITTER (Refer to Figure 6)

PARAMETER	CONDITIONS	MIN	MAX	UNITS
t _{HR}	Delay from the end of WRITE to the negation of Interrupt		175	ns
t _{IRS}	Delay from Initial INTR Reset to Transmit Start	8	24	BAUDOUT cycles
t _{SI}	Delay from Initial Write to Interrupt	See Note 1	24	BAUDOUT cycles
t _{STI}	Delay from Stop to Interrupt (THRE)	See Note 1	8	BAUDOUT cycles
t _{IR}	Delay from the end of READ to the negation of Interrupt		250	ns
t _{SXA}	Delay from Start to $\overline{\text{TXRDY}}$ active		8	BAUDOUT cycles
t _{WXI}	Delay from Write to $\overline{\text{TXRDY}}$ inactive		195	ns
Note: This delay will be lengthened by 1 character time, minus the last stop bit time if the transmitter interrupt delay circuit is active (see FIFO Interrupt mode operation).				

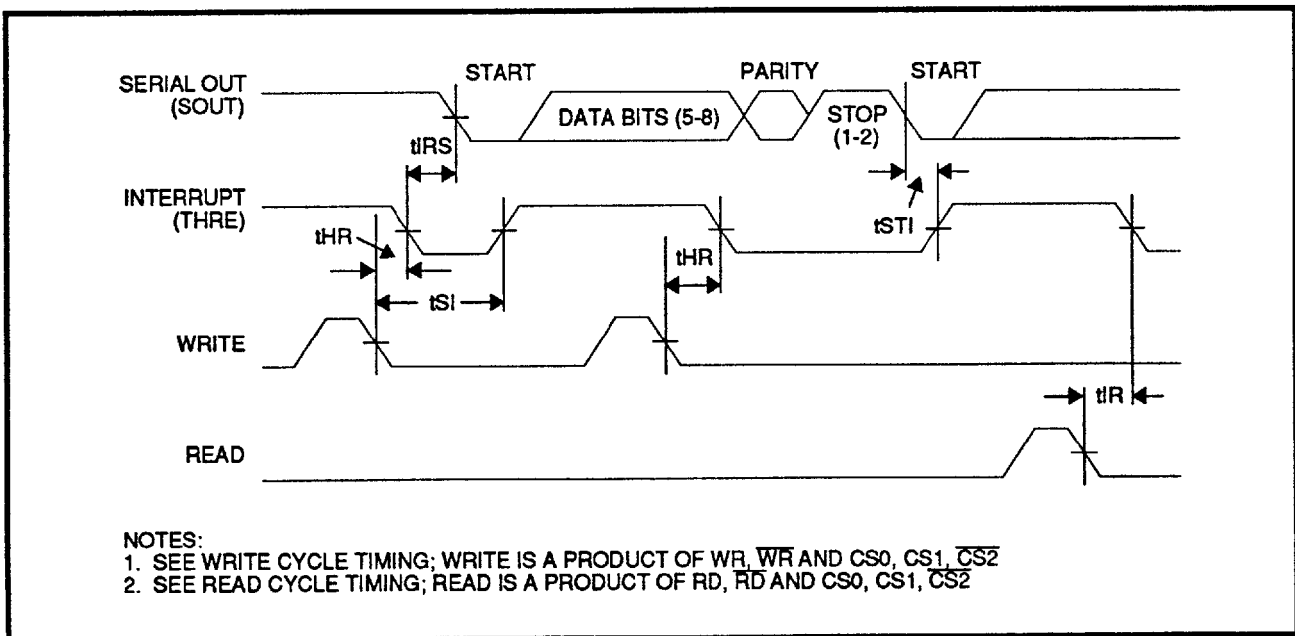

FIGURE 6: Transmitter Timing

SSI 73M550 SSI 73M1550/2550 UART with FIFOs

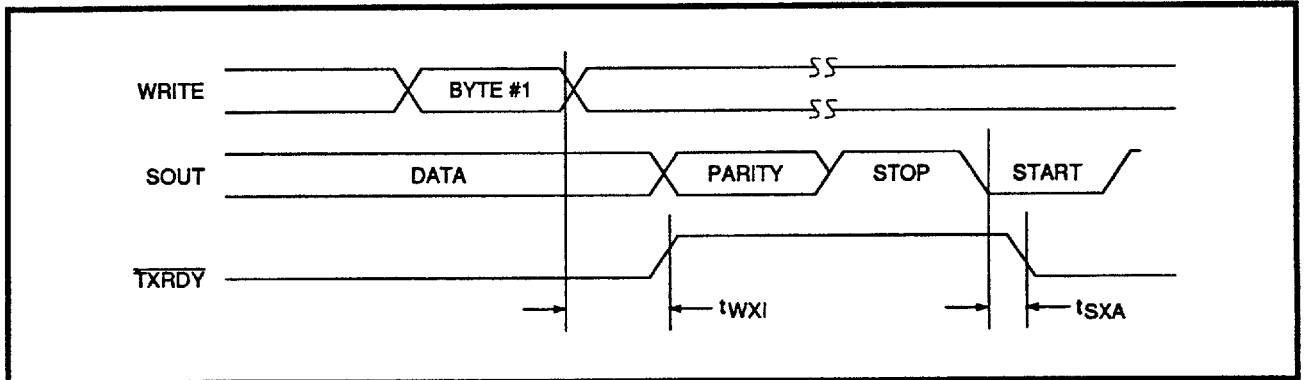

FIGURE 7: Transmitter Ready (Pin 24) FCR D0 = 0 or FCR D0 = 1 and FCR D3 = 0 (Mode 0)

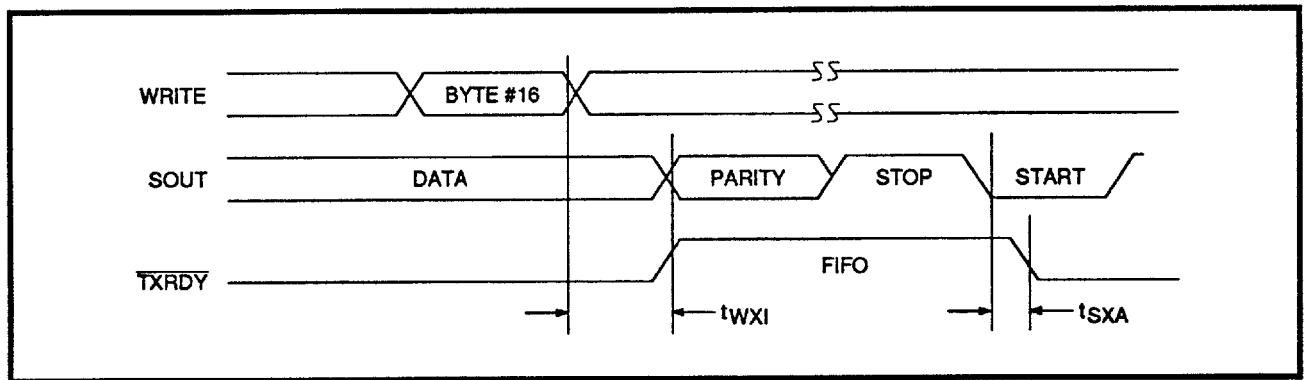

FIGURE 8: Transmitter Ready (Pin 24) FCR D0 = 1 and FCR D3 = 1 (Mode 1)

NOTE: WRITE occurs when both write (\overline{WR}) and chip select ($CS0, CS1, \overline{CS2}$, latched by \overline{ADS}) are asserted.

SSI 73M550

SSI 73M1550/2550

UART with FIFOs

MODEM CONTROL (Refer to Figure 9)

PARAMETER	CONDITIONS	MIN	MAX	UNITS
tMDO	Delay from WRITE MCR to Output		200	ns
tSIM	Delay to Set Interrupt from Modem Input		250	ns
tRIM	Delay to Reset Interrupt from RD, \overline{RD} (RD MSR)		250	ns

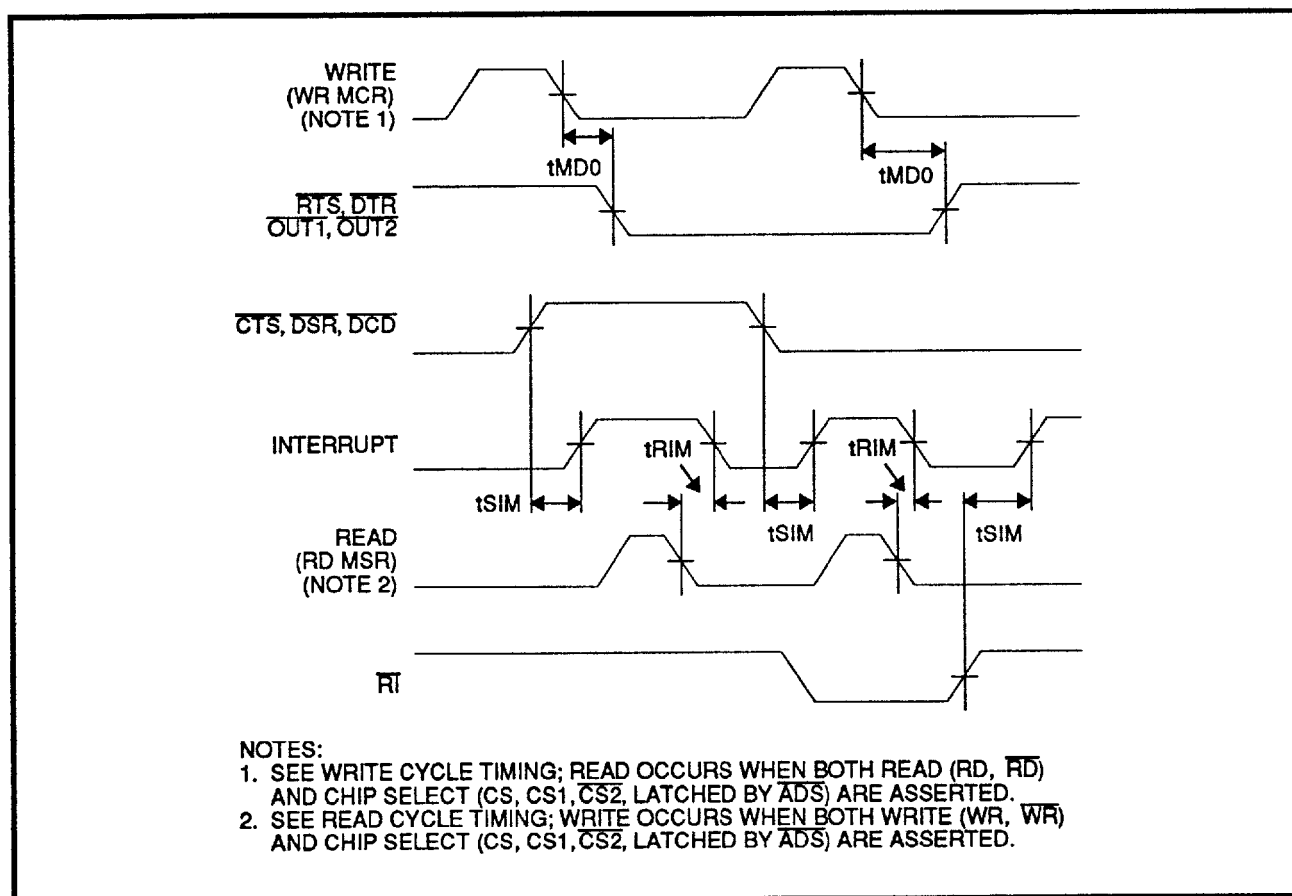

FIGURE 9: Modem Controls Timing

SSI 73M550 SSI 73M1550/2550 UART with FIFOs

BAUD GENERATOR (Refer to Figure 10)

PARAMETER	CONDITIONS	MIN	MAX	UNITS
N Baud Divisor		1	$2^{16}-1$	
tBLD Baud Output Negative Edge Delay	100 pF load		125	ns
tBHD Baud Output Positive Edge Delay	100 pF load		125	ns
tLW Baud Output Down Time	fX=8 MHz, div. by 2, 100 pF load	100		ns
tHW Baud Output Up Time	fX=8 MHz, div. by 2, 100 pF load	75		ns

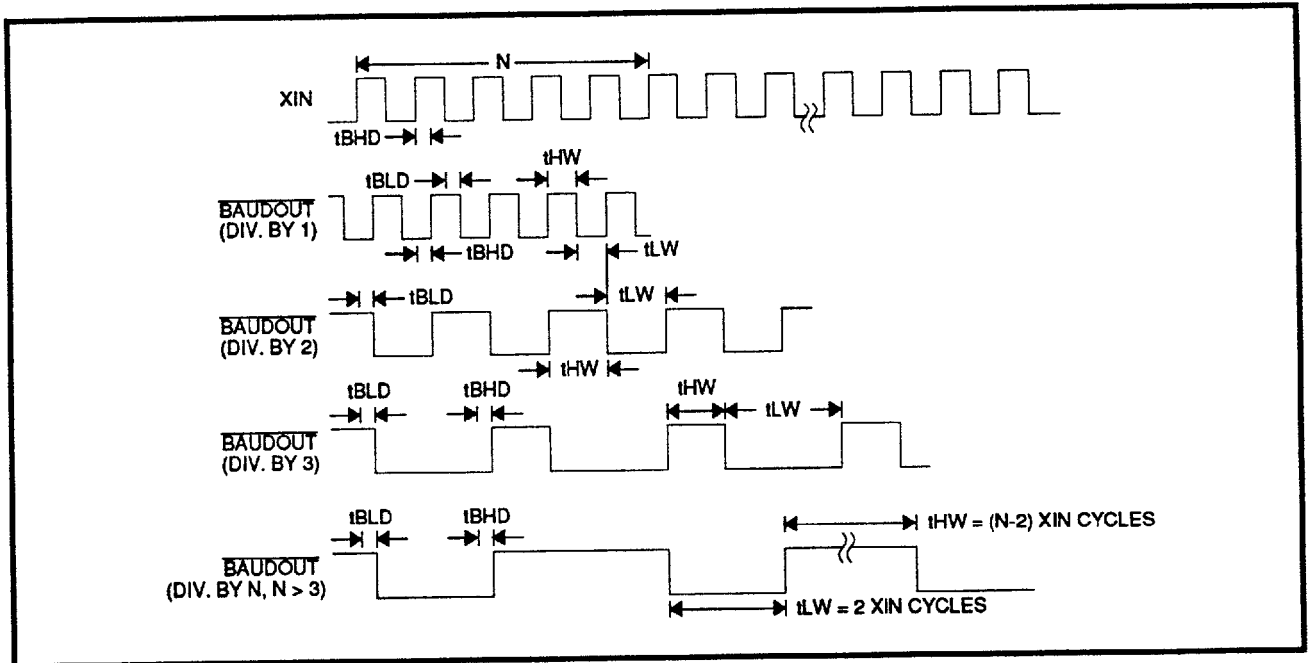

FIGURE 10: BAUDOUT Timing

SSI 73M550

SSI 73M1550/2550

UART with FIFOs

RECEIVER (Refer to Figure 11)

PARAMETER	CONDITIONS	MIN	MAX	UNITS
tSCD	Delay from RCLK to Sample Time		2	μs
tSINT	Delay from Stop to Set Interrupt	RCLK=tXH & tXL See Note 1	1	RCLK cycles
tRINT	Delay from READ (RD RBR/RD LSR) to Reset Interrupt	100 pF load	1	μs

Note 1: In the FIFO mode (FCR D0 = 1) the trigger level interrupts, the receiver data available indication, the active RXRDY indication and the overrun error indication will be delayed 3 RCLKs. Status indicators (PE, FE, BI) will be delayed 3 RCLKs after the first byte has been received. For subsequently received bytes these indicators will be updated immediately after RD RBR goes inactive. Timeout interrupt is delayed 8 RCLKs.

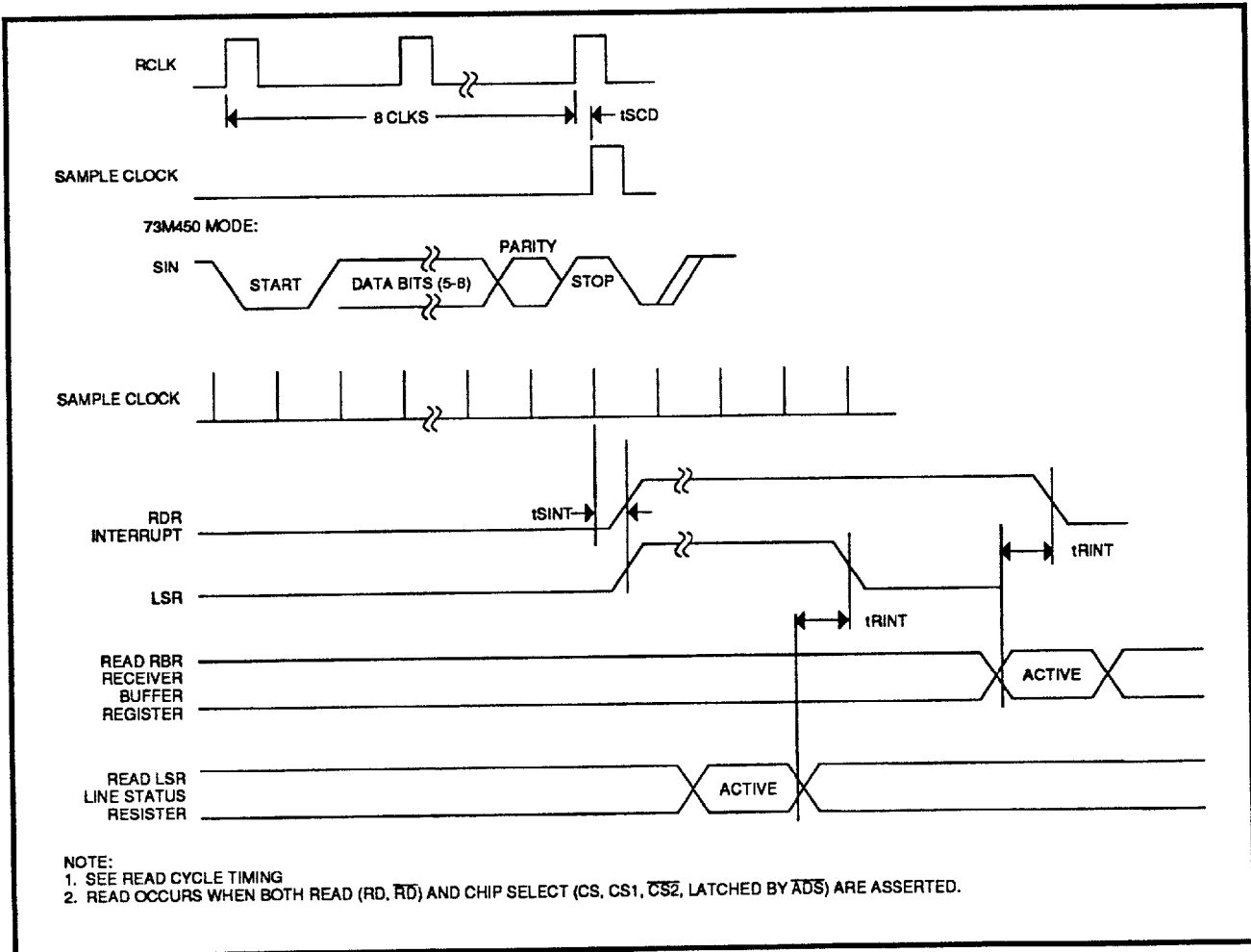

FIGURE 11: Receiver Timing

SSI 73M550 SSI 73M1550/2550 UART with FIFOs

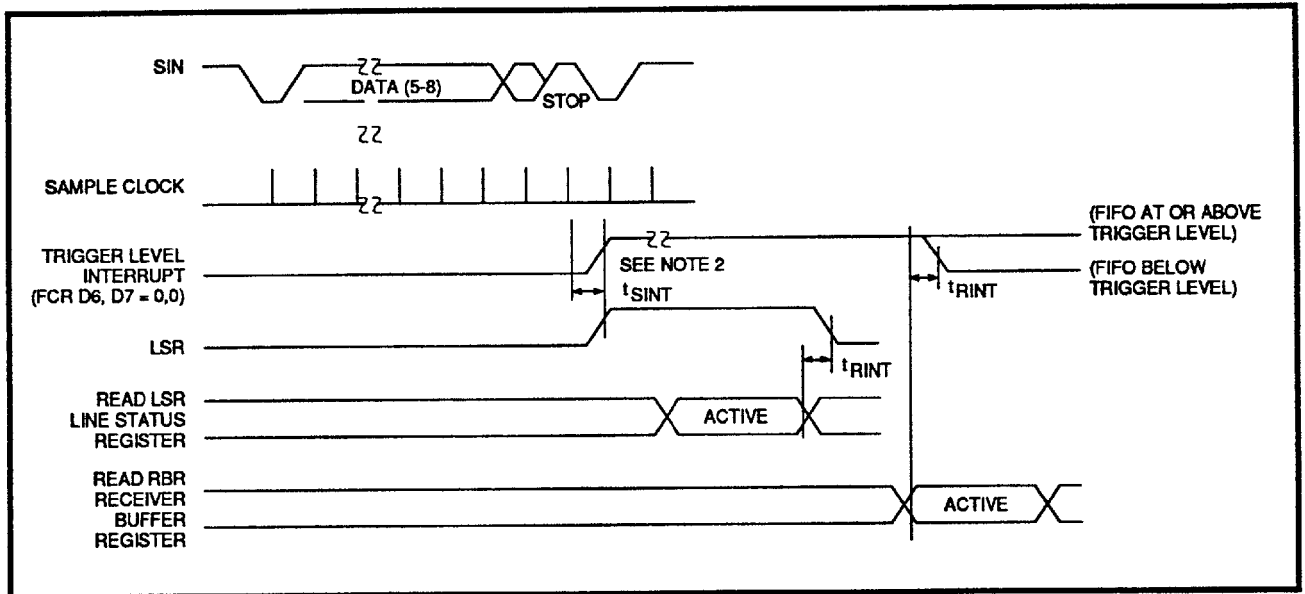

FIGURE 12: RCVR FIFO First Byte (This sets RBR)

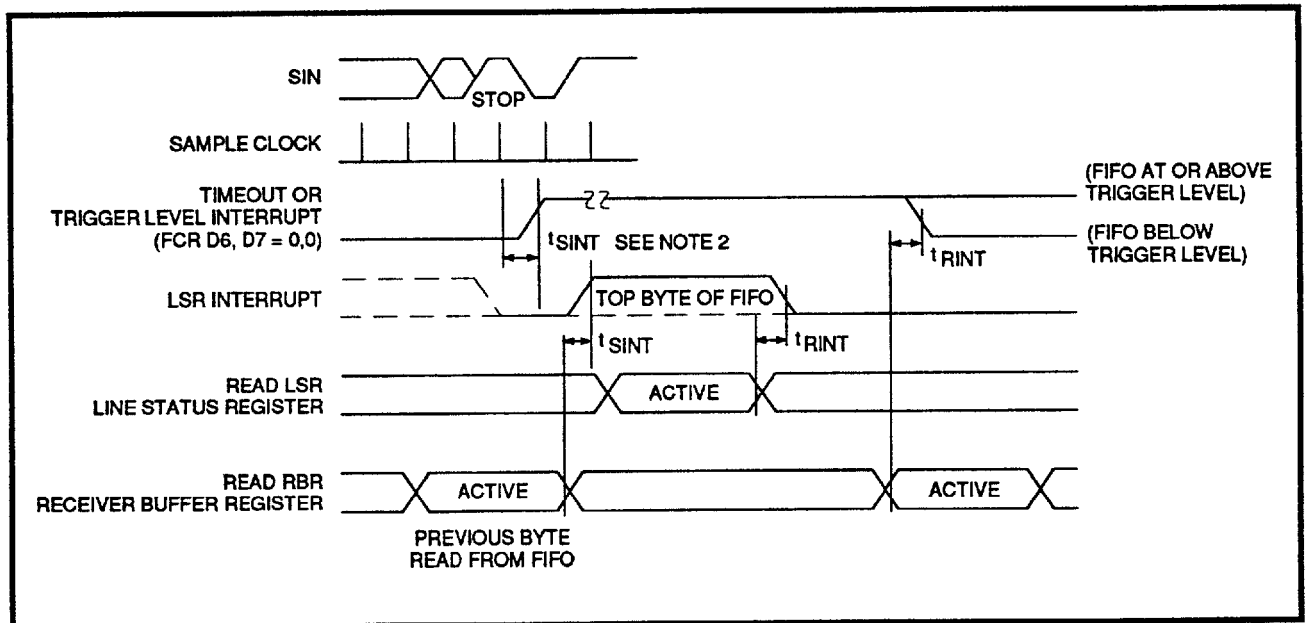

FIGURE 13: RCVR FIFO Bytes Other Than the First Byte (RBR is already set)

Note 1: This is the reading of the last byte in the FIFO

Note 2: If FCR D0 = 1, then $t_{SINT} = 3 \text{ RCLKs}$. For a timeout interrupt, $t_{SINT} = 8 \text{ RCLKs}$.

Note 3: READ occurs when both read (\overline{RD} , \overline{RD}) and chip select ($\overline{CS0}$, $\overline{CS1}$, $\overline{CS2}$, latched by \overline{ADS}) are asserted.

SSI 73M550

SSI 73M1550/2550

UART with FIFOs

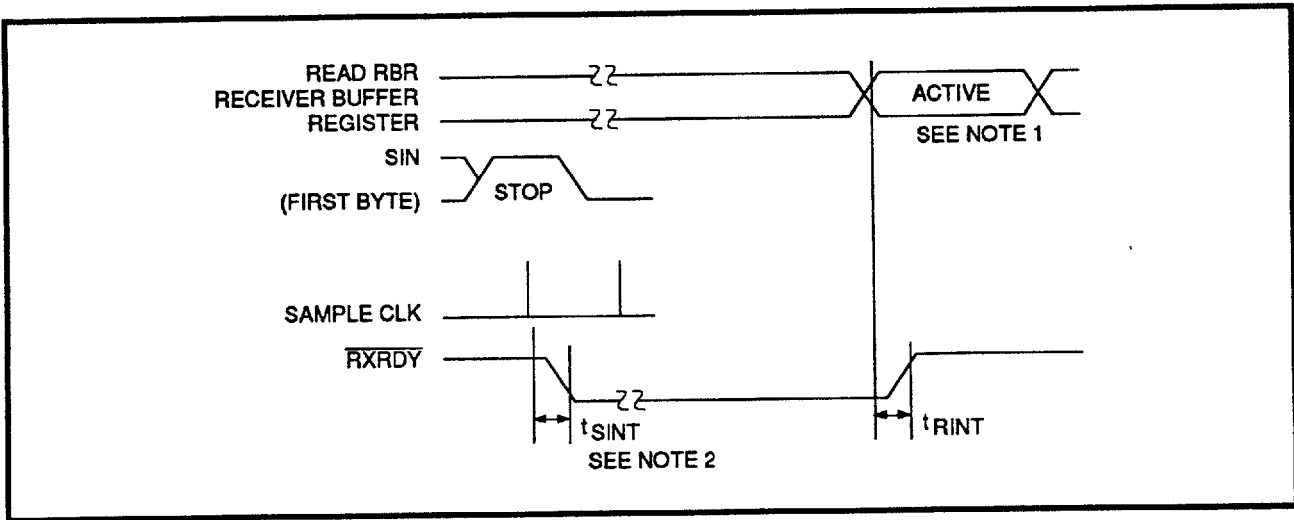

FIGURE 14: Receiver Ready (Pin 29) FCR D0 = 0 or FCR D0 = 1 and FCR D3 = 0 (Mode 0)

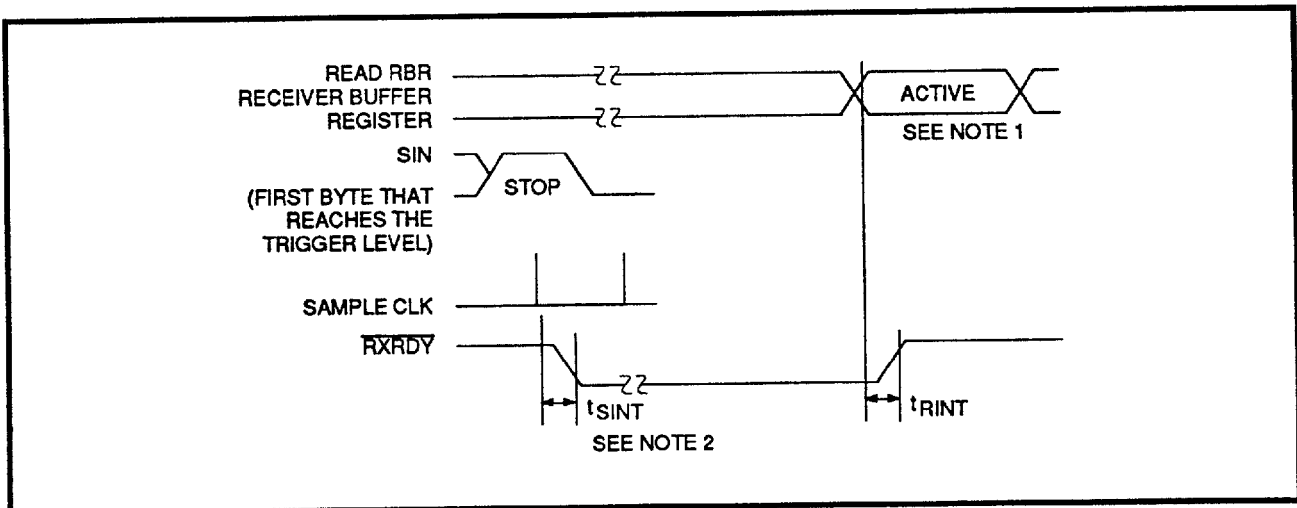

FIGURE 15: Receiver Ready (Pin 29) FCR D0 = 1 and FCR D3 = 1 (Mode 1)

Note 1: This is the reading of the last byte in the FIFO

Note 2: If FCR D0 = 1, then $t_{SINT} = 3 \text{ RCLKs}$. For a timeout interrupt, $t_{SINT} = 8 \text{ RCLKs}$.

Note 3: READ occurs when both read ($\overline{\text{RD}}$, $\overline{\text{RD}}$) and chip select (CS0 , CS1 , $\overline{\text{CS2}}$, latched by $\overline{\text{ADS}}$) are asserted.

SSI 73M550 SSI 73M1550/2550 UART with FIFOs

SSI 73M550 TIMING COMPARED TO PCMCIA PC CARD STANDARD - RELEASE 2.0

ITEM	SYMBOL	IEEE	MIN	MAX	SSI 73M550			
					SSI	MIN	MAX	UNITS
Data Setup before IOWR	t _{su} (IOWR)	tDVIWL	60		TDS	30		ns
Data Hold following IOWR	t _h (IOWR)	tIWHDX	30		TDH	30		ns
IOWR Width Time	t _w IOWR	tIWLWH	165		TWR	80		ns
Address Setup before IOWR	t _{su} A (IOWR)	tAVIWL	70		TAW	30		ns
Address Hold following IOWR	t _h A (IOWR)	tIWHAX	20		TWA	20		ns
CE Setup before IOWR	t _{su} CE (IOWR)	tELIWL	5			Any		
CE Hold following IOWR	t _h CE (IOWR)	tIWHHEH	20			Any		
REG Setup before IOWR	t _{su} REG (IOWR)	tRGLIWL	5					
REG Hold following IOWR	t _h REG (IOWR)	tIWHRGH	0					
IOIS16 Delay Falling from Address	t _d IOIS16 (ADR) ₁	tAVISL		35				
IOIS16 Delay Rising from Address	t _d IOIS16 (ADR) ₂	tAVISH		35				
Wait Delay Falling from IOWR	t _d WAIT (IOWR)	tIWLWTL		35				
Wait Width Time	t _w WAIT	tIWLWTH		12,000				

NOTE: The maximum load on WAIT, INPACK and IOIS16 are 1 LSTTL with 50 pF total load.

TABLE 6: I/O Output (WRITE) Timing Specification for All 5V I/O Cards

SSI 73M550

SSI 73M1550/2550

UART with FIFOs

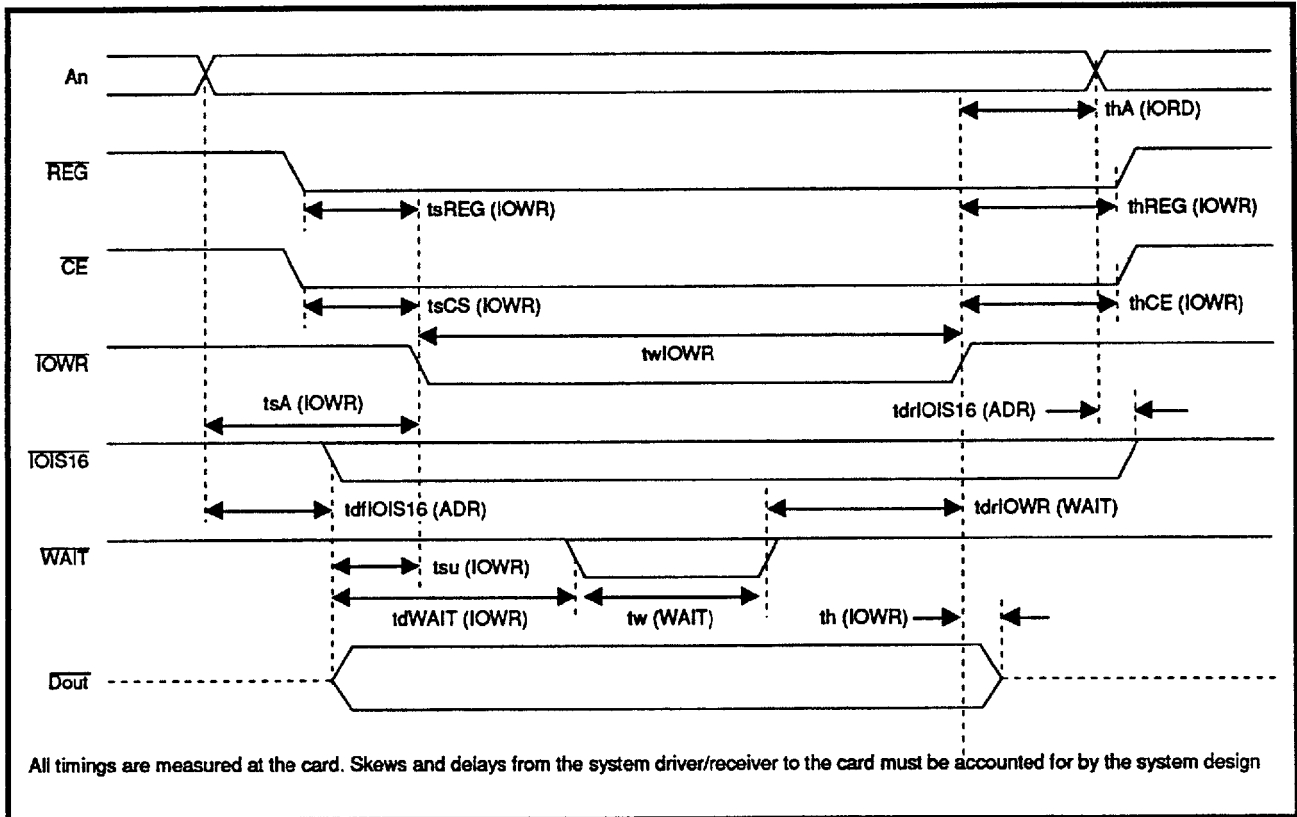

FIGURE 16: I/O Output Timing Specification (WRITE)

SSI 73M550 SSI 73M1550/2550 UART with FIFOs

SSI 73M550 TIMING COMPARED TO PCMCIA PC CARD STANDARD - RELEASE 2.0

ITEM	SYMBOL	IEEE	MIN	MAX	SSI 73M550			
					SSI	MIN	MAX	UNITS
Data Delay after IORD	t d (IORD)	tIGLQV		100	TRVD		80	ns
Data Hold following IORD	t h (IORD)	tIGHQX	0		THZ	0		ns
IORD Width Time	t w IORD	tIGLIGH	165		TRD	80		ns
Address Setup before IORD	t su A (IORD)	tAVIGL	70		TAR	30		ns
Address Hold following IORD	t h A (IORD)	tIGHAX	20		TRA	20		ns
CE Setup before IORD	t su CE (IORD)	tELIGL	5			Any		
CE Hold following IORD	t h CE (IORD)	tIGHEH	20			Any		
REG Setup before IORD	t su REG (IORD)	tRGLIGL	5					
REG Hold following IORD	t h REG (IORD)	tIGHRGH	0					
INPACK Delay Falling from IORD	t d INPACK (IORD)	tGLIAL	0	45				
INPACK Delay Rising from IORD	t d INPACK (IORD)	tIGHIAH		45				
IOIS16 Delay Falling from Address	t d IOIS16 (ADR) ₁	tAVISL		35				
IOIS16 Delay Rising from Address	t d IOIS16 (ADR) ₂	tAVISH		35				
Wait Delay Falling from IORD	t d WAIT (IORD)	tIGLWTL		35				
Data Delay from Wait Rising	td(WAIT)	tWTHQV		35				
Wait Width Time	t w WAIT	tWLWTH		12,000				

NOTE: The maximum load on WAIT, INPACK and IOIS16 are 1 LSTTL with 50 pF total load.

TABLE 7: I/O Output (READ) Timing Specification for All 5V I/O Cards

SSI 73M550

SSI 73M1550/2550

UART with FIFOs

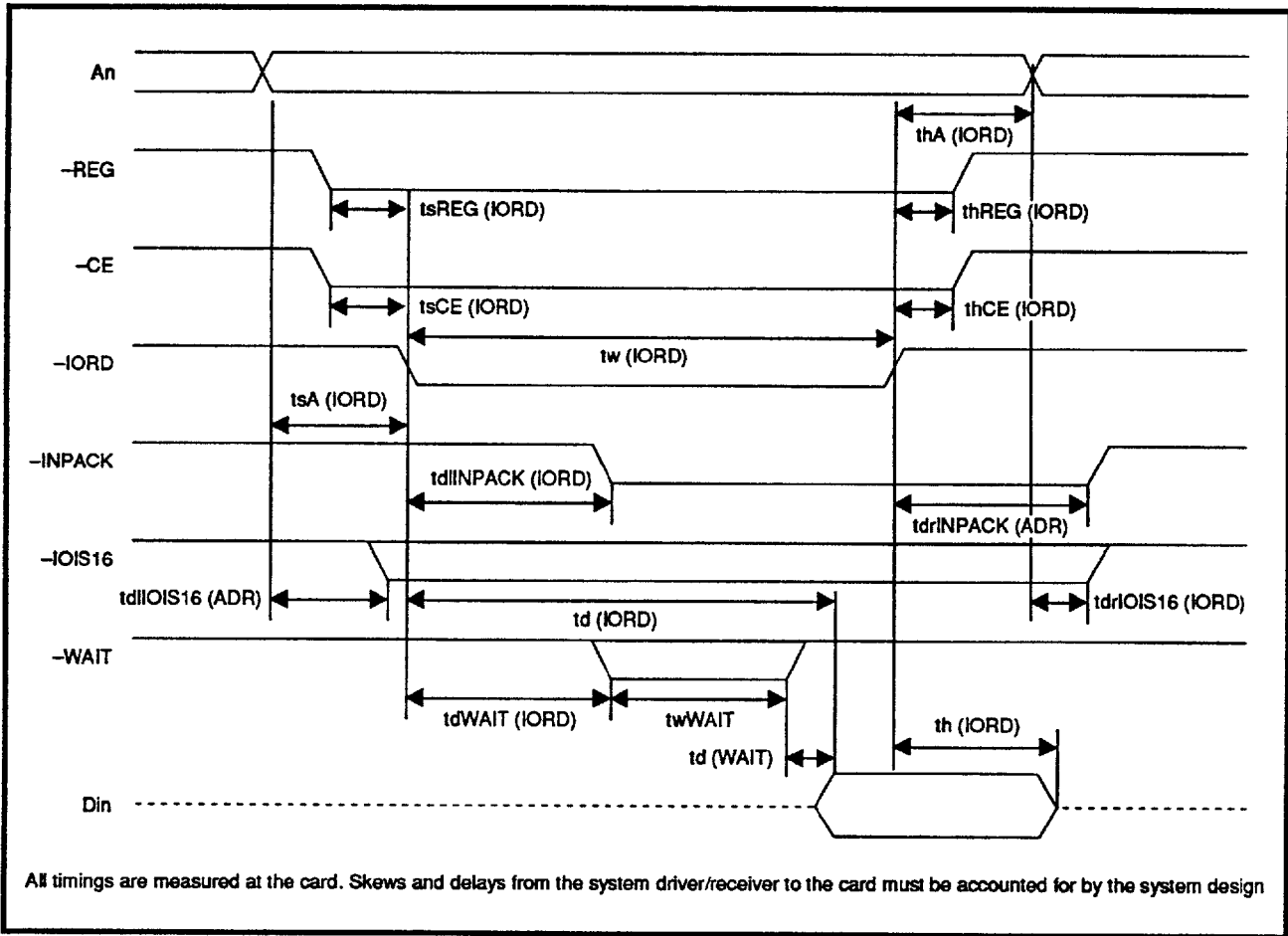

FIGURE 17: I/O Output Timing Specification (READ)

SSI 73M550 SSI 73M1550/2550 UART with FIFOs

APPLICATIONS INFORMATION

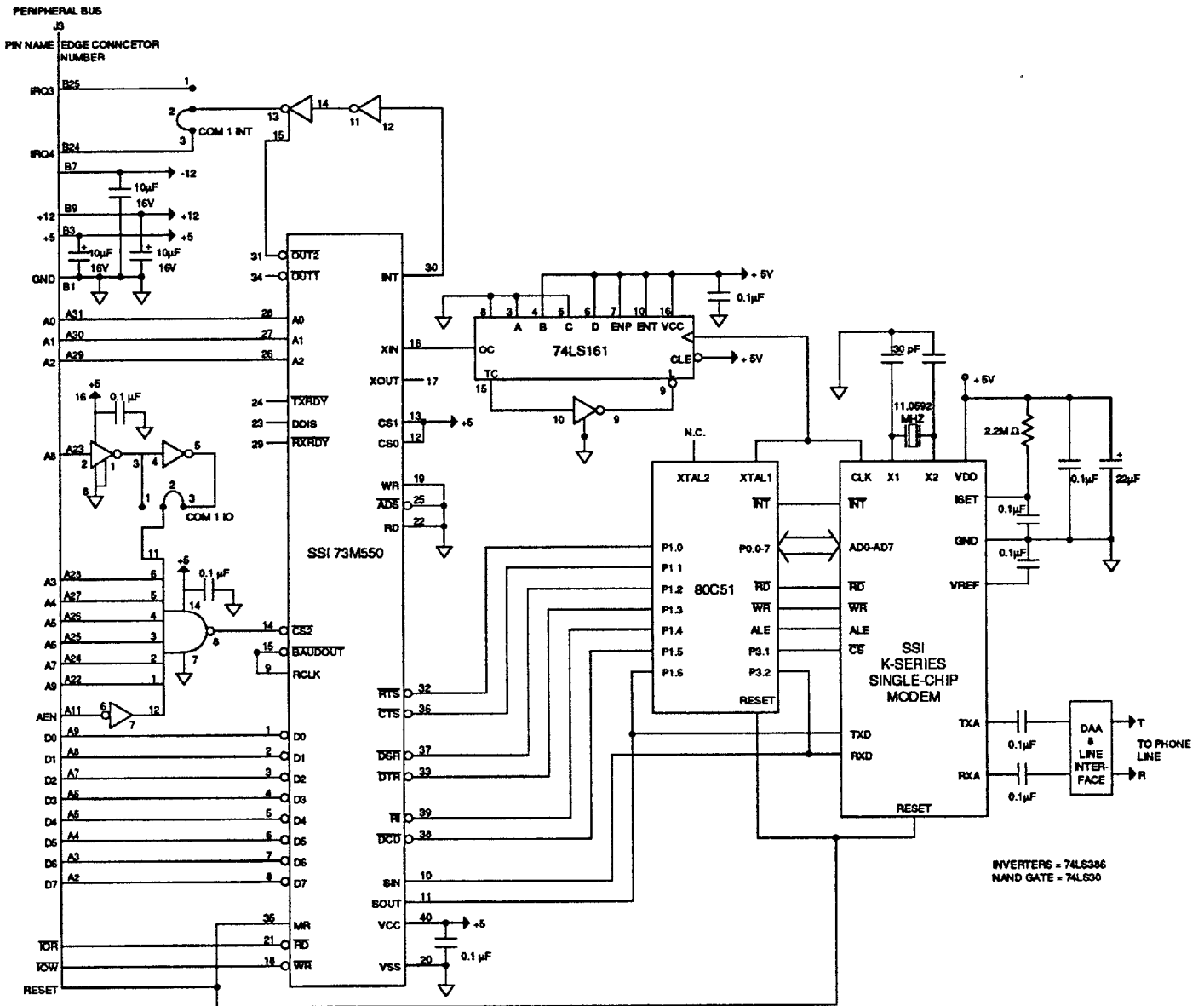

FIGURE 18: Typical Application Showing Modem Interface to Peripheral-Bus via SSI 73M550 UART

SSI 73M550

SSI 73M1550/2550

UART with FIFOs

APPLICATIONS INFORMATION (Continued)

28-PIN VERSION

The 73M550 is available in two 28-pin configurations: SSI 73M1550 and SSI 73M2550. The relation between these two products and the 40-pin version is shown in the accompanying diagram. Note that the only difference between the 73M1550 and 73M2550 is that the 73M2550 adds the μ PRST pin at the expense of the XOUT pin.

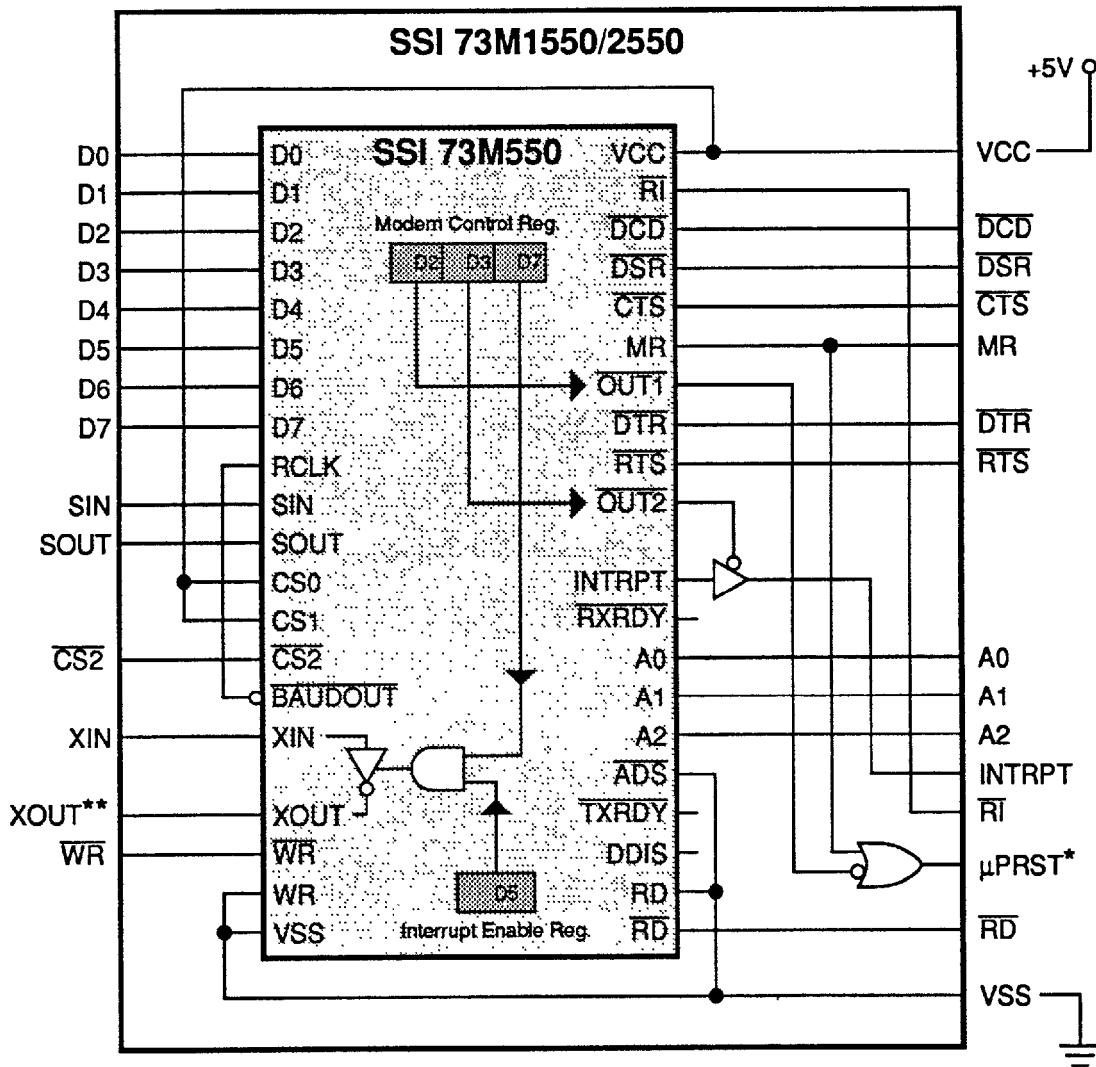

*SSI 73M2550 only.

**SSI 73M1550 only.

FIGURE 19: Adapter Diagram Showing Internal Connections and Bond-outs from 40-pin to 28-pin Packages

SSI 73M550

SSI 73M1550/2550

UART with FIFOs

PACKAGE PIN DESIGNATIONS (Top View)

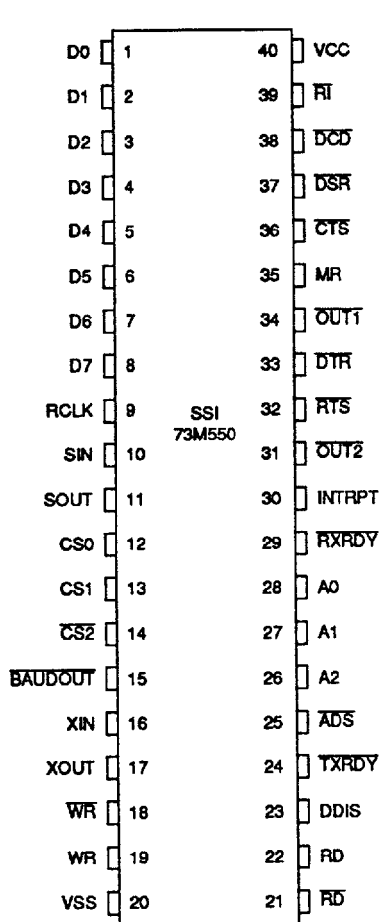

SSI 73M550 40-Pin DIP

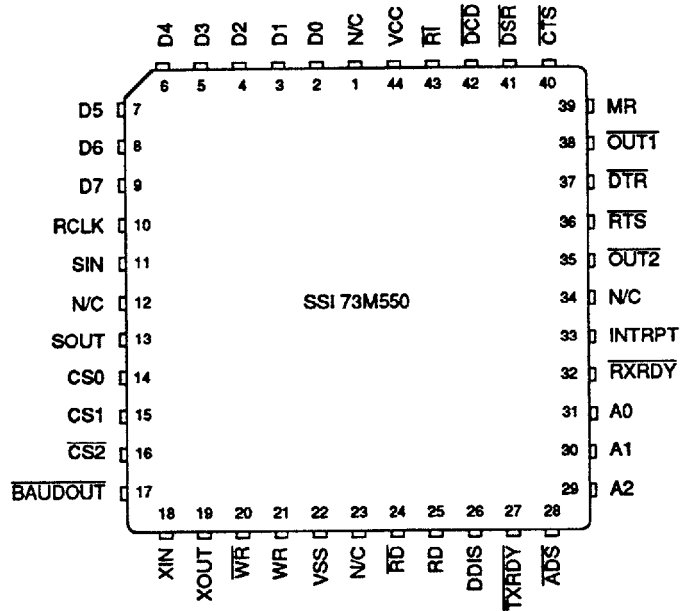

SSI 73M550 44-Pin PLCC

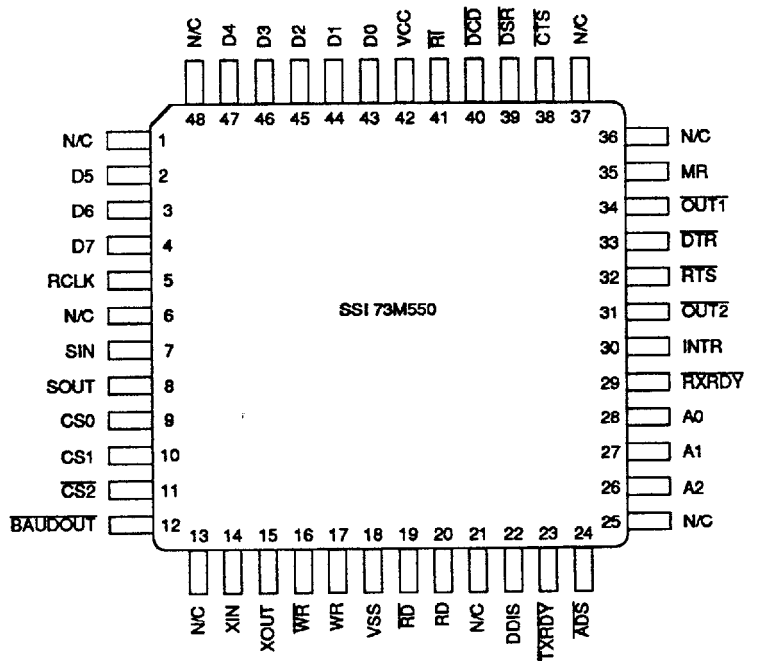

SSI 73M550 48-Lead TQFP

SSI 73M550

SSI 73M1550/2550

UART with FIFOs

PACKAGE PIN DESIGNATIONS (continued)

(Top View)

CAUTION: Use handling procedures necessary for a static sensitive component.

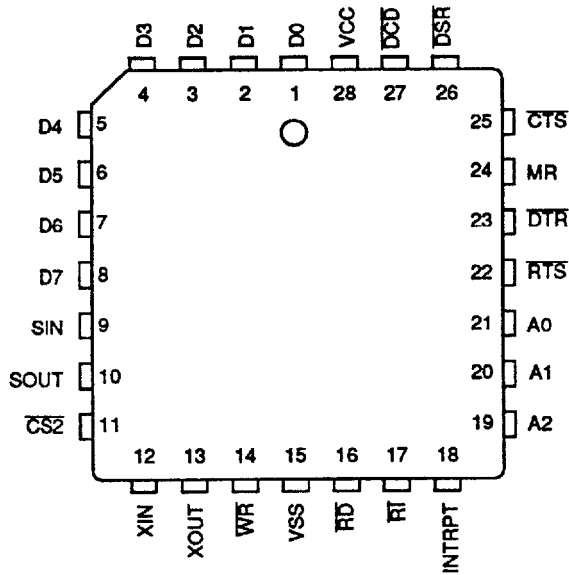

SSI 73M1550 UART
28-Pin PLCC

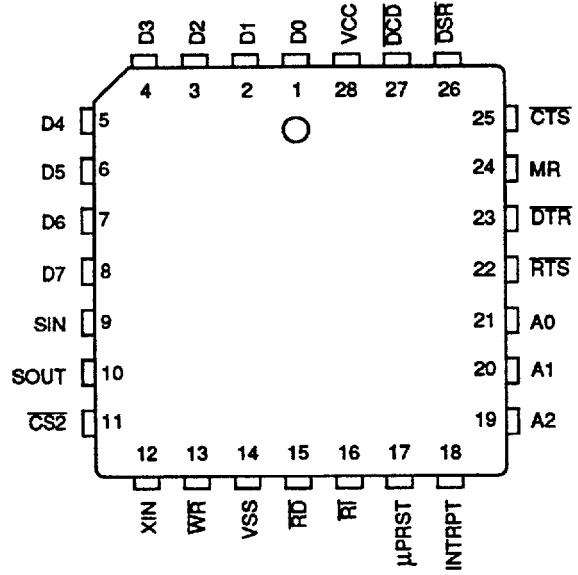

SSI 73M2550 UART
28-Pin PLCC

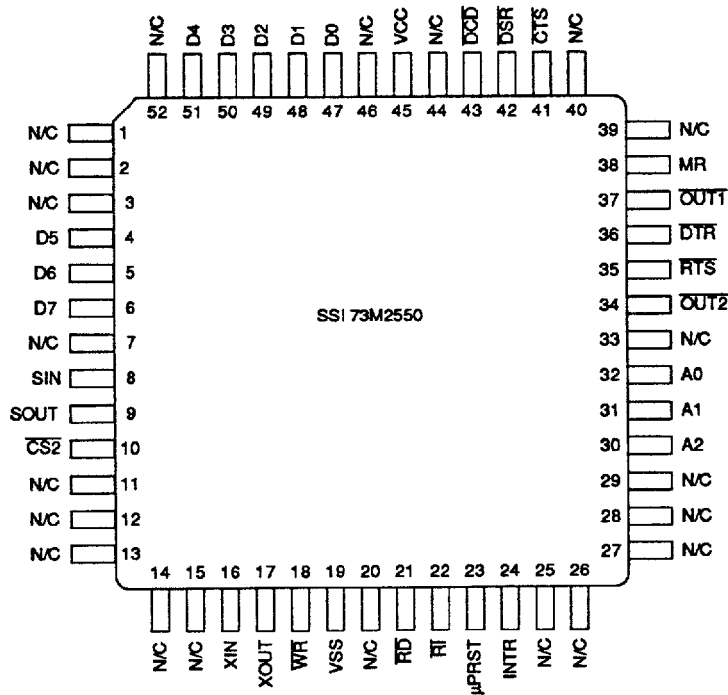

SSI 73M2550 52-Lead QFP

SSI 73M550 SSI 73M1550/2550 UART with FIFOs

CAUTION: Use handling procedures necessary for a static sensitive component.

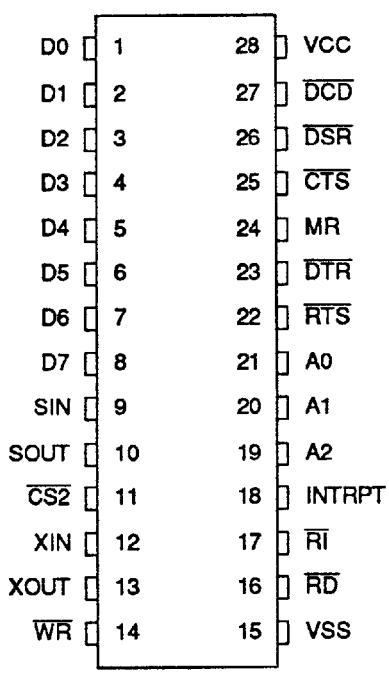

**SSI 73M1550 UART
28-Pin DIP**

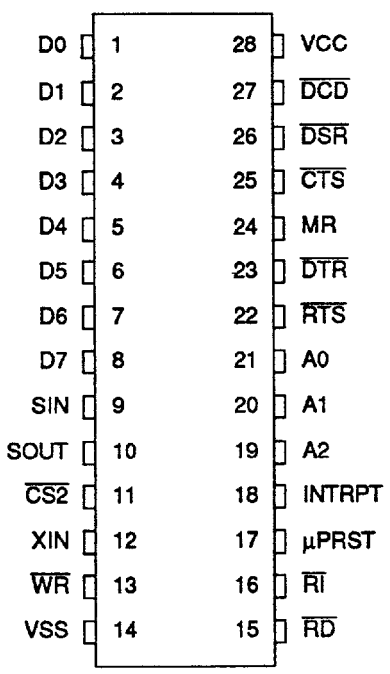

**SSI 73M2550 UART
28-Pin DIP**

ORDERING INFORMATION

PART DESCRIPTION	ORDER NUMBER	PACKAGE MARK
SSI 73M550 40-pin PDIP	73M550-IP	73M550-IP
44-pin PLCC	73M550-IH	73M550-IH
48-lead TQFP	73M550-IGT	73M550-IGT
SSI 73M1550 28-pin DIP	73M1550-IP	73M1550-IP
SSI 73M1550 28-pin PLCC	73M1550-IH	73M1550-IH
SSI 73M2550 28-pin PLCC	73M2550-IH	73M2550-IH
28-pin DIP	73M2550-IP	73M2550-IP
52-lead QFP	73M2550-IG	73M2550-IG

No responsibility is assumed by Silicon Systems for use of this product nor for any infringements of patents and trademarks or other rights of third parties resulting from its use. No license is granted under any patents, patent rights or trademarks of Silicon Systems. Silicon Systems reserves the right to make changes in specifications at any time without notice. Accordingly, the reader is cautioned to verify that the data sheet is current before placing orders.

Silicon Systems, Inc., 14351 Myford Road, Tustin, CA 92680-7022 (714) 573-6000, FAX (714) 573-6914

