

SN74LS155

DUAL 1-OF-4 DECODER/ DEMULTIPLEXER

The SN54/74LS156 is a high speed Dual 1-of-4 Decoder/Demultiplexer. This device has two decoders with common 2-bit Address inputs and separate gated Enable inputs. Decoder "a" has an Enable gate with one active HIGH and one active LOW input. Decoder "b" has two active LOW Enable inputs. If the Enable functions are satisfied, one output of each decoder will be LOW as selected by the address inputs. The LS156 has open collector outputs for wired-OR (DOT-AND) decoding and function generator applications.

The LS156 is fabricated with the Schottky barrier diode process for high speed and are completely compatible with all Motorola TTL families.

- Schottky Process for High Speed
- Multifunction Capability
- Common Address Inputs
- True or Complement Data Demultiplexing
- Input Clamp Diodes Limit High Speed Termination Effects
- ESD > 3500 Volts

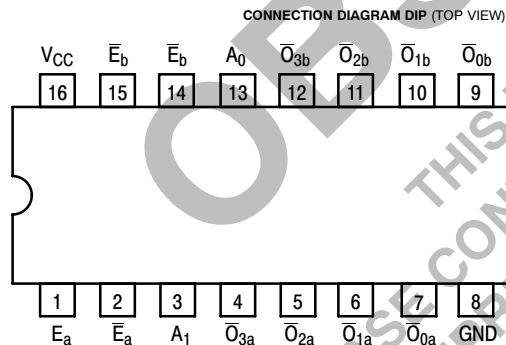

NOTE:
The Flatpak version has the same pinouts (Connection Diagram) as the Dual In-Line Package.



ON Semiconductor®

<http://onsemi.com>

DUAL 1-OF-4 DECODER/ DEMULTIPLEXER LS156-OPEN-COLLECTOR LOW POWER SCHOTTKY

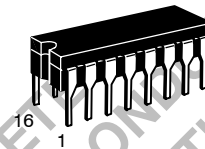

J SUFFIX
CERAMIC
CASE 620-09

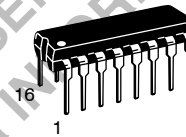

N SUFFIX
PLASTIC
CASE 648-08

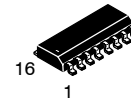

D SUFFIX
SOIC
CASE 751B-03

ORDERING INFORMATION

SN54LSXXXJ	Ceramic
SN74LSXXXN	Plastic
SN74LSXXXD	SOIC

LOGIC SYMBOL

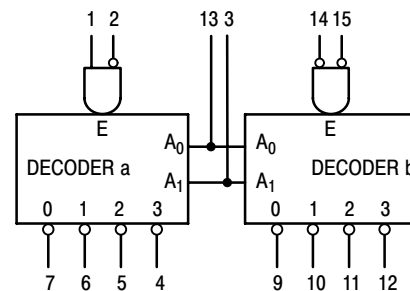

V_{CC} = PIN 16
GND = PIN 8

PIN NAMES

A ₀ , A ₁	Address Inputs
\bar{E}_a , \bar{E}_b	Enable (Active LOW) Inputs
E _a	Enable (Active HIGH) Input
O ₀ –O ₃	Active LOW Outputs (Note b)

LOADING (Note a)

HIGH	LOW
0.5 U.L.	0.25 U.L.
0.5 U.L.	0.25 U.L.
0.5 U.L.	0.25 U.L.
10 U.L.	5 (2.5) U.L.

NOTES:

- 1 TTL Unit Load (U.L.) = 40 μ A HIGH/1.6 mA LOW.
- The Output LOW drive factor is 2.5 U.L. for Military (54) and 5 U.L. for Commercial (74) Temperature Ranges. The HIGH level drive for the LS156 must be established by an external resistor.

SN74LS155

SN54/74LS156

LOGIC DIAGRAM

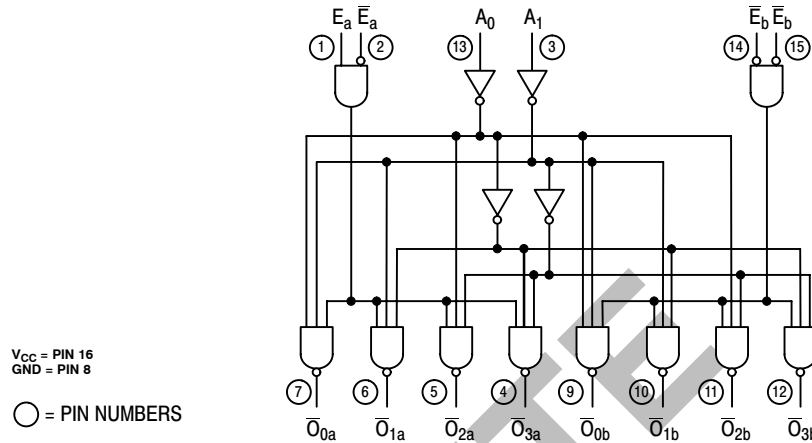

FUNCTIONAL DESCRIPTION

The LS156 is a Dual 1-of-4 Decoder/Demultiplexer with common Address inputs and separate gated Enable inputs. When enabled, each decoder section accepts the binary weighted Address inputs (A_0, A_1) and provides four mutually exclusive active LOW outputs ($\bar{O}_0 - \bar{O}_3$). If the Enable requirements of each decoder are not met, all outputs of that decoder are HIGH.

Each decoder section has a 2-input enable gate. The enable gate for Decoder "a" requires one active HIGH input and one active LOW input ($E_a \cdot \bar{E}_a$). In demultiplexing applications, Decoder "a" can accept either true or complemented data by using the \bar{E}_a or E_a inputs respectively. The enable gate for Decoder "b" requires two active LOW inputs ($\bar{E}_b \cdot \bar{E}_b$). The LS155 or LS156 can be used as a 1-of-8 Decoder/Demultiplexer by tying E_a to \bar{E}_b and relabeling the common connection as (A_2). The other \bar{E}_b and \bar{E}_a are connected together to form the common enable.

The LS156 can be used to generate all four minterms of two variables. These four minterms are useful in some applications replacing multiple gate functions as shown in Fig. a. The LS156 has the further advantage of being able to

AND the minterm functions by tying outputs together. Any number of terms can be wired-AND as shown below.

$$f = (E + A_0 + A_1) \cdot (E + \bar{A}_0 + A_1) \cdot (E + A_0 + \bar{A}_1) \cdot (E + \bar{A}_0 + \bar{A}_1)$$

$$\text{where } E = E_a + \bar{E}_a; \bar{E} = E_b + \bar{E}_b$$

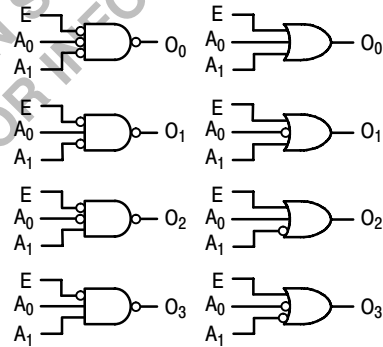

Figure a

TRUTH TABLE

ADDRESS		ENABLE "a"		OUTPUT "a"				ENABLE "b"		OUTPUT "b"			
A ₀	A ₁	E _a	\bar{E}_a	\bar{O}_0	\bar{O}_1	\bar{O}_2	\bar{O}_3	E _b	\bar{E}_b	\bar{O}_0	\bar{O}_1	\bar{O}_2	\bar{O}_3
X	X	L	X	H	H	H	H	H	X	H	H	H	H
X	X	X	H	H	H	H	H	X	H	H	H	H	H
L	L	H	L	L	H	H	H	L	L	L	H	H	H
H	L	H	L	H	L	H	H	L	L	H	L	H	H
L	H	H	L	H	H	L	H	L	L	H	H	L	H
H	H	H	L	H	H	H	L	L	L	H	H	H	L

H = HIGH Voltage Level
L = LOW Voltage Level
X = Don't Care

SN74LS155

SN54/74LS156

GUARANTEED OPERATING RANGES

Symbol	Parameter		Min	Typ	Max	Unit
V _{CC}	Supply Voltage	54 74	4.5 4.75	5.0 5.0	5.5 5.25	V
T _A	Operating Ambient Temperature Range	54 74	-55 0	25 25	125 70	°C
V _{OH}	Output Voltage — High	54, 74			5.5	V
I _{OL}	Output Current — Low	54 74			4.0 8.0	mA

DC CHARACTERISTICS OVER OPERATING TEMPERATURE RANGE (unless otherwise specified)

Symbol	Parameter	Limits			Unit	Test Conditions
		Min	Typ	Max		
V _{IH}	Input HIGH Voltage	2.0			V	Guaranteed Input HIGH Voltage for All Inputs
V _{IL}	Input LOW Voltage	54		0.7	V	Guaranteed Input LOW Voltage for All Inputs
		74		0.8		
V _{IK}	Input Clamp Diode Voltage		-0.65	-1.5	V	V _{CC} = MIN, I _{IN} = -18 mA
I _{OH}	Output HIGH Current	54, 74		100	μA	V _{CC} = MIN, V _{OH} = MAX
V _{OL}	Output LOW Voltage	54, 74	0.25	0.4	V	I _{OL} = 4.0 mA V _{CC} = V _{CC} MIN, V _{IN} = V _{IL} or V _{IH} per Truth Table
		74	0.35	0.5	V	
I _{IH}	Input HIGH Current			20	μA	V _{CC} = MAX, V _{IN} = 2.7 V
				0.1	mA	V _{CC} = MAX, V _{IN} = 7.0 V
I _{IL}	Input LOW Current			-0.4	mA	V _{CC} = MAX, V _{IN} = 0.4 V
I _{CC}	Power Supply Current			10	mA	V _{CC} = MAX

AC CHARACTERISTICS (T_A = 25°C)

Symbol	Parameter	Limits			Unit	Test Conditions
		Min	Typ	Max		
t _{PLH} t _{PHL}	Propagation Delay Address, \bar{E}_a or \bar{E}_b to Output		25 34	40 51	ns	V _{CC} = 5.0 V C _L = 15 pF R _L = 2.0 kΩ
t _{PLH} t _{PHL}	Propagation Delay Address to Output		31 34	46 51	ns	
t _{PLH} t _{PHL}	Propagation Delay E _a to Output		32 32	48 48	ns	

AC WAVEFORMS

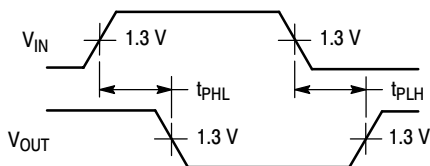

Figure 1

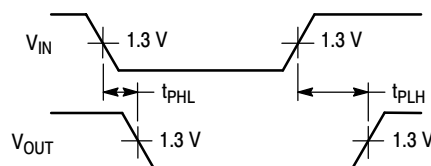

Figure 2

OBSOLETE
 THIS DEVICE IS OBSOLETE
 PLEASE CONTACT YOUR ON SEMICONDUCTOR
 REPRESENTATIVE FOR INFORMATION

ON Semiconductor and **ON** are registered trademarks of Semiconductor Components Industries, LLC (SCILLC). SCILLC reserves the right to make changes without further notice to any products herein. SCILLC makes no warranty, representation or guarantee regarding the suitability of its products for any particular purpose, nor does SCILLC assume any liability arising out of the application or use of any product or circuit, and specifically disclaims any and all liability, including without limitation special, consequential or incidental damages. "Typical" parameters which may be provided in SCILLC data sheets and/or specifications can and do vary in different applications and actual performance may vary over time. All operating parameters, including "Typicals" must be validated for each customer application by customer's technical experts. SCILLC does not convey any license under its patent rights nor the rights of others. SCILLC products are not designed, intended, or authorized for use as components in systems intended for surgical implant into the body, or other applications intended to support or sustain life, or for any other application in which the failure of the SCILLC product could create a situation where personal injury or death may occur. Should Buyer purchase or use SCILLC products for any such unintended or unauthorized application, Buyer shall indemnify and hold SCILLC and its officers, employees, subsidiaries, affiliates, and distributors harmless against all claims, costs, damages, and expenses, and reasonable attorney fees arising out of, directly or indirectly, any claim of personal injury or death associated with such unintended or unauthorized use, even if such claim alleges that SCILLC was negligent regarding the design or manufacture of the part. SCILLC is an Equal Opportunity/Affirmative Action Employer. This literature is subject to all applicable copyright laws and is not for resale in any manner.

PUBLICATION ORDERING INFORMATION

LITERATURE FULFILLMENT:

Literature Distribution Center for ON Semiconductor
 P.O. Box 5163, Denver, Colorado 80217 USA
Phone: 303-675-2175 or 800-344-3860 Toll Free USA/Canada
Fax: 303-675-2176 or 800-344-3867 Toll Free USA/Canada
Email: orderlit@onsemi.com

N. American Technical Support: 800-282-9855 Toll Free
 USA/Canada
Europe, Middle East and Africa Technical Support:
 Phone: 421 33 790 2910
Japan Customer Focus Center
 Phone: 81-3-5773-3850

ON Semiconductor Website: www.onsemi.com
Order Literature: <http://www.onsemi.com/orderlit>

For additional information, please contact your local Sales Representative