

# DATA SHEET

## **74ABT827**

10-bit buffer/line driver, non-inverting  
(3-State)

Product specification  
Supersedes data of 1995 Sep 06  
IC23 Data Handbook

1998 Jan 16

## 10-bit buffer/line driver, non-inverting (3-State)

## 74ABT827

## FEATURES

- Ideal where high speed, light loading, or increased fan-in are required
- Flow through pinout architecture for microprocessor oriented applications
- Output capability: +64mA/–32mA
- Slim 300 mil-wide plastic 24-pin package
- Latch-up protection exceeds 500mA per Jedec Std 17
- ESD protection exceeds 2000 V per MIL STD 883 Method 3015 and 200 V per Machine Model
- Power-up 3-State
- Inputs are disabled during 3-State mode

## DESCRIPTION

The 74ABT827 high-performance BiCMOS device combines low static and dynamic power dissipation with high speed and high output drive.

The 74ABT827 10-bit buffers provide high performance bus interface buffering for wide data/address paths or buses carrying parity. They have NOR Output Enables ( $\overline{OE}0$ ,  $\overline{OE}1$ ) for maximum control flexibility.

## QUICK REFERENCE DATA

SYMBOL	PARAMETER	CONDITIONS $T_{amb} = 25^{\circ}\text{C}; \text{GND} = 0\text{V}$	TYPICAL	UNIT
$t_{PLH}$ $t_{PHL}$	Propagation delay An to Yn	$C_L = 50\text{pF}; V_{CC} = 5\text{V}$	3.0	ns
$C_{IN}$	Input capacitance	$V_I = 0\text{V}$ or $V_{CC}$	4	pF
$C_{OUT}$	Output capacitance	Outputs disabled; $V_O = 0\text{V}$ or $V_{CC}$	7	pF
$I_{CCZ}$	Total supply current	Outputs disabled; $V_{CC} = 5.5\text{V}$	500	nA

## ORDERING INFORMATION

PACKAGES	TEMPERATURE RANGE	OUTSIDE NORTH AMERICA	NORTH AMERICA	DWG NUMBER
24-Pin Plastic DIP	–40°C to +85°C	74ABT827 N	74ABT827 N	SOT222-1
24-Pin plastic SO	–40°C to +85°C	74ABT827 D	74ABT827 D	SOT137-1
24-Pin Plastic SSOP Type II	–40°C to +85°C	74ABT827 DB	74ABT827 DB	SOT340-1
24-Pin Plastic TSSOP Type I	–40°C to +85°C	74ABT827 PW	74ABT827PW DH	SOT355-1

# 10-bit buffer/line driver, non-inverting (3-State)

# 74ABT827

## PIN CONFIGURATION

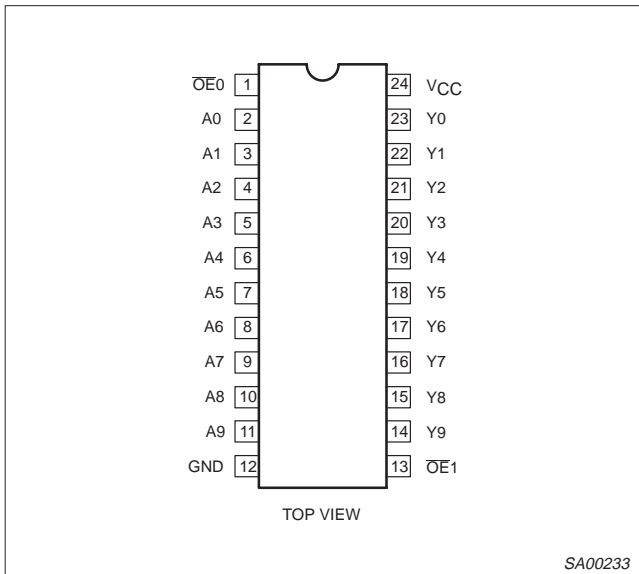

## LOGIC SYMBOL

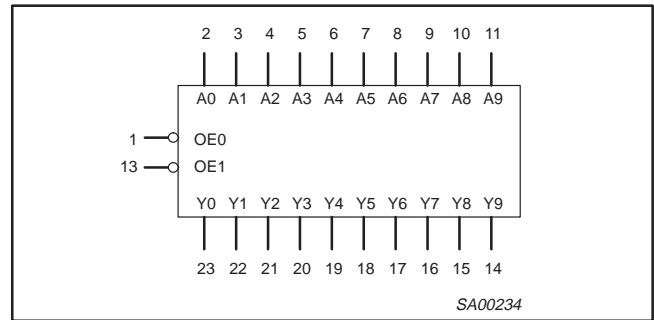

## FUNCTION TABLE

INPUTS		OUTPUTS	OPERATING MODE
OE <sub>n</sub>	A <sub>n</sub>	Y <sub>n</sub>	
L	L	L	Transparent
L	H	H	Transparent
H	X	Z	High impedance

- H = High voltage level
- L = Low voltage level
- X = Don't care
- Z = High impedance "off" state

## PIN DESCRIPTION

PIN NUMBER	SYMBOL	FUNCTION
1, 13	OE <sub>0</sub> , OE <sub>1</sub>	Output enable input (active-Low)
2, 3, 4, 5, 6, 7, 8, 9, 10, 11	A <sub>0</sub> -A <sub>9</sub>	Data inputs
23, 22, 21, 20, 19, 18, 17, 16, 15, 14	Y <sub>0</sub> -Y <sub>9</sub>	Data outputs
10	GND	Ground (0V)
20	V <sub>CC</sub>	Positive supply voltage

## LOGIC SYMBOL (IEEE/IEC)

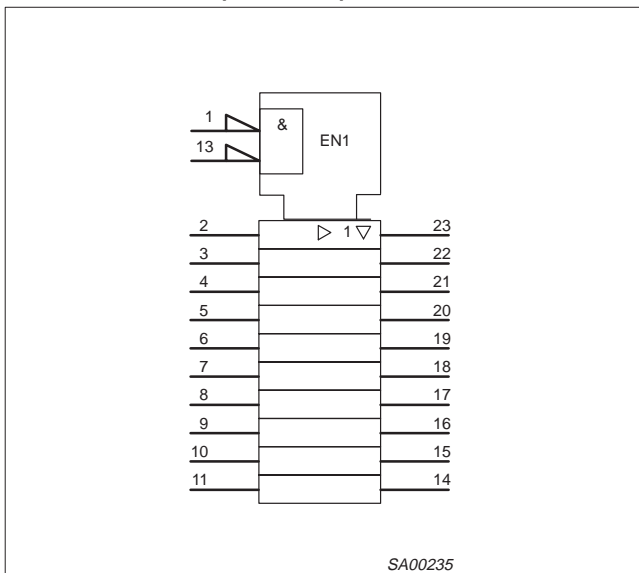

# 10-bit buffer/line driver, non-inverting (3-State)

74ABT827

## LOGIC DIAGRAM

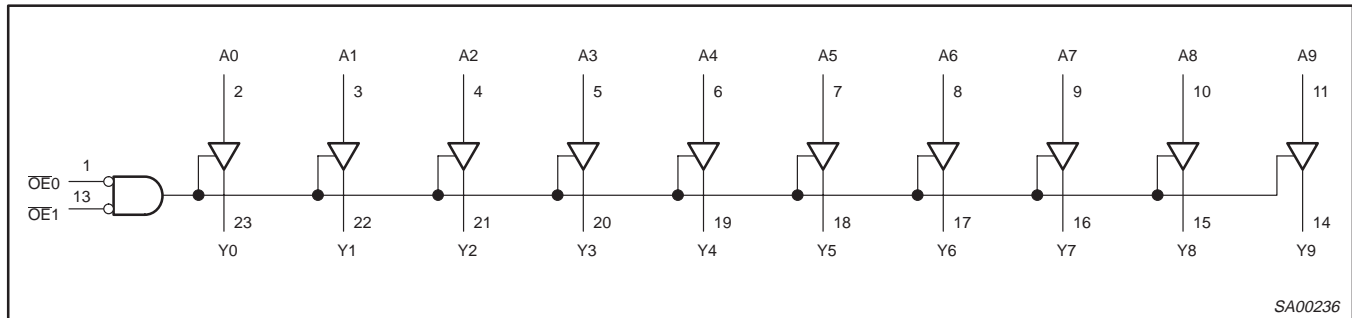

## ABSOLUTE MAXIMUM RATINGS<sup>1, 2</sup>

SYMBOL	PARAMETER	CONDITIONS	RATING	UNIT
$V_{CC}$	DC supply voltage		-0.5 to +7.0	V
$I_{IK}$	DC input diode current	$V_I < 0$	-18	mA
$V_I$	DC input voltage <sup>3</sup>		-1.2 to +7.0	V
$I_{OK}$	DC output diode current	$V_O < 0$	-50	mA
$V_{OUT}$	DC output voltage <sup>3</sup>	output in Off or High state	-0.5 to +5.5	V
$I_{OUT}$	DC output current	output in Low state	128	mA
$T_{stg}$	Storage temperature range		-65 to 150	°C

### NOTES:

1. Stresses beyond those listed may cause permanent damage to the device. These are stress ratings only and functional operation of the device at these or any other conditions beyond those indicated under "recommended operating conditions" is not implied. Exposure to absolute-maximum-rated conditions for extended periods may affect device reliability.
2. The performance capability of a high-performance integrated circuit in conjunction with its thermal environment can create junction temperatures which are detrimental to reliability. The maximum junction temperature of this integrated circuit should not exceed 150°C.
3. The input and output voltage ratings may be exceeded if the input and output current ratings are observed.

## RECOMMENDED OPERATING CONDITIONS

SYMBOL	PARAMETER	LIMITS		UNIT
		Min	Max	
$V_{CC}$	DC supply voltage	4.5	5.5	V
$V_I$	Input voltage	0	$V_{CC}$	V
$V_{IH}$	High-level input voltage	2.0		V
$V_{IL}$	Low-level input voltage		0.8	V
$I_{OH}$	High-level output current		-32	mA
$I_{OL}$	Low-level output current		64	mA
$\Delta t/\Delta v$	Input transition rise or fall rate	0	5	ns/V
$T_{amb}$	Operating free-air temperature range	-40	+85	°C

## 10-bit buffer/line driver, non-inverting (3-State)

74ABT827

## DC ELECTRICAL CHARACTERISTICS

SYMBOL	PARAMETER	TEST CONDITIONS	LIMITS					UNIT
			T <sub>amb</sub> = +25°C			T <sub>amb</sub> = -40°C to +85°C		
			Min	Typ	Max	Min	Max	
V <sub>IK</sub>	Input clamp voltage	V <sub>CC</sub> = 4.5V; I <sub>IK</sub> = -18mA		-0.9	-1.2		-1.2	V
V <sub>OH</sub>	High-level output voltage	V <sub>CC</sub> = 4.5V; I <sub>OH</sub> = -3mA; V <sub>I</sub> = V <sub>IL</sub> or V <sub>IH</sub>	2.5	2.9		2.5		V
		V <sub>CC</sub> = 5.0V; I <sub>OH</sub> = -3mA; V <sub>I</sub> = V <sub>IL</sub> or V <sub>IH</sub>	3.0	3.4		3.0		V
		V <sub>CC</sub> = 4.5V; I <sub>OH</sub> = -32mA; V <sub>I</sub> = V <sub>IL</sub> or V <sub>IH</sub>	2.0	2.4		2.0		V
V <sub>OL</sub>	Low-level output voltage	V <sub>CC</sub> = 4.5V; I <sub>OL</sub> = 64mA; V <sub>I</sub> = V <sub>IL</sub> or V <sub>IH</sub>		0.42	0.55		0.55	V
I <sub>I</sub>	Input leakage current	V <sub>CC</sub> = 5.5V; V <sub>I</sub> = GND or 5.5V		±0.01	±1.0		±1.0	µA
I <sub>OFF</sub>	Power-off leakage current	V <sub>CC</sub> = 0.0V; V <sub>O</sub> or V <sub>I</sub> ≤ 4.5V		±5.0	±100		±100	µA
I <sub>PU</sub> /I <sub>PD</sub>	Power-up/down 3-State output current <sup>3</sup>	V <sub>CC</sub> = 2.0V; V <sub>O</sub> = 0.5V; V <sub>I</sub> = GND or V <sub>CC</sub> ; V <sub>OE</sub> = V <sub>CC</sub>		±5.0	±50		±50	µA
I <sub>OZH</sub>	3-State output High current	V <sub>CC</sub> = 5.5V; V <sub>O</sub> = 2.7V; V <sub>I</sub> = V <sub>IL</sub> or V <sub>IH</sub>		5.0	50		50	µA
I <sub>OZL</sub>	3-State output Low current	V <sub>CC</sub> = 5.5V; V <sub>O</sub> = 0.5V; V <sub>I</sub> = V <sub>IL</sub> or V <sub>IH</sub>		-5.0	-50		-50	µA
I <sub>CEX</sub>	Output High leakage current	V <sub>CC</sub> = 5.5V; V <sub>O</sub> = 5.5V; V <sub>I</sub> = GND or V <sub>CC</sub>		5.0	50		50	µA
I <sub>O</sub>	Output current <sup>1</sup>	V <sub>CC</sub> = 5.5V; V <sub>O</sub> = 2.5V	-50	-80	-180	-50	-180	mA
I <sub>CCH</sub>	Quiescent supply current	V <sub>CC</sub> = 5.5V; Outputs High, V <sub>I</sub> = GND or V <sub>CC</sub>		0.5	250		250	µA
I <sub>CCL</sub>		V <sub>CC</sub> = 5.5V; Outputs Low, V <sub>I</sub> = GND or V <sub>CC</sub>		25	38		38	mA
I <sub>CCZ</sub>		V <sub>CC</sub> = 5.5V; Outputs 3-State; V <sub>I</sub> = GND or V <sub>CC</sub>		0.5	250		250	µA
ΔI <sub>CC</sub>	Additional supply current per input pin <sup>2</sup>	Outputs enabled, one input at 3.4V, other inputs at V <sub>CC</sub> or GND; V <sub>CC</sub> = 5.5V		0.5	1.5		1.5	mA
		Outputs 3-State, one data input at 3.4V, other inputs at V <sub>CC</sub> or GND; V <sub>CC</sub> = 5.5V		0.01	50		50	mA
		Outputs 3-State, one enable input at 3.4V, other inputs at V <sub>CC</sub> or GND; V <sub>CC</sub> = 5.5V		0.5	1.5		1.5	mA

## NOTES:

- Not more than one output should be tested at a time, and the duration of the test should not exceed one second.
- This is the increase in supply current for each input at 3.4V.
- This parameter is valid for any V<sub>CC</sub> between 0V and 2.1V with a transition time of up to 10msec. For V<sub>CC</sub> = 2.1V to V<sub>CC</sub> = 5V ± 10%, a transition time of up to 100µsec is permitted.

# 10-bit buffer/line driver, non-inverting (3-State)

74ABT827

## AC CHARACTERISTICS

GND = 0V,  $t_R = t_F = 2.5\text{ns}$ ,  $C_L = 50\text{pF}$ ,  $R_L = 500\Omega$

SYMBOL	PARAMETER	WAVEFORM	LIMITS					UNIT
			$T_{\text{amb}} = +25^\circ\text{C}$ $V_{\text{CC}} = +5.0\text{V}$			$T_{\text{amb}} = -40$ to $+85^\circ\text{C}$ $V_{\text{CC}} = +5.0\text{V} \pm 0.5\text{V}$		
			Min	Typ	Max	Min	Max	
$t_{\text{PLH}}$ $t_{\text{PHL}}$	Propagation delay An to Yn	1	1.1 1.1	3.0 2.9	4.4 4.1	1.1 1.1	4.8 4.7	ns
$t_{\text{PZH}}$ $t_{\text{PZL}}$	Output enable time to High and Low level	2	1.6 2.6	3.7 4.6	5.1 5.9	1.6 2.6	5.9 6.9	ns
$t_{\text{PHZ}}$ $t_{\text{PLZ}}$	Output disable time from High and Low level	2	2.0 2.5	4.8 5.1	6.3 6.6	2.0 2.5	6.8 6.9	ns

## AC WAVEFORMS

$V_M = 1.5\text{V}$ ,  $V_{\text{IN}} = \text{GND to } 3.0\text{V}$

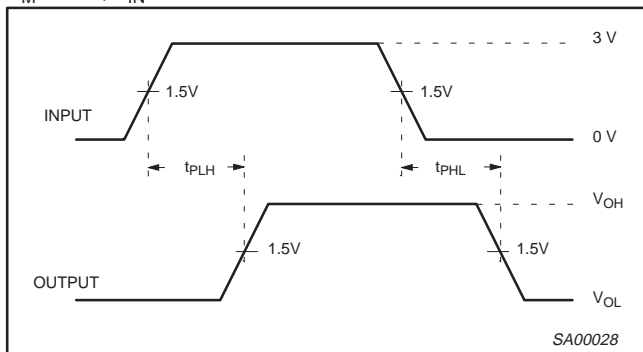

Waveform 1. Waveforms Showing the Input (An) to Output (Yn) Propagation Delays

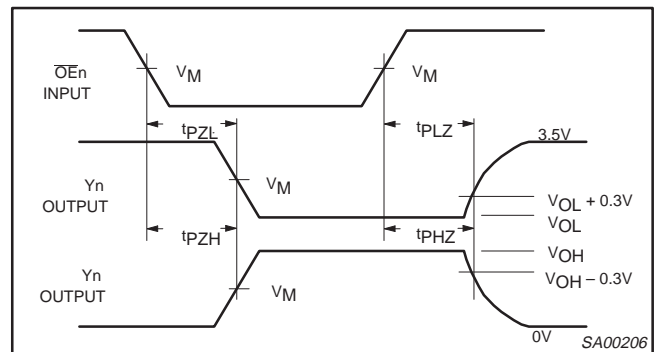

Waveform 2. Waveforms Showing the 3-State Output Enable and Disable Times

## TEST CIRCUIT AND WAVEFORM

**Load Circuit**

TEST	S1
$t_{\text{pd}}$	open
$t_{\text{PLZ}}/t_{\text{PZL}}$	7 V
$t_{\text{PHZ}}/t_{\text{PZH}}$	open

**DEFINITIONS**  
 $C_L =$  Load capacitance includes jig and probe capacitance; see AC CHARACTERISTICS for value.

SA00012

10-bit buffer/line driver, non-inverting (3-State)

74ABT827

DIP24: plastic dual in-line package; 24 leads (300 mil)

SOT222-1

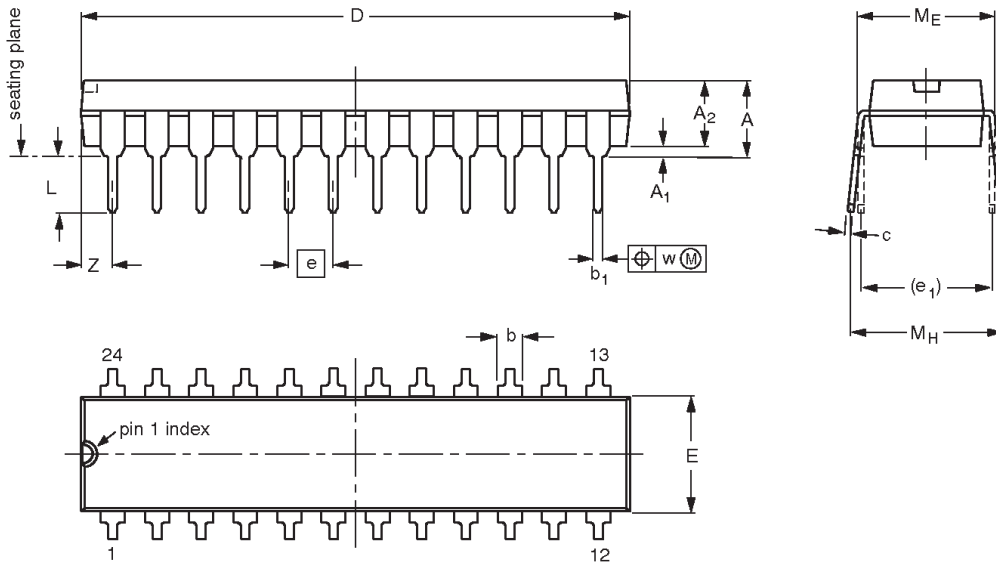

**DIMENSIONS (millimetre dimensions are derived from the original inch dimensions)**

UNIT	A max.	A <sub>1</sub> min.	A <sub>2</sub> max.	b	b <sub>1</sub>	c	D <sup>(1)</sup>	E <sup>(1)</sup>	e	e <sub>1</sub>	L	M <sub>E</sub>	M <sub>H</sub>	w	Z <sup>(1)</sup> max.
mm	4.70	0.38	3.94	1.63 1.14	0.56 0.43	0.36 0.25	31.9 31.5	6.73 6.48	2.54	7.62	3.51 3.05	8.13 7.62	10.03 7.62	0.25	2.05
inches	0.185	0.015	0.155	0.064 0.045	0.022 0.017	0.014 0.010	1.256 1.240	0.265 0.255	0.100	0.300	0.138 0.120	0.32 0.30	0.395 0.300	0.01	0.081

**Note**

1. Plastic or metal protrusions of 0.01 inches maximum per side are not included.

OUTLINE VERSION	REFERENCES				EUROPEAN PROJECTION	ISSUE DATE
	IEC	JEDEC	EIAJ			
SOT222-1		MS-001AF				95-03-11

10-bit buffer/line driver, non-inverting (3-State)

74ABT827

SO24: plastic small outline package; 24 leads; body width 7.5 mm

SOT137-1

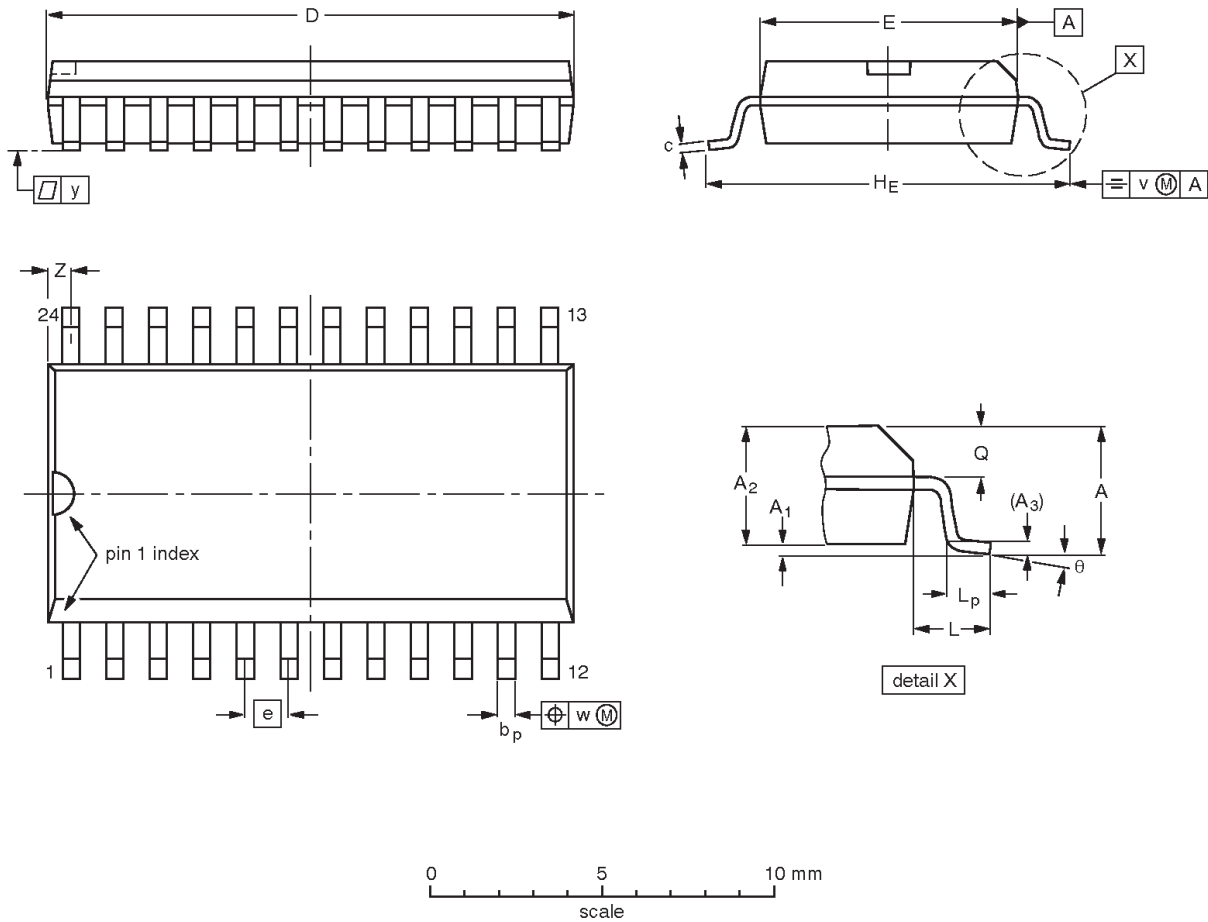

**DIMENSIONS (inch dimensions are derived from the original mm dimensions)**

UNIT	A max.	A <sub>1</sub>	A <sub>2</sub>	A <sub>3</sub>	b <sub>p</sub>	c	D <sup>(1)</sup>	E <sup>(1)</sup>	e	H <sub>E</sub>	L	L <sub>p</sub>	Q	v	w	y	z <sup>(1)</sup>	θ
mm	2.65	0.30 0.10	2.45 2.25	0.25	0.49 0.36	0.32 0.23	15.6 15.2	7.6 7.4	1.27	10.65 10.00	1.4	1.1 0.4	1.1 1.0	0.25	0.25	0.1	0.9 0.4	8° 0°
inches	0.10	0.012 0.004	0.096 0.089	0.01	0.019 0.014	0.013 0.009	0.61 0.60	0.30 0.29	0.050	0.419 0.394	0.055	0.043 0.016	0.043 0.039	0.01	0.01	0.004	0.035 0.016	

**Note**

1. Plastic or metal protrusions of 0.15 mm maximum per side are not included.

OUTLINE VERSION	REFERENCES				EUROPEAN PROJECTION	ISSUE DATE
	IEC	JEDEC	EIAJ			
SOT137-1	075E05	MS-013AD				95-01-24 97-05-22



10-bit buffer/line driver, non-inverting (3-State)

74ABT827

SSOP24: plastic shrink small outline package; 24 leads; body width 5.3 mm

SOT340-1

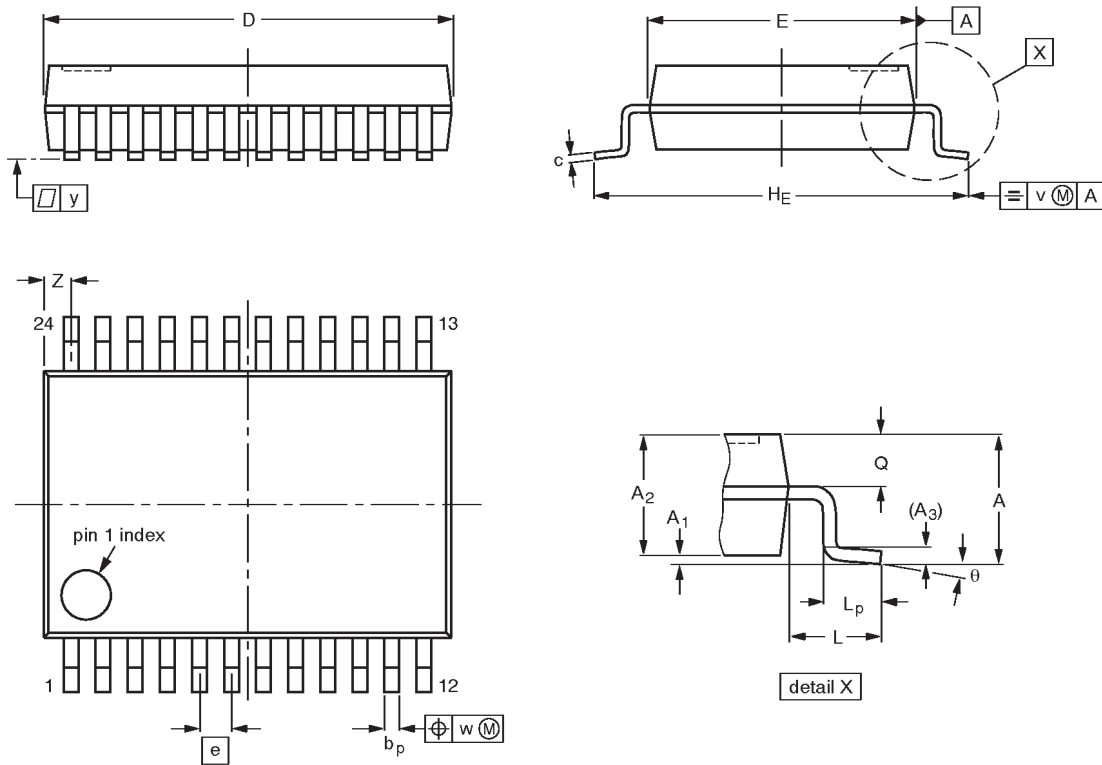

DIMENSIONS (mm are the original dimensions)

UNIT	A max.	A <sub>1</sub>	A <sub>2</sub>	A <sub>3</sub>	b <sub>p</sub>	c	D <sup>(1)</sup>	E <sup>(1)</sup>	e	H <sub>E</sub>	L	L <sub>p</sub>	Q	v	w	y	Z <sup>(1)</sup>	θ
mm	2.0	0.21 0.05	1.80 1.65	0.25	0.38 0.25	0.20 0.09	8.4 8.0	5.4 5.2	0.65	7.9 7.6	1.25	1.03 0.63	0.9 0.7	0.2	0.13	0.1	0.8 0.4	8° 0°

Note

1. Plastic or metal protrusions of 0.20 mm maximum per side are not included.

OUTLINE VERSION	REFERENCES				EUROPEAN PROJECTION	ISSUE DATE
	IEC	JEDEC	EIAJ			
SOT340-1		MO-150AG				93-09-08- 95-02-04

10-bit buffer/line driver, non-inverting (3-State)

74ABT827

TSSOP24: plastic thin shrink small outline package; 24 leads; body width 4.4 mm

SOT355-1

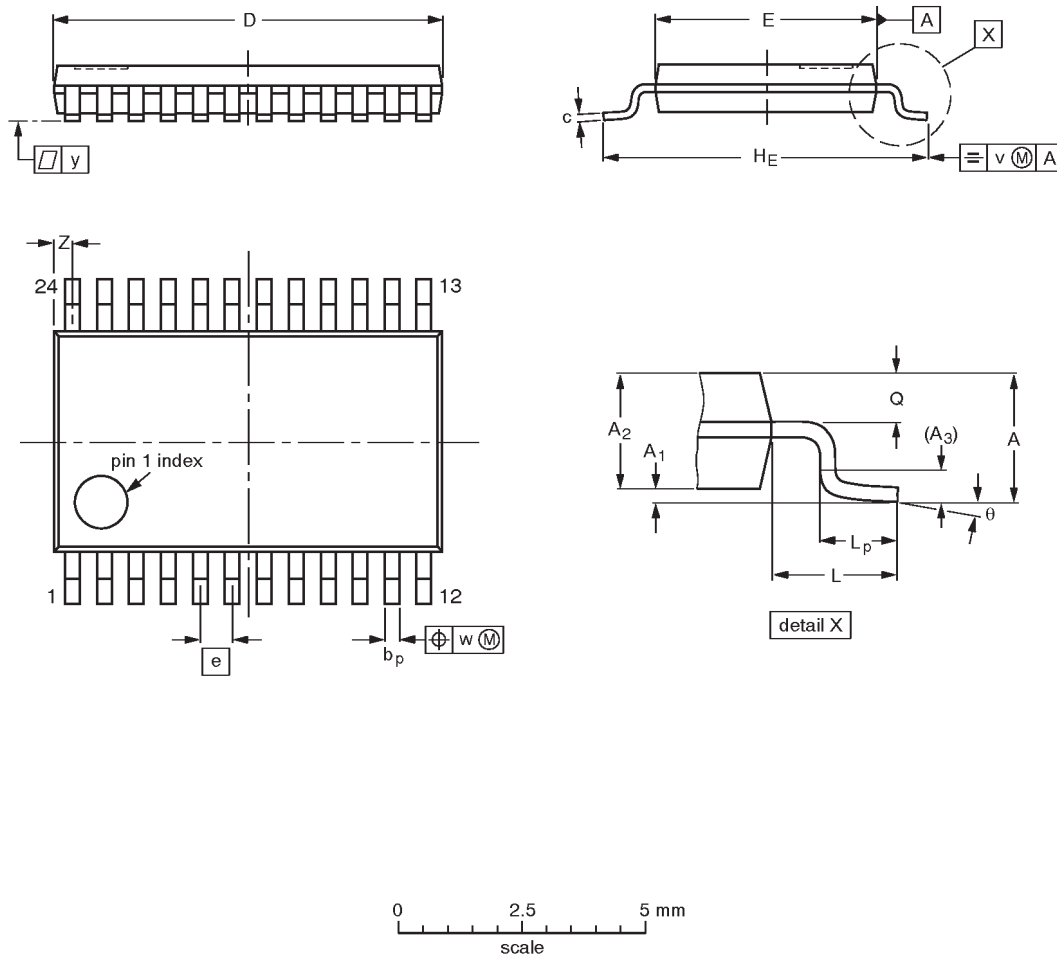

**DIMENSIONS (mm are the original dimensions)**

UNIT	A max.	A <sub>1</sub>	A <sub>2</sub>	A <sub>3</sub>	b <sub>p</sub>	c	D <sup>(1)</sup>	E <sup>(2)</sup>	e	H <sub>E</sub>	L	L <sub>p</sub>	Q	v	w	y	Z <sup>(1)</sup>	θ
mm	1.10	0.15 0.05	0.95 0.80	0.25	0.30 0.19	0.2 0.1	7.9 7.7	4.5 4.3	0.65	6.6 6.2	1.0	0.75 0.50	0.4 0.3	0.2	0.13	0.1	0.5 0.2	8° 0°

**Notes**

1. Plastic or metal protrusions of 0.15 mm maximum per side are not included.
2. Plastic interlead protrusions of 0.25 mm maximum per side are not included.

OUTLINE VERSION	REFERENCES				EUROPEAN PROJECTION	ISSUE DATE
	IEC	JEDEC	EIAJ			
SOT355-1		MO-153AD				-93-06-16 95-02-04

# 10-bit buffer/line driver, non-inverting (3-State)

74ABT827

## DEFINITIONS

Data Sheet Identification	Product Status	Definition
<i>Objective Specification</i>	<b>Formative or in Design</b>	This data sheet contains the design target or goal specifications for product development. Specifications may change in any manner without notice.
<i>Preliminary Specification</i>	<b>Preproduction Product</b>	This data sheet contains preliminary data, and supplementary data will be published at a later date. Philips Semiconductors reserves the right to make changes at any time without notice in order to improve design and supply the best possible product.
<i>Product Specification</i>	<b>Full Production</b>	This data sheet contains Final Specifications. Philips Semiconductors reserves the right to make changes at any time without notice, in order to improve design and supply the best possible product.

Philips Semiconductors and Philips Electronics North America Corporation reserve the right to make changes, without notice, in the products, including circuits, standard cells, and/or software, described or contained herein in order to improve design and/or performance. Philips Semiconductors assumes no responsibility or liability for the use of any of these products, conveys no license or title under any patent, copyright, or mask work right to these products, and makes no representations or warranties that these products are free from patent, copyright, or mask work right infringement, unless otherwise specified. Applications that are described herein for any of these products are for illustrative purposes only. Philips Semiconductors makes no representation or warranty that such applications will be suitable for the specified use without further testing or modification.

### LIFE SUPPORT APPLICATIONS

Philips Semiconductors and Philips Electronics North America Corporation Products are not designed for use in life support appliances, devices, or systems where malfunction of a Philips Semiconductors and Philips Electronics North America Corporation Product can reasonably be expected to result in a personal injury. Philips Semiconductors and Philips Electronics North America Corporation customers using or selling Philips Semiconductors and Philips Electronics North America Corporation Products for use in such applications do so at their own risk and agree to fully indemnify Philips Semiconductors and Philips Electronics North America Corporation for any damages resulting from such improper use or sale.

**Philips Semiconductors**  
**811 East Arques Avenue**  
**P.O. Box 3409**  
**Sunnyvale, California 94088-3409**  
**Telephone 800-234-7381**

Philips Semiconductors and Philips Electronics North America Corporation register eligible circuits under the Semiconductor Chip Protection Act.  
 © Copyright Philips Electronics North America Corporation 1998  
 All rights reserved. Printed in U.S.A.

(print code)

Date of release: July 1994

Document order number:

9397-750-03474