

74AC11353 DUAL 1-OR-4 DATA SELECTOR/MULTIPLEXER

SCAS044A – JUNE 1988 – REVISED APRIL 1993

- Inverting Version of 74AC11253
- Permits Multiplexing from N Lines to 1 Line
- Performs Parallel-to-Serial Conversion
- Flow-Through Architecture Optimizes PCB Layout
- Center-Pin V_{CC} and GND Configurations Minimize High-Speed Switching Noise
- EPIC™ (Enhanced-Performance Implanted CMOS) 1- μ m Process
- Package Options Include Plastic Small-Outline Packages, and Standard Plastic 300-mil DIPs

D OR N PACKAGE
(TOP VIEW)

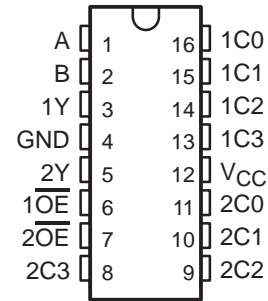

description

Each of these data selectors/multiplexers contains inverters and drivers to supply full binary decoding data selection to the AND-OR gates. Separate strobe output-enable ($\overline{1OE}$ or $\overline{2OE}$) inputs are provided for each of the two four-line sections.

The 3-state outputs can interface with and drive data lines of bus-organized systems. With all but one of the common outputs disabled (at a high-impedance state), the low impedance of the single enabled output will drive the bus line to a high or low logic level. Each output has its own strobe. The output is disabled when its strobe is high.

The 74AC11353 is characterized for operation from -40°C to 85°C .

FUNCTION TABLE

SELECT INPUTS		DATA INPUTS				STROBE \overline{OE}	OUTPUT Y
B	A	C0	C1	C2	C3		
X	X	X	X	X	X	H	Z
L	L	L	X	X	X	L	H
L	L	H	X	X	X	L	L
L	H	X	L	X	X	L	H
L	H	X	H	X	X	L	L
H	L	X	X	L	X	L	H
H	L	X	X	H	X	L	L
H	H	X	X	X	L	L	H
H	H	X	X	X	H	L	L

EPIC is a trademark of Texas Instruments Incorporated.

PRODUCTION DATA information is current as of publication date. Products conform to specifications per the terms of Texas Instruments standard warranty. Production processing does not necessarily include testing of all parameters.



POST OFFICE BOX 655303 • DALLAS, TEXAS 75265

Copyright © 1993, Texas Instruments Incorporated
Revision Information

74AC11353 DUAL 1-OR-4 DATA SELECTOR/MULTIPLEXER

SCAS044A – JUNE 1988 – REVISED APRIL 1993

logic symbol†

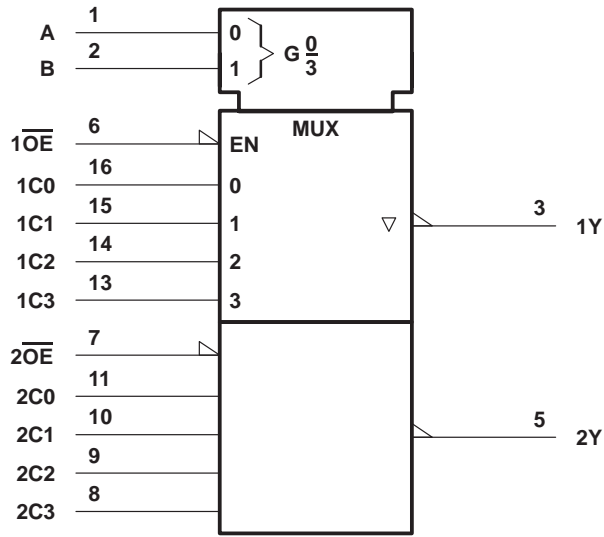

† This symbol is in accordance with ANSI/IEEE Std 91-1984 and IEC Publication 617-12.

logic diagram (positive logic)

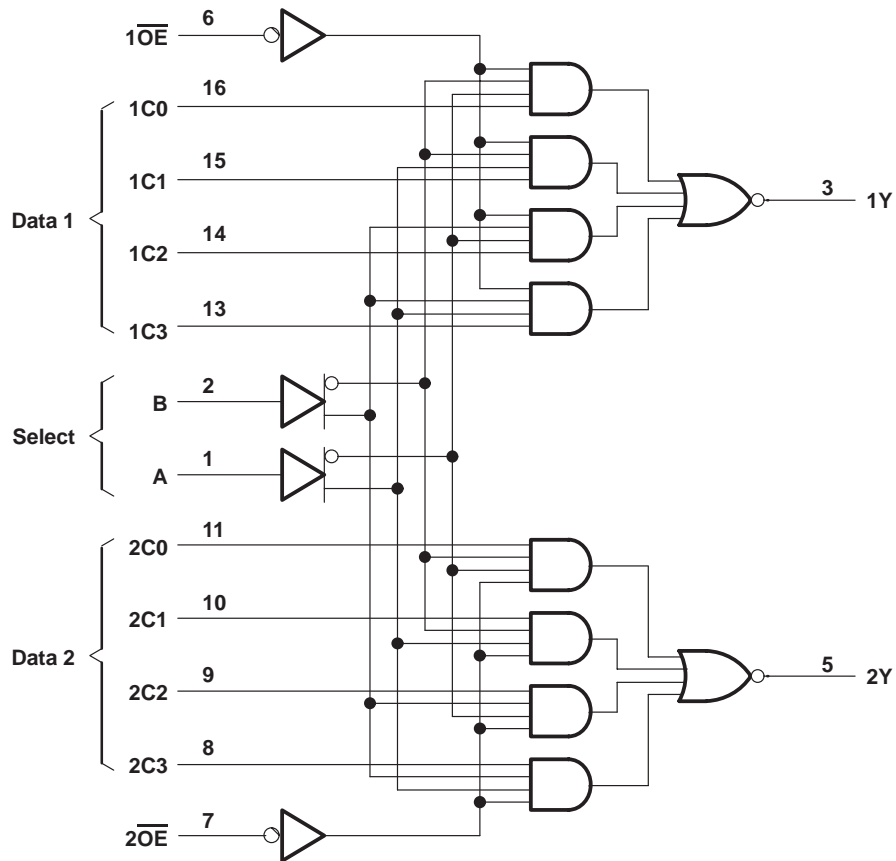

74AC11353 DUAL 1-OR-4 DATA SELECTOR/MULTIPLEXER

SCAS044A – JUNE 1988 – REVISED APRIL 1993

absolute maximum ratings over operating free-air temperature range (unless otherwise noted)†

Supply voltage range, V_{CC}	–0.5 V to 7 V
Input voltage range, V_I (see Note 1)	–0.5 V to $V_{CC} + 0.5$ V
Output voltage range, V_O (see Note 1)	–0.5 V to $V_{CC} + 0.5$ V
Input clamp current, I_{IK} ($V_I < 0$ or $V_I > V_{CC}$)	±20 mA
Output clamp current, I_{OK} ($V_O < 0$ or $V_O > V_{CC}$)	±50 mA
Continuous output current, I_O ($V_O = 0$ to V_{CC})	±50 mA
Continuous current through V_{CC} or GND pins	±100 mA
Storage temperature range	–65°C to 150°C

† Stresses beyond those listed under “absolute maximum ratings” may cause permanent damage to the device. These are stress ratings only and functional operation of the device at these or any other conditions beyond those indicated under “recommended operating conditions” is not implied. Exposure to absolute-maximum-rated conditions for extended periods may affect device reliability.

NOTE 1: The input and output voltage ratings may be exceeded if the input and output clamp-current ratings are observed.

recommended operating conditions

		MIN	NOM	MAX	UNIT
V_{CC}	Supply voltage	3	5	5.5	V
V_{IH}	High-level input voltage	$V_{CC} = 3$ V	2.1		V
		$V_{CC} = 4.5$ V	3.15		
		$V_{CC} = 5.5$ V	3.85		
V_{IL}	Low-level input voltage	$V_{CC} = 3$ V		0.9	V
		$V_{CC} = 4.5$ V		1.35	
		$V_{CC} = 5.5$ V		1.65	
V_I	Input voltage	0		V_{CC}	V
V_O	Output voltage	0		V_{CC}	V
I_{OH}	High-level output current	$V_{CC} = 3$ V		–4	mA
		$V_{CC} = 4.5$ V		–24	
		$V_{CC} = 5.5$ V		–24	
I_{OL}	Low-level output current	$V_{CC} = 3$ V		12	mA
		$V_{CC} = 4.5$ V		24	
		$V_{CC} = 5.5$ V		24	
$\Delta t/\Delta v$	Input transition rise or fall rate	0		10	ns/V
T_A	Operating free-air temperature	–40		85	°C



74AC11353

DUAL 1-OR-4 DATA SELECTOR/MULTIPLEXER

SCAS044A – JUNE 1988 – REVISED APRIL 1993

electrical characteristics over recommended operating free-air temperature range (unless otherwise noted)

PARAMETER	TEST CONDITIONS	V _{CC}	T _A = 25°C			MIN	MAX	UNIT
			MIN	TYP	MAX			
V _{OH}	I _{OH} = -50 μA	3 V	2.9			2.9		V
		4.5 V	4.4			4.4		
		5.5 V	5.4			5.4		
	I _{OH} = -4 mA	3 V	2.58			2.48		
		4.5 V	3.94			3.8		
		5.5 V	4.94			4.8		
I _{OH} = -75 mA [†]	5.5 V				3.85			
V _{OL}	I _{OL} = 50 μA	3 V				0.1		V
		4.5 V				0.1		
		5.5 V				0.1		
	I _{OL} = 12 mA	3 V				0.36		
		4.5 V				0.36		
		5.5 V				0.36		
I _{OL} = 75 mA [†]	5.5 V				1.65			
I _I	V _I = V _{CC} or GND	5.5 V				±0.1		μA
I _{OZ}	V _O = V _{CC} or GND	5.5 V				±0.5		±5 μA
I _{CC}	V _I = V _{CC} or GND, I _O = 0	5.5 V				8		80 μA
C _i	V _I = V _{CC} or GND	5 V	3.5					pF
C _O	V _O = V _{CC} or GND	5 V	8					pF

[†] Not more than one output should be tested at a time, and the duration of the test should not exceed 10 ms.

switching characteristics over recommended operating free-air temperature range, V_{CC} = 3.3 V ± 0.3 V (unless otherwise noted) (see Figure 1)

PARAMETER	FROM (INPUT)	TO (OUTPUT)	T _A = 25°C			MIN	MAX	UNIT
			MIN	TYP	MAX			
t _{PLH}	A or B	Y	1.5	7	9.6	1.5	10.7	ns
t _{PHL}			1.5	7.2	9.8	1.5	10.9	
t _{PLH}	Any C	Y	1.5	6.5	8.6	1.5	9.6	ns
t _{PHL}			1.5	6.6	8.7	1.5	9.7	
t _{PZH}	OE	Y	1.5	4.4	6	1.5	6.6	ns
t _{PZL}			1.5	5.4	7.2	1.5	7.9	
t _{PHZ}	OE	Y	1.5	4.8	6.2	1.5	6.5	ns
t _{PLZ}			1.5	4.9	6.3	1.5	6.6	

switching characteristics over recommended operating free-air temperature range,
 $V_{CC} = 5\text{ V} \pm 0.5\text{ V}$ (unless otherwise noted) (see Figure 1)

PARAMETER	FROM (INPUT)	TO (OUTPUT)	$T_A = 25^\circ\text{C}$			MIN	MAX	UNIT
			MIN	TYP	MAX			
t_{PLH}	A or B	Y	1.5	4.5	6.6	1.5	7.4	ns
t_{PHL}			1.5	4.6	6.9	1.5	7.6	
t_{PLH}	Any C	Y	1.5	4	5.9	1.5	6.6	ns
t_{PHL}			1.5	4.2	6.1	1.5	6.8	
t_{PZH}	OE	Y	1.5	2.9	4.4	1.5	4.8	ns
t_{PZL}			1.5	3.4	5.1	1.5	5.6	
t_{PHZ}	OE	Y	1.5	4.4	5.8	1.5	6.1	ns
t_{PLZ}			1.5	4.1	5.5	1.5	5.8	

operating characteristics, $V_{CC} = 5\text{ V}$, $T_A = 25^\circ\text{C}$

PARAMETER		TEST CONDITIONS	TYP	UNIT
C_{pd}	Power dissipation capacitance per multiplexer	Outputs enabled	31	pF
		Outputs disabled	12	

PARAMETER MEASUREMENT INFORMATION

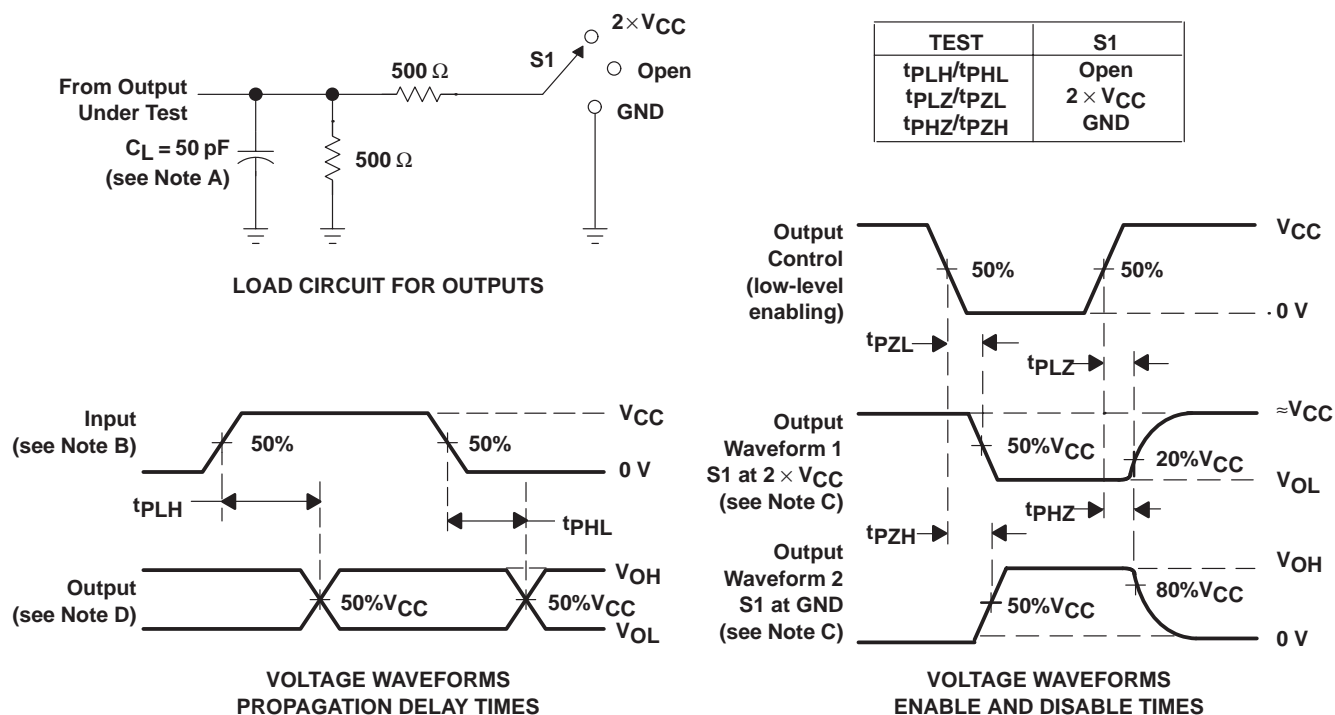

- NOTES: A. C_L includes probe and jig capacitance.
 B. All input pulses are supplied by generators having the following characteristics: $PRR \leq 10\text{ MHz}$, $Z_0 = 50\ \Omega$, $t_r \leq 3\text{ ns}$, $t_f \leq 3\text{ ns}$. For testing pulse duration: $t_r = t_f = 1\text{ to }3\text{ ns}$. Pulse polarity can be either high-to-low-to-high or low-to-high-to-low.
 C. Waveform 1 is for an output with internal conditions such that the output is low except when disabled by the output control. Waveform 2 is for an output with internal conditions such that the output is high except when disabled by the output control.
 D. The outputs are measured one at a time with one transition per measurement.

Figure 1. Load Circuit and Voltage Waveforms

IMPORTANT NOTICE

Texas Instruments and its subsidiaries (TI) reserve the right to make changes to their products or to discontinue any product or service without notice, and advise customers to obtain the latest version of relevant information to verify, before placing orders, that information being relied on is current and complete. All products are sold subject to the terms and conditions of sale supplied at the time of order acknowledgement, including those pertaining to warranty, patent infringement, and limitation of liability.

TI warrants performance of its semiconductor products to the specifications applicable at the time of sale in accordance with TI's standard warranty. Testing and other quality control techniques are utilized to the extent TI deems necessary to support this warranty. Specific testing of all parameters of each device is not necessarily performed, except those mandated by government requirements.

CERTAIN APPLICATIONS USING SEMICONDUCTOR PRODUCTS MAY INVOLVE POTENTIAL RISKS OF DEATH, PERSONAL INJURY, OR SEVERE PROPERTY OR ENVIRONMENTAL DAMAGE ("CRITICAL APPLICATIONS"). TI SEMICONDUCTOR PRODUCTS ARE NOT DESIGNED, AUTHORIZED, OR WARRANTED TO BE SUITABLE FOR USE IN LIFE-SUPPORT DEVICES OR SYSTEMS OR OTHER CRITICAL APPLICATIONS. INCLUSION OF TI PRODUCTS IN SUCH APPLICATIONS IS UNDERSTOOD TO BE FULLY AT THE CUSTOMER'S RISK.

In order to minimize risks associated with the customer's applications, adequate design and operating safeguards must be provided by the customer to minimize inherent or procedural hazards.

TI assumes no liability for applications assistance or customer product design. TI does not warrant or represent that any license, either express or implied, is granted under any patent right, copyright, mask work right, or other intellectual property right of TI covering or relating to any combination, machine, or process in which such semiconductor products or services might be or are used. TI's publication of information regarding any third party's products or services does not constitute TI's approval, warranty or endorsement thereof.