

9 BIT PARITY GENERATOR

- HIGH SPEED: $t_{PD} = 4 \text{ ns}$ (TYP.) at $V_{CC} = 5V$
- LOW POWER DISSIPATION:
 $I_{CC} = 4 \mu A$ (MAX.) at $T_A = 25 \text{ }^\circ C$
- HIGH NOISE IMMUNITY:
 $V_{NIH} = V_{NIL} = 28\% V_{CC}$ (MIN.)
- 50Ω TRANSMISSION LINE DRIVING CAPABILITY
- SYMMETRICAL OUTPUT IMPEDANCE:
 $|I_{OH}| = I_{OL} = 24 \text{ mA}$ (MIN)
- BALANCED PROPAGATION DELAYS:
 $t_{PLH} \cong t_{PHL}$
- OPERATING VOLTAGE RANGE:
 V_{CC} (OPR) = 2V to 6V
- PIN AND FUNCTION COMPATIBLE WITH 74 SERIES 280
- IMPROVED LATCH-UP IMMUNITY

DESCRIPTION

The AC280 is an advanced high-speed CMOS 9 BIT PARITY GENERATOR fabricated with sub-micron silicon gate and double-layer metal wiring C²MOS technology. It is ideal for low power applications maintaining high speed operation similar to equivalent Bipolar Schottky TTL.

It is composed of nine data inputs (A to I) and

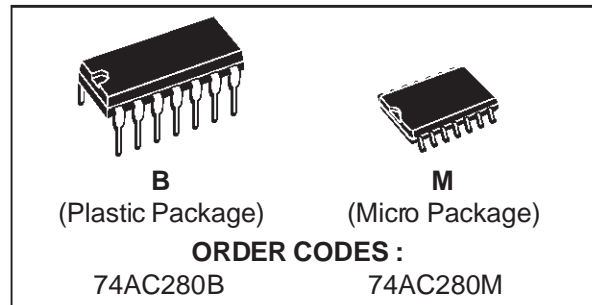

odd/even parity outputs (ΣODD and $\Sigma EVEN$). The nine data inputs control the output conditions. When the number of high level input is odd, ΣODD output is kept high and $\Sigma EVEN$ output low. Conservely, when the output is even, $\Sigma EVEN$ output is kept high and ΣODD low.

The IC generates either odd or even parity making it flexible application.

The word-length capability is easily expanded by cascading.

All inputs and outputs are equipped with protection circuits against static discharge, giving them 2KV ESD immunity and transient excess voltage.

PIN CONNECTION AND IEC LOGIC SYMBOLS

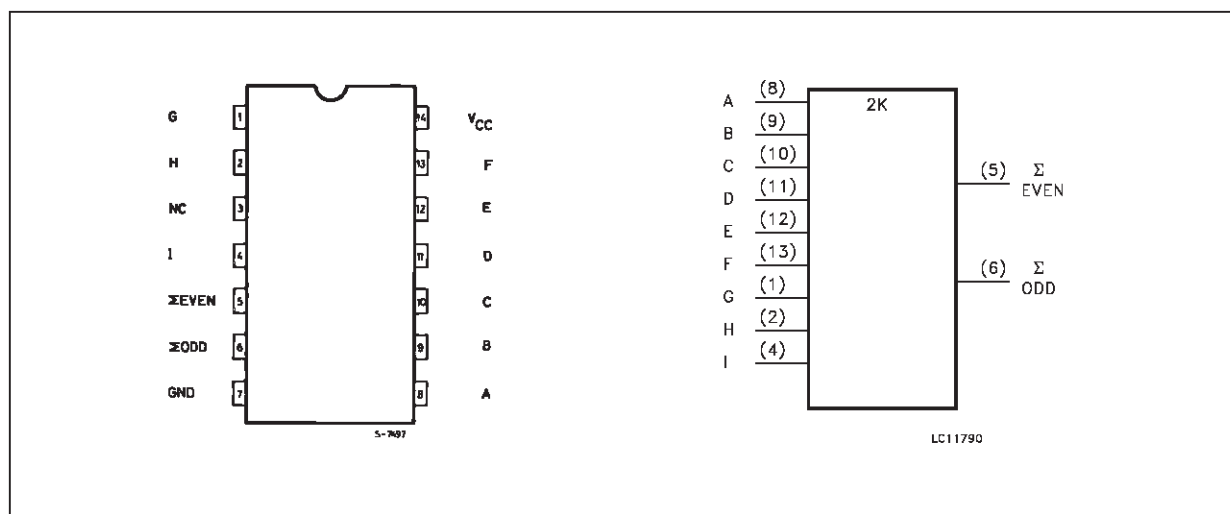

INPUT AND OUTPUT EQUIVALENT CIRCUIT

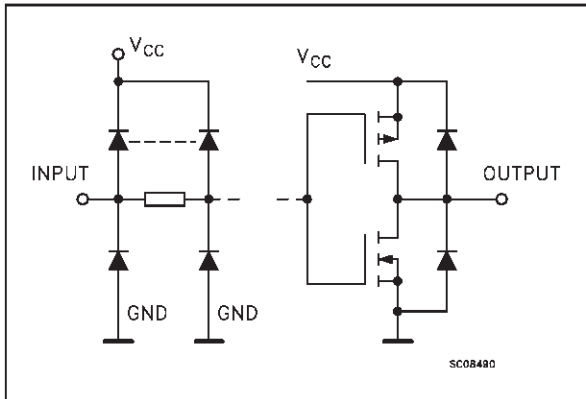

PIN DESCRIPTION

PIN No	SYMBOL	NAME AND FUNCTION
5, 6	Σ EVEN Σ ODD	Parity Outputs
8, 9, 10, 11, 12, 13, 1, 2, 4	A to I	Data Inputs
3	NC	No Connection
7	GND	Ground (0V)
14	V _{CC}	Positive Supply Voltage

TRUTH TABLE

NUMBER OF INPUTS A THRU I THAT ARE HIGH	OUTPUT	
	Σ EVEN	Σ ODD
0, 2, 4, 6, 8	H	L
1, 3, 5, 7, 9	L	H

LOGIC DIAGRAM

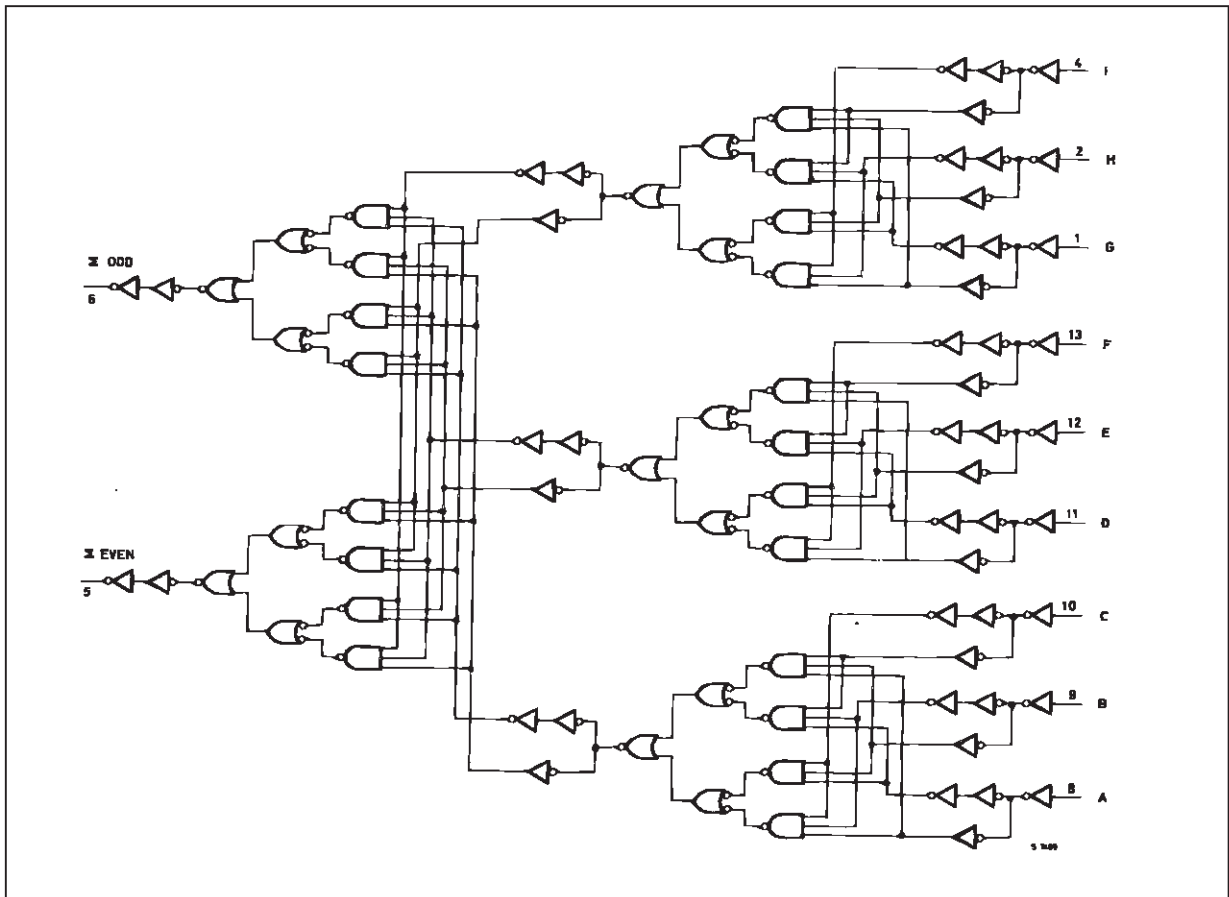

ABSOLUTE MAXIMUM RATINGS

Symbol	Parameter	Value	Unit
V_{CC}	Supply Voltage	-0.5 to +7	V
V_I	DC Input Voltage	-0.5 to $V_{CC} + 0.5$	V
V_O	DC Output Voltage	-0.5 to $V_{CC} + 0.5$	V
I_{IK}	DC Input Diode Current	± 20	mA
I_{OK}	DC Output Diode Current	± 20	mA
I_O	DC Output Current	± 50	mA
I_{CC} or I_{GND}	DC V_{CC} or Ground Current	± 200	mA
T_{stg}	Storage Temperature	-65 to +150	$^{\circ}C$
T_L	Lead Temperature (10 sec)	300	$^{\circ}C$

Absolute Maximum Ratings are those values beyond which damage to the device may occur. Functional operation under these condition is not implied.

RECOMMENDED OPERATING CONDITIONS

Symbol	Parameter	Value	Unit
V_{CC}	Supply Voltage	2 to 6	V
V_I	Input Voltage	0 to V_{CC}	V
V_O	Output Voltage	0 to V_{CC}	V
T_{op}	Operating Temperature:	-40 to +85	$^{\circ}C$
dt/dv	Input Rise and Fall Time $V_{CC} = 3.0, 4.5$ or 5.5 V(note 1)	8	ns/V

1) V_{IN} from 30% to 70% of V_{CC}

DC SPECIFICATIONS

Symbol	Parameter	Test Conditions		Value					Unit	
		V _{CC} (V)		T _A = 25 °C			-40 to 85 °C			
				Min.	Typ.	Max.	Min.	Max.		
V _{IH}	High Level Input Voltage	3.0	V _O = 0.1 V or V _{CC} - 0.1 V	2.1	1.5		2.1		V	
		4.5		3.15	2.25		3.15			
		5.5		3.85	2.75		3.85			
V _{IL}	Low Level Input Voltage	3.0	V _O = 0.1 V or V _{CC} - 0.1 V		1.5	0.9		0.9	V	
		4.5			2.25	1.35		1.35		
		5.5			2.75	1.65		1.65		
V _{OH}	High Level Output Voltage	3.0	V _I ^(*) = V _{IH} or V _{IL}	I _O = -50 μA	2.9	2.99		2.9	V	
		4.5		I _O = -50 μA	4.4	4.49		4.4		
		5.5		I _O = -50 μA	5.4	5.49		5.4		
		3.0		I _O = -12 mA	2.56			2.46		
		4.5		I _O = -24 mA	3.86			3.76		
		5.5		I _O = -24 mA	4.86			4.76		
V _{OL}	Low Level Output Voltage	3.0	V _I ^(*) = V _{IH} or V _{IL}	I _O = 50 μA		0.002	0.1		0.1	V
		4.5		I _O = 50 μA		0.001	0.1		0.1	
		5.5		I _O = 50 μA		0.001	0.1		0.1	
		3.0		I _O = 12 mA			0.36		0.44	
		4.5		I _O = 24 mA			0.36		0.44	
		5.5		I _O = 24 mA			0.36		0.44	
I _I	Input Leakage Current	5.5	V _I = V _{CC} or GND			±0.1		±1	μA	
I _{CC}	Quiescent Supply Current	5.5	V _I = V _{CC} or GND			4		40	μA	
I _{OLD}	Dynamic Output Current (note 1, 2)	5.5	V _{OLD} = 1.65 V max					75	mA	
I _{OHD}			V _{OHD} = 3.85 V min					-75	mA	

1) Maximum test duration 2ms, one output loaded at time

2) Incident wave switching is guaranteed on transmission lines with impedances as low as 50 Ω.

(*) All outputs loaded.

AC ELECTRICAL CHARACTERISTICS (C_L = 50 pF, R_L = 500 Ω, Input t_r = t_f = 3 ns)

Symbol	Parameter	Test Condition		Value					Unit
		V _{CC} (V)		T _A = 25 °C			-40 to 85 °C		
				Min.	Typ.	Max.	Min.	Max.	
t _{PLH} t _{PHL}	Propagation Delay Time (Input - ΣODD, ΣEVEN)	3.3 ^(*)		1.5	5	17.0	1	18.5	ns
		5.0 ^(**)		1.5	4	13.0	1	14.5	

(*) Voltage range is 3.3V ± 0.3V

(**) Voltage range is 5V ± 0.5V

CAPACITIVE CHARACTERISTICS

Symbol	Parameter	Test Conditions		Value					Unit
		V _{CC} (V)		T _A = 25 °C			-40 to 85 °C		
				Min.	Typ.	Max.	Min.	Max.	
C _{IN}	Input Capacitance	5.0			4				pF
C _{PD}	Power Dissipation Capacitance (note 1)	5.0			27				pF

1) C_{PD} is defined as the value of the IC's internal equivalent capacitance which is calculated from the operating current consumption without load. (Refer to Test Circuit). Average operating current can be obtained by the following equation. I_{CC(OPR)} = C_{PD} • V_{CC} • f_{IN} + I_{CC}

TEST CIRCUIT

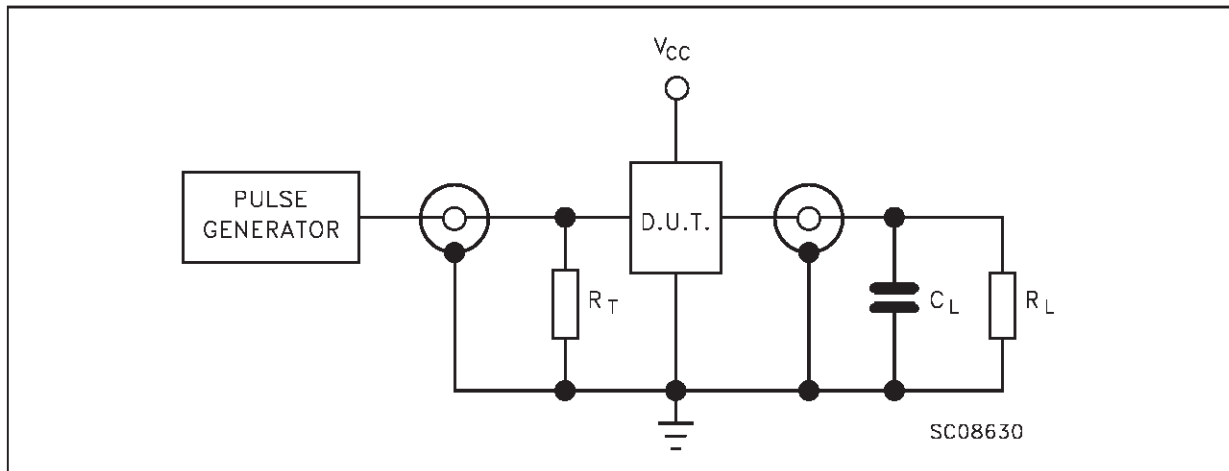

$C_L = 50$ pF or equivalent (includes jig and probe capacitance)

$R_L = R_T = 500\Omega$ or equivalent

$R_T = Z_{out}$ of pulse generator (typically 50Ω)

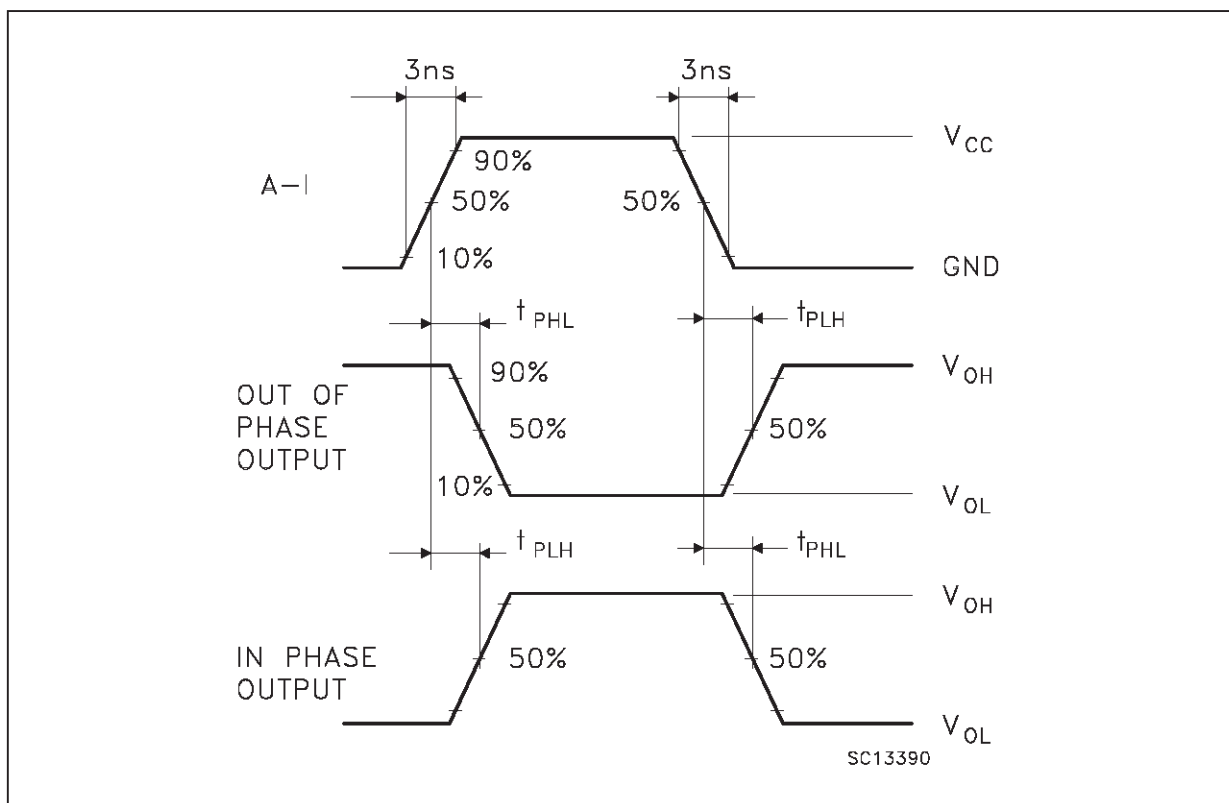
WAVEFORM: PROPAGATION DELAYS ($f=1$ MHz; 50% duty cycle)

Plastic DIP-14 MECHANICAL DATA

DIM.	mm			inch		
	MIN.	TYP.	MAX.	MIN.	TYP.	MAX.
a1	0.51			0.020		
B	1.39		1.65	0.055		0.065
b		0.5			0.020	
b1		0.25			0.010	
D			20			0.787
E		8.5			0.335	
e		2.54			0.100	
e3		15.24			0.600	
F			7.1			0.280
I			5.1			0.201
L		3.3			0.130	
Z	1.27		2.54	0.050		0.100

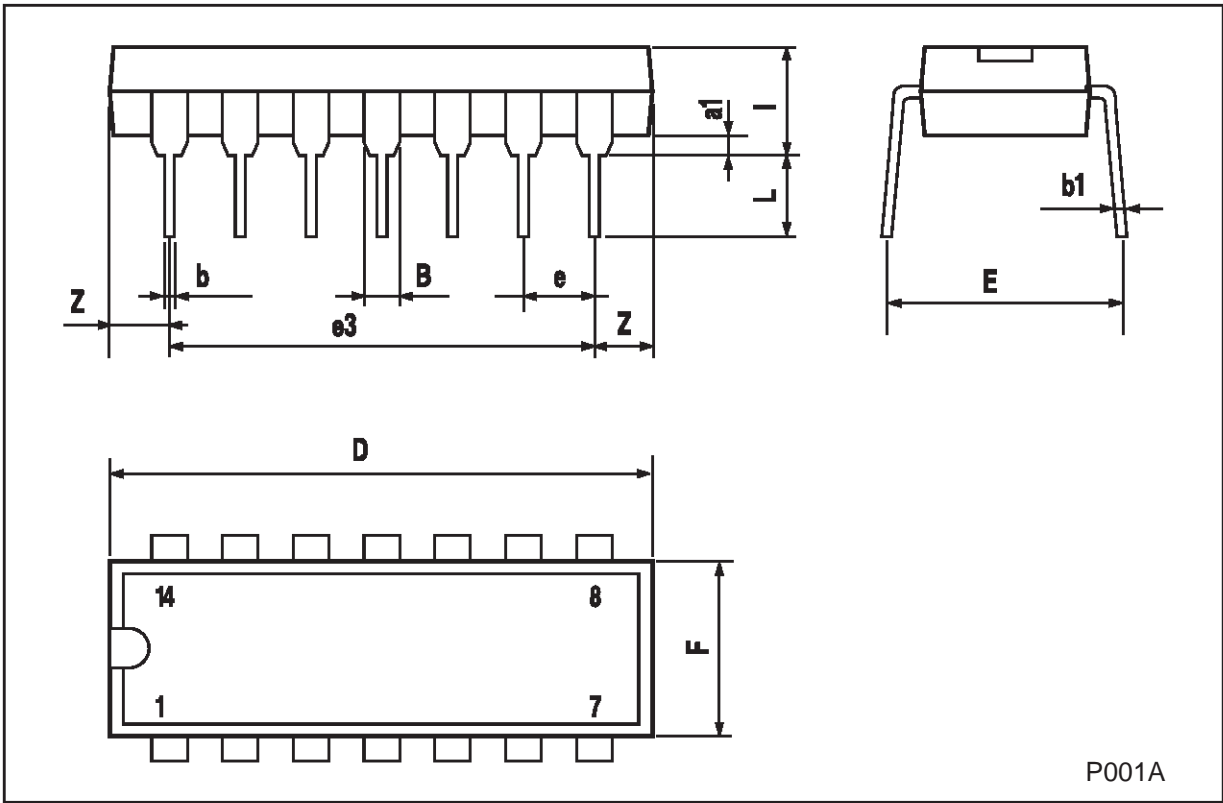

P001A

SO-14 MECHANICAL DATA

DIM.	mm			inch		
	MIN.	TYP.	MAX.	MIN.	TYP.	MAX.
A			1.75			0.068
a1	0.1		0.2	0.003		0.007
a2			1.65			0.064
b	0.35		0.46	0.013		0.018
b1	0.19		0.25	0.007		0.010
C		0.5			0.019	
c1	45 (typ.)					
D	8.55		8.75	0.336		0.344
E	5.8		6.2	0.228		0.244
e		1.27			0.050	
e3		7.62			0.300	
F	3.8		4.0	0.149		0.157
G	4.6		5.3	0.181		0.208
L	0.5		1.27	0.019		0.050
M			0.68			0.026
S	8 (max.)					

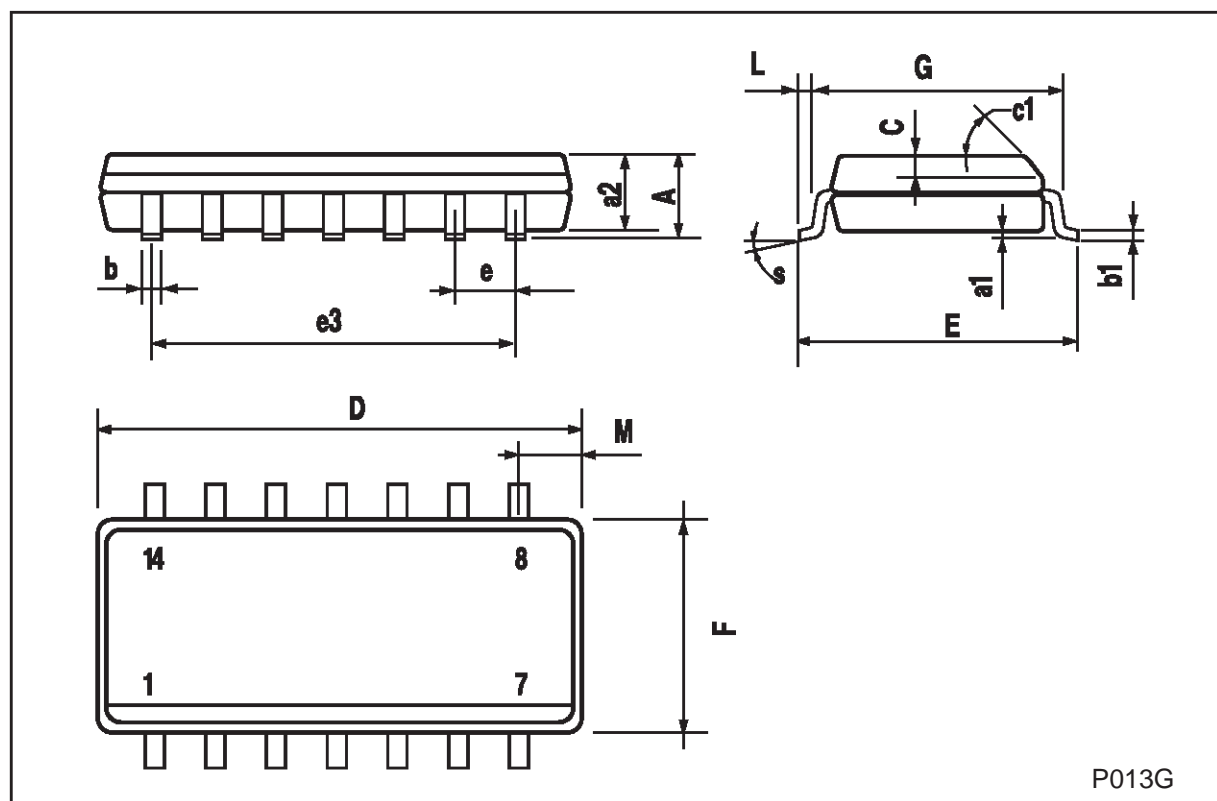

Information furnished is believed to be accurate and reliable. However, STMicroelectronics assumes no responsibility for the consequences of use of such information nor for any infringement of patents or other rights of third parties which may result from its use. No license is granted by implication or otherwise under any patent or patent rights of STMicroelectronics. Specification mentioned in this publication are subject to change without notice. This publication supersedes and replaces all information previously supplied. STMicroelectronics products are not authorized for use as critical components in life support devices or systems without express written approval of STMicroelectronics.

The ST logo is a registered trademark of STMicroelectronics

© 1998 STMicroelectronics – Printed in Italy – All Rights Reserved
STMicroelectronics GROUP OF COMPANIES

Australia - Brazil - Canada - China - France - Germany - Italy - Japan - Korea - Malaysia - Malta - Mexico - Morocco - The Netherlands -
Singapore - Spain - Sweden - Switzerland - Taiwan - Thailand - United Kingdom - U.S.A.

<http://www.st.com>