

FEATURES:

- 5Ω A/B bi-directional switch
- Isolation under power-off conditions
- Over-voltage tolerant
- Latch-up performance exceeds 100mA
- $V_{CC} = 2.3V - 3.6V$, Normal Range
- ESD > 2000V per MIL-STD-883, Method 3015;
> 200V using machine model (C = 200pF, R = 0)
- Available in QSOP and TSSOP packages

APPLICATIONS:

- 3.3V High Speed Bus Switching and Bus Isolation

DESCRIPTION:

The CBTLV3861 provides ten bits of high-speed bus switching with low on-state resistance of the switch allowing connections to be made with minimal propagation delay.

The device is organized as one 10-bit bus switch. When output enable (\overline{OE}) is low, the 10-bit bus switch is on and port A is connected to port B. When \overline{OE} is high, the switch is open and a high-impedance state exists between the two ports.

To ensure the high-impedance state during power up or power down, \overline{OE} should be tied to V_{CC} through a pullup resistor; the minimum value of the resistor is determined by the current-sinking capability of the driver.

FUNCTIONAL BLOCK DIAGRAM

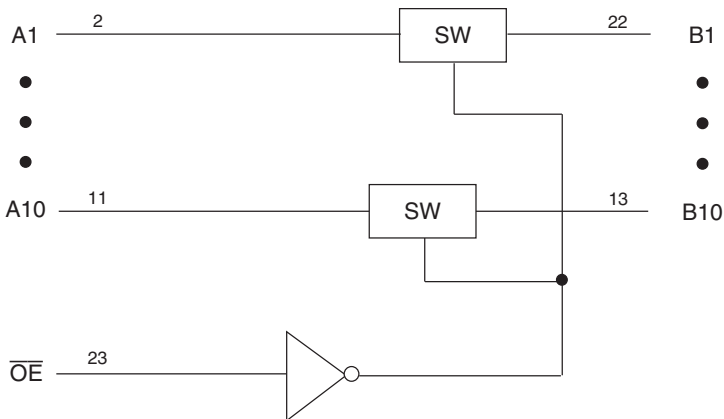

SIMPLIFIED SCHEMATIC, EACH SWITCH

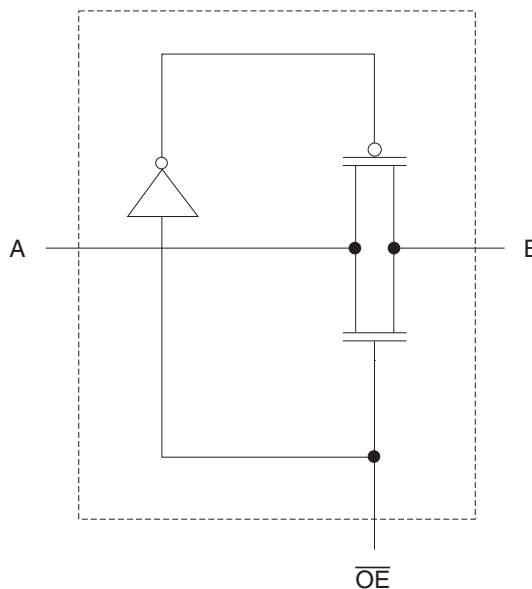

PIN CONFIGURATION

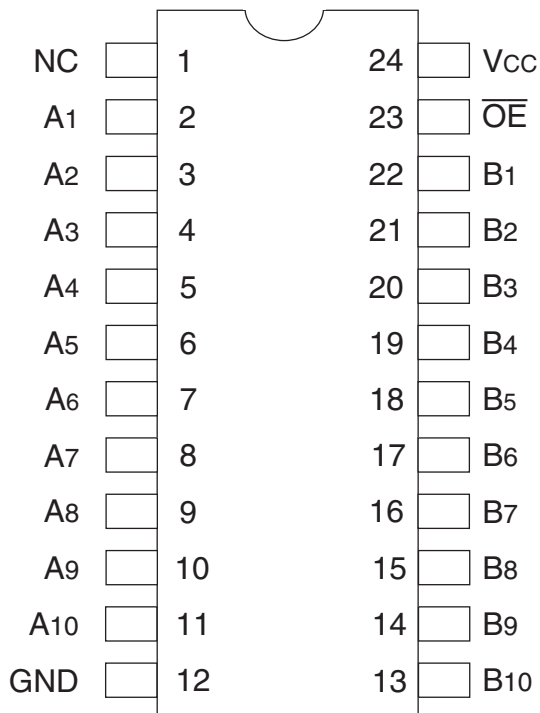

TOP VIEW

Package Type	Package Code	Order Code
TSSOP	PGG24	PGG
QSOP	PCG24	QG

ABSOLUTE MAXIMUM RATINGS⁽¹⁾

Symbol	Description	Max	Unit
V _{CC}	Supply Voltage Range	-0.5 to +4.6	V
V _I	Input Voltage Range	-0.5 to +4.6	V
	Continuous Channel Current	128	mA
I _{IK}	Input Clamp Current, V _{I/O} < 0	-50	mA
T _{STG}	Storage Temperature	-65 to +150	°C

NOTE:

1. Stresses greater than those listed under ABSOLUTE MAXIMUM RATINGS may cause permanent damage to the device. This is a stress rating only and functional operation of the device at these or any other conditions above those indicated in the operational sections of this specification is not implied. Exposure to absolute maximum rating conditions for extended periods may affect reliability.

FUNCTION TABLE⁽¹⁾

Input	Operation
\overline{OE}	
L	A Port = B Port
H	Disconnect

NOTE:

1. H = HIGH Voltage Level
L = LOW Voltage Level

OPERATING CHARACTERISTICS, T_A = 25°C⁽¹⁾

Symbol	Parameter	Test Conditions	Min.	Max.	Unit
V _{CC}	Supply Voltage		2.3	3.6	V
V _{IH}	High-Level Control Input Voltage	V _{CC} = 2.3V to 2.7V	1.7	—	V
		V _{CC} = 2.7V to 3.6V	2	—	
V _{IL}	Low-Level Control Input Voltage	V _{CC} = 2.3V to 2.7V	—	0.7	V
		V _{CC} = 2.7V to 3.6V	—	0.8	
T _A	Operating Free-Air Temperature		-40	85	°C

NOTE:

1. All unused control inputs of the device must be held at V_{CC} or GND to ensure proper device operation.

DC ELECTRICAL CHARACTERISTICS OVER OPERATING RANGE

Following Conditions Apply Unless Otherwise Specified:

Operating Conditions: $T_A = -40^{\circ}\text{C}$ to $+85^{\circ}\text{C}$

Symbol	Parameter	Test Conditions	Min.	Typ. ⁽¹⁾	Max.	Unit	
V_{IK}	Control Inputs, Data I/O	$V_{CC} = 3V$, $I_I = -18\text{mA}$	—	—	-1.2	V	
I_I	Control Inputs, Data I/O	$V_{CC} = 3.6V$, $V_I = V_{CC}$ or GND	—	—	± 1	μA	
I_{OZ}	Data I/O	$V_{CC} = 3.6V$, $V_O = 0$ or $3.6V$, switch disabled	—	—	5	μA	
I_{OFF}		$V_{CC} = 0$, V_I or $V_O = 0$ to $3.6V$	—	—	50	μA	
I_{CC}		$V_{CC} = 3.6V$, $I_O = 0$, $V_I = V_{CC}$ or GND	—	—	10	μA	
$\Delta I_{CC}^{(2)}$	Control Inputs	$V_{CC} = 3.6V$, one input at $3V$, other inputs at V_{CC} or GND	—	—	300	μA	
C_I	Control Inputs	$V_I = 3V$ or 0	—	4	—	pF	
$C_{IO(OFF)}$		$V_O = 3V$ or 0 , $\overline{OE} = V_{CC}$	—	6	—	pF	
$R_{ON}^{(3)}$	$V_{CC} = 2.3V$ Typ. at $V_{CC} = 2.5V$	$V_I = 0$	$I_O = 64\text{mA}$	—	5	8	Ω
			$I_O = 24\text{mA}$	—	5	8	
	$V_I = 1.7V$	$I_O = 15\text{mA}$	—	27	40		
	$V_{CC} = 3V$	$V_I = 0$	$I_O = 64\text{mA}$	—	5	7	
			$I_O = 24\text{mA}$	—	5	7	
		$V_I = 2.4V$	$I_O = 15\text{mA}$	—	10	15	

NOTES:

- Typical values are at $V_{CC} = 3.3V$, $+25^{\circ}\text{C}$ ambient.
- The increase in supply current is attributable to each current that is at the specified voltage level rather than V_{CC} or GND.
- This is measured by the voltage drop between the A and B terminals at the indicated current through the switch.

SWITCHING CHARACTERISTICS

Symbol	Parameter	$V_{CC} = 2.5V \pm 0.2V$		$V_{CC} = 3.3V \pm 0.3V$		Unit
		Min.	Max.	Min.	Max.	
$t_{PD}^{(1)}$	Propagation Delay A to B or B to A	—	0.15	—	0.25	ns
t_{EN}	Output Enable Time \overline{OE} to A or B	1	4.5	1	4.2	ns
t_{DIS}	Output Disable Time \overline{OE} to A or B	1	5	1	5	ns

- NOTE:**
- The propagation delay is the calculated RC time constant of the typical on-state resistance of the switch and the specified load capacitance driven by an ideal voltage source (zero output impedance).

TEST CIRCUITS AND WAVEFORMS

TEST CONDITIONS

Symbol	V _{CC} ⁽¹⁾ = 3.3V±0.3V	V _{CC} ⁽²⁾ = 2.5V±0.2V	Unit
V _{LOAD}	6	2 x V _{CC}	V
V _{IH}	3	V _{CC}	V
V _T	1.5	V _{CC} / 2	V
V _{LZ}	300	150	mV
V _{HZ}	300	150	mV
C _L	50	30	pF

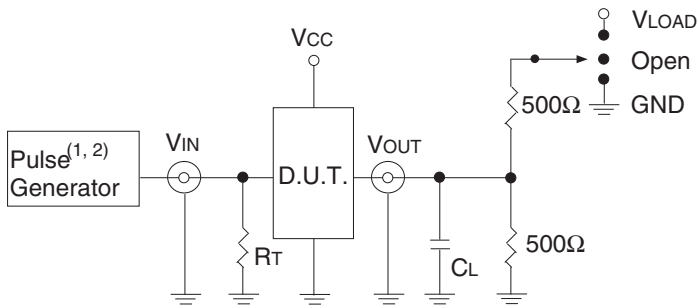

Test Circuits for All Outputs

DEFINITIONS:

C_L = Load capacitance: includes jig and probe capacitance.
R_T = Termination resistance: should be equal to Z_{OUT} of the Pulse Generator.

NOTES:

1. Pulse Generator for All Pulses: Rate ≤ 1.0MHz; t_r ≤ 2.5ns; t_r ≤ 2.5ns.
2. Pulse Generator for All Pulses: Rate ≤ 1.0MHz; t_r ≤ 2ns; t_r ≤ 2.5ns.

SWITCH POSITION

Test	Switch
t _{PLZ} /t _{PZL}	V _{LOAD}
t _{PHZ} /t _{PZH}	GND
t _{PD}	Open

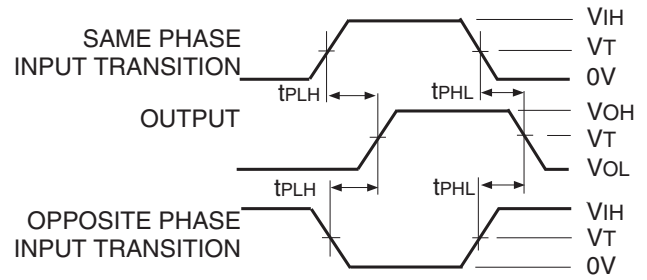

Propagation Delay

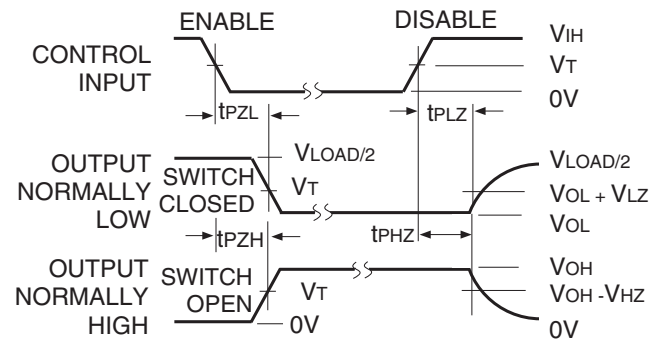

Enable and Disable Times

ORDERING INFORMATION

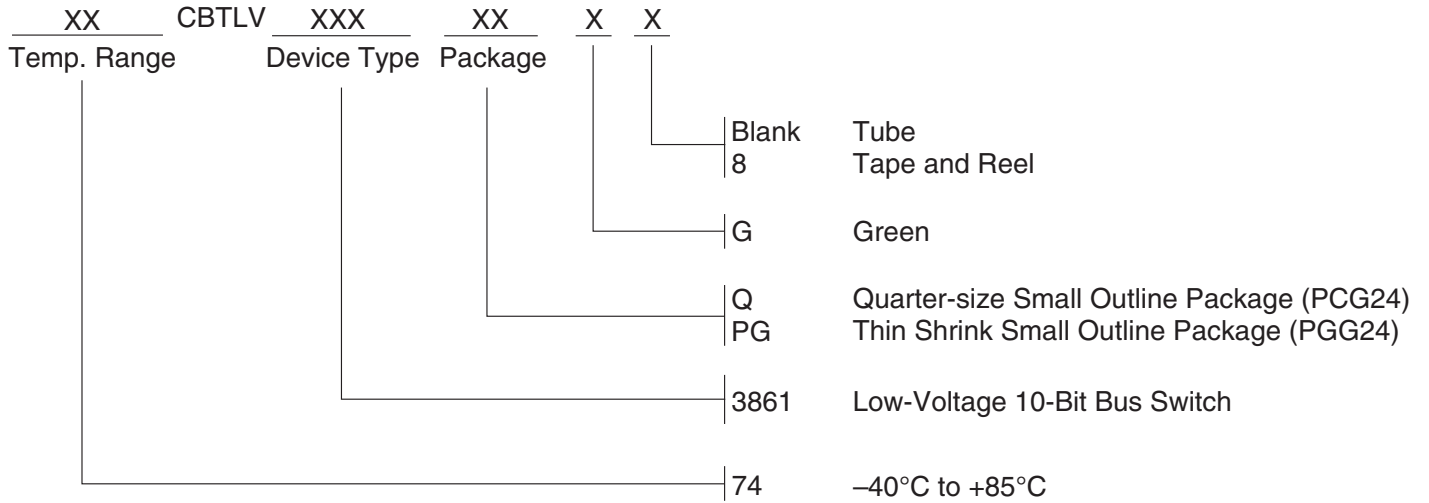

Orderable Part Information

Speed (ns)	Orderable Part ID	Pkg. Code	Pkg. Type	Temp. Grade
	74CBTLV3861PGG	PGG24	TSSOP	I
	74CBTLV3861PGG8	PGG24	TSSOP	I
	74CBTLV3861QG	PCG24	QSOP	I
	74CBTLV3861QG8	PCG24	QSOP	I

Datasheet Document History

10/02/2012	Pg. 5	Updated the ordering information by removing the "IDT" notation also by removing non RoHS part and by adding Tape and Reel information.
05/10/2019	Pg. 2,5	Added table under pin configuration diagram with detailed package information and orderable part information table. Updated the ordering information diagram in clearer detail.

Notice

1. Descriptions of circuits, software and other related information in this document are provided only to illustrate the operation of semiconductor products and application examples. You are fully responsible for the incorporation or any other use of the circuits, software, and information in the design of your product or system. Renesas Electronics disclaims any and all liability for any losses and damages incurred by you or third parties arising from the use of these circuits, software, or information.
2. Renesas Electronics hereby expressly disclaims any warranties against and liability for infringement or any other claims involving patents, copyrights, or other intellectual property rights of third parties, by or arising from the use of Renesas Electronics products or technical information described in this document, including but not limited to, the product data, drawings, charts, programs, algorithms, and application examples.
3. No license, express, implied or otherwise, is granted hereby under any patents, copyrights or other intellectual property rights of Renesas Electronics or others.
4. You shall not alter, modify, copy, or reverse engineer any Renesas Electronics product, whether in whole or in part. Renesas Electronics disclaims any and all liability for any losses or damages incurred by you or third parties arising from such alteration, modification, copying or reverse engineering.
5. Renesas Electronics products are classified according to the following two quality grades: "Standard" and "High Quality". The intended applications for each Renesas Electronics product depends on the product's quality grade, as indicated below.
 - "Standard": Computers; office equipment; communications equipment; test and measurement equipment; audio and visual equipment; home electronic appliances; machine tools; personal electronic equipment; industrial robots; etc.
 - "High Quality": Transportation equipment (automobiles, trains, ships, etc.); traffic control (traffic lights); large-scale communication equipment; key financial terminal systems; safety control equipment; etc.Unless expressly designated as a high reliability product or a product for harsh environments in a Renesas Electronics data sheet or other Renesas Electronics document, Renesas Electronics products are not intended or authorized for use in products or systems that may pose a direct threat to human life or bodily injury (artificial life support devices or systems; surgical implantations; etc.), or may cause serious property damage (space system; undersea repeaters; nuclear power control systems; aircraft control systems; key plant systems; military equipment; etc.). Renesas Electronics disclaims any and all liability for any damages or losses incurred by you or any third parties arising from the use of any Renesas Electronics product that is inconsistent with any Renesas Electronics data sheet, user's manual or other Renesas Electronics document.
6. When using Renesas Electronics products, refer to the latest product information (data sheets, user's manuals, application notes, "General Notes for Handling and Using Semiconductor Devices" in the reliability handbook, etc.), and ensure that usage conditions are within the ranges specified by Renesas Electronics with respect to maximum ratings, operating power supply voltage range, heat dissipation characteristics, installation, etc. Renesas Electronics disclaims any and all liability for any malfunctions, failure or accident arising out of the use of Renesas Electronics products outside of such specified ranges.
7. Although Renesas Electronics endeavors to improve the quality and reliability of Renesas Electronics products, semiconductor products have specific characteristics, such as the occurrence of failure at a certain rate and malfunctions under certain use conditions. Unless designated as a high reliability product or a product for harsh environments in a Renesas Electronics data sheet or other Renesas Electronics document, Renesas Electronics products are not subject to radiation resistance design. You are responsible for implementing safety measures to guard against the possibility of bodily injury, injury or damage caused by fire, and/or danger to the public in the event of a failure or malfunction of Renesas Electronics products, such as safety design for hardware and software, including but not limited to redundancy, fire control and malfunction prevention, appropriate treatment for aging degradation or any other appropriate measures. Because the evaluation of microcomputer software alone is very difficult and impractical, you are responsible for evaluating the safety of the final products or systems manufactured by you.
8. Please contact a Renesas Electronics sales office for details as to environmental matters such as the environmental compatibility of each Renesas Electronics product. You are responsible for carefully and sufficiently investigating applicable laws and regulations that regulate the inclusion or use of controlled substances, including without limitation, the EU RoHS Directive, and using Renesas Electronics products in compliance with all these applicable laws and regulations. Renesas Electronics disclaims any and all liability for damages or losses occurring as a result of your noncompliance with applicable laws and regulations.
9. Renesas Electronics products and technologies shall not be used for or incorporated into any products or systems whose manufacture, use, or sale is prohibited under any applicable domestic or foreign laws or regulations. You shall comply with any applicable export control laws and regulations promulgated and administered by the governments of any countries asserting jurisdiction over the parties or transactions.
10. It is the responsibility of the buyer or distributor of Renesas Electronics products, or any other party who distributes, disposes of, or otherwise sells or transfers the product to a third party, to notify such third party in advance of the contents and conditions set forth in this document.
11. This document shall not be reprinted, reproduced or duplicated in any form, in whole or in part, without prior written consent of Renesas Electronics.
12. Please contact a Renesas Electronics sales office if you have any questions regarding the information contained in this document or Renesas Electronics products.

(Note1) "Renesas Electronics" as used in this document means Renesas Electronics Corporation and also includes its directly or indirectly controlled subsidiaries.

(Note2) "Renesas Electronics product(s)" means any product developed or manufactured by or for Renesas Electronics.

(Rev.4.0-1 November 2017)

Corporate Headquarters

TOYOSU FORESIA, 3-2-24 Toyosu,
Koto-ku, Tokyo 135-0061, Japan
www.renesas.com

Contact Information

For further information on a product, technology, the most up-to-date version of a document, or your nearest sales office, please visit:
www.renesas.com/contact/

Trademarks

Renesas and the Renesas logo are trademarks of Renesas Electronics Corporation. All trademarks and registered trademarks are the property of their respective owners.