

# 8-bit serial/parallel register with sign extend (3-State)

# 74F322

## FEATURES

- Multiplexed parallel I/O ports
- Separate serial input and output
- Sign extend function
- 3-State outputs for bus applications
- Direct Overriding Clear

## DESCRIPTION

The 74F322 is an 8-bit shift register with provision for either serial or parallel loading and with 3-State parallel outputs plus a bi-state serial output. Parallel data inputs and outputs are multiplexed to minimize pin count. State changes are initiated by the rising edge of the clock. Four synchronous modes of operation are possible: hold (store), shift right with serial entry, shift right with sign extend, and parallel load. An asynchronous Master Reset ( $\overline{MR}$ ) input overrides clocked operation and clears the registers.

The 74F322 contains eight D-type edge triggered flip-flops and the interstage gating required to perform right shift and the intrastage gating necessary for hold and synchronous parallel load operations. A Low signal on  $\overline{RE}$  enables shifting or parallel loading, while a High signal enables the hold mode. A High signal on  $S/\overline{P}$  enables shift right, while a Low signal disables the 3-State output buffers and enables parallel loading. In the shift right mode a High signal on  $\overline{SE}$  enables serial entry from either D0 or D1, as determined by the S input. A Low signal on  $\overline{SE}$  enables shift right, but Q7 reloads its contents, thus performing the sign extend function. A High signal on  $\overline{OE}$  disables the 3-State output buffers, regardless of the other control inputs. In this condition the shifting and loading operations can still be performed.

## PIN CONFIGURATION

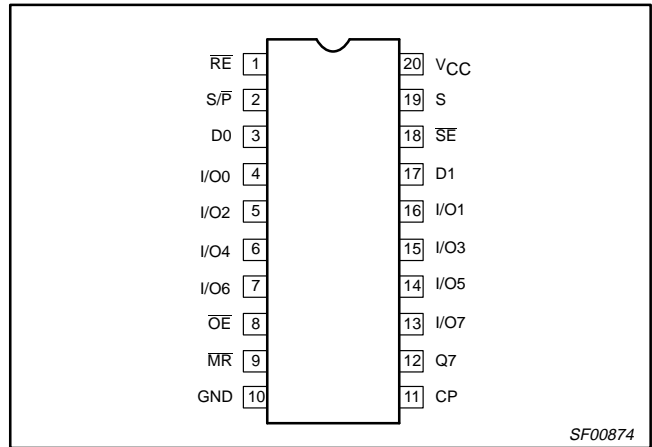

TYPE	TYPICAL $f_{MAX}$	TYPICAL SUPPLY CURRENT (TOTAL)
74F322	125MHz	60mA

## ORDERING INFORMATION

DESCRIPTION	ORDER CODE
	COMMERCIAL RANGE $V_{CC} = 5V \pm 10\%$ , $T_{amb} = 0^{\circ}C$ to $+70^{\circ}C$
20-pin plastic DIP	N74F322N
20-pin plastic SOL	N74F322D

## INPUT AND OUTPUT LOADING AND FAN-OUT TABLE

PINS	DESCRIPTION	74F(U.L.) HIGH/LOW	LOAD VALUE HIGH/LOW
D0, D1	Serial data inputs	1.0/1.0	20 $\mu$ A/0.6mA
S	Serial data select input	1.0/2.0	20 $\mu$ A/1.2mA
$\overline{SE}$	Sign Extend input	1.0/3.0	20 $\mu$ A/1.8mA
CP	Clock Pulse input (Active rising edge)	1.0/1.0	20 $\mu$ A/0.6mA
$S/\overline{P}$	Serial (High) or Parallel (Low) mode control input	1.0/1.0	20 $\mu$ A/0.6mA
$\overline{RE}$	Register Enable input (Active Low)	1.0/1.0	20 $\mu$ A/0.6mA
$\overline{MR}$	Asynchronous Master Reset input (Active Low)	1.0/1.0	20 $\mu$ A/0.6mA
$\overline{OE}$	Output Enable input (Active Low)	1.0/1.0	20 $\mu$ A/0.6mA
Q7	Bi-state serial output	50/33	1.0mA/20mA
I/On	Multiplexed parallel data inputs or	3.5/1.0	70 $\mu$ A/0.6mA
	3-State parallel outputs	150/40	3.0mA/24mA

**NOTE:** One (1.0) FAST Unit Load (U.L.) is defined as: 20 $\mu$ A in the High State and 0.6mA in the Low state.

# 8-bit serial/parallel register with sign extend (3-State)

74F322

## LOGIC SYMBOL

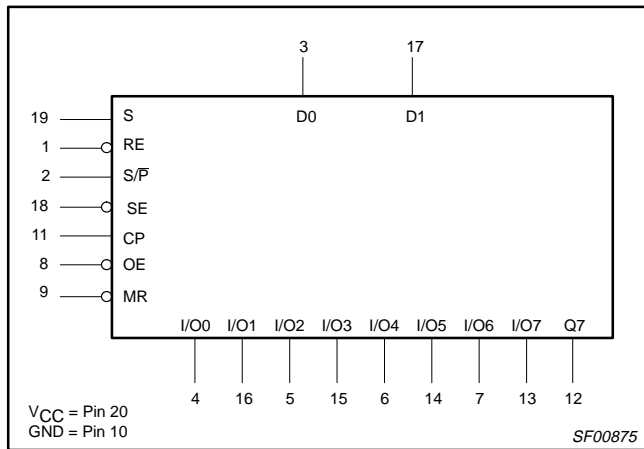

## LOGIC SYMBOL (IEEE/IEC)

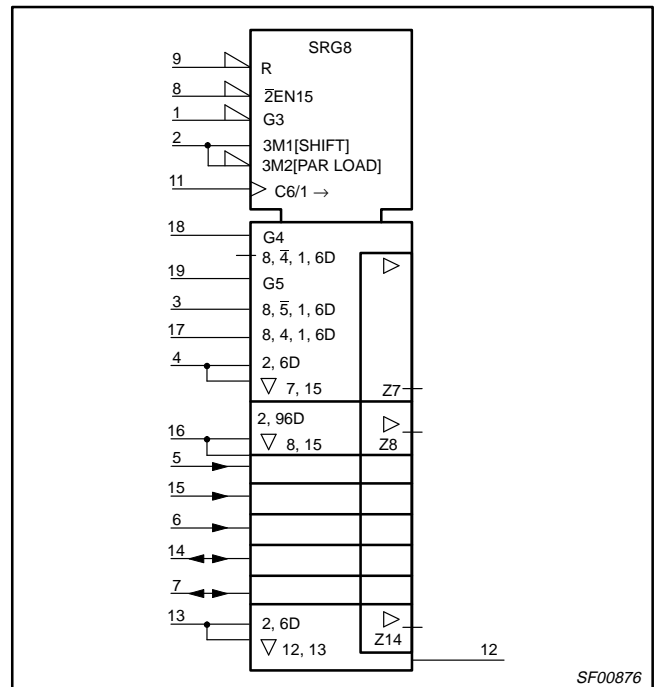

## FUNCTION TABLE

INPUTS							INPUTS									OPERATING MODE
MR	RE	S/P	SE	S	OE*	CP	I/O0	I/O1	I/O2	I/O3	I/O4	I/O5	I/O6	I/O7	Q7	
L	H	X	X	X	L	X	L	L	L	L	L	L	L	L	L	Clear
L	X	H	X	X	L	X	L	L	L	L	L	L	L	L	L	
H	L	L	X	X	X	↑	I0	I1	I2	I3	I4	I5	I6	I7	I7	Parallel load
H	L	H	H	L	L	↑	D0	O0	O1	O2	O3	O4	O5	O6	O6	Shift right
H	L	H	H	H	L	↑	D1	O0	O1	O2	O3	O4	O5	O6	O6	
H	L	H	L	X	L	↑	O0	O0	O1	O2	O3	O4	O5	O6	O6	Sign extend
H	H	X	X	X	L	X	NC	NC	NC	NC	NC	NC	NC	NC	NC	Hold
X	L	L	X	X	X	X	Z	Z	Z	Z	Z	Z	Z	Z	Z	3-State
X	X	X	X	X	H	↑	Z	Z	Z	Z	Z	Z	Z	Z	Z	NC
							Z	Z	Z	Z	Z	Z	Z	Z	Z	NC

\* = When the input is High, all I/O terminals are at the high impedance state, sequential operation or clearing of the register is not affected.

H = High voltage level

L = Low voltage level

NC = No change

X = Don't care

Z = High impedance "off" state

↑ = Low-to-High clock transition

I0-I7 = The level of the steady state input at the respective I/O terminal is loaded into the flip-flop while the flip-flop outputs (except Q7) are isolated from the I/O terminal.

D0-D7 = The level of the steady state inputs to the serial multiplexer input.

O0-O7 = The level of the respective Qn flip-flop prior to the last clock Low-to-High transition.

↑ = Not a Low-to-High clock transition

# 8-bit serial/parallel register with sign extend (3-State)

74F322

## LOGIC DIAGRAM

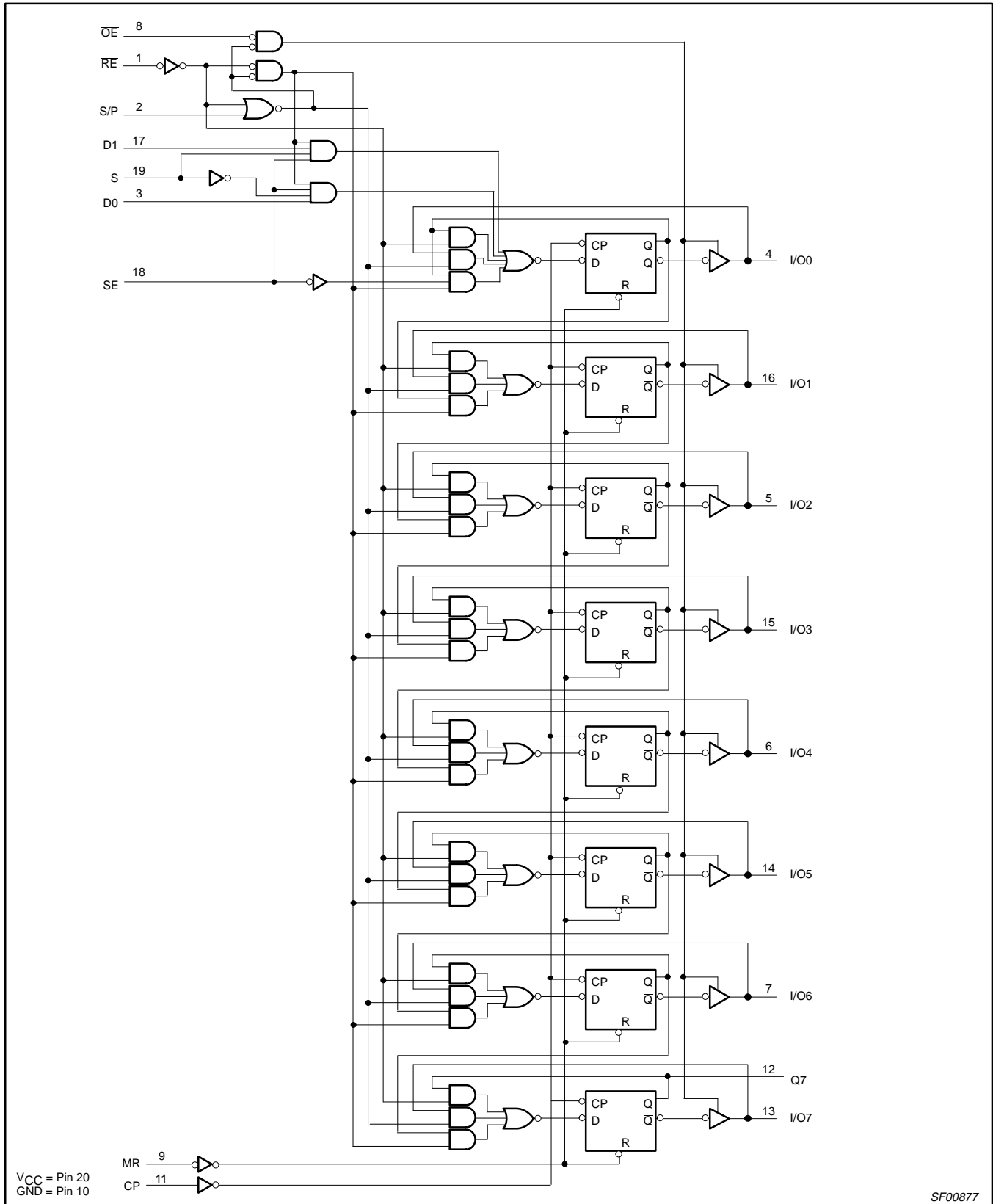

## 8-bit serial/parallel register with sign extend (3-State)

74F322

**ABSOLUTE MAXIMUM RATINGS**

(Operation beyond the limits set forth in this table may impair the useful life of the device. Unless otherwise noted these limits are over the operating free-air temperature range.)

SYMBOL	PARAMETER	RATING	UNIT	
$V_{CC}$	Supply voltage	-0.5 to +7.0	V	
$V_{IN}$	Input voltage	-0.5 to +7.0	V	
$I_{IN}$	Input current	-30 to +5	mA	
$V_{OUT}$	Voltage applied to output in High output state	-0.5 to +5.5	V	
$I_{OUT}$	Current applied to output in Low output state	Q7	40	mA
		I/On	48	mA
$T_{amb}$	Operating free-air temperature range	0 to +70	°C	
$T_{stg}$	Storage temperature	-65 to +150	°C	

**RECOMMENDED OPERATING CONDITIONS**

SYMBOL	PARAMETER	LIMITS			UNIT
		MIN	NOM	MAX	
$V_{CC}$	Supply voltage	4.5	5.0	5.5	V
$V_{IH}$	High-level input voltage	2.0			V
$V_{IL}$	Low-level input voltage			0.8	V
$I_{IK}$	Input clamp current			-18	mA
$I_{OH}$	High-level output current	Q7		-1	mA
		I/On		-3	mA
$I_{OL}$	Low-level output current	Q7		20	mA
		I/On		24	mA
$T_{amb}$	Operating free-air temperature range	0		70	°C

## 8-bit serial/parallel register with sign extend (3-State)

74F322

**DC ELECTRICAL CHARACTERISTICS**

(Over recommended operating free-air temperature range unless otherwise noted.)

SYMBOL	PARAMETER		TEST CONDITIONS <sup>1</sup>			LIMITS			UNIT
						MIN	TYP <sup>2</sup>	MAX	
V <sub>OH</sub>	High-level output voltage	Q7	V <sub>CC</sub> = MIN, V <sub>IL</sub> = MAX, V <sub>IH</sub> = MIN	I <sub>OH</sub> = -1mA	±10%V <sub>CC</sub>	2.5			V
					±5%V <sub>CC</sub>	2.7	3.4		V
		I/On		I <sub>OH</sub> = -3mA	±10%V <sub>CC</sub>	2.4			V
					±5%V <sub>CC</sub>	2.7	3.3		V
V <sub>OL</sub>	Low-level output voltage		V <sub>CC</sub> = MIN, V <sub>IL</sub> = MAX, V <sub>IH</sub> = MIN	I <sub>OL</sub> = MAX	±10%V <sub>CC</sub>		0.38	0.55	V
					±5%V <sub>CC</sub>		0.35	0.50	V
V <sub>IK</sub>	Input clamp voltage		V <sub>CC</sub> = MIN, I <sub>I</sub> = I <sub>IK</sub>				-0.73	-1.2	V
I <sub>I</sub>	Input current at maximum input voltage	others	V <sub>CC</sub> = MAX, V <sub>I</sub> = 7.0V					100	μA
		I/On	V <sub>CC</sub> = MAX, V <sub>I</sub> = 5.5V					1	mA
I <sub>IH</sub>	High-level input current		V <sub>CC</sub> = MAX, V <sub>I</sub> = 2.7V					20	μA
I <sub>IL</sub>	Low-level input current	SE	V <sub>CC</sub> = MAX, V <sub>I</sub> = 0.5V					-1.8	mA
		S						-1.2	mA
		others						-0.6	mA
I <sub>IH</sub> + I <sub>OZH</sub>	Off-state output current High-level voltage applied		V <sub>CC</sub> = MAX, V <sub>I</sub> = 2.7V					70	μA
I <sub>IL</sub> + I <sub>OZL</sub>	Off-state output current Low-level voltage applied		V <sub>CC</sub> = MAX, V <sub>I</sub> = 0.5V					-0.6	mA
I <sub>OS</sub>	Short-circuit output current <sup>3</sup>		V <sub>CC</sub> = MAX			-60		-150	mA
I <sub>CC</sub>	Supply current (total)	I <sub>CCH</sub>	V <sub>CC</sub> = MAX				50	75	mA
		I <sub>CCL</sub>					60	90	mA
		I <sub>CCZ</sub>					65	95	mA

**NOTES:**

- For conditions shown as MIN or MAX, use the appropriate value specified under recommended operating conditions for the applicable type.
- All typical values are at V<sub>CC</sub> = 5V, T<sub>amb</sub> = 25°C.
- Not more than one output should be shorted at a time. For testing I<sub>OS</sub>, the use of high-speed test apparatus and/or sample-and-hold techniques are preferable in order to minimize internal heating and more accurately reflect operational values. Otherwise, prolonged shorting of a High output may raise the chip temperature well above normal and thereby cause invalid readings in other parameter tests. In any sequence of parameter tests, I<sub>OS</sub> tests should be performed last.

## 8-bit serial/parallel register with sign extend (3-State)

74F322

## AC ELECTRICAL CHARACTERISTICS

SYMBOL	PARAMETER	TEST CONDITIONS	LIMITS					UNIT
			T <sub>amb</sub> = +25°C V <sub>CC</sub> = +5.0V C <sub>L</sub> = 50pF, R <sub>L</sub> = 500Ω			T <sub>amb</sub> = 0°C to +70°C V <sub>CC</sub> = +5.0V ± 10% C <sub>L</sub> = 50pF, R <sub>L</sub> = 500Ω		
			MIN	TYP	MAX	MIN	MAX	
f <sub>MAX</sub>	Maximum clock frequency	Waveform 1	110	125		90		MHz
t <sub>PLH</sub> t <sub>PHL</sub>	Propagation delay CP to I/On	Waveform 1	4.0 4.5	6.0 7.0	9.0 9.5	4.0 4.5	10.0 10.0	ns ns
t <sub>PLH</sub> t <sub>PHL</sub>	Propagation delay CP to Q7	Waveform 1	4.5 5.0	6.5 6.5	9.0 9.0	4.5 5.0	10.0 9.0	ns ns
t <sub>PHL</sub>	Propagation delay MR to I/On	Waveform 2	5.0	6.5	9.5	4.5	10.0	ns
t <sub>PHL</sub>	Propagation delay MR to Q7	Waveform 2	5.0	6.5	9.5	4.5	10.0	ns
t <sub>PZH</sub> t <sub>PZL</sub>	Output Enable time OE to I/On	Waveform 4 Waveform 5	3.0 5.5	5.0 7.5	8.0 10.5	3.0 5.0	9.0 11.0	ns ns
t <sub>PHZ</sub> t <sub>PLZ</sub>	Output Disable time OE to I/On	Waveform 4 Waveform 5	2.0 1.0	4.0 2.5	6.5 5.5	2.0 1.0	7.5 6.0	ns ns
t <sub>PZH</sub> t <sub>PZL</sub>	Output Disable time S/P to I/On	Waveform 4 Waveform 5	4.0 6.0	6.0 8.0	9.0 11.0	3.5 5.5	10.0 11.5	ns ns
t <sub>PHZ</sub> t <sub>PLZ</sub>	Output Disable time S/P to I/On	Waveform 4 Waveform 5	4.0 2.0	6.0 4.0	9.0 7.0	3.5 2.0	10.5 7.5	ns ns
t <sub>PZH</sub> t <sub>PZL</sub>	Output Disable time RE to I/On	Waveform 4 Waveform 5	8.0 9.0	9.5 11.0	12.5 14.0	7.0 8.0	14.0 16.0	ns ns
t <sub>PHZ</sub> t <sub>PLZ</sub>	Output Disable time RE to I/On	Waveform 4 Waveform 5	6.5 4.5	8.5 6.5	11.5 9.5	5.5 4.0	13.0 10.5	ns ns

## 8-bit serial/parallel register with sign extend (3-State)

74F322

## AC SETUP REQUIREMENTS

SYMBOL	PARAMETER	TEST CONDITIONS	LIMITS					UNIT
			T <sub>amb</sub> = +25°C V <sub>CC</sub> = +5.0V C <sub>L</sub> = 50pF, R <sub>L</sub> = 500Ω			T <sub>amb</sub> = 0°C to +70°C V <sub>CC</sub> = +5.0V ± 10% C <sub>L</sub> = 50pF, R <sub>L</sub> = 500Ω		
			MIN	TYP	MAX	MIN	MAX	
t <sub>s</sub> (H) t <sub>s</sub> (L)	Setup time, High or Low RE to CP	Waveform 3	8.0 12.5			9.5 14.0		ns ns
t <sub>h</sub> (H) t <sub>h</sub> (L)	Hold time, High or Low RE to CP	Waveform 3	0 0			0 0		ns ns
t <sub>s</sub> (H) t <sub>s</sub> (L)	Setup time, High or Low D0, D1 or I/On to CP	Waveform 3	4.0 4.5			6.0 5.0		ns ns
t <sub>h</sub> (H) t <sub>h</sub> (L)	Hold time, High or Low D0, D1 or I/On to CP	Waveform 3	0 0			0 0		ns ns
t <sub>s</sub> (H) t <sub>s</sub> (L)	Setup time, High or Low SE to CP	Waveform 3	5.5 5.0			7.0 5.5		ns ns
t <sub>h</sub> (H) t <sub>h</sub> (L)	Hold time, High or Low SE to CP	Waveform 3	0 0			0 0		ns ns
t <sub>s</sub> (H) t <sub>s</sub> (L)	Setup time, High or Low S/P to CP	Waveform 3	10.5 9.5			11.0 10.5		ns ns
t <sub>s</sub> (H) t <sub>s</sub> (L)	Setup time, High or Low S to CP	Waveform 3	4.0 8.5			4.5 9.5		ns ns
t <sub>h</sub> (H) t <sub>h</sub> (L)	Hold time, High or Low S or S/P to CP	Waveform 3	0 0			0 0		ns ns
t <sub>w</sub> (H) t <sub>w</sub> (L)	CP Pulse width, High or Low	Waveform 3	5.0 5.0			5.0 5.0		ns
t <sub>w</sub> (L)	MR Pulse width, Low	Waveform 3	5.0			5.0		ns
t <sub>REC</sub>	Recovery time, MR to CP	Waveform 2	4.0			4.5		ns

# 8-bit serial/parallel register with sign extend (3-State)

74F322

## AC WAVEFORMS

For all waveforms,  $V_M = 1.5V$

The shaded areas indicate when the input is permitted to change for predictable output performance.

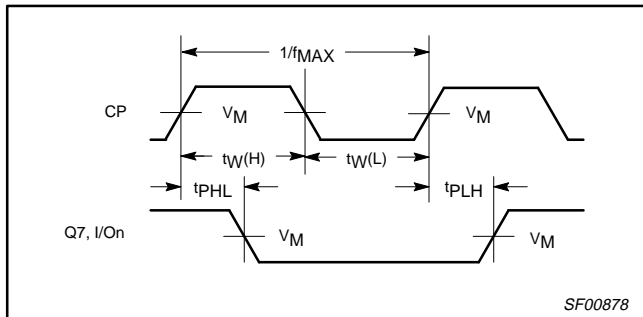

**Waveform 1. Propagation Delay, Clock Input to Output, Clock Pulse Width, and Maximum Clock Frequency**

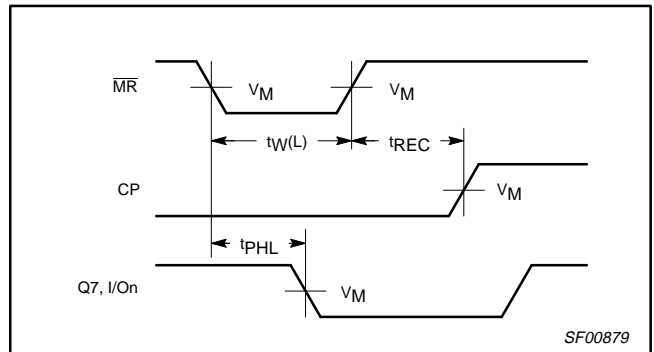

**Waveform 2. Master Reset Pulse Width, Master Reset to Output Delay, and Master Reset to Clock Recovery Time**

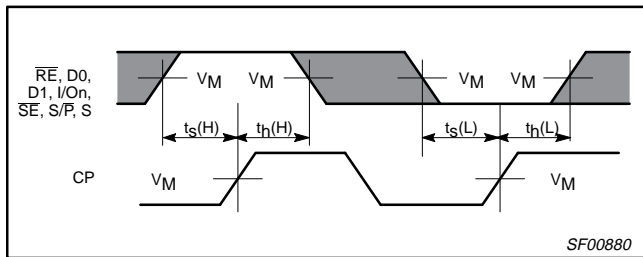

**Waveform 3. Data Setup and Hold Times**

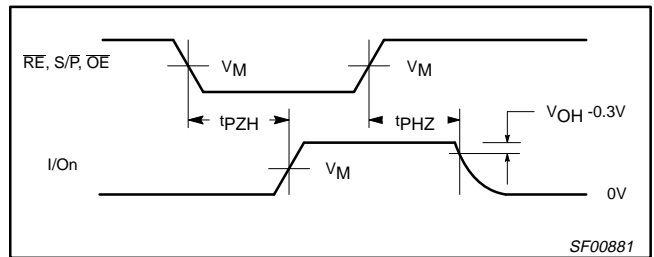

**Waveform 4. 3-State Output Enable Time to High Level and Output Disable Time from High Level**

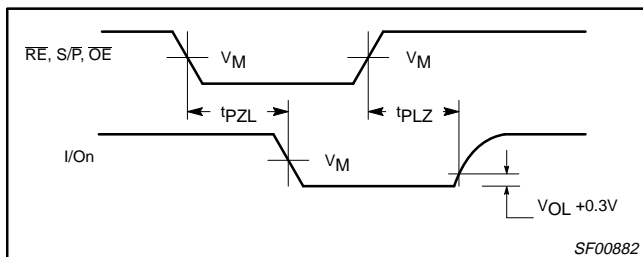

**Waveform 5. 3-State Output Enable Time to Low Level and Output Disable Time from Low Level**



# 8-bit serial/parallel register with sign extend (3-State)

74F322

## TEST CIRCUIT AND WAVEFORM

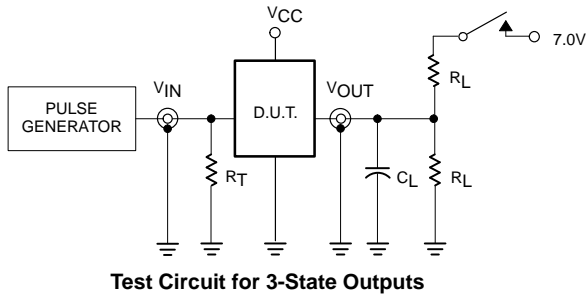

Test Circuit for 3-State Outputs

### SWITCH POSITION

TEST	SWITCH
$t_{PLZ}$	closed
$t_{PZL}$	closed
All other	open

### DEFINITIONS:

- $R_L$  = Load resistor; see AC electrical characteristics for value.
- $C_L$  = Load capacitance includes jig and probe capacitance; see AC electrical characteristics for value.
- $R_T$  = Termination resistance should be equal to  $Z_{OUT}$  of pulse generators.

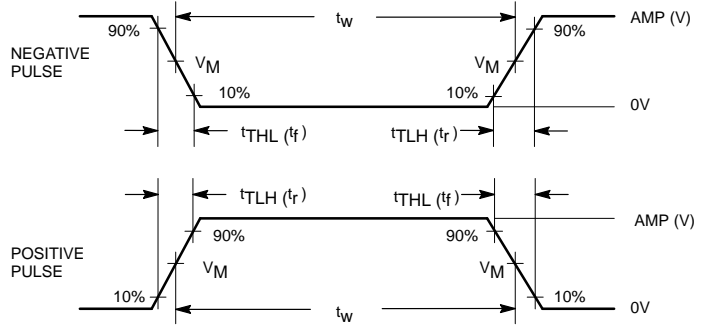

Input Pulse Definition

family	INPUT PULSE REQUIREMENTS					
	amplitude	$V_M$	rep. rate	$t_w$	$t_{TLH}$	$t_{THL}$
74F	3.0V	1.5V	1MHz	500ns	2.5ns	2.5ns

SF00777