

DATA SHEET

74HC/HCT9323A

Programmable ripple counter with
oscillator (3-State)

Objective specification

1995 Oct 27

IC06 Data Handbook

Programmable ripple counter with oscillator (3-State)

74HC/HCT9323A

FEATURES

- 8-pin space saving package
- Programmable 3-stage ripple counter
- Suitable for over-tone crystal application up to 85MHz ($V_{CC} = 5V \pm 10\%$)
- 3-State output buffer
- Two internal capacitors
- Recommended operating range for use with third overtone crystals 3V to 6V
- Oscillator stop function (\overline{MR})
- Output capability:
bus driver \rightarrow (15 LSTTL)
- I_{CC} category: MSI

APPLICATIONS

- Control counters
- Timers
- Frequency dividers
- Time-delay circuits
- CIO (Compact Integrated Oscillator)
- Third-overtone crystal operation

DESCRIPTION

The 74HC/HCT9323A are high-speed Si-gate CMOS devices. They are specified in compliance with JEDEC standard no. 7A.

The HC/HCT 9323A are oscillators designed for quartz crystal combined with a programmable 3-State counter, a 3-State output buffer and an overriding asynchronous master reset (\overline{MR}). With the two select inputs S1 and S2 the counter can be switched in the divide-1, 2, 4 or 8 mode. If left floating the clock is divided by 8. The oscillator is designed to operate either in the fundamental or third overtone mode depending on the crystal and external components applied. On-chip capacitors minimize external component count for third overtone crystal applications.

The oscillator may be replaced by an external clock signal at input X1. In this event the other oscillator pin (X2) must be floating. The counter advances on the negative-going transition of X1. A LOW level on \overline{MR} resets the counter, stops the oscillator and sets the output buffer in the 3-State condition. \overline{MR} can be left floating since an internal pull-up resistor will make the \overline{MR} inactive. In the HCT version, the \overline{MR} input and the two mode select pins S1 and S2 are TTL compatible, but the X1 input has CMOS input switching levels and may be driven by a TTL output using a pull-up resistor connected to V_{CC} .

QUICK REFERENCE DATA

GND = 0V; $T_{amb} = 25^{\circ}\text{C}$, $t_r = t_f = 6\text{ns}$

SYMBOL	PARAMETER	CONDITIONS $T_{amb} = 25^{\circ}\text{C}$; GND = 0V	TYPICAL		UNIT
			HC	HCT	
t_{PLH} t_{PHL}	Propagation delay X1 to OUT (S1 = S2 = LOW)	$C_L = 50\text{pF}$; $V_{CC} = 5\text{V}$	8	8	ns
f_{max}	Maximum clock frequency		150	150	MHz
C_I	Input capacitance except X1 and X2		3.5	3.5	pF
C_{PD}	Power dissipation capacitance per package				pF

NOTES:

C_{PD} is used to determine the dynamic power dissipation (P_D in μW):

$$P_D = (C_{PD} \times V_{CC}^2 \times f_i) + (C_L + V_{CC}^2 \times f_O) + (I_{pull-up} \times V_{CC})$$

where:

f_i = input frequency in MHz..

f_O = output frequency in MHz.

V_{CC} = Supply voltage in V.

C_L = Output load capacitance in pF.

$I_{pull-up}$ = Pull-up currents in μA .

For HC and HCT an external clock is applied to X1 with:

$t_r = t_f \leq 6\text{ns}$, V_I is GND to V_{CC} , $\overline{MR} = \text{HIGH}$.

$I_{pull-up}$ is the summation of $-I_I$ (μA) of S1 and S2 inputs at the LOW state.

ORDERING INFORMATION

PACKAGES	TEMPERATURE RANGE	ORDER NUMBER	DWG NUMBER
8-Pin Plastic SO	0°C to $+70^{\circ}\text{C}$	74HC/HCT9323A D	SOT96-1

Programmable ripple counter with oscillator (3-State)

74HC/HCT9323A

PIN CONFIGURATION

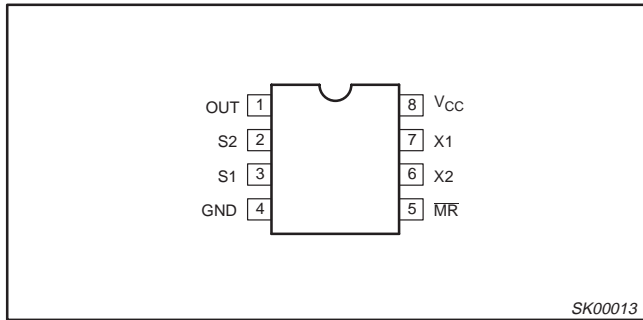

IEC LOGIC SYMBOL

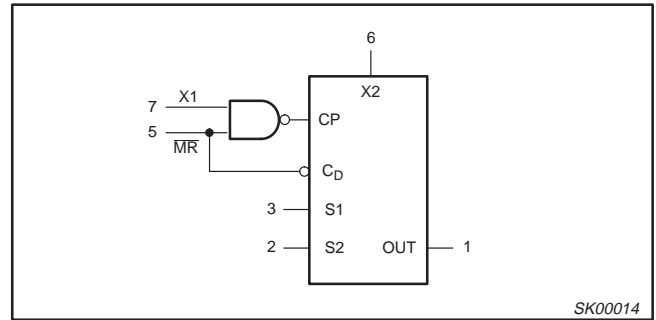

PIN DESCRIPTION

PIN NUMBER	SYMBOL	FUNCTION
1	OUT	Counter output
3, 2	S1-S2	Mode select inputs for divide by 1, 2, 4 or 8
4	GND	Ground (0V)
5	MR	Master reset (active LOW)
6	X2	Oscillator pin
7	X1	Clock input/oscillator pin
8	V _{CC}	Positive supply voltage

FUNCTION TABLE

INPUTS		OUTPUTS
S1	S2	OUT
0	0	f _i
0	1	f _i /2
1	0	f _i /4
1	1	f _i /8

FUNCTIONAL DIAGRAM

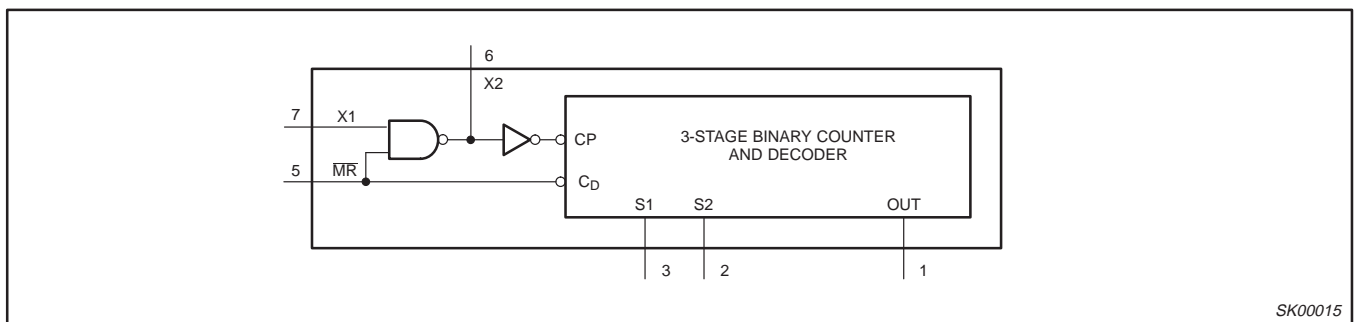

Programmable ripple counter with oscillator (3-State)

74HC/HCT9323A

LOGIC DIAGRAM

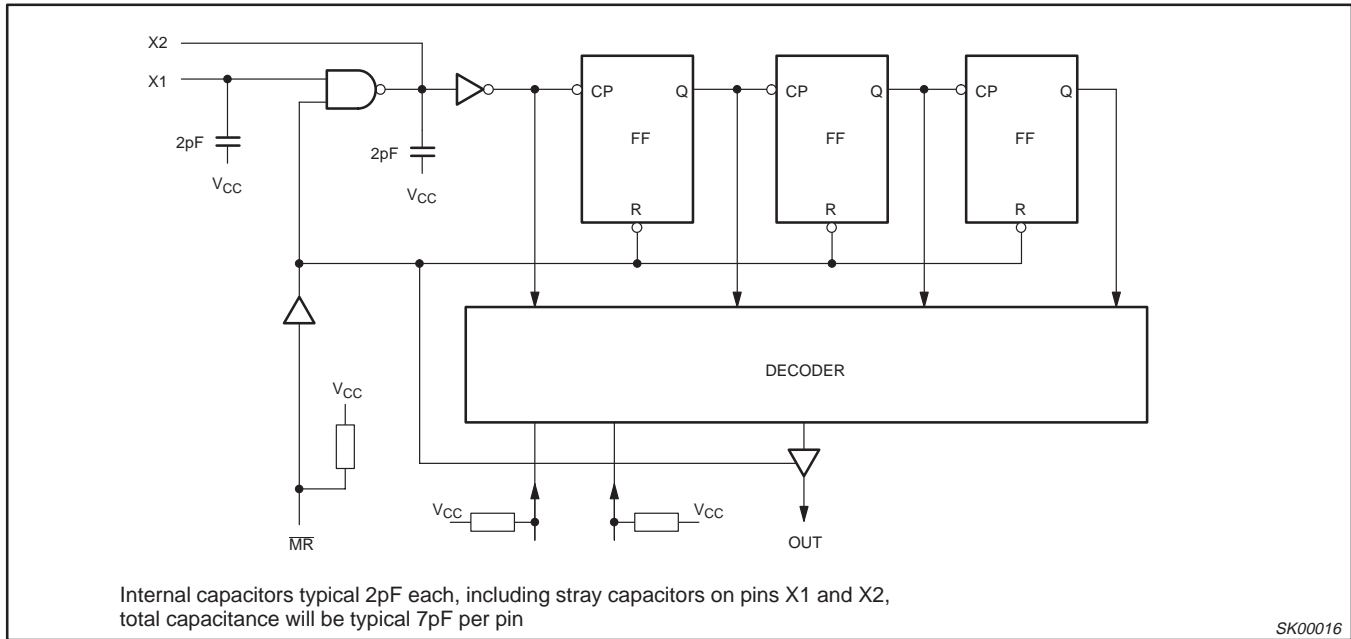

Programmable ripple counter with oscillator (3-State)

74HC/HCT9323A

SO8: plastic small outline package; 8 leads; body width 3.9mm

SOT96-1

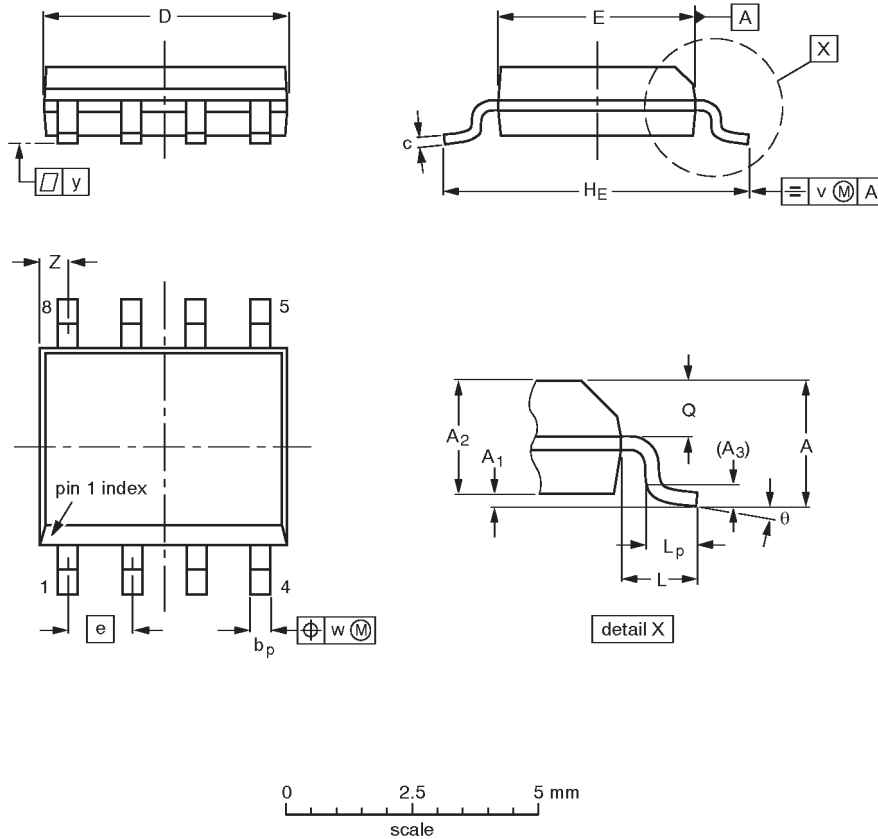

DIMENSIONS (inch dimensions are derived from the original mm dimensions)

UNIT	A max.	A ₁	A ₂	A ₃	b _p	c	D ⁽¹⁾	E ⁽²⁾	e	H _E	L	L _p	Q	v	w	y	Z ⁽¹⁾	θ
mm	1.75	0.25 0.10	1.45 1.25	0.25	0.49 0.36	0.25 0.19	5.0 4.8	4.0 3.8	1.27	6.2 5.8	1.05	1.0 0.4	0.7 0.6	0.25	0.25	0.1	0.7 0.3	8°
inches	0.069	0.0098 0.0039	0.057 0.049	0.01	0.019 0.014	0.0098 0.0075	0.20 0.19	0.16 0.15	0.050	0.24 0.23	0.041	0.039 0.016	0.028 0.024	0.01	0.01	0.004	0.028 0.012	0°

Notes

1. Plastic or metal protrusions of 0.15 mm maximum per side are not included.
2. Plastic or metal protrusions of 0.25 mm maximum per side are not included.

OUTLINE VERSION	REFERENCES				EUROPEAN PROJECTION	ISSUE DATE
	IEC	JEDEC	EIAJ			
SOT96-1	076E03S	MS-012AA				92-11-17 95-02-04

Programmable ripple counter with oscillator (3-State)

74HC/HCT9323A

DEFINITIONS

Data Sheet Identification	Product Status	Definition
<i>Objective Specification</i>	Formative or in Design	This data sheet contains the design target or goal specifications for product development. Specifications may change in any manner without notice.
<i>Preliminary Specification</i>	Preproduction Product	This data sheet contains preliminary data, and supplementary data will be published at a later date. Philips Semiconductors reserves the right to make changes at any time without notice in order to improve design and supply the best possible product.
<i>Product Specification</i>	Full Production	This data sheet contains Final Specifications. Philips Semiconductors reserves the right to make changes at any time without notice, in order to improve design and supply the best possible product.

Philips Semiconductors and Philips Electronics North America Corporation reserve the right to make changes, without notice, in the products, including circuits, standard cells, and/or software, described or contained herein in order to improve design and/or performance. Philips Semiconductors assumes no responsibility or liability for the use of any of these products, conveys no license or title under any patent, copyright, or mask work right to these products, and makes no representations or warranties that these products are free from patent, copyright, or mask work right infringement, unless otherwise specified. Applications that are described herein for any of these products are for illustrative purposes only. Philips Semiconductors makes no representation or warranty that such applications will be suitable for the specified use without further testing or modification.

LIFE SUPPORT APPLICATIONS

Philips Semiconductors and Philips Electronics North America Corporation Products are not designed for use in life support appliances, devices, or systems where malfunction of a Philips Semiconductors and Philips Electronics North America Corporation Product can reasonably be expected to result in a personal injury. Philips Semiconductors and Philips Electronics North America Corporation customers using or selling Philips Semiconductors and Philips Electronics North America Corporation Products for use in such applications do so at their own risk and agree to fully indemnify Philips Semiconductors and Philips Electronics North America Corporation for any damages resulting from such improper use or sale.

Philips Semiconductors
811 East Arques Avenue
P.O. Box 3409
Sunnyvale, California 94088-3409
Telephone 800-234-7381

Philips Semiconductors and Philips Electronics North America Corporation register eligible circuits under the Semiconductor Chip Protection Act.
 © Copyright Philips Electronics North America Corporation 1995
 All rights reserved. Printed in U.S.A.