

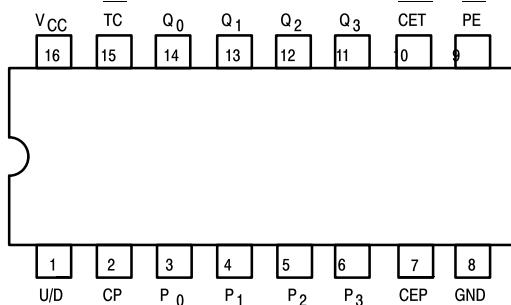


# BCD DECADE/MODULO 16 BINARY SYNCHRONOUS BI-DIRECTIONAL COUNTERS

The SN54/74LS168 and SN54/74LS169 are fully synchronous 4-stage up/down counters featuring a preset capability for programmable operation, carry lookahead for easy cascading and a U/D input to control the direction of counting. The SN54/74LS168 counts in a BCD decade (8, 4, 2, 1) sequence, while the SN54/74LS169 operates in a Modulo 16 binary sequence. All state changes, whether in counting or parallel loading, are initiated by the LOW-to-HIGH transition of the clock.

- Low Power Dissipation 100 mW Typical
- High-Speed Count Frequency 30 MHz Typical
- Fully Synchronous Operation
- Full Carry Lookahead for Easy Cascading
- Single Up/Down Control Input
- Positive Edge-Trigger Operation
- Input Clamp Diodes Limit High-Speed Termination Effects

CONNECTION DIAGRAM DIP (TOP VIEW)



NOTE:  
The Flatpak version has the same pinouts (Connection Diagram) as the Dual In-Line Package.

**PIN NAMES**

<u>CEP</u>	Count Enable Parallel (Active LOW) Input
<u>CET</u>	Count Enable Trickle (Active LOW) Input
<u>CP</u>	Clock Pulse (Active positive going edge) Input
<u>PE</u>	Parallel Enable (Active LOW) Input
<u>U/D</u>	Up-Down Count Control Input
<u>P<sub>0</sub>-P<sub>3</sub></u>	Parallel Data Inputs
<u>Q<sub>0</sub>-Q<sub>3</sub></u>	Flip-Flop Outputs
<u>TC</u>	Terminal Count (Active LOW) Output

**LOADING (Note a)**

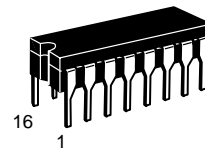
	HIGH	LOW
<u>CEP</u>	0.5 U.L.	0.25 U.L.
<u>CET</u>	1.0 U.L.	0.5 U.L.
<u>CP</u>	0.5 U.L.	0.25 U.L.
<u>PE</u>	0.5 U.L.	0.25 U.L.
<u>U/D</u>	0.5 U.L.	0.25 U.L.
<u>P<sub>0</sub>-P<sub>3</sub></u>	0.5 U.L.	0.25 U.L.
<u>Q<sub>0</sub>-Q<sub>3</sub></u>	10 U.L.	5 (2.5) U.L.
<u>TC</u>	10 U.L.	5 (2.5) U.L.

NOTES:

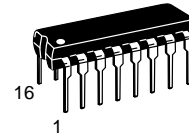
- a. 1 TTL Unit Load (U.L.) = 40  $\mu$ A HIGH/1.6 mA LOW.  
 b. The Output LOW drive factor is 2.5 U.L. for Military (54) and 5 U.L. for Commercial (74) Temperature Ranges.

**SN54/74LS168  
SN54/74LS169**

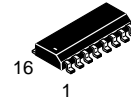
**BCD DECADE/MODULO  
16 BINARY SYNCHRONOUS  
BI-DIRECTIONAL COUNTERS**  
  
**LOW POWER SCHOTTKY**



**J SUFFIX  
CERAMIC  
CASE 620-09**



**N SUFFIX  
PLASTIC  
CASE 648-08**

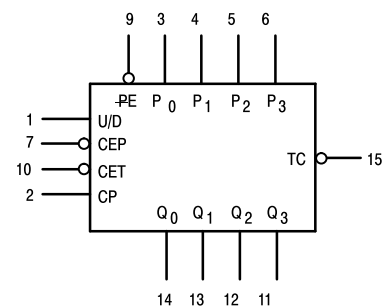


**D SUFFIX  
SOIC  
CASE 751B-03**

**ORDERING INFORMATION**

SN54LSXXXJ	Ceramic
SN74LSXXXN	Plastic
SN74LSXXXD	SOIC

**LOGIC SYMBOL**

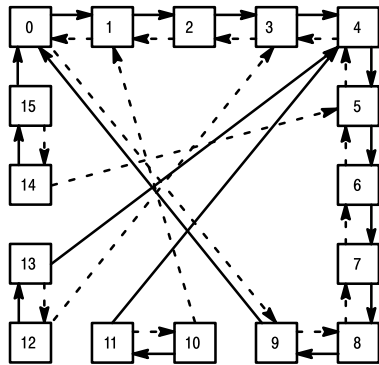


V<sub>CC</sub> = PIN 16  
GND = PIN 8

# SN54/74LS168 • SN54/74LS169

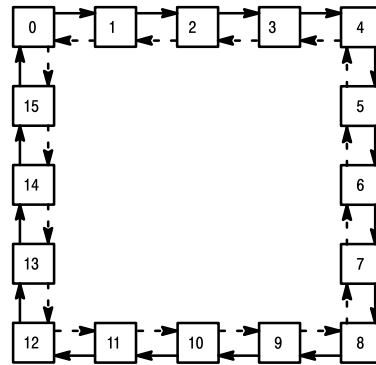
## STATE DIAGRAMS

**SN54/74LS168**  
UP/DOWN DECADE COUNTER



→ Count Up  
- - - Count Down

**SN54/74LS169**



**SN54/74LS168**

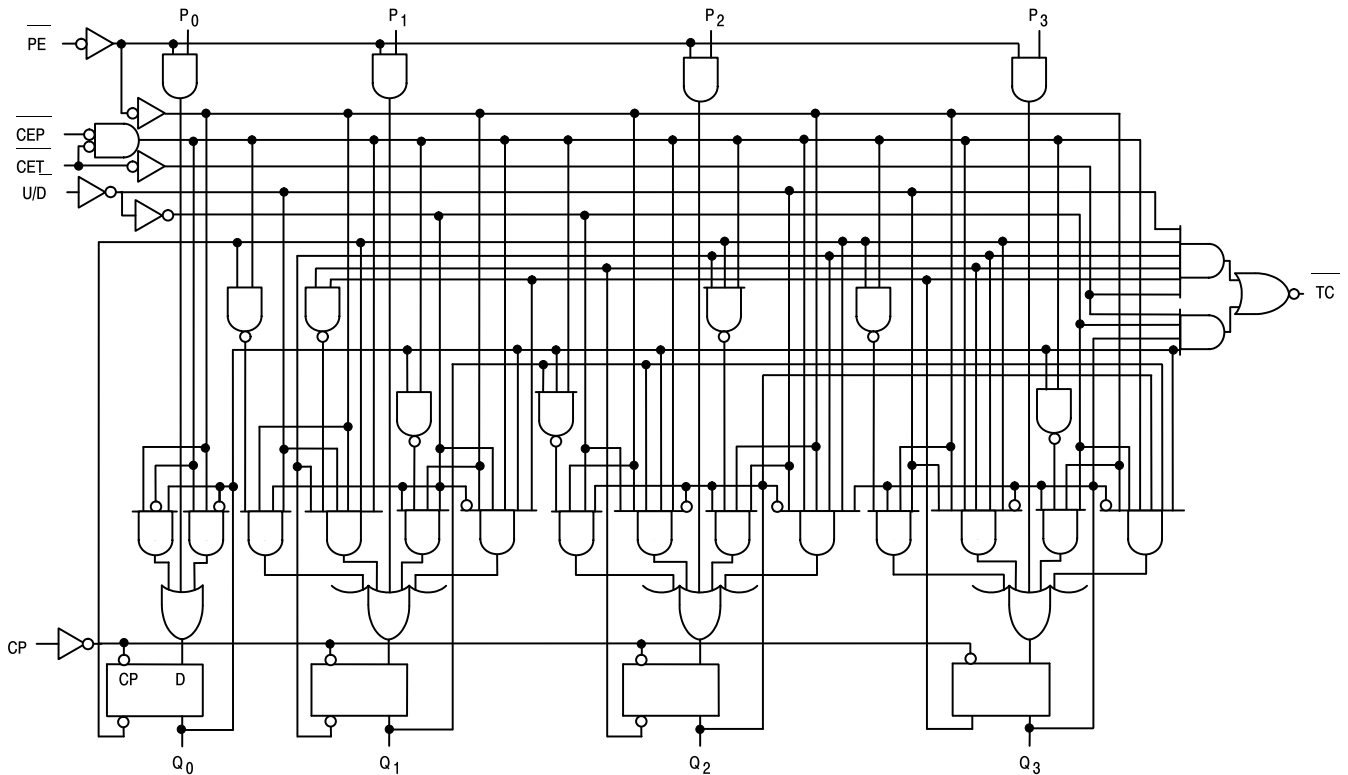
UP:  $TC = \overline{Q_0} \cdot \overline{Q_3} \cdot (U/D)$   
DOWN:  $TC = Q_0 \cdot Q_1 \cdot Q_2 \cdot Q_3 \cdot (U/D)$

**SN54/74LS169**

UP:  $TC = \overline{Q_0} \cdot \overline{Q_1} \cdot \overline{Q_2} \cdot \overline{Q_3} \cdot (U/D)$   
DOWN:  $TC = Q_0 \cdot Q_1 \cdot Q_2 \cdot Q_3 \cdot (U/D)$

## LOGIC DIAGRAMS

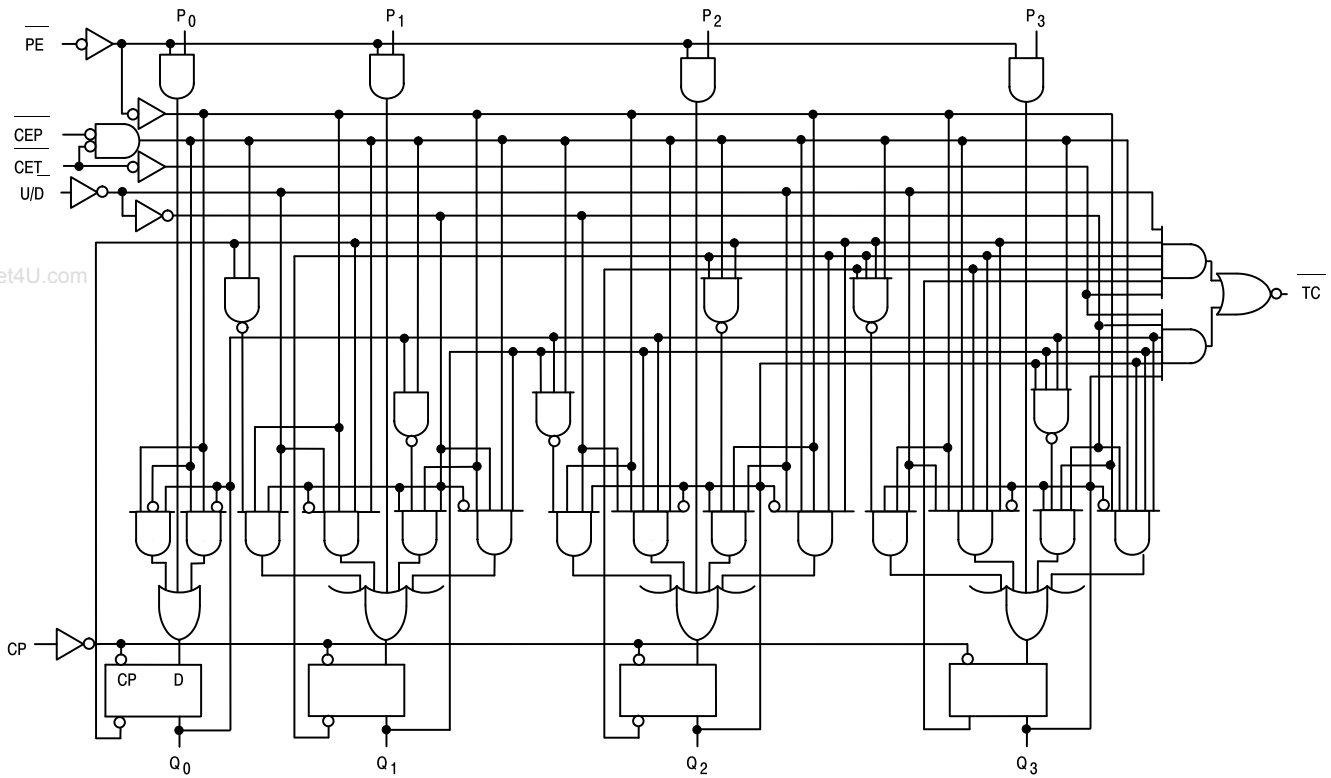
**SN54/74LS168**



# SN54/74LS168 • SN54/74LS169

## LOGIC DIAGRAMS (continued)

### SN54/74LS169



### GUARANTEED OPERATING RANGES

Symbol	Parameter		Min	Typ	Max	Unit
V <sub>CC</sub>	Supply Voltage	54	4.5	5.0	5.5	V
		74	4.75	5.0	5.25	
T <sub>A</sub>	Operating Ambient Temperature Range	54	-55	25	125	°C
		74	0	25	70	
I <sub>OH</sub>	Output Current — High	54, 74			-0.4	mA
I <sub>OL</sub>	Output Current — Low	54			4.0	mA
		74			8.0	

# SN54/74LS168 • SN54/74LS169

## DC CHARACTERISTICS OVER OPERATING TEMPERATURE RANGE (unless otherwise specified)

Symbol	Parameter		Limits			Unit	Test Conditions	
			Min	Typ	Max			
V <sub>IH</sub>	Input HIGH Voltage		2.0			V	Guaranteed Input HIGH Voltage for All Inputs	
V <sub>IL</sub>	Input LOW Voltage	54			0.7	V	Guaranteed Input LOW Voltage for All Inputs	
		74			0.8			
V <sub>IK</sub>	Input Clamp Diode Voltage			-0.65	-1.5	V	V <sub>CC</sub> = MIN, I <sub>IN</sub> = -18 mA	
V <sub>OH</sub>	Output HIGH Voltage	54	2.5	3.5		V	V <sub>CC</sub> = MIN, I <sub>OH</sub> = MAX, V <sub>IN</sub> = V <sub>IH</sub> or V <sub>IL</sub> per Truth Table	
		74	2.7	3.5		V		
V <sub>OL</sub>	Output LOW Voltage	54, 74		0.25	0.4	V	I <sub>OL</sub> = 4.0 mA	V <sub>CC</sub> = V <sub>CC</sub> MIN, V <sub>IN</sub> = V <sub>IL</sub> or V <sub>IH</sub> per Truth Table
		74		0.35	0.5	V		
I <sub>IH</sub>	Input HIGH Current Other Inputs CET Input				20 40	μA	V <sub>CC</sub> = MAX, V <sub>IN</sub> = 2.7 V	
	Other Input CET Input				0.1 0.2	mA	V <sub>CC</sub> = MAX, V <sub>IN</sub> = 7.0 V	
I <sub>IL</sub>	Input LOW Current Other Input CET Input				-0.4 -0.8	mA	V <sub>CC</sub> = MAX, V <sub>IN</sub> = 0.4 V	
I <sub>OS</sub>	Short Circuit Current (Note 1)		-20		-100	mA	V <sub>CC</sub> = MAX	
I <sub>CC</sub>	Power Supply Current				34	mA	V <sub>CC</sub> = MAX	

Note 1: Not more than one output should be shorted at one time, nor for more than 1 second.

## FUNCTIONAL DESCRIPTION

The SN54/74LS168 and SN54/74LS169 use edge-triggered D-type flip-flops that have no constraints on changing the control or data input signals in either state of the Clock. The only requirement is that the various inputs attain the desired state at least a set-up time before the rising edge of the clock and remain valid for the recommended hold time thereafter.

The parallel load operation takes precedence over the other operations, as indicated in the Mode Select Table. When PE is LOW, the data on the P<sub>0</sub>–P<sub>3</sub> inputs enters the flip-flops on the next rising edge of the Clock. In order for counting to occur, both CEP and CET must be LOW and PE must be HIGH. The U/D input then determines the direction of counting.

The Terminal Count (TC) output is normally HIGH and goes LOW, provided that CET is LOW, when a counter reaches zero in the COUNT DOWN mode or reaches 15 (9 for the SN54/74LS168) in the COUNT UP mode. The TC output state is not a function of the Count Enable Parallel (CEP) input level. The TC output of the SN54/74LS168 decade counter can also be LOW in the illegal states 11, 13 and 15, which can occur when power is turned on or via parallel loading. If illegal state occurs, the SN54/74LS168 will return to the legitimate sequence within two counts. Since the TC signal is derived by decoding the flip-flop states, there exists the possibility of decoding spikes on TC. For this reason the use of TC as a clock signal is not recommended.

## MODE SELECT TABLE

PE	CEP	CET	U/D	Action on Rising Clock Edge
L	X	X	X	Load (P <sub>n</sub> Q <sub>n</sub> )
H	L	L	H	Count Up (increment)
H	L	L	L	Count Down (decrement)
H	H	X	X	No Change (Hold)
H	X	H	X	No Change (Hold)

H = HIGH Voltage Level  
L = LOW Voltage Level  
X = Immaterial

## SN54/74LS168 • SN54/74LS169

### AC CHARACTERISTICS ( $T_A = 25^\circ\text{C}$ , $V_{CC} = 5.0\text{ V}$ )

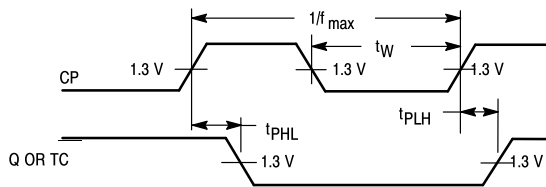
Symbol	Parameter	Limits			Unit	Test Conditions
		Min	Typ	Max		
f <sub>MAX</sub>	Maximum Clock Frequency	25	32		MHz	$V_{CC} = 5.0\text{ V}$ $C_L = 15\text{ pF}$
t <sub>PLH</sub> t <sub>PHL</sub>	Propagation Delay, Clock to TC		23 23	35 35	ns	
t <sub>PLH</sub> t <sub>PHL</sub>	Propagation Delay, Clock to any Q		13 15	20 23	ns	
t <sub>PLH</sub> t <sub>PHL</sub>	Propagation Delay, CET to TC		15 15	20 20	ns	
t <sub>PLH</sub> t <sub>PHL</sub>	Propagation Delay, U/D to TC		17 19	25 29	ns	

### AC SETUP REQUIREMENTS ( $T_A = 25^\circ\text{C}$ )

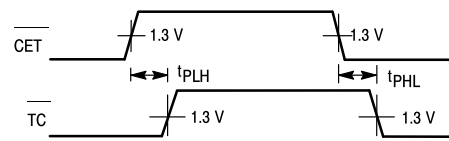
Symbol	Parameter	Limits			Unit	Test Conditions
		Min	Typ	Max		
t <sub>W</sub>	Clock Pulse Width	25			ns	$V_{CC} = 5.0\text{ V}$
t <sub>s</sub>	Setup Time, Data or Enable	20			ns	
t <sub>s</sub>	Setup Time PE	25			ns	
t <sub>s</sub>	Setup Time U/D	30			ns	
t <sub>h</sub>	Hold Time Any Input	0			ns	

# SN54/74LS168 • SN54/74LS169

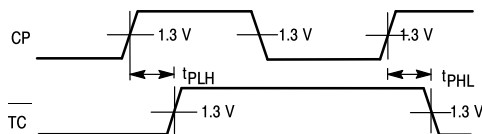
## AC WAVEFORMS



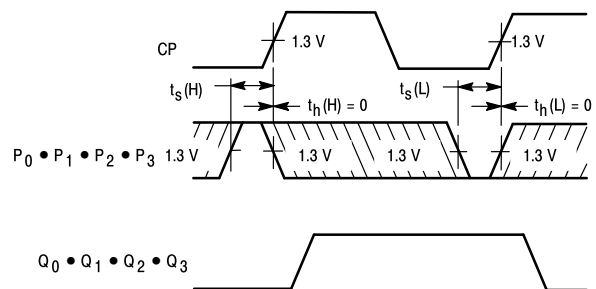
**Figure 1. Clock to Output Delays, Count Frequency, and Clock Pulse Width**



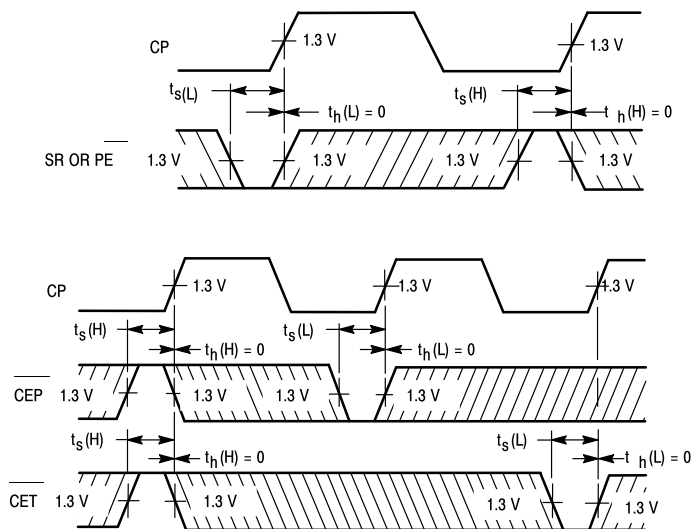
**Figure 2. Count Enable Trickle Input To Terminal Count Output Delays**



**Figure 3. Clock to Terminal Delays**

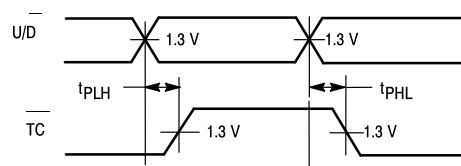


**Figure 4. Setup Time ( $t_s$ ) and Hold ( $t_h$ ) for Parallel Data Inputs**



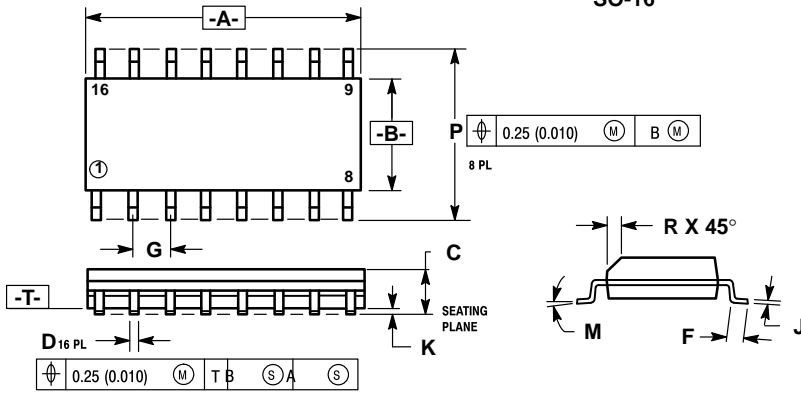
The shaded areas indicate when the input is permitted to change for predictable output performance.

**Figure 5. Setup Time and Hold Time for Count Enable and Parallel Enable Inputs, and Up-Down Control Inputs**



**Figure 6. Up-Down Input to Terminal Count Output Delays**

**Case 751B-03 D Suffix  
16-Pin Plastic  
SO-16**

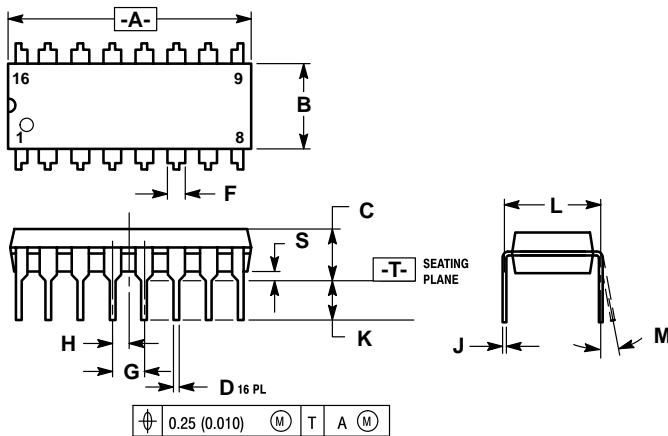


- NOTES:
1. DIMENSIONING AND TOLERANCING PER ANSI Y14.5M, 1982.
  2. CONTROLLING DIMENSION: MILLIMETER.
  3. DIMENSION A AND B DO NOT INCLUDE MOLD PROTRUSION.
  4. MAXIMUM MOLD PROTRUSION 0.15 (0.006) PER SIDE.
  5. 751B-01 IS OBSOLETE, NEW STANDARD 751B-03.

DIM	MILLIMETERS		INCHES	
	MIN	MAX	MIN	MAX
A	9.80	10.00	0.386	0.393
B	3.80	4.00	0.150	0.157
C	1.35	1.75	0.054	0.068
D	0.35	0.49	0.014	0.019
F	0.40	1.25	0.016	0.049
G	1.27 BSC		0.050 BSC	
J	0.19	0.25	0.008	0.009
K	0.10	0.25	0.004	0.009
M	0°	7°	0°	7°
P	5.80	6.20	0.229	0.244
R	0.25	0.50	0.010	0.019

www.DataSheet4U.com

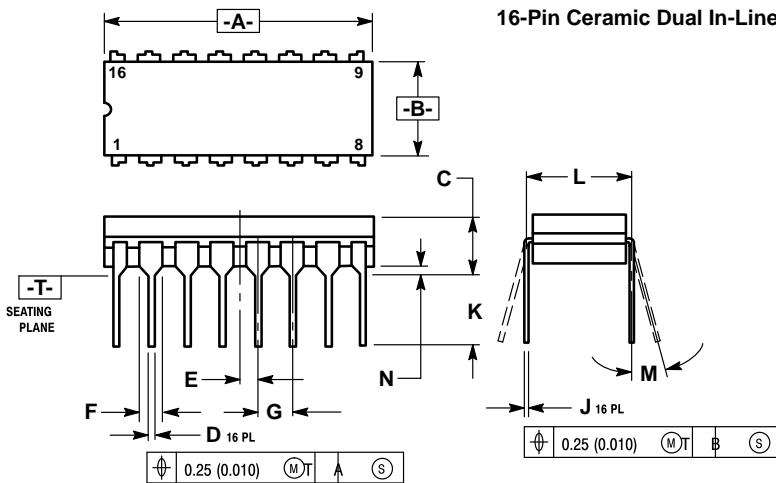
**Case 648-08 N Suffix  
16-Pin Plastic**



- NOTES:
1. DIMENSIONING AND TOLERANCING PER ANSI Y14.5M, 1982.
  2. CONTROLLING DIMENSION: INCH.
  3. DIMENSION "L" TO CENTER OF LEADS WHEN FORMED PARALLEL.
  4. DIMENSION "B" DOES NOT INCLUDE MOLD FLASH.
  5. ROUNDED CORNERS OPTIONAL.
  6. 648-01 THRU -07 OBSOLETE, NEW STANDARD 648-08.


DIM	MILLIMETERS		INCHES	
	MIN	MAX	MIN	MAX
A	18.80	19.55	0.740	0.770
B	6.35	6.85	0.250	0.270
C	3.69	4.44	0.145	0.175
D	0.39	0.53	0.015	0.021
F	1.02	1.77	0.040	0.070
G	2.54 BSC		0.100 BSC	
H	1.27 BSC		0.050 BSC	
J	0.21	0.38	0.008	0.015
K	2.80	3.30	0.110	0.130
L	7.50	7.74	0.295	0.305
M	0°	10°	0°	10°
S	0.51	1.01	0.020	0.040

**Case 620-09 J Suffix  
16-Pin Ceramic Dual In-Line**



- NOTES:
1. DIMENSIONING AND TOLERANCING PER ANSI Y14.5M, 1982.
  2. CONTROLLING DIMENSION: INCH.
  3. DIMENSION L TO CENTER OF LEAD WHEN FORMED PARALLEL.
  4. DIM F MAY NARROW TO 0.76 (0.030) WHERE THE LEAD ENTERS THE CERAMIC BODY.
  5. 620-01 THRU -08 OBSOLETE, NEW STANDARD 620-09.

DIM	MILLIMETERS		INCHES	
	MIN	MAX	MIN	MAX
A	19.05	19.55	0.750	0.770
B	6.10	7.36	0.240	0.290
C	—	4.19	—	0.165
D	0.39	0.53	0.015	0.021
E	1.27 BSC		0.050 BSC	
F	1.40	1.77	0.055	0.070
G	2.54 BSC		0.100 BSC	
J	0.23	0.27	0.009	0.011
K	—	5.08	—	0.200
L	7.62 BSC		0.300 BSC	
M	0°	15°	0°	15°
N	0.39	0.88	0.015	0.035

Motorola reserves the right to make changes without further notice to any products herein. Motorola makes no warranty, representation or guarantee regarding the suitability of its products for any particular purpose, nor does Motorola assume any liability arising out of the application or use of any product or circuit, and specifically disclaims any and all liability, including without limitation consequential or incidental damages. "Typical" parameters can and do vary in different applications. All operating parameters, including "Typicals" must be validated for each customer application by customer's technical experts. Motorola does not convey any license under its patent rights nor the rights of others. Motorola products are not designed, intended, or authorized for use as components in systems intended for surgical implant into the body, or other applications intended to support or sustain life, or for any other application in which the failure of the Motorola product could create a situation where personal injury or death may occur. Should Buyer purchase or use Motorola products for any such unintended or unauthorized application, Buyer shall indemnify and hold Motorola and its officers, employees, subsidiaries, affiliates, and distributors harmless against all claims, costs, damages, and expenses, and reasonable attorney fees arising out of, directly or indirectly, any claim of personal injury or death associated with such unintended or unauthorized use, even if such claim alleges that Motorola was negligent regarding the design or manufacture of the part. Motorola and  are registered trademarks of Motorola, Inc. Motorola, Inc. is an Equal Opportunity/Affirmative Action Employer.

**Literature Distribution Centers:**

USA: Motorola Literature Distribution; P.O. Box 20912; Phoenix, Arizona 85036.

EUROPE: Motorola Ltd.; European Literature Centre; 88 Tanners Drive, Blakelands, Milton Keynes, MK14 5BP, England.

JAPAN: Nippon Motorola Ltd.; 4-32-1, Nishi-Gotanda, Shinagawa-ku, Tokyo 141, Japan.

ASIA PACIFIC: Motorola Semiconductors H.K. Ltd.; Silicon Harbour Center, No. 2 Dai King Street, Tai Po Industrial Estate, Tai Po, N.T., Hong Kong.

