

## DM54LS503/DM74LS503 8-Bit Successive Approximation Register (with Expansion Control)

### General Description

The 'LS503 register is basically the same as the 'LS502 except that it has an active LOW Enable ( $\bar{E}$ ) input that is used in cascading two or more packages for longer word lengths. A HIGH signal on  $\bar{E}$ , after a START operation, forces Q7 HIGH and prevents the device from accepting serial data. With the  $\bar{E}$  input of an 'LS503 connected to the  $\overline{CC}$  output of a preceding (more significant) device, the 'LS503 will be inhibited until the preceding device is filled, causing its  $\overline{CC}$  output to go LOW. This LOW signal then enables the 'LS503 to accept the serial data on subsequent clocks. For a description of the starting, shifting and conversion operations, please see the 'LS502 data sheet.

### Features

- Performs serial-to-parallel conversion
- Expansion control for longer words
- Storage and control for successive approximation A to D conversion
- Low power Schottky version of 2503

### Connection Diagram

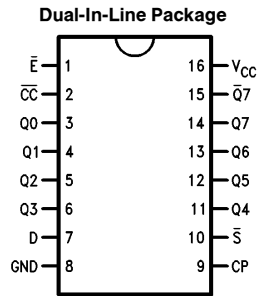

TL/F/10190-1

Order Number DM54LS503J, DM54LS503W,  
DM74LS503WM or DM74LS503N  
See NS Package Number J16A, M16B, N16E or W16A

### Logic Symbol

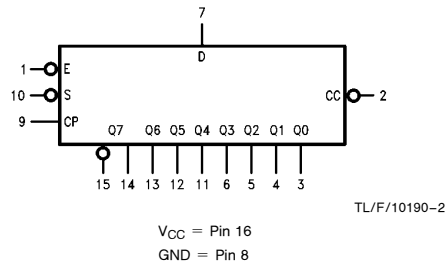

Pin Names	Description
D	Serial Data Input
$\bar{S}$	Start Input (Active LOW)
CP	Clock Pulse Input (Active Rising Edge)
$\bar{E}$	Conversion Enable Input (Active LOW)
$\overline{CC}$	Conversion Complete Output (Active LOW)
Q0-Q7	Parallel Register Outputs
$\bar{Q}7$	Complement of Q7 Output

## Absolute Maximum Ratings (Note)

If Military/Aerospace specified devices are required, please contact the National Semiconductor Sales Office/Distributors for availability and specifications.

Supply Voltage	7V
Input Voltage	7V
Operating Free Air Temperature Range	
DM54LS	−55°C to +125°C
DM74LS	0°C to +70°C
Storage Temperature Range	−65°C to +150°C

Note: The "Absolute Maximum Ratings" are those values beyond which the safety of the device cannot be guaranteed. The device should not be operated at these limits. The parametric values defined in the "Electrical Characteristics" table are not guaranteed at the absolute maximum ratings. The "Recommended Operating Conditions" table will define the conditions for actual device operation.

## Recommended Operating Conditions

Symbol	Parameter	DM54LS503			DM74LS503			Units
		Min	Nom	Max	Min	Nom	Max	
V <sub>CC</sub>	Supply Voltage	4.5	5	5.5	4.75	5	5.25	V
V <sub>IH</sub>	High Level Input Voltage	2			2			V
V <sub>IL</sub>	Low Level Input Voltage			0.7			0.8	V
I <sub>OH</sub>	High Level Output Voltage			−0.4			−0.4	mA
I <sub>OL</sub>	Low Level Output Current			4			8	mA
T <sub>A</sub>	Free Air Operating Temperature	−55		125	0		70	°C
t <sub>s</sub> (H) t <sub>s</sub> (L)	Setup Time HIGH or LOW S̄ to CP	5			16			ns
t <sub>h</sub> (H) t <sub>h</sub> (L)	Hold Time HIGH or LOW S̄ to CP	5			0			ns
t <sub>s</sub> (H) t <sub>s</sub> (L)	Setup Time HIGH or LOW D to CP	5			8			ns
t <sub>h</sub> (H) t <sub>h</sub> (L)	Hold Time HIGH or LOW D to CP	5			10			ns
t <sub>w</sub> (H) t <sub>w</sub> (L)	CP Pulse Width HIGH or LOW	20			46			ns

## Electrical Characteristics Over recommended operating free air temperature range (unless otherwise noted)

Symbol	Parameter	Conditions	Min	Typ (Note 1)	Max	Units
V <sub>I</sub>	Input Clamp Voltage	V <sub>CC</sub> = Min, I <sub>I</sub> = −18 mA			−1.5	V
V <sub>OH</sub>	High Level Output Voltage	V <sub>CC</sub> = Min, I <sub>OH</sub> = Max, V <sub>IL</sub> = Max	DM54 2.5			V
			DM74 2.7			
V <sub>OL</sub>	Low Level Output Voltage	V <sub>CC</sub> = Min, I <sub>OL</sub> = Max, V <sub>IH</sub> = Min	DM54		0.4	V
			DM74		0.5	
		I <sub>OL</sub> = 4 mA, V <sub>CC</sub> = Min	DM74		0.4	
I <sub>I</sub>	Input Current @ Max Input Voltage	V <sub>CC</sub> = Max, V <sub>I</sub> = 7V V <sub>I</sub> = 10V	DM74 DM54		0.1	mA
I <sub>IH</sub>	High Level Input Current	V <sub>CC</sub> = Max, V <sub>I</sub> = 2.7V			20	μA
I <sub>IL</sub>	Low Level Input Current	V <sub>CC</sub> = Max, V <sub>I</sub> = 0.4V			−0.8	mA
I <sub>OS</sub>	Short Circuit Output Current	V <sub>CC</sub> = Max (Note 2)	DM54 DM74	−20 −20	−100 −100	mA
I <sub>CC</sub>	Supply Current	V <sub>CC</sub> = Max			65	mA

Note 1: All typicals are at V<sub>CC</sub> = 5V, T<sub>A</sub> = 25°C.

Note 2: Not more than one output should be shorted at a time, and the duration should not exceed one second.

## Switching Characteristics $V_{CC} = +5.0V, T_A = +25^\circ C$

Symbol	Parameter	DM54LS503		DM74LS503		Units
		$R_L = 2\text{ k}\Omega, C_L = 15\text{ pF}$				
		Min	Max	Min	Max	
$f_{max}$	Maximum Count Frequency	25		15		MHz
$t_{PLH}$ $t_{PHL}$	Propagation Delay CP to Qn or $\overline{CC}$		35 25		35 25	ns
$t_{PLH}$ $t_{PHL}$	Propagation Delay $\overline{E}$ to Q7		20 24		20 24	ns

## Logic Diagram

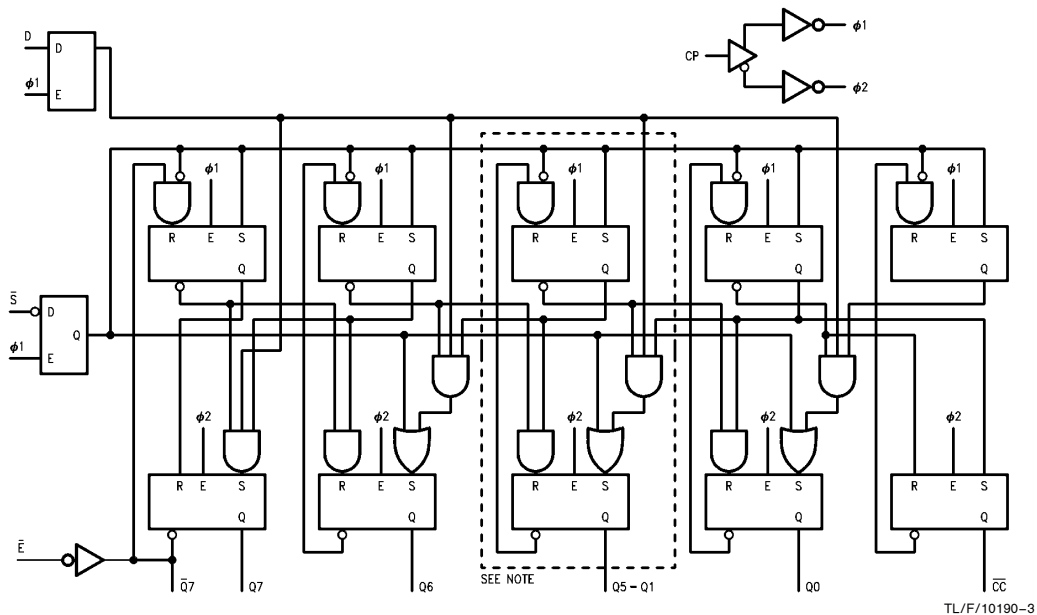

**Note:** Cell logic is repeated for register stages Q5 to Q1.

TL/F/10190-3

## Connection for Longer Word Lengths

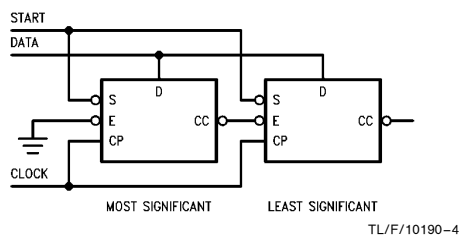

TL/F/10190-4

**Physical Dimensions** inches (millimeters)

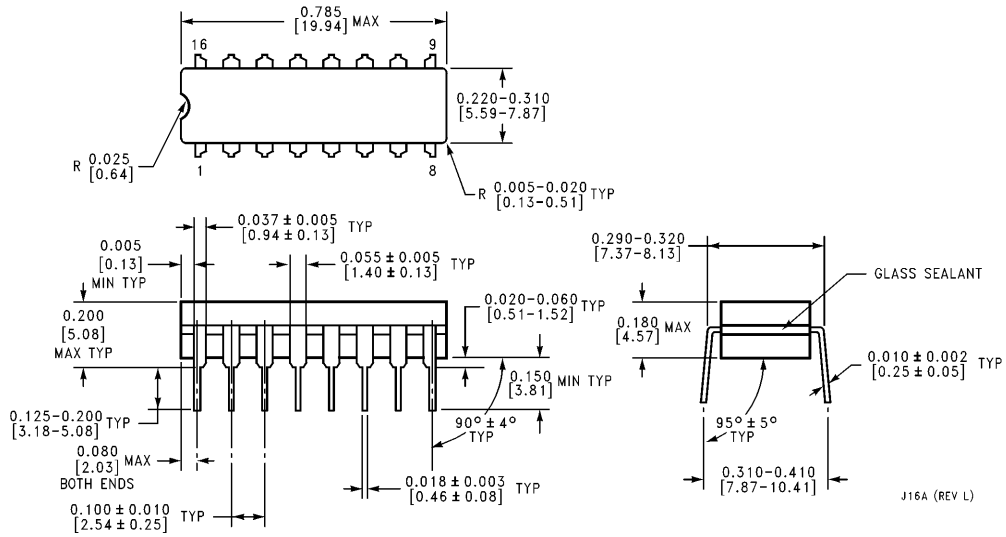

**16-Lead Ceramic Dual-In-Line Package (J)**  
**Order Number DM54LS503J**  
**NS Package Number J16A**

J16A (REV L)

**Physical Dimensions** inches (millimeters) (Continued)

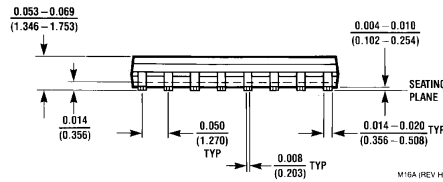
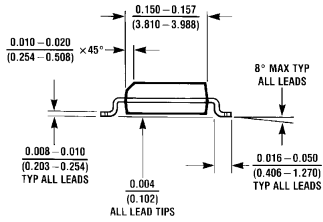
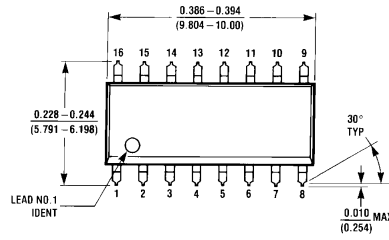

**16-Lead Wide Small Outline Molded Package (M)**  
**Order Number DM74LS03WM**  
**NS Package Number M16B**

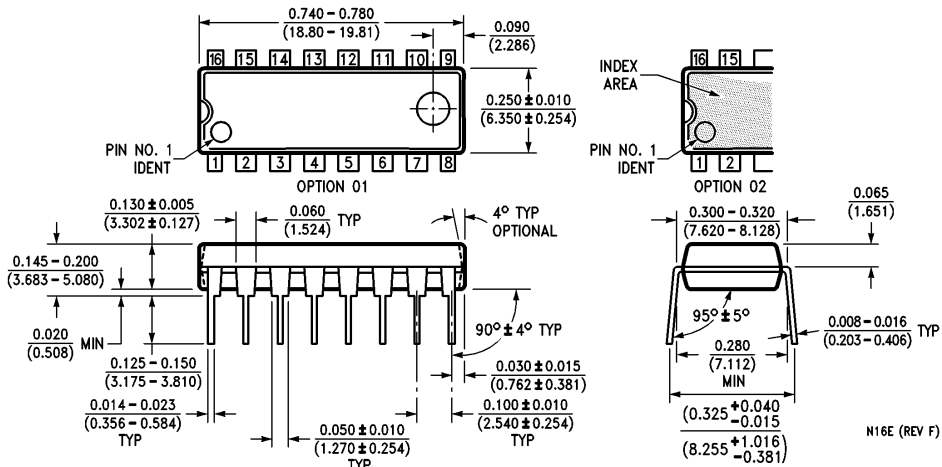

**16-Lead Molded Dual-In-Line Package (N)**  
**Order Number DM74LS03N**  
**NS Package Number N16E**

**DM54LS503/DM74LS503 8-Bit Successive Approximation Register (with Expansion Control)**

**Physical Dimensions** inches (millimeters) (Continued)

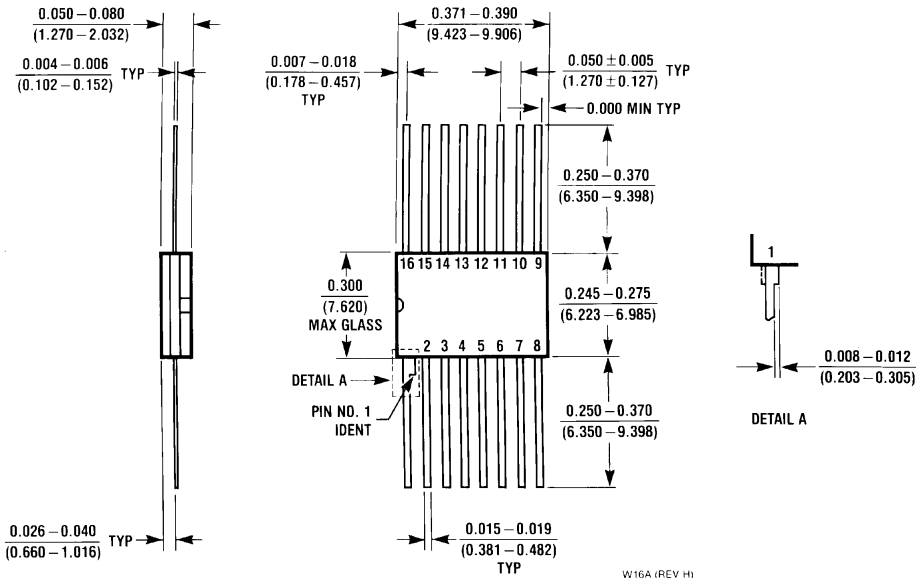

**16-Lead Ceramic Flat Package (W)**  
**Order Number DM54LS503W**  
**NS Package Number W16A**

**LIFE SUPPORT POLICY**

NATIONAL'S PRODUCTS ARE NOT AUTHORIZED FOR USE AS CRITICAL COMPONENTS IN LIFE SUPPORT DEVICES OR SYSTEMS WITHOUT THE EXPRESS WRITTEN APPROVAL OF THE PRESIDENT OF NATIONAL SEMICONDUCTOR CORPORATION. As used herein:

1. Life support devices or systems are devices or systems which, (a) are intended for surgical implant into the body, or (b) support or sustain life, and whose failure to perform, when properly used in accordance with instructions for use provided in the labeling, can be reasonably expected to result in a significant injury to the user.
2. A critical component is any component of a life support device or system whose failure to perform can be reasonably expected to cause the failure of the life support device or system, or to affect its safety or effectiveness.



**National Semiconductor Corporation**  
 1111 West Bardin Road  
 Arlington, TX 76017  
 Tel: 1(800) 272-9959  
 Fax: 1(800) 737-7018

**National Semiconductor Europe**  
 Fax: (+49) 0-180-530 85 86  
 Email: onjwge@tevm2.nsc.com  
 Deutsch Tel: (+49) 0-180-530 85 85  
 English Tel: (+49) 0-180-532 78 32  
 Français Tel: (+49) 0-180-532 93 58  
 Italiano Tel: (+49) 0-180-534 16 80

**National Semiconductor Hong Kong Ltd.**  
 13th Floor, Straight Block,  
 Ocean Centre, 5 Canton Rd.  
 Tsimshatsui, Kowloon  
 Hong Kong  
 Tel: (852) 2737-1600  
 Fax: (852) 2736-9960

**National Semiconductor Japan Ltd.**  
 Tel: 81-043-299-2309  
 Fax: 81-043-299-2408

National does not assume any responsibility for use of any circuitry described, no circuit patent licenses are implied and National reserves the right at any time without notice to change said circuitry and specifications.