

74LVX3L383

10-Bit Low Power Bus-Exchange Switch

General Description

The LVX3L383 provides two sets of high-speed CMOS TTL-compatible bus switches. The low on resistance of the switch allows inputs to be connected to outputs without adding propagation delay or generating additional ground bounce noise. The device operates as a 10-bit bus switch or a 5-bit bus exchanger. The bus exchange (BX) signal provides nibble swapping of the AB and CD pairs of signals. This exchange configuration allows byte swapping of buses in systems. It can also be used as a quad 2-to-1 multiplexer and to create low delay barrel shifters. The bus enable (\overline{BE}) signal turns the switches on.

Features

- 5Ω switch connection between two ports
- Zero propagation delay
- Ultra low power with $0.2\ \mu\text{A}$ typical I_{CC}
- Zero ground bounce in flow-through mode
- Control inputs compatible with TTL level
- Available in SOIC, TSSOP and QSOP (SSOP, 0.15" body width) packages

Logic Diagram

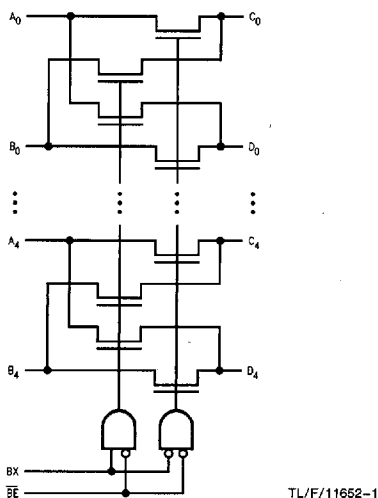

Connection Diagram

Pin Assignment for
SOIC, QSOP and TSSOP

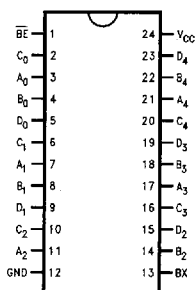

TL/F/11652-2

Pin Names	Description
\overline{BE}	Bus Switch Enable
BX	Bus Exchange
A_0 - A_4 , B_0 - B_4	Buses A, B
C_0 - C_4 , D_0 - D_4	Buses C, D

Truth Table

\overline{BE}	BX	A_0 - A_4	B_0 - B_4	Function
H	X	High-Z State	High-Z State	Disconnect
L	L	C_0 - C_4	D_0 - D_4	Connect
L	H	D_0 - D_4	C_0 - C_4	Exchange

	SOIC JEDEC	QSOP	TSSOP
Order Number	74LVX3L383WM 74LVX3L383WMX	74LVX3L383QSC 74LVX3L383QSCX	74LVX3L383MTC 74LVX3L383MTCX
See NS Package Number	M24B	MQA24	MTC24

Absolute Maximum Ratings (Note 1)

If Military/Aerospace specified devices are required, please contact the National Semiconductor Sales Office/Distributors for availability and specifications.

Supply Voltage (V_{CC})	-0.5V to +7.0V
DC Switch Voltage (V_S)	-0.5V to +7.0V
DC Input Voltage (V_I) (Note 2)	-0.5V to +7.0V
DC Input Diode Current (I_{IN}) with $V_I < 0$	-20 mA
DC Output (I_O) Sink Current	120 mA
Storage Temperature Range (T_{STG})	-65°C to +150°C
Power Dissipation	0.5W

Note 1: The "Absolute Maximum Ratings" are those values beyond which the safety of the device cannot be guaranteed. The device should not be operated at these limits. The parametric values defined in the "Electrical Characteristics" table are not guaranteed at the absolute maximum ratings. The "Recommended Operating Conditions" table will define the conditions for actual device operation.

Note 2: The input and output negative voltage ratings may be exceeded if the input and output diode current ratings are observed.

Recommended Operating Conditions

Supply Voltage (V_{CC})	4.0V to 5.5V
Free Air Operating Temperature (T_A)	-40°C to +85°C

DC Electrical Characteristics

Symbol	Parameter	V_{CC} (V)	74LVX3L383			Units	Conditions
			$T_A = -40^\circ\text{C to } +85^\circ\text{C}$				
			Min	Typ (Note 5)	Max		
V_{IK}	Maximum Clamp Diode Voltage	4.75		-1.2	V	$I_{IN} = -18 \text{ mA}$	
V_{IH}	Minimum High Level Input Voltage	4.75-5.25	2.0		V		
V_{IL}	Maximum Low Level Input Voltage	4.75-5.25		0.8			
I_{IN}	Maximum Input Leakage Current	0		10	μA	$0 \leq V_{IN} \leq 5.25\text{V}$	
		5.25		± 1			
I_{OZ}	Maximum TRI-STATE® I/O Leakage	5.25		± 10	μA	$0 \leq A, B \leq V_{CC}$	
I_{OS}	Short Circuit Current	4.75	100		mA	$V_I(A), V_I(B) = 0\text{V}$, $V_I(B), V_I(A) = 4.75\text{V}$	
R_{ON}	Switch On Resistance (Note 3)	4.75	5	7	Ω	$V_I = 0\text{V}$, $I_{ON} = 30 \text{ mA}$	
			10	15			$V_I = 2.4\text{V}$, $I_{ON} = 15 \text{ mA}$
I_{CC}	Maximum Quiescent Supply Current	5.25	0.2	10	μA	$V_I = V_{CC}$, GND $I_O = 0$	
ΔI_{CC}	Increase in I_{CC} per Input (Note 4)	5.25		2.5	mA	$V_{IN} = 3.15\text{V}$, $I_O = 0$ Per Control Input	

Note 3: Measured by voltage drop between A and B pin at indicated current through the switch. On resistance is determined by the lower of the voltages on the two (A or B) pins.

Note 4: Per TTL driven input ($V_{IN} = 3.15\text{V}$, control inputs only). A and B pins do not contribute to I_{CC} .

Note 5: All typical values are at $V_{CC} = 5.0\text{V}$, $T_A = 25^\circ\text{C}$.

AC Electrical Characteristics: See Section 2 for Test Methodology

Symbol	Parameter	V _{CC} (V)	74LVX3L383			Units
			T _A = -40°C to +85°C C _L = 50 pF			
			Min	Typ (Note 5)	Max	
t _{PLH} t _{PHL}	Data Propagation Delay A _n to B _n or B _n to A _n (Note 6)	4.75		0.25	ns	
t _{PLH} t _{PHL}	Switch Exchange Time BX to A _n or B _n	4.75	1.5	6.5	ns	
t _{PZL} t _{PZH}	Switch Enable Time B \bar{E} to A _n , B _n	4.75	1.5	6.5	ns	
t _{PLZ} t _{PHZ}	Switch Disenable Time B \bar{E} to A _n , B _n	4.75	1.5	5.5	ns	

Note 5: All typical values are at V_{CC} = 5.0V, T_A = 25°C.

Note 6: This parameter is guaranteed by design but not tested. The bus switch contributes no propagation delay other than the RC delay of the On resistance of the switch and the load capacitance. The time constant for the switch and alone is of the order of 0.25 ns for 50 pF load. Since this time constant is much smaller than the rise/fall times of typical driving signals, it adds very little propagation delay to the system. Propagation delay of the bus switch when used in a system is determined by the driving circuit on the driving side of the switch and its interaction with the load on the driven side.

Capacitance (Note)

Symbol	Parameter	Typ	Max	Units	Conditions
C _{IN}	Control Input Capacitance	4	6	pF	V _{CC} = 5.0V
C _{I/O (OFF)}	Input/Output Capacitance	9	13	pF	V _{CC} = 5.0V

Note: Capacitance is characterized but not tested.

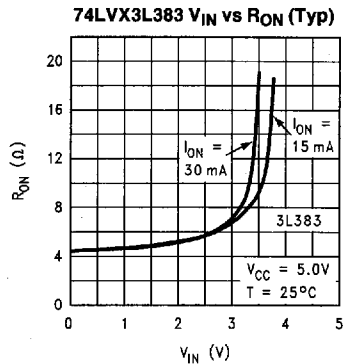

TL/F/11652-4