



78KXX

LINEAR INTEGRATED CIRCUIT

3-TERMINAL 50mA POSITIVE VOLTAGE REGULATOR

DESCRIPTION

The UTC 78KXX family is monolithic fixed voltage regulator integrated circuit. They are suitable for applications that required supply current up to 50mA.

FEATURES

- * Output current up to 50mA
- * Fixed output voltage of 5V, 6V, 8V, 9V, 10V, 12V, 15V and 18V available
- * Thermal overload shutdown protection
- * Short circuit current limiting

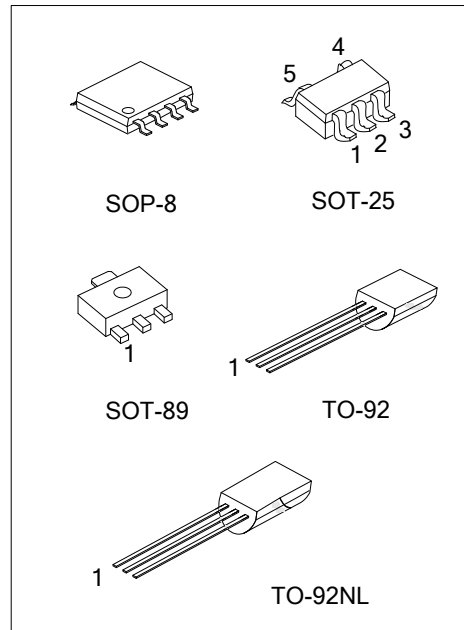

ORDERING INFORMATION

Ordering Number		Package	Pin Assignment								Packing
Lead Free	Halogen Free		1	2	3	4	5	6	7	8	
78KXXL-AB3-R	78KXXG-AB3-R	SOT-89	O	G	I	-	-	-	-	-	Tape Reel
78KXXL-AB3-C-R	78KXXG-AB3-C-R	SOT-89	G	I	O	-	-	-	-	-	Tape Reel
78KXXL-AF5-R	78KXXG-AF5-R	SOT-25	G	I	O	N	N				Tape Reel
78KXXL-S08-R	78KXXG-S08-R	SOP-8	O	G	G	N	N	G	G	I	Tape Reel
78KXXL-T92-B	78KXXG-T92-B	TO-92	O	G	I	-	-	-	-	-	Tape Box
78KXXL-T92-K	78KXXG-T92-K	TO-92	O	G	I	-	-	-	-	-	Bulk
78KXXL-T9N-B	78KXXG-T9N-B	TO-92NL	O	G	I	-	-	-	-	-	Tape Box
78KXXL-T9N-K	78KXXG-T9N-K	TO-92NL	O	G	I	-	-	-	-	-	Bulk

Note: 1. XX: Output Voltage, refer to Marking Information.

2. Pin Assignment: O: Output G: GND I: Input N: No Connection

<p>78KXXG-AB3-C-R</p>	<p>(1) Packing Type (2) Pin Assignment (3) Package Type (4) Green Package (5) Output Voltage Code</p>	<p>(1) B: Tape Box, K: Bulk, R: Tape Reel (2) refer to Pin Assignment (3) AB3: SOT-89, AF5: SOT-25, S08: SOP-8, T92: TO-92, T9N: TO-92NL (4) G: Halogen Free and Lead Free, L: Lead Free (5) XX: refer to Marking Information</p>
-----------------------	---	---

MARKING INFORMATION

PACKAGE	VOLTAGE CODE	MARKING
SOT-89	05:5.0V 06:6.0V 08:8.0V 09:9.0V 10:10V 12:12V 15:15V 18:18V	
SOT-25		
SOP-8		
TO-92		
TO-92NL		

■ ABSOLUTE MAXIMUM RATINGS

PARAMETER		SYMBOL	RATINGS	UNIT
Input Voltage	$V_{OUT}=5\sim 9V$	V_{IN}	30	V
	$V_{OUT}=10\sim 18V$		35	
Output Current		I_{OUT}	50	mA
Power Dissipation	SOT-89	P_D	350	mW
	SOT-25		240	mW
	SOP-8		300	mW
	TO-92/TO-92NL		625	mW
Junction Temperature		T_J	+150	°C
Operating Temperature (Note 2)		T_{OPR}	-40 ~ +125	°C
Storage Temperature		T_{STG}	-55 ~ +150	°C

- Notes: 1. Absolute maximum ratings are those values beyond which the device could be permanently damaged. Absolute maximum ratings are stress ratings only and functional device operation is not implied.
2. It is guarantee by design, not 100% be tested.

■ ELECTRICAL CHARACTERISTICS

For UTC78K05 ($V_{IN}=10V$, $I_{OUT}=10mA$, $0^\circ C < T_J < 150^\circ C$, $C_1=0.33\mu F$, $C_o=0.1\mu F$, unless otherwise specified)

PARAMETER	SYMBOL	TEST CONDITIONS	MIN	TYP	MAX	UNIT
Output Voltage	V_{OUT}	$T_J=25^\circ C$	4.80	5.0	5.20	V
		$7V \leq V_{IN} \leq V_{MAX}$, $I_{OUT}=1mA-50mA$	4.75		5.25	V (note 2)
Load Regulation	ΔV_{OUT}	$T_J=25^\circ C$, $I_{OUT}=1mA-50mA$		15	60	mV
Line regulation	ΔV_{OUT}	$7V \leq V_{IN} \leq 20V$, $T_J=25^\circ C$		8	150	mV
		$8V \leq V_{IN} \leq 20V$, $T_J=25^\circ C$		6	100	mV
Quiescent Current	I_Q	$V_{IN}=10V$, $I_{OUT}=0mA$, $T_J=25^\circ C$		2.0	5.5	mA
Quiescent Current Change	ΔI_Q	$8V \leq V_{IN} \leq 20V$			1.5	mA
		$1mA \leq V_{IN} \leq 50mA$			0.1	mA
Output Noise Voltage	eN	$10Hz \leq f \leq 100kHz$		40		μV
Temperature coefficient of V_{OUT}	$\Delta V_O/\Delta T$	$I_{OUT}=5mA$		1.0		mV/°C
Ripple Rejection	RR	$8V \leq V_{IN} \leq 20V$, $f=120Hz$, $T_J=25^\circ C$		60		dB
Dropout Voltage	V_D	$T_J=25^\circ C$		1.7		V

For UTC78K06 ($V_{IN}=12V$, $I_{OUT}=10mA$, $0^\circ C < T_J < 150^\circ C$, $C_1=0.33\mu F$, $C_o=0.1\mu F$, unless otherwise specified)

PARAMETER	SYMBOL	TEST CONDITIONS	MIN	TYP	MAX	UNIT
Output Voltage	V_{OUT}	$T_J=25^\circ C$	5.76	6.0	6.24	V
		$8.5V \leq V_{IN} \leq V_{MAX}$, $I_{OUT}=1mA-50mA$	5.70		6.30	V (note 2)
Load Regulation	ΔV_{OUT}	$T_J=25^\circ C$, $I_{OUT}=1mA-50mA$		16	80	mV
Line regulation	ΔV_{OUT}	$8.5V \leq V_{IN} \leq 20V$, $T_J=25^\circ C$		10	175	mV
		$9V \leq V_{IN} \leq 20V$, $T_J=25^\circ C$		8	125	mV
Quiescent Current	I_Q	$V_{IN}=12V$, $I_{OUT}=0mA$, $T_J=25^\circ C$		2.0	5.5	mA
Quiescent Current Change	ΔI_Q	$9V \leq V_{IN} \leq 20V$			1.5	mA
		$1mA \leq V_{IN} \leq 50mA$			0.1	mA
Output Noise Voltage	eN	$10Hz \leq f \leq 100kHz$		49		μV
Temperature coefficient of V_{OUT}	$\Delta V_O/\Delta T$	$I_{OUT}=5mA$		1.3		mV/°C
Ripple Rejection	RR	$10V \leq V_{IN} \leq 20V$, $f=120Hz$, $T_J=25^\circ C$		56		dB
Dropout Voltage	V_D	$T_J=25^\circ C$		1.7		V

■ ELECTRICAL CHARACTERISTICS (Cont.)

For UTC78K08 ($V_{IN}=14V$, $I_{OUT}=10mA$, $0^{\circ}C < T_J < 150^{\circ}C$, $C_1=0.33\mu F$, $C_o=0.1\mu F$, unless otherwise specified)

PARAMETER	SYMBOL	TEST CONDITIONS	MIN	TYP	MAX	UNIT
Output Voltage	V_{OUT}	$T_J=25^{\circ}C$	7.68	8.0	8.32	V
		$10.5V \leq V_{IN} \leq V_{MAX}$, $I_{OUT}=1mA-50mA$	7.60		8.40	V(note 2)
		$T_J=25^{\circ}C$, $I_{OUT}=1mA-50mA$		10	40	mV
Line regulation	ΔV_{OUT}	$10.5V \leq V_{IN} \leq 23V$, $T_J=25^{\circ}C$		12	175	mV
		$11V \leq V_{IN} \leq 23V$, $T_J=25^{\circ}C$		10	125	mV
Quiescent Current	I_Q	$V_{IN}=14V$, $I_{OUT}=0mA$, $T_J=25^{\circ}C$		2.0	5.5	mA
Quiescent Current Change	ΔI_Q	$11V \leq V_{IN} \leq 23V$			1.5	mA
		$1mA \leq V_{IN} \leq 50mA$			0.1	mA
Output Noise Voltage	eN	$10Hz \leq f \leq 100kHz$		49		μV
Temperature coefficient of V_o	$\Delta V_o/\Delta T$	$I_{OUT}=5mA$		1.5		$mV/^{\circ}C$
Ripple Rejection	RR	$11V \leq V_{IN} \leq 23V$, $f=120Hz$, $T_J=25^{\circ}C$		52		dB
Dropout Voltage	V_D	$T_J=25^{\circ}C$		1.7		V

For UTC78K09 ($V_{IN}=15V$, $I_{OUT}=10mA$, $0^{\circ}C < T_J < 150^{\circ}C$, $C_1=0.33\mu F$, $C_o=0.1\mu F$, unless otherwise specified)

PARAMETER	SYMBOL	TEST CONDITIONS	MIN	TYP	MAX	UNIT
Output Voltage	V_{OUT}	$T_J=25^{\circ}C$	8.64	9.0	9.36	V
		$11.5V \leq V_{IN} \leq V_{MAX}$, $I_{OUT}=1mA-50mA$	8.55		9.45	V(note 2)
		$T_J=25^{\circ}C$, $I_{OUT}=1mA-50mA$		10	40	mV
Line regulation	ΔV_{OUT}	$11.5V \leq V_{IN} \leq 24V$, $T_J=25^{\circ}C$		15	200	mV
		$13V \leq V_{IN} \leq 24V$, $T_J=25^{\circ}C$		10	150	mV
Quiescent Current	I_Q	$V_{IN}=15V$, $I_{OUT}=0mA$, $T_J=25^{\circ}C$		2.0	6.0	mA
Quiescent Current Change	ΔI_Q	$13V \leq V_{IN} \leq 24V$			1.5	mA
		$1mA \leq V_{IN} \leq 50mA$			0.1	mA
Output Noise Voltage	eN	$10Hz \leq f \leq 100kHz$		70		μV
Temperature coefficient of V_{OUT}	$\Delta V_o/\Delta T$	$I_{OUT}=5mA$		1.6		$mV/^{\circ}C$
Ripple Rejection	RR	$12V \leq V_{IN} \leq 24V$, $f=120Hz$, $T_J=25^{\circ}C$		46		dB
Dropout Voltage	V_D	$T_J=25^{\circ}C$		1.7		V

For UTC78K10 ($V_{IN}=16V$, $I_{OUT}=10mA$, $0^{\circ}C < T_J < 150^{\circ}C$, $C_1=0.33\mu F$, $C_o=0.1\mu F$, unless otherwise specified)

PARAMETER	SYMBOL	TEST CONDITIONS	MIN	TYP	MAX	UNIT
Output Voltage	V_{OUT}	$T_J=25^{\circ}C$	9.6	10.0	10.4	V
		$12.5V \leq V_{IN} \leq V_{MAX}$, $I_{OUT}=1mA-50mA$	9.5		10.5	V(note 2)
		$T_J=25^{\circ}C$, $I_{OUT}=1mA-50mA$		10	45	mV
Line regulation	ΔV_{OUT}	$12.5V \leq V_{IN} \leq 25V$, $T_J=25^{\circ}C$		25	200	mV
		$14V \leq V_{IN} \leq 25V$, $T_J=25^{\circ}C$		20	170	mV
Quiescent Current	I_Q	$V_{IN}=17V$, $I_{OUT}=0mA$, $T_J=25^{\circ}C$		2.0	6.0	mA
Quiescent Current Change	ΔI_Q	$12.5V \leq V_{IN} \leq 25V$			1.5	mA
		$1mA \leq V_{IN} \leq 50mA$			0.1	mA
Output Noise Voltage	eN	$10Hz \leq f \leq 100kHz$		74		μV
Temperature coefficient of V_{OUT}	$\Delta V_o/\Delta T$	$I_{OUT}=5mA$		1.7		$mV/^{\circ}C$
Ripple Rejection	RR	$15V \leq V_{IN} \leq 25V$, $f=120Hz$, $T_J=25^{\circ}C$		45		dB
Dropout Voltage	V_D	$T_J=25^{\circ}C$		1.7		V

■ ELECTRICAL CHARACTERISTICS (Cont.)

For UTC78K12 ($V_{IN}=19V$, $I_{OUT}=10mA$, $0^{\circ}C < T_J < 150^{\circ}C$, $C_1=0.33\mu F$, $C_o=0.1\mu F$, unless otherwise specified)

PARAMETER	SYMBOL	TEST CONDITIONS	MIN	TYP	MAX	UNIT
Output Voltage	V_{OUT}	$T_J=25^{\circ}C$	11.52	12.0	12.48	V
		$14.5V \leq V_{IN} \leq V_{MAX}$, $I_{OUT}=1mA-50mA$	11.40		12.60	V(note 2)
		$T_J=25^{\circ}C$, $I_{OUT}=1mA-50mA$		12	50	mV
Line regulation	ΔV_{OUT}	$14.5V \leq V_{IN} \leq 27V$, $T_J=25^{\circ}C$		25	300	mV
		$16V \leq V_{IN} \leq 27V$, $T_J=25^{\circ}C$		20	250	mV
Quiescent Current	I_Q	$V_{IN}=19V$, $I_{OUT}=0mA$, $T_J=25^{\circ}C$		2.0	6.5	mA
Quiescent Current Change	ΔI_Q	$16V \leq V_{IN} \leq 27V$			1.5	mA
		$1mA \leq V_{IN} \leq 50mA$			0.1	mA
Output Noise Voltage	eN	$10Hz \leq f \leq 100kHz$		80		μV
Temperature coefficient of V_{OUT}	$\Delta V_O/\Delta T$	$I_{OUT}=5mA$		1.8		$mV/^{\circ}C$
Ripple Rejection	RR	$15V \leq V_{IN} \leq 25V$, $f=120Hz$, $T_J=25^{\circ}C$		45		dB
Dropout Voltage	V_D	$T_J=25^{\circ}C$		1.7		V

For UTC78K15 ($V_{IN}=23V$, $I_{OUT}=10mA$, $0^{\circ}C < T_J < 150^{\circ}C$, $C_1=0.33\mu F$, $C_o=0.1\mu F$, unless otherwise specified)

PARAMETER	SYMBOL	TEST CONDITIONS	MIN	TYP	MAX	UNIT
Output Voltage	V_{OUT}	$T_J=25^{\circ}C$	14.40	15.0	15.60	V
		$17.5V \leq V_{IN} \leq V_{MAX}$, $I_{OUT}=1mA-50mA$	14.25		15.75	V(note 2)
		$T_J=25^{\circ}C$, $I_{OUT}=1mA-50mA$		15	75	mV
Line Regulation	ΔV_{OUT}	$17.5V \leq V_{IN} \leq 30V$, $T_J=25^{\circ}C$		25	150	mV
		$20V \leq V_{IN} \leq 30V$, $T_J=25^{\circ}C$		15	75	mV
Quiescent Current	I_Q	$V_{IN}=23V$, $I_{OUT}=0mA$, $T_J=25^{\circ}C$		2.2	6.5	mA
Quiescent Current Change	ΔI_Q	$20V \leq V_{IN} \leq 30V$			1.5	mA
		$1mA \leq V_{IN} \leq 50mA$			0.1	mA
Output Noise Voltage	eN	$10Hz \leq f \leq 100kHz$		90		μV
Temperature Coefficient of V_{OUT}	$\Delta V_O/\Delta T$	$I_{OUT}=5mA$		2.0		$mV/^{\circ}C$
Ripple Rejection	RR	$18.5V \leq V_{IN} \leq 28.5V$, $f=120Hz$, $T_J=25^{\circ}C$		45		dB
Dropout Voltage	V_D	$T_J=25^{\circ}C$		1.7		V

For UTC78K18 ($V_{IN}=27V$, $I_{OUT}=10mA$, $0^{\circ}C < T_J < 150^{\circ}C$, $C_1=0.33\mu F$, $C_o=0.1\mu F$, unless otherwise specified)

PARAMETER	SYMBOL	TEST CONDITIONS	MIN	TYP	MAX	UNIT
Output Voltage	V_{OUT}	$T_J=25^{\circ}C$	17.28	18.0	18.72	V
		$21V \leq V_{IN} \leq V_{MAX}$, $I_{OUT}=1mA-50mA$	17.46		18.54	V(note 2)
		$T_J=25^{\circ}C$, $I_{OUT}=1mA-50mA$		20	90	mV
Line Regulation	ΔV_{OUT}	$21V \leq V_{IN} \leq 33V$, $T_J=25^{\circ}C$		45	300	mV
		$22V \leq V_{IN} \leq 33V$, $T_J=25^{\circ}C$		35	250	mV
Quiescent Current	I_Q	$V_{IN}=27V$, $I_{OUT}=0mA$, $T_J=25^{\circ}C$		2.2	6.5	mA
Quiescent Current Change	ΔI_Q	$21V \leq V_{IN} \leq 33V$			1.5	mA
		$1mA \leq V_{IN} \leq 50mA$			0.1	mA
Output Noise Voltage	eN	$10Hz \leq f \leq 100kHz$		150		μV
Temperature Coefficient of V_{OUT}	$\Delta V_O/\Delta T$	$I_{OUT}=5mA$		2.2		$mV/^{\circ}C$
Ripple Rejection	RR	$23V \leq V_{IN} \leq 33V$, $f=120Hz$, $T_J=25^{\circ}C$		45		dB
Dropout Voltage	V_D	$T_J=25^{\circ}C$		1.7		V

Note 1. The Maximum steady state usable output current is dependent on input voltage, heat sinking, lead length of the package and copper pattern of PCB.

2. Power dissipation $< 0.5W$

■ APPLICATION CIRCUIT

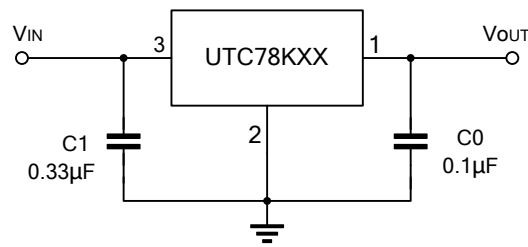

- Notes:
1. To specify an output voltage, substitute voltage value for "XX".
 2. Bypass capacitors are recommended for optimum stability and transient response and should be located as close as possible to the regulators.

■ TEST CIRCUIT

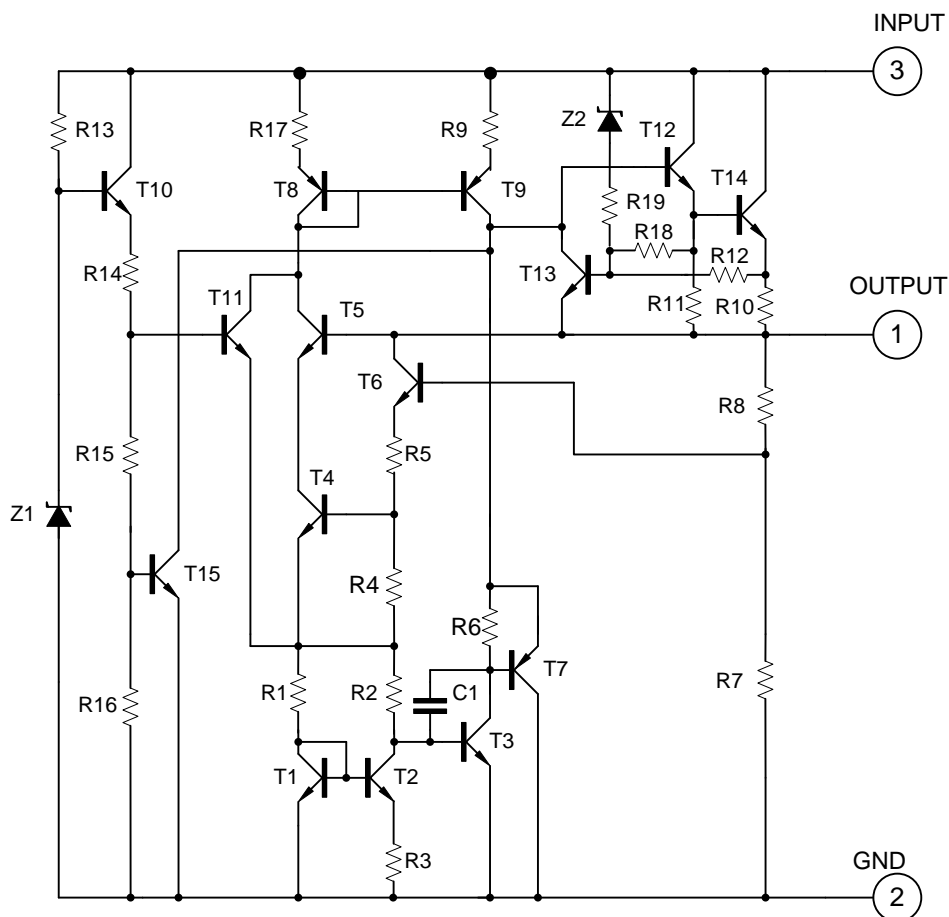

UTC assumes no responsibility for equipment failures that result from using products at values that exceed, even momentarily, rated values (such as maximum ratings, operating condition ranges, or other parameters) listed in products specifications of any and all UTC products described or contained herein. UTC products are not designed for use in life support appliances, devices or systems where malfunction of these products can be reasonably expected to result in personal injury. Reproduction in whole or in part is prohibited without the prior written consent of the copyright owner. UTC reserves the right to make changes to information published in this document, including without limitation specifications and product descriptions, at any time and without notice. This document supersedes and replaces all information supplied prior to the publication hereof.