

## Power Integrated Module (PIM)

### ■ Features

- PT-Technology
- Solderable Package
- High Short Circuit Withstand-Capability
- Small Temperature Dependence of the Turn-Off Switching Loss
- Low Losses And Soft Switching

### ■ Equivalent Circuit

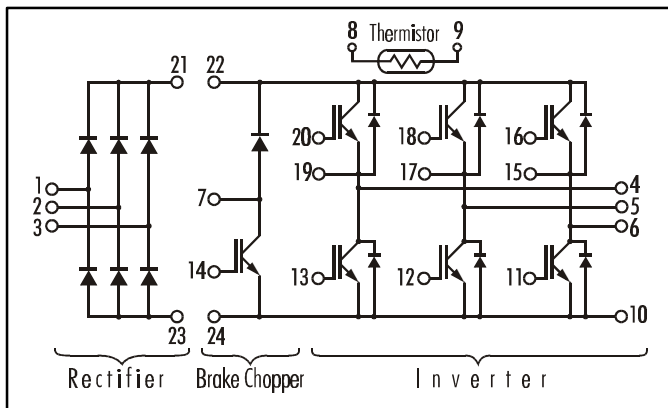

### ■ Outline Drawing

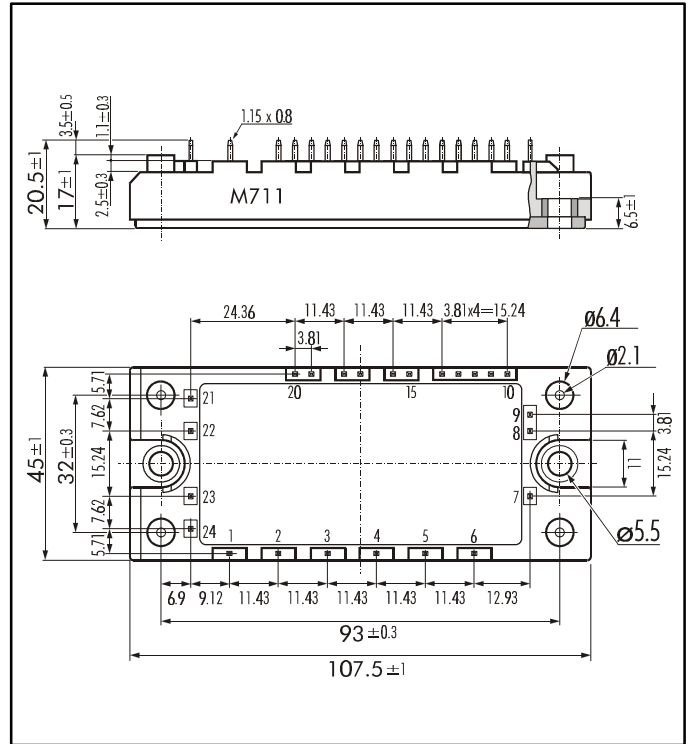

### ■ Absolute Maximum Ratings ( $T_c=25^\circ\text{C}$ )

	Items	Symbols	Test Conditions	Ratings	Units	
Inverter	Collector-Emitter Voltage	$V_{CES}$		600	V	
	Gate -Emitter Voltage	$V_{GES}$		$\pm 20$		
	Collector Current	$I_C$		Continuous	50	A
		$I_{C PULSE}$		1ms	100	
		$-I_C PULSE$			50	
Collector Power Dissipation	$P_C$		1 device	200	W	
Rectifier	Repetitive Peak Reverse Voltage	$V_{RRM}$		800	V	
	Average Output Current	$I_O$	50Hz/60Hz sinus wave	50	A	
	Surge Current (Non Repetitive)	$I_{FSM}$	$T_j=150^\circ\text{C}$ , 10 ms, sinus wave	350	$\text{A}^2\text{s}$	
	$I^2t$ (Non Repetitive)			613		
Brake Chopper	Collector-Emitter Voltage	$V_{CES}$		600	V	
	Gate -Emitter Voltage	$V_{GES}$		$\pm 20$		
	Collector Current	$I_C$		Continuous	30	A
		$I_{C PULSE}$		1ms	60	
	Collector Power Dissipation	$P_C$		1 device	120	W
Repetitive Peak Reverse Voltage	$V_{RRM}$			600	V	
Operating Junction Temperature	$T_j$			+150	$^\circ\text{C}$	
Storage Temperature	$T_{Stg}$			-40 ~ +125		
Isolation Voltage	$V_{ISO}$		A.C. 1min.	2500	V	
Mounting Screw Torque*				3.5	Nm	

Note: \*:Recommendable Value; 2.5 ~ 3.5 Nm (M5)

## ■ Electrical Characteristics ( $T_j=25^\circ\text{C}$ )

Items		Symbols	Test Conditions	Min.	Typ.	Max.	Units		
Inverter	IGBT	Zero Gate Voltage Collector Current	$I_{CES}$	$V_{GE}=0V$ $V_{CE}=600V$			1.0	mA	
		Gate-Emitter Leakage Current	$I_{GES}$	$V_{CE}=0V$ $V_{GE}=\pm 20V$			200	nA	
		Gate-Emitter Threshold Voltage	$V_{GE(th)}$	$V_{GE}=20V$ $I_C=50mA$	5.5	7.8	8.5	V	
		Collector-Emitter Saturation Voltage	$V_{CE(sat)}$	$V_{GE}=15V$ $I_C = 50A$		1.8	2.40		
		Input Capacitance	$C_{ies}$	$f=1MHz$ , $V_{GE}=0V$ , $V_{CE}=10V$		5000		pF	
	Turn-on Time	$t_{on}$	Inductive Load			0.45	1.2	$\mu\text{s}$	
		$t_{r,x}$			$V_{CC} = 300V$ $I_C = 50A$ $V_{GE} = \pm 15V$ $R_G = 51\Omega$		0.25		0.6
		$t_{r,i}$					0.40		1.0
		Turn-off Time			$t_{off}$		0.05		0.35
					$t_f$				
FRD	Diode Forward On-Voltage	$V_F$	$I_F=50A$	Chip		1.75	V		
	Reverse Recovery Time	$t_{rr}$	$I_F=50A$	Terminal		1.9	2.6		
Rectifier	Forward Voltage	$V_{FM}$	$I_F=50A$	Chip		1.1	V		
	Reverse Current	$I_{RRM}$	$V_R=800V$	Terminal		1.2		1.5	
Brake Chopper	Zero Gate Voltage Collector Current	$I_{CES}$	$V_{GE}=0V$ $V_{CE}=600V$			1.0	mA		
	Gate-Emitter Leakage Current	$I_{GES}$	$V_{CE}=0V$ $V_{GE}=\pm 20V$			200	nA		
	Collector-Emitter Saturation Voltage	$V_{CE(sat)}$	Inductive Load	$V_{GE}=15V$	Chip		1.80		
				$I_C=30A$	Terminal		1.95		2.4
	Turn-on Time	$t_{on}$	Inductive Load	$V_{CC} = 300V$ $I_C = 30A$ $V_{GE} = \pm 15V$ $R_G = 82\Omega$		0.45	1.2		
		$t_{r,x}$				0.25	0.6		
		$t_{r,i}$				0.40	1.0		
Turn-off Time	$t_{off}$			0.05	0.35				
	$t_f$								
Reverse Current	$I_{RRM}$	$V_R=600V$			1.0	mA			
NTC	Resistance	R	$T= 25^\circ\text{C}$		5000		$\Omega$		
			$T=100^\circ\text{C}$	465	495	520			
B Value	B	$T=25 / 50^\circ\text{C}$		3305	3375	3450	K		

## ■ Thermal Characteristics

Items	Symbols	Test Conditions	Min.	Typ.	Max.	Units
Thermal Resistance (1 device)	$R_{th(j-c)}$	Inverter IGBT			0.63	$^\circ\text{C/W}$
		Inverter FRD			1.33	
		Brake IGBT			1.04	
		Rectifier Diode			2.42	
Contact Thermal Resistance	$R_{th(c-f)}$	With Thermal Compound		0.05		

