

# UTC81XX

# LINEAR INTEGRATED CIRCUIT

## POWER RESET IC

### DESCRIPTION

The function of UTC 81XX is to accurately reset system after detecting the supply voltage at the time of switching power on and instantaneous power off in various CPU and other logic systems. Further, this IC, with its super low consumption current and high precision voltage detection capacity, is most suited as a voltage check circuit for a number of products which use batteries.

### FEATURES

- \*High precision voltage detection. ( $V_s \pm 3\%$  max)
- \*low current consumption.  
( $I_{CCH} = 15\mu A$  typ.  $I_{CCL} = 10\mu A$  typ.)
- \*Low operating threshold voltage (0.65V typ.)
- \*Hysteresis voltage is provided as a detect voltage.  
(50mV typ.)
- \*Large output current at the time ON (15mA typ.)
- \*The detect voltage can be selected at your discretion at 0.1V step within the range of 1.9V to 4.6V by the following stipulation method.  
UTC 81XX (XX : detected voltage value)

### APPLICATIONS

- \*Reset circuits for microcomputers, CPU and MPU.
- \*Reset circuit for logic circuitry.
- \*Battery voltage check circuit.
- \*Circuit for changing over to backup battery.
- \*Level detecting circuit.

### BLOCK DIAGRAM

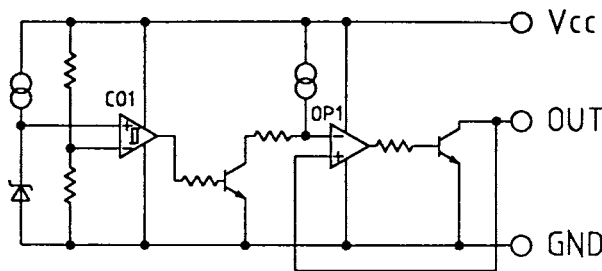

The Pin2 this product is SUB, so connect the pin to Ground.

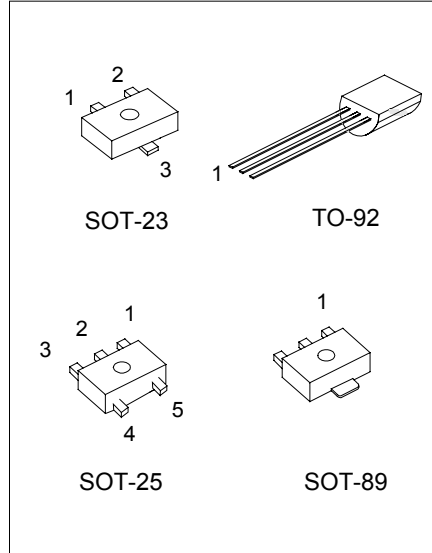

SOT-23 : SEE PAGE 2  
SOT-25 : SEE PAGE 2  
TO-92 1: VOUT; 2: VCC; 3: GND  
SOT-89 1: VCC 2: GND 3: VOUT

# UTC81XX LINEAR INTEGRATED CIRCUIT

## MARKING INFORMATION

PACKAGE	PIN CODE	PIN 1	PIN 2	PIN 3	PIN4	PIN 5	MARKING
SOT-23	2	Vcc	VOUT	GND	--	--	
	3	VOUT	GND	Vcc	--	--	
	5	GND	VOUT	Vcc	--	--	
SOT-25	A	NC	NC	GND	VOUT	Vcc	
	B	VOUT	Vcc	GND	NC	NC	
TO-92	D	Vcc	GND	Vout	--	--	
	E	Vout	Vin	GND			

## ABSOLUTE MAXIMUM RATINGS

PARAMETER	SYMBOL	VALUE	UNIT
Storage temperature	TSTG	-40~+125	°C
Operating temperature	TOPR	-20~+75	°C
Power supply voltage	Vcc	-0.3~+10	V

## ELECTRICAL CHARACTERISTICS (Ta=25°C, The unit of resistance is Ω unless otherwise indicated.)

PARAMETER	SYMBOL	(*1)	TEST CONDITIONS	MIN	TYP	MAX	UNIT	
Detection Voltage	Vs	1	RL=470Ω, Vcc=H->L, Vo=Vcc	UTC 8150	4.850	5.000	5.150	V
				UTC 8146	4.462	4.600	4.738	
				UTC 8145	4.365	4.500	4.635	
				UTC 8144	4.268	4.400	4.532	
				UTC 8143	4.171	4.300	4.429	
				UTC 8142	4.074	4.200	4.326	
				UTC 8141	3.977	4.100	4.223	
				UTC 8140	3.880	4.000	4.120	
				UTC 8139	3.783	3.900	4.017	
				UTC 8138	3.686	3.800	3.914	
				UTC 8137	3.589	3.700	3.811	
				UTC 8136	3.492	3.600	3.708	

**UTC** UNISONIC TECHNOLOGIES CO., LTD.

2

QW-R119-001,1

# UTC81XX LINEAR INTEGRATED CIRCUIT

PARAMETER	SYMBOL	(*1)	TEST CONDITIONS	MIN	TYP	MAX	UNIT
			UTC 8135	3.395	3.500	3.605	
			UTC 8134	3.298	3.400	3.502	
			UTC 8133	3.201	3.300	3.399	
			UTC 8132	3.104	3.200	3.296	
			UTC 8131	3.007	3.100	3.193	
			UTC 8130	2.910	3.000	3.090	
			UTC 8129	2.813	2.900	2.987	
			UTC 8128	2.716	2.800	2.884	
			UTC 8127	2.619	2.700	2.781	
			UTC 8126	2.522	2.600	2.678	
			UTC 8125	2.425	2.500	2.575	
			UTC 8124	2.328	2.400	2.472	
			UTC 8123	2.231	2.300	2.369	
			UTC 8122	2.134	2.200	2.266	
			UTC 8121	2.037	2.100	2.163	
			UTC 8120	1.940	2.000	2.060	
			UTC 8119	1.843	1.900	1.957	
			UTC 8118	1.746	1.800	1.854	
Hysteresis Voltage	$\Delta V_s$	1	RL=470 $\Omega$ , Vcc=L->H->L, Vo=Vcc	30	50	100	mV
Detection Voltage Temperature Coefficient	Vs/ $\Delta T$	1	RL=470 $\Omega$ , Ta=-20~+75°C Vo=Vcc		$\pm 0.01$		%/°C
Low Level Output Voltage	VOL	1	Vcc=Vs min.-0.05V, RL=470 $\Omega$ , Vo=Vcc		0.2	0.4	V
Output Leakage Current	IOH	1	Vcc=10V, Vo=Vcc			$\pm 0.1$	$\mu A$
Circuit Current at ON Time	ICCL	1	Vcc=Vs min.-0.05V, RL= $\infty$ , Vo=Vcc		3	5	$\mu A$
Circuit Current at OFF Time	ICCH	1	Vcc=Vs typ./0.85, RL= $\infty$ , Vo=Vcc		3	5	$\mu A$
"H" Transmission Delay Time	TpLH (*2)	2	CL=100pF, RL=4.7k $\Omega$		20	60	$\mu S$
"L" Transmission Delay Time	TpHL (*3)	2	CL=100pF, RL=4.7k $\Omega$		20	60	$\mu S$
Operating Threshold Voltage	VOPL	1	RL=4.7k $\Omega$ , VOL $\leq$ 0.4V		0.65	0.85	V
Output current at ON Time 1	IO1	1	RL=0, Vcc=Vs min.-0.05V, Vo=0.4V	5			mA
Output current at ON Time 2	IO2	1	Ta=-20~+75°C RL=0, Vcc=Vs min.-0.15V Vo=0.4V	3			mA

Note:

(\*1) MEASUREMENT CIRCUIT

(\*2) TpLH: Vcc=(Vs Typ. -0.4V) -> (Vs Typ. +0.4V)

(\*3) TpHL: Vcc=(Vs Typ. +0.4V) -> (Vs Typ. -0.4V)

# UTC 81XX LINEAR INTEGRATED CIRCUIT

## MEASURING CIRCUITS

1)

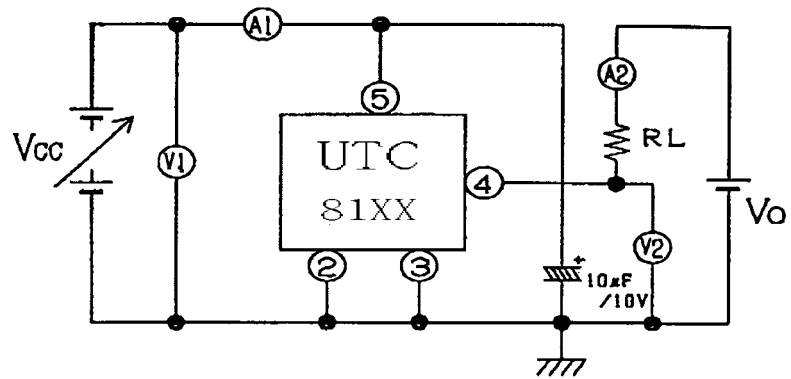

2)

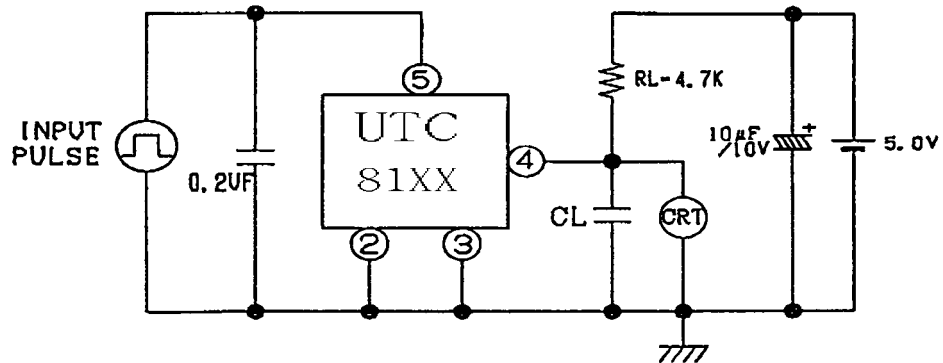

NOTE:

- 1.) A: DC AMMETER    V: DC VOLTMETER    CRT: OSCILLOSCOPE  
 2.) INPUT PULSE

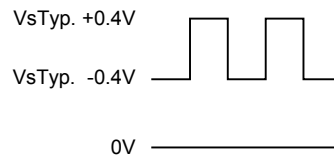

# UTC81XX      LINEAR INTEGRATED CIRCUIT

---

UTC assumes no responsibility for equipment failures that result from using products at values that exceed, even momentarily, rated values (such as maximum ratings, operating condition ranges, or other parameters) listed in products specifications of any and all UTC products described or contained herein. UTC products are not designed for use in life support appliances, devices or systems where malfunction of these products can be reasonably expected to result in personal injury. Reproduction in whole or in part is prohibited without the prior written consent of the copyright owner. The information presented in this document does not form part of any quotation or contract, is believed to be accurate and reliable and may be changed without notice.