

# PCA82C251

## CAN transceiver for 24 V systems

Rev. 04 — 25 August 2011

Product data sheet

### 1. General description

The PCA82C251 is the interface between a CAN protocol controller and the physical bus. The device provides differential transmit capability to the bus and differential receive capability to the CAN controller.

### 2. Features and benefits

- Fully compatible with the "ISO 11898-24 V" standard
- Slope control to reduce Radio Frequency Interference (RFI)
- Thermally protected
- Short-circuit proof to battery and ground in 24 V powered systems
- Low-current Standby mode
- An unpowered node does not disturb the bus lines
- At least 110 nodes can be connected
- High speed (up to 1 MBd)
- High immunity against electromagnetic interference.

### 3. Applications

- High-speed applications (up to 1 MBd) in trucks and busses.

### 4. Quick reference data

Table 1. Quick reference data

Symbol	Parameter	Conditions	Min	Max	Unit
$V_{CC}$	supply voltage		4.5	5.5	V
$I_{CC}$	supply current	Standby mode	-	275	$\mu$ A
$1/t_{bit}$	maximum transmission speed	non-return-to-zero	1	-	MBd
$V_{CAN}$	CANH, CANL input/output voltage		-36	+36	V
$V_{diff}$	differential bus voltage		1.5	3.0	V
$t_{PD}$	propagation delay	High-speed mode	-	50	ns
$T_{amb}$	ambient temperature		-40	+125	$^{\circ}$ C



## 5. Ordering information

Table 2. Ordering information

Type number	Package		Version
	Name	Description	
PCA82C251T	SO8	plastic small outline package; 8 leads; body width 3.9 mm	SOT96-1

## 6. Block diagram

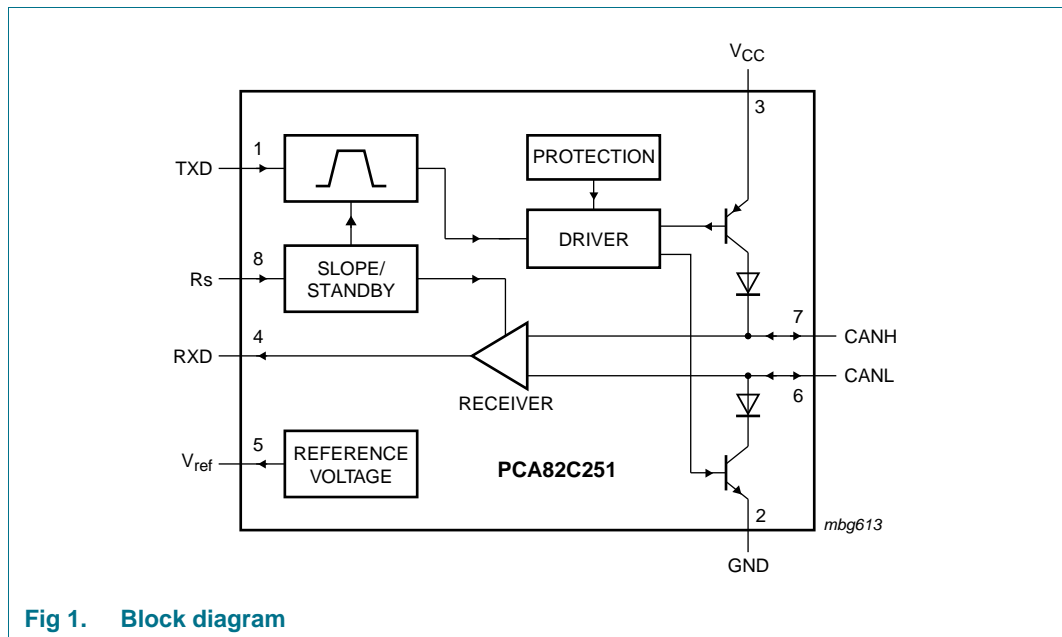

Fig 1. Block diagram

## 7. Pinning information

### 7.1 Pinning

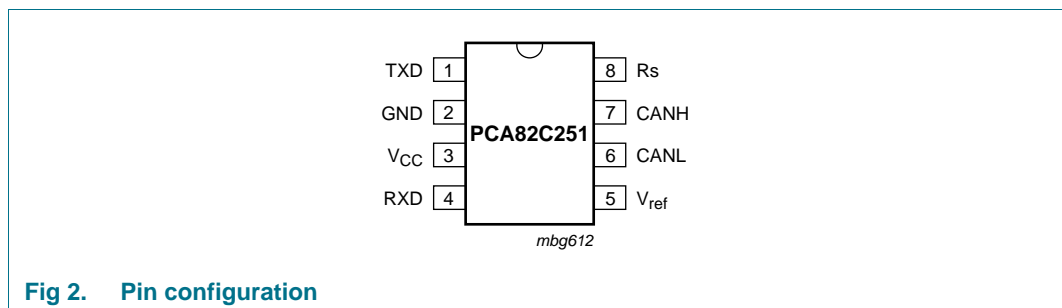

Fig 2. Pin configuration

## 7.2 Pin description

Table 3. Pin description

Symbol	Pin	Description
TXD	1	transmit data input
GND	2	ground
V <sub>CC</sub>	3	supply voltage
RXD	4	receive data output
V <sub>ref</sub>	5	reference voltage output
CANL	6	LOW-level CAN voltage input/output
CANH	7	HIGH-level CAN voltage input/output
Rs	8	slope resistor input

## 8. Functional description

The PCA82C251 is the interface between a CAN protocol controller and the physical bus. It is primarily intended for applications up to 1 MBd in trucks and buses. The device provides differential transmit capability to the bus and differential receive capability to the CAN controller. It is fully compatible with the "ISO 11898-24 V" standard.

A current-limiting circuit protects the transmitter output stage against short-circuits to positive and negative battery voltage. Although power dissipation will increase as a result of a short circuit fault condition, this feature will prevent destruction of the transmitter output stage.

If the junction temperature exceeds approximately 160 °C, the limiting current of both transmitter outputs is decreased. Because the transmitter is responsible for most of the power dissipated, this will result in reduced power dissipation and hence a lower chip temperature. All other parts of the IC will remain operational. The thermal protection is needed, in particular, when a bus line is short-circuited.

The CANH and CANL lines are also protected against electrical transients which may occur in an automotive environment.

Pin 8 (Rs) allows three different modes of operation to be selected: High-speed, Slope control and Standby.

For high-speed operation, the transmitter output transistors are simply switched on and off as fast as possible. In this mode, no measures are taken to limit the rise and fall slopes. A shielded cable is recommended to avoid RFI problems. High-speed mode is selected by connecting pin 8 to ground.

Slope control mode allows the use of an unshielded twisted pair or a parallel pair of wires as bus lines. To reduce RFI, the rise and fall slopes should be limited. The rise and fall slopes can be programmed with a resistor connected from pin 8 to ground. The slope is proportional to the current output at pin 8.

If a HIGH level is applied to pin 8, the circuit enters a low-current Standby mode. In this mode, the transmitter is switched off and the receiver is switched to a low current. If dominant bits are detected (differential bus voltage >0.9 V), RXD will be switched to a

LOW level. The microcontroller should react to this condition by switching the transceiver back to normal operation (via pin 8). Because the receiver is slower in Standby mode, the first message will be lost at higher bit rates.

**Table 4. Truth table of the CAN transceiver**

Supply	TXD	CANH	CANL	Bus state	RXD
4.5 V to 5.5 V	0	HIGH	LOW	dominant	0
4.5 V to 5.5 V	1 (or floating)	floating	floating	recessive	1 <sup>[1]</sup>
4.5 V < V <sub>CC</sub> < 5.5 V	X <sup>[2]</sup>	floating if V <sub>Rs</sub> > 0.75V <sub>CC</sub>	floating if V <sub>Rs</sub> > 0.75V <sub>CC</sub>	floating	X <sup>[1]</sup>
0 V < V <sub>CC</sub> < 4.5 V	floating	floating	floating	floating	X <sup>[2]</sup>

[1] If another bus node is transmitting a dominant bit, then RXD is logic 0.

[2] X = don't care.

**Table 5. Pin Rs summary**

Condition forced at pin Rs	Mode	Resulting voltage or current at pin Rs
V <sub>Rs</sub> > 0.75V <sub>CC</sub>	Standby	-I <sub>Rs</sub> < 10 μA
10 μA < -I <sub>Rs</sub> < 200 μA	Slope control	0.4V <sub>CC</sub> < V <sub>Rs</sub> < 0.6V <sub>CC</sub>
V <sub>Rs</sub> < 0.3V <sub>CC</sub>	High-speed	-I <sub>Rs</sub> < 500 μA

## 9. Limiting values

**Table 6. Limiting values**

In accordance with the Absolute Maximum Rating System (IEC 60134). All voltages are referenced to pin 2; positive input current.

Symbol	Parameter	Conditions	Min	Max	Unit
V <sub>CC</sub>	supply voltage		-0.3	+7.0	V
V <sub>n</sub>	DC voltage at pins 1, 4, 5 and 8		-0.3	V <sub>CC</sub> + 0.3	V
V <sub>6</sub>	DC voltage at pin 6 (CANL)	0 V < V <sub>CC</sub> < 5.5 V; TXD HIGH or floating	-36	+36	V
		0 V < V <sub>CC</sub> < 5.5 V; no time limit	<sup>[1]</sup> -36	+36	V
		0 V < V <sub>CC</sub> < 5.5 V; no time limit	<sup>[2]</sup> -36	+36	V
V <sub>7</sub>	DC voltage at pins 7 (CANH)	0 V < V <sub>CC</sub> < 5.5 V; no time limit	-36	+36	V
V <sub>tt</sub>	transient voltage at pins 6 and 7	see <a href="#">Figure 8</a>	-200	+200	V
T <sub>stg</sub>	storage temperature		-55	+150	°C
T <sub>amb</sub>	ambient temperature		-40	+125	°C
T <sub>vj</sub>	virtual junction temperature		<sup>[3]</sup> -40	+150	°C
V <sub>ESD</sub>	electrostatic discharge voltage		<sup>[4]</sup> -2500	+2500	V
			<sup>[5]</sup> -250	+250	V

[1] TXD is LOW. Short-circuit protection provided for slew rates up to 5 V/μs for voltages above +30 V.

[2] Short-circuit applied when TXD is HIGH, followed by TXD switched to LOW.

[3] In accordance with "IEC 60747-1". An alternative definition of virtual junction temperature is: T<sub>vj</sub> = T<sub>amb</sub> + P<sub>d</sub> × R<sub>th(vj-a)</sub>, where R<sub>th(j-a)</sub> is a fixed value to be used for the calculation of T<sub>vj</sub>. The rating for T<sub>vj</sub> limits the allowable combinations of power dissipation (P<sub>d</sub>) and ambient temperature (T<sub>amb</sub>).

[4] Classification A: human body model; C = 100 pF; R = 1500 Ω; V = ±2000 V.

[5] Classification B: machine model; C = 200 pF; R = 25 Ω; V = ±200 V.

## 10. Thermal characteristics

Table 7. Thermal characteristics

Symbol	Parameter	Conditions	Typ	Unit
$R_{th(j-a)}$	thermal resistance from junction to ambient	in free air	160	K/W

## 11. Characteristics

Table 8. Characteristics

$V_{CC} = 4.5\text{ V to }5.5\text{ V}$ ;  $T_{amb} = -40\text{ °C to }+125\text{ °C}$ ;  $R_L = 60\ \Omega$ ;  $I_B > -10\ \mu\text{A}$ ; unless otherwise specified; all voltages referenced to ground (pin 2); positive input current; all parameters are guaranteed over the ambient temperature range by design, but only 100 % tested at +25 °C.

Symbol	Parameter	Conditions	Min	Typ	Max	Unit	
<b>Supply</b>							
$I_3$	supply current	dominant; $V_1 = 1\text{ V}$ ; $V_{CC} = 5.1\text{ V}$	-	-	78	mA	
		dominant; $V_1 = 1\text{ V}$ ; $V_{CC} = 5.25\text{ V}$	-	-	80	mA	
		dominant; $V_1 = 1\text{ V}$ ; $V_{CC} = 5.5\text{ V}$	-	-	85	mA	
		recessive; $V_1 = 4\text{ V}$ ; $R_8 = 47\text{ k}\Omega$	-	-	10	mA	
		Standby	[1]	-	-	275	$\mu\text{A}$
<b>DC bus transmitter</b>							
$V_{IH}$	HIGH-level input voltage	output recessive	$0.7V_{CC}$	-	$V_{CC} + 0.3$	V	
$V_{IL}$	LOW-level input voltage	output dominant	-0.3	-	$0.3V_{CC}$	V	
$I_{IH}$	HIGH-level input current	$V_1 = 4\text{ V}$	-200	-	+30	$\mu\text{A}$	
$I_{IL}$	LOW-level input current	$V_1 = 1\text{ V}$	-100	-	-600	$\mu\text{A}$	
$V_{6,7}$	recessive bus voltage	$V_1 = 4\text{ V}$ ; no load	2.0	-	3.0	V	
$I_{LO}$	off-state output leakage current	$-2\text{ V} < (V_6, V_7) < 7\text{ V}$	-2	-	+2	mA	
		$-5\text{ V} < (V_6, V_7) < 36\text{ V}$	-10	-	+10	mA	
$V_7$	CANH output voltage	$V_1 = 1\text{ V}$ ; $V_{CC} = 4.75\text{ V to }5.5\text{ V}$	3.0	-	4.5	V	
		$V_1 = 1\text{ V}$ ; $V_{CC} = 4.5\text{ V to }4.75\text{ V}$	2.75	-	4.5		
$V_6$	CANL output voltage	$V_1 = 1\text{ V}$	0.5	-	2.0	V	
$\Delta V_{6,7}$	difference between output voltage at pins 6 and 7	$V_1 = 1\text{ V}$	1.5	-	3.0	V	
		$V_1 = 1\text{ V}$ ; $R_L = 45\ \Omega$	1.5	-	-	V	
		$V_1 = 4\text{ V}$ ; no load	-500	-	+50	mV	
$I_{sc7}$	short-circuit CANH current	$V_7 = -5\text{ V}$	-	-	-200	mA	
		$V_7 = -36\text{ V}$	-	-100	-	mA	
$I_{sc6}$	short-circuit CANL current	$V_6 = 36\text{ V}$	-	-	200	mA	
<b>DC bus receiver: <math>V_1 = 4\text{ V}</math>; pins 6 and 7 externally driven; <math>-2\text{ V} &lt; (V_6, V_7) &lt; 7\text{ V}</math>; unless otherwise specified</b>							
$V_{diff(r)}$	differential input voltage (recessive)		[2]	-1.0	-	+0.5	V
		$-7\text{ V} < (V_6, V_7) < 12\text{ V}$	[2]	-1.0	-	+0.4	V
$V_{diff(d)}$	differential input voltage (dominant)			0.9	-	5.0	V
		$-7\text{ V} < (V_6, V_7) < 12\text{ V}$ ; not Standby mode		1.0	-	5.0	V
		Standby mode		0.97	-	5.0	V
		Standby mode; $V_{CC} = 4.5\text{ V to }5.10\text{ V}$		0.91	-	5.0	V

**Table 8. Characteristics ...continued**

$V_{CC} = 4.5\text{ V to }5.5\text{ V}$ ;  $T_{amb} = -40\text{ °C to }+125\text{ °C}$ ;  $R_L = 60\ \Omega$ ;  $I_8 > -10\ \mu\text{A}$ ; unless otherwise specified; all voltages referenced to ground (pin 2); positive input current; all parameters are guaranteed over the ambient temperature range by design, but only 100 % tested at +25 °C.

Symbol	Parameter	Conditions	Min	Typ	Max	Unit
$V_{diff(hys)}$	differential input hysteresis	see <a href="#">Figure 5</a>	-	150	-	mV
$V_{OH}$	HIGH-level output voltage	pin 4; $I_4 = -100\ \mu\text{A}$	$0.8V_{CC}$	-	$V_{CC}$	V
$V_{OL}$	LOW-level output voltage	pin 4; $I_4 = 1\text{ mA}$	0	-	$0.2V_{CC}$	V
		$I_4 = 10\text{ mA}$	0	-	1.5	V
$R_i$	input resistance	CANH, CANL	5	-	25	k $\Omega$
$R_{diff}$	differential input resistance		20	-	100	k $\Omega$
<b>Reference output</b>						
$V_{ref}$	reference output voltage	$V_8 = 1\text{ V}$ ; $ I_5  < 50\ \mu\text{A}$	$0.45V_{CC}$	-	$0.55V_{CC}$	V
		$V_8 = 4\text{ V}$ ; $ I_5  < 5\ \mu\text{A}$	$0.4V_{CC}$	-	$0.6V_{CC}$	V
<b>Timing (<math>C_L = 100\text{ pF}</math>; see <a href="#">Figure 3</a>, <a href="#">Figure 4</a>, <a href="#">Figure 6</a> and <a href="#">Figure 7</a>)</b>						
$t_{bit}$	minimum bit time	$R_{ext} = 0\ \Omega$	-	-	1	$\mu\text{s}$
$t_{onTXD}$	delay TXD to bus active	$R_{ext} = 0\ \Omega$	-	-	50	ns
$t_{offTXD}$	delay TXD to bus inactive	$R_{ext} = 0\ \Omega$	-	40	80	ns
$t_{onRXD}$	delay TXD to receiver active	$R_{ext} = 0\ \Omega$	-	55	120	ns
$t_{offRXD}$	delay TXD to receiver inactive	$R_{ext} = 0\ \Omega$ ; $T_{amb} < +85\text{ °C}$ $V_{CC} = 4.5\text{ V to }5.1\text{ V}$	-	80	150	ns
		$R_{ext} = 0\ \Omega$ ; $V_{CC} = 4.5\text{ V to }5.1\text{ V}$	-	80	170	ns
		$R_{ext} = 0\ \Omega$ ; $T_{amb} < +85\text{ °C}$	-	90	170	ns
		$R_{ext} = 0\text{ k}\Omega$	-	90	190	ns
		$R_{ext} = 47\text{ k}\Omega$	-	290	400	ns
$t_{onRXD}$	delay TXD to receiver active	$R_{ext} = 47\text{ k}\Omega$	-	440	550	ns
$ SR $	CANH, CANL slew rate	$R_{ext} = 47\text{ k}\Omega$	-	7	-	V/ $\mu\text{s}$
$t_{WAKE}$	wake-up time from Standby (via pin 8)	see <a href="#">Figure 6</a>	-	-	20	$\mu\text{s}$
$t_{dRXDL}$	bus dominant to RXD LOW	$V_8 = 4\text{ V}$ ; see <a href="#">Figure 7</a>	-	-	3	$\mu\text{s}$
<b>Standby/Slope control (pin 8)</b>						
$V_{stb}$	input voltage for Standby mode		$0.75V_{CC}$	-	-	V
$I_{slope}$	Slope control mode current		-10	-	-200	$\mu\text{A}$
$V_{slope}$	Slope control mode voltage		$0.4V_{CC}$	-	$0.6V_{CC}$	V

[1]  $I_1 = I_4 = I_5 = 0\text{ mA}$ ;  $0\text{ V} < V_6 < V_{CC}$ ;  $0\text{ V} < V_7 < V_{CC}$ ;  $V_8 = V_{CC}$ ;  $T_{amb} < 90\text{ °C}$ .

[2] This is valid for the receiver in all modes: High-speed, Slope control and Standby.

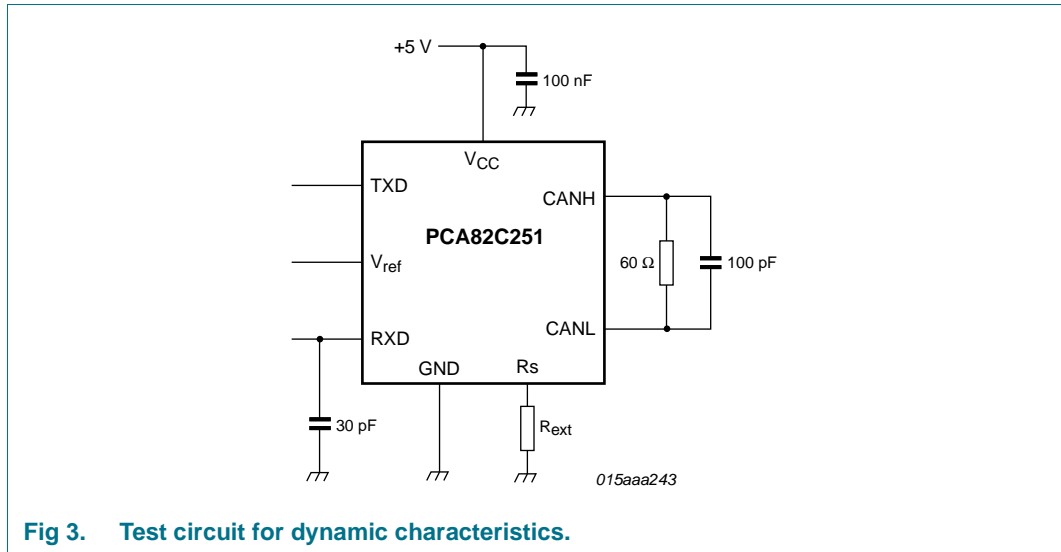

Fig 3. Test circuit for dynamic characteristics.

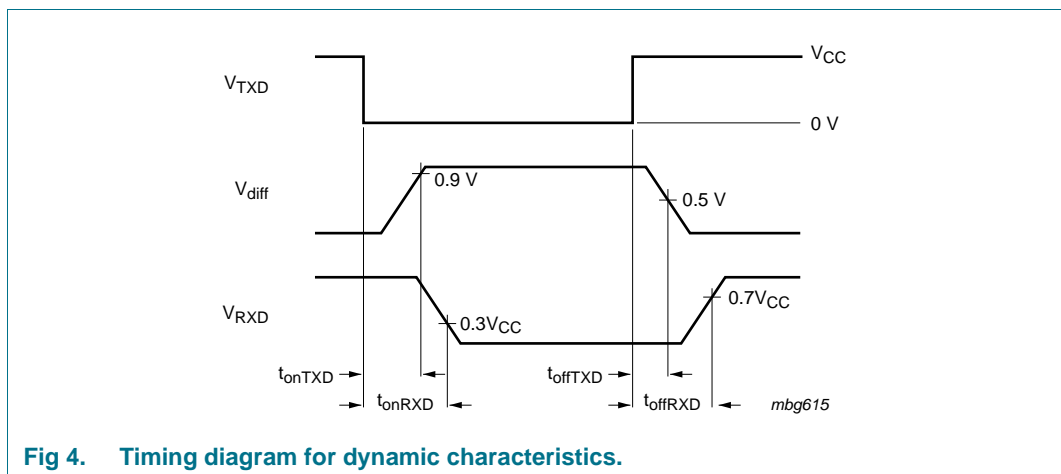

Fig 4. Timing diagram for dynamic characteristics.

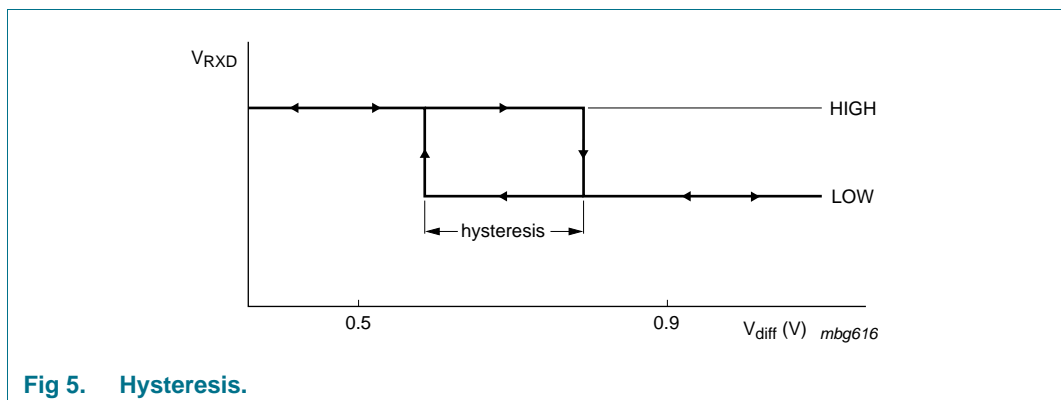
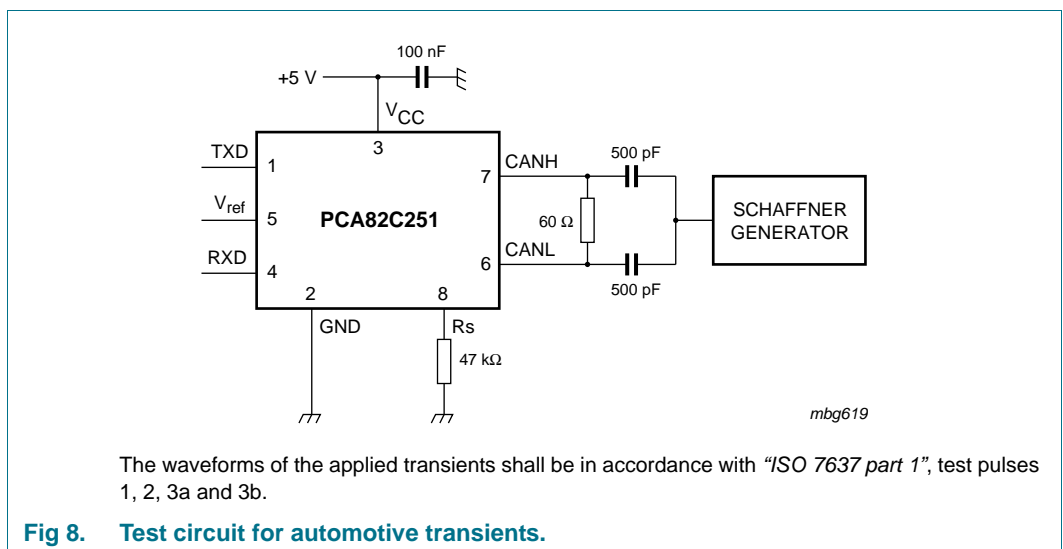
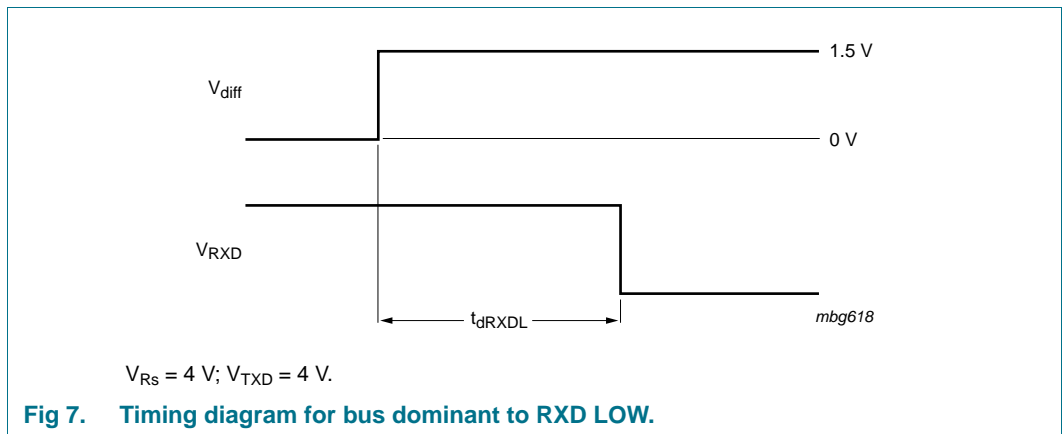
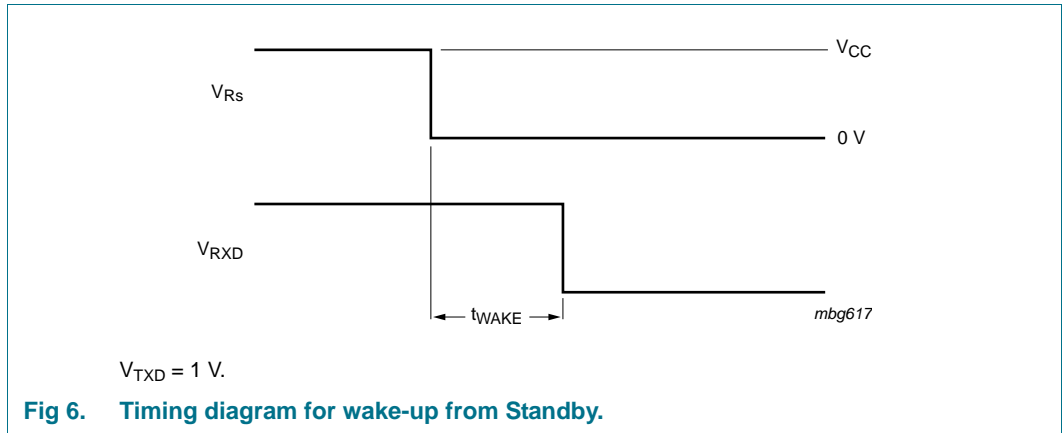
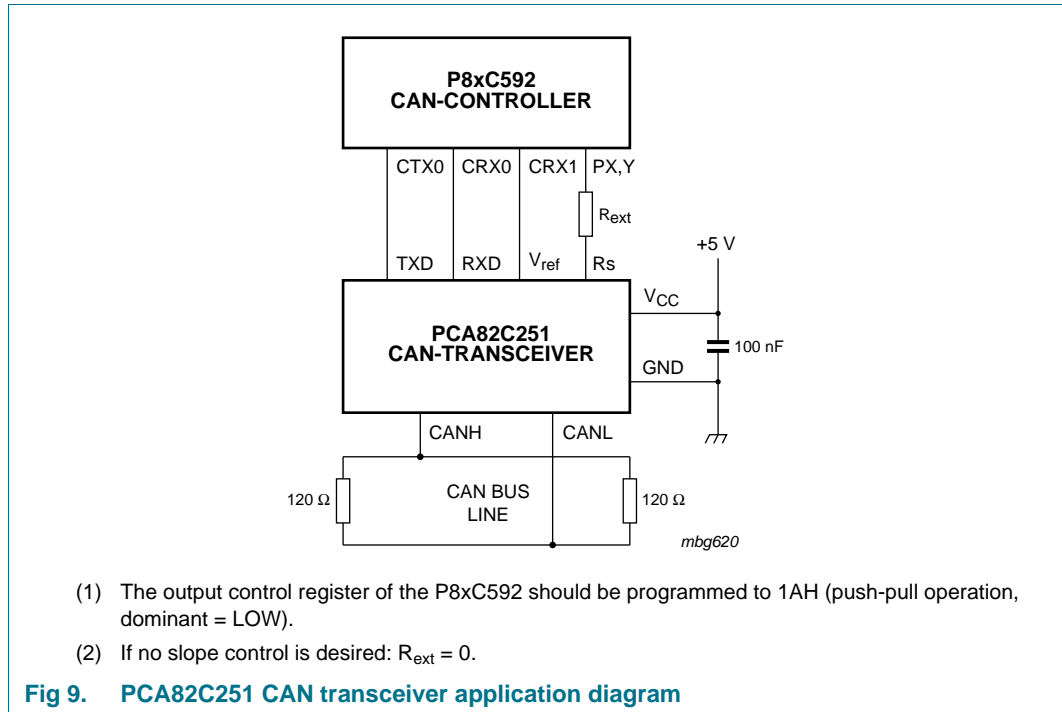

Fig 5. Hysteresis.





## 12. Application information



13. Package outline

SO8: plastic small outline package; 8 leads; body width 3.9 mm

SOT96-1

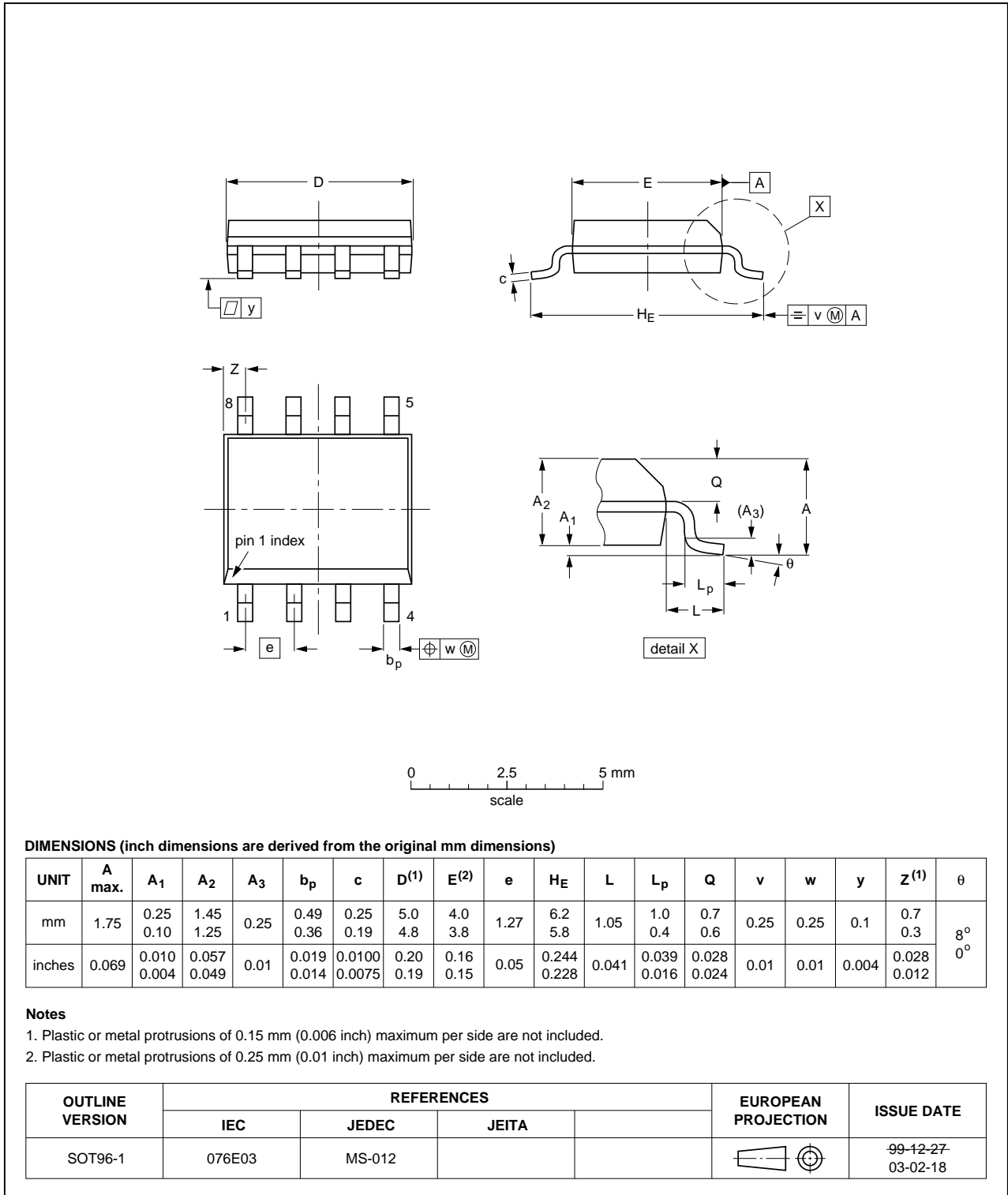

Fig 10. Package outline SOT96-1 (SO8)

## 14. Soldering of SMD packages

This text provides a very brief insight into a complex technology. A more in-depth account of soldering ICs can be found in Application Note *AN10365 "Surface mount reflow soldering description"*.

### 14.1 Introduction to soldering

Soldering is one of the most common methods through which packages are attached to Printed Circuit Boards (PCBs), to form electrical circuits. The soldered joint provides both the mechanical and the electrical connection. There is no single soldering method that is ideal for all IC packages. Wave soldering is often preferred when through-hole and Surface Mount Devices (SMDs) are mixed on one printed wiring board; however, it is not suitable for fine pitch SMDs. Reflow soldering is ideal for the small pitches and high densities that come with increased miniaturization.

### 14.2 Wave and reflow soldering

Wave soldering is a joining technology in which the joints are made by solder coming from a standing wave of liquid solder. The wave soldering process is suitable for the following:

- Through-hole components
- Leaded or leadless SMDs, which are glued to the surface of the printed circuit board

Not all SMDs can be wave soldered. Packages with solder balls, and some leadless packages which have solder lands underneath the body, cannot be wave soldered. Also, leaded SMDs with leads having a pitch smaller than ~0.6 mm cannot be wave soldered, due to an increased probability of bridging.

The reflow soldering process involves applying solder paste to a board, followed by component placement and exposure to a temperature profile. Leaded packages, packages with solder balls, and leadless packages are all reflow solderable.

Key characteristics in both wave and reflow soldering are:

- Board specifications, including the board finish, solder masks and vias
- Package footprints, including solder thieves and orientation
- The moisture sensitivity level of the packages
- Package placement
- Inspection and repair
- Lead-free soldering versus SnPb soldering

### 14.3 Wave soldering

Key characteristics in wave soldering are:

- Process issues, such as application of adhesive and flux, clinching of leads, board transport, the solder wave parameters, and the time during which components are exposed to the wave
- Solder bath specifications, including temperature and impurities

## 14.4 Reflow soldering

Key characteristics in reflow soldering are:

- Lead-free versus SnPb soldering; note that a lead-free reflow process usually leads to higher minimum peak temperatures (see [Figure 11](#)) than a SnPb process, thus reducing the process window
- Solder paste printing issues including smearing, release, and adjusting the process window for a mix of large and small components on one board
- Reflow temperature profile; this profile includes preheat, reflow (in which the board is heated to the peak temperature) and cooling down. It is imperative that the peak temperature is high enough for the solder to make reliable solder joints (a solder paste characteristic). In addition, the peak temperature must be low enough that the packages and/or boards are not damaged. The peak temperature of the package depends on package thickness and volume and is classified in accordance with [Table 9](#) and [10](#)

**Table 9. SnPb eutectic process (from J-STD-020C)**

Package thickness (mm)	Package reflow temperature (°C)	
	Volume (mm <sup>3</sup> )	
	< 350	≥ 350
< 2.5	235	220
≥ 2.5	220	220

**Table 10. Lead-free process (from J-STD-020C)**

Package thickness (mm)	Package reflow temperature (°C)		
	Volume (mm <sup>3</sup> )		
	< 350	350 to 2000	> 2000
< 1.6	260	260	260
1.6 to 2.5	260	250	245
> 2.5	250	245	245

Moisture sensitivity precautions, as indicated on the packing, must be respected at all times.

Studies have shown that small packages reach higher temperatures during reflow soldering, see [Figure 11](#).

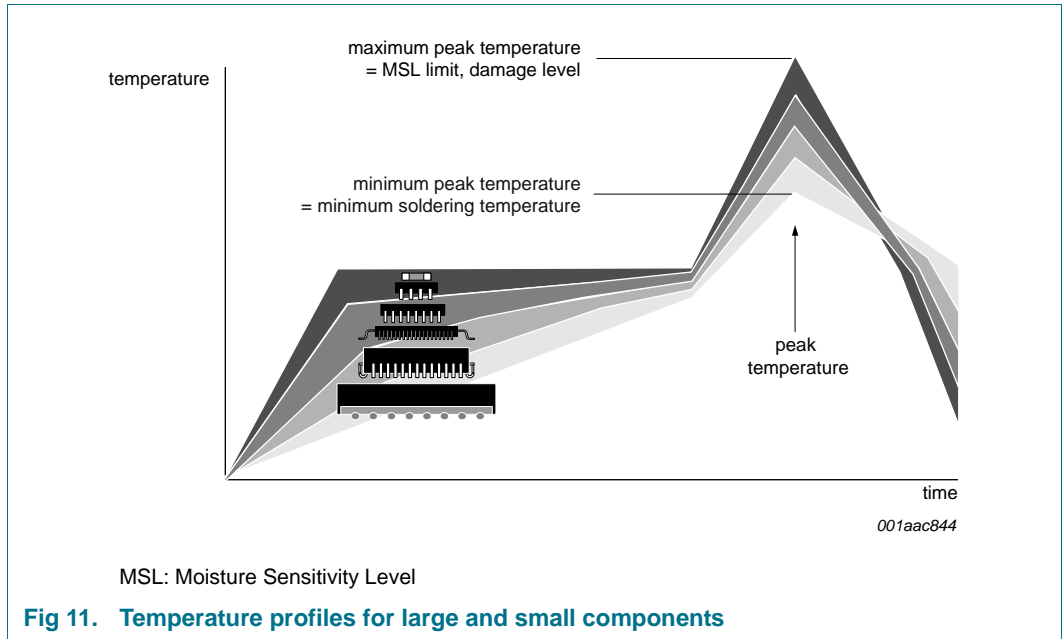

For further information on temperature profiles, refer to Application Note AN10365 “Surface mount reflow soldering description”.

## 15. Revision history

Table 11. Revision history

Document ID	Release date	Data sheet status	Change notice	Supersedes
PCA82C251_4	20110825	Product data sheet	-	PCA82C251_3
Modifications:		<ul style="list-style-type: none"><li>• The format of this data sheet has been redesigned to comply with the new identity guidelines of NXP Semiconductors.</li><li>• Legal texts have been adapted to the new company name where appropriate.</li><li>• DIP8 package discontinued; bare die no longer available.</li><li>• <a href="#">Section 4 "Quick reference data"</a> <math>t_{PD}</math> propagation delay added.</li><li>• Typing errors corrected in <a href="#">Table 8</a> and <a href="#">Figure 3</a>.</li></ul>		
PCA82C251_3	20000113	Product data sheet	-	PCA82C251_2
PCA82C251_2	19970314	Product data sheet	-	PCA82C251_1
PCA82C251_1	-	Product data sheet	-	-

## 16. Legal information

### 16.1 Data sheet status

Document status <sup>[1][2]</sup>	Product status <sup>[3]</sup>	Definition
Objective [short] data sheet	Development	This document contains data from the objective specification for product development.
Preliminary [short] data sheet	Qualification	This document contains data from the preliminary specification.
Product [short] data sheet	Production	This document contains the product specification.

[1] Please consult the most recently issued document before initiating or completing a design.

[2] The term 'short data sheet' is explained in section "Definitions".

[3] The product status of device(s) described in this document may have changed since this document was published and may differ in case of multiple devices. The latest product status information is available on the Internet at URL <http://www.nxp.com>.

### 16.2 Definitions

**Draft** — The document is a draft version only. The content is still under internal review and subject to formal approval, which may result in modifications or additions. NXP Semiconductors does not give any representations or warranties as to the accuracy or completeness of information included herein and shall have no liability for the consequences of use of such information.

**Short data sheet** — A short data sheet is an extract from a full data sheet with the same product type number(s) and title. A short data sheet is intended for quick reference only and should not be relied upon to contain detailed and full information. For detailed and full information see the relevant full data sheet, which is available on request via the local NXP Semiconductors sales office. In case of any inconsistency or conflict with the short data sheet, the full data sheet shall prevail.

**Product specification** — The information and data provided in a Product data sheet shall define the specification of the product as agreed between NXP Semiconductors and its customer, unless NXP Semiconductors and customer have explicitly agreed otherwise in writing. In no event however, shall an agreement be valid in which the NXP Semiconductors product is deemed to offer functions and qualities beyond those described in the Product data sheet.

### 16.3 Disclaimers

**Limited warranty and liability** — Information in this document is believed to be accurate and reliable. However, NXP Semiconductors does not give any representations or warranties, expressed or implied, as to the accuracy or completeness of such information and shall have no liability for the consequences of use of such information.

In no event shall NXP Semiconductors be liable for any indirect, incidental, punitive, special or consequential damages (including - without limitation - lost profits, lost savings, business interruption, costs related to the removal or replacement of any products or rework charges) whether or not such damages are based on tort (including negligence), warranty, breach of contract or any other legal theory.

Notwithstanding any damages that customer might incur for any reason whatsoever, NXP Semiconductors' aggregate and cumulative liability towards customer for the products described herein shall be limited in accordance with the *Terms and conditions of commercial sale* of NXP Semiconductors.

**Right to make changes** — NXP Semiconductors reserves the right to make changes to information published in this document, including without limitation specifications and product descriptions, at any time and without notice. This document supersedes and replaces all information supplied prior to the publication hereof.

**Suitability for use in automotive applications** — This NXP Semiconductors product has been qualified for use in automotive applications. The product is not designed, authorized or warranted to be

suitable for use in medical, military, aircraft, space or life support equipment, nor in applications where failure or malfunction of an NXP Semiconductors product can reasonably be expected to result in personal injury, death or severe property or environmental damage. NXP Semiconductors accepts no liability for inclusion and/or use of NXP Semiconductors products in such equipment or applications and therefore such inclusion and/or use is at the customer's own risk.

**Applications** — Applications that are described herein for any of these products are for illustrative purposes only. NXP Semiconductors makes no representation or warranty that such applications will be suitable for the specified use without further testing or modification.

Customers are responsible for the design and operation of their applications and products using NXP Semiconductors products, and NXP Semiconductors accepts no liability for any assistance with applications or customer product design. It is customer's sole responsibility to determine whether the NXP Semiconductors product is suitable and fit for the customer's applications and products planned, as well as for the planned application and use of customer's third party customer(s). Customers should provide appropriate design and operating safeguards to minimize the risks associated with their applications and products.

NXP Semiconductors does not accept any liability related to any default, damage, costs or problem which is based on any weakness or default in the customer's applications or products, or the application or use by customer's third party customer(s). Customer is responsible for doing all necessary testing for the customer's applications and products using NXP Semiconductors products in order to avoid a default of the applications and the products or of the application or use by customer's third party customer(s). NXP does not accept any liability in this respect.

**Limiting values** — Stress above one or more limiting values (as defined in the Absolute Maximum Ratings System of IEC 60134) will cause permanent damage to the device. Limiting values are stress ratings only and (proper) operation of the device at these or any other conditions above those given in the Recommended operating conditions section (if present) or the Characteristics sections of this document is not warranted. Constant or repeated exposure to limiting values will permanently and irreversibly affect the quality and reliability of the device.

**Terms and conditions of commercial sale** — NXP Semiconductors products are sold subject to the general terms and conditions of commercial sale, as published at <http://www.nxp.com/profile/terms>, unless otherwise agreed in a valid written individual agreement. In case an individual agreement is concluded only the terms and conditions of the respective agreement shall apply. NXP Semiconductors hereby expressly objects to applying the customer's general terms and conditions with regard to the purchase of NXP Semiconductors products by customer.

**No offer to sell or license** — Nothing in this document may be interpreted or construed as an offer to sell products that is open for acceptance or the grant, conveyance or implication of any license under any copyrights, patents or other industrial or intellectual property rights.

**Export control** — This document as well as the item(s) described herein may be subject to export control regulations. Export might require a prior authorization from national authorities.

**Quick reference data** — The Quick reference data is an extract of the product data given in the Limiting values and Characteristics sections of this document, and as such is not complete, exhaustive or legally binding.

## 16.4 Trademarks

Notice: All referenced brands, product names, service names and trademarks are the property of their respective owners.

## 17. Contact information

---

For more information, please visit: <http://www.nxp.com>

For sales office addresses, please send an email to: [salesaddresses@nxp.com](mailto:salesaddresses@nxp.com)



## 18. Contents

<b>1</b>	<b>General description</b> .....	<b>1</b>
<b>2</b>	<b>Features and benefits</b> .....	<b>1</b>
<b>3</b>	<b>Applications</b> .....	<b>1</b>
<b>4</b>	<b>Quick reference data</b> .....	<b>1</b>
<b>5</b>	<b>Ordering information</b> .....	<b>2</b>
<b>6</b>	<b>Block diagram</b> .....	<b>2</b>
<b>7</b>	<b>Pinning information</b> .....	<b>2</b>
7.1	Pinning .....	2
7.2	Pin description .....	3
<b>8</b>	<b>Functional description</b> .....	<b>3</b>
<b>9</b>	<b>Limiting values</b> .....	<b>4</b>
<b>10</b>	<b>Thermal characteristics</b> .....	<b>5</b>
<b>11</b>	<b>Characteristics</b> .....	<b>5</b>
<b>12</b>	<b>Application information</b> .....	<b>9</b>
<b>13</b>	<b>Package outline</b> .....	<b>10</b>
<b>14</b>	<b>Soldering of SMD packages</b> .....	<b>11</b>
14.1	Introduction to soldering .....	11
14.2	Wave and reflow soldering .....	11
14.3	Wave soldering .....	11
14.4	Reflow soldering .....	12
<b>15</b>	<b>Revision history</b> .....	<b>14</b>
<b>16</b>	<b>Legal information</b> .....	<b>15</b>
16.1	Data sheet status .....	15
16.2	Definitions .....	15
16.3	Disclaimers .....	15
16.4	Trademarks .....	16
<b>17</b>	<b>Contact information</b> .....	<b>16</b>
<b>18</b>	<b>Contents</b> .....	<b>17</b>

Please be aware that important notices concerning this document and the product(s) described herein, have been included in section 'Legal information'.

© NXP B.V. 2011.

All rights reserved.

For more information, please visit: <http://www.nxp.com>

For sales office addresses, please send an email to: [salesaddresses@nxp.com](mailto:salesaddresses@nxp.com)

Date of release: 25 August 2011

Document identifier: PCA82C251