

engineering TUBE DATA

KUTHE
8370 *

from JEDEC release #3993,
Nov. 26, 1962



Components Division

T E N T A T I V E

DESCRIPTION:

* THE 8370 IS A UNIPOTENTIAL CATHODE THREE ELEMENT HYDROGEN THYRATRON. AN ELECTRICALLY HEATED TITANIUM HYDRIDE RESERVOIR IS CONNECTED INTERNALLY ACROSS THE CATHODE HEATERS. THE 8370 WAS DEVELOPED TO MEET THE NEEDS OF THE MODULATOR DESIGNER FOR A LOW PLATE VOLTAGE THYRATRON FOR OPERATION AT A HIGH DUTY CYCLE.

ELECTRICAL DATA, GENERAL:

	<u>NOM.</u>	<u>MIN.</u>	<u>MAX.</u>	
HEATER VOLTAGE	6.3	5.7	6.6	VOLTS AC
HEATER CURRENT (AT 6.3 VOLTS)		5.5	6.7	AMPERES
MINIMUM HEATING TIME				3 MINUTES

MECHANICAL DATA, GENERAL:

MOUNTING POSITION		ANY
BASE		PER OUTLINE
COOLING (NOTE 1)		
NET WEIGHT	0.3	POUNDS
DIMENSIONS		PER OUTLINE

RATINGS:

MAX. PEAK ANODE VOLTAGE, FORWARD	5.0	KILOVOLTS
MAX. PEAK ANODE VOLTAGE, INVERSE (NOTE 2)	5.0	KILOVOLTS
MIN. ANODE SUPPLY VOLTAGE	0.3	KILOVOLTS DC
MAX. PEAK ANODE CURRENT	85	AMPERES
MAX. AVERAGE ANODE CURRENT	100	MILLIAMPERES
MAX. RMS ANODE CURRENT (NOTE 3)	2.9	AMPERES AC
MAX. EPY X IB X PRR	2.5	$\times 10^9$
MAX. ANODE CURRENT RATE OF RISE	1200	AMPS / μ SEC.
PEAK TRIGGER VOLTAGE (NOTE 4)		
MAX. ANODE DELAY TIME (NOTE 5)	0.6	MICROSECOND
MAX. ANODE DELAY TIME DRIFT	0.15	MICROSECOND
MAX. TIME JITTER (NOTE 6)	0.01	MICROSECOND
AMBIENT TEMPERATURE	-50° to +90°	C

* THIS TUBE WAS PREVIOUSLY DESIGNATED BY TYPE NUMBER E-38.



ELECTRON TUBE DEPARTMENT
COMPONENTS DIVISION

INTERNATIONAL TELEPHONE AND TELEGRAPH CORPORATION

P. O. BOX 412, CLIFTON, NEW JERSEY

11-62

NOTE 1:

COOLING OF THE ANODE LEAD IS PERMISSIBLE, BUT THERE SHALL BE NO AIR BLAST DIRECTLY ON THE BULB.

NOTE 2:

IN PULSED OPERATION, THE PEAK INVERSE VOLTAGE, EXCLUSIVE OF SPIKE OF .05 US MAXIMUM DURATION, SHALL NOT EXCEED 2000 V DURING THE FIRST 25 US AFTER THE PULSE.

NOTE 3:

THE ROOT MEAN SQUARE ANODE CURRENT SHALL BE COMPUTED AS THE SQUARE ROOT OF THE PRODUCT OF PEAK CURRENT AND THE AVERAGE CURRENT.

NOTE 4:

DRIVER PULSE, MEASURED AT TUBE SOCKET WITH THYRATRON GRID DISCONNECTED; EGY = 175 V (MIN.), TIME OF RISE = 0.5 US (MAX.), GRID PULSE DURATION = 2 US (MIN.), IMPEDANCE OF DRIVER CIRCUIT = 1500 OHMS (MAX.).

NOTE 5:

THE TIME OF ANODE DELAY IS MEASURED BETWEEN THE 26 PER CENT POINT ON THE RISING PORTION OF THE UNLOADED GRID VOLTAGE PULSE AND THE POINT AT WHICH ANODE CONDUCTION FIRST EVIDENCES ITSELF ON THE LOADED GRID PULSE.

NOTE 6:

TIME JITTER IS MEASURED AT THE 50 PER CENT POINT ON THE ANODE CURRENT PULSE.

ADDITIONAL INFORMATION FOR SPECIFIC APPLICATIONS CAN BE OBTAINED FROM THE

ELECTRON TUBE APPLICATIONS SECTION
ITT COMPONENTS DIVISION
POST OFFICE BOX 412
CLIFTON, NEW JERSEY

OUTLINE
8370

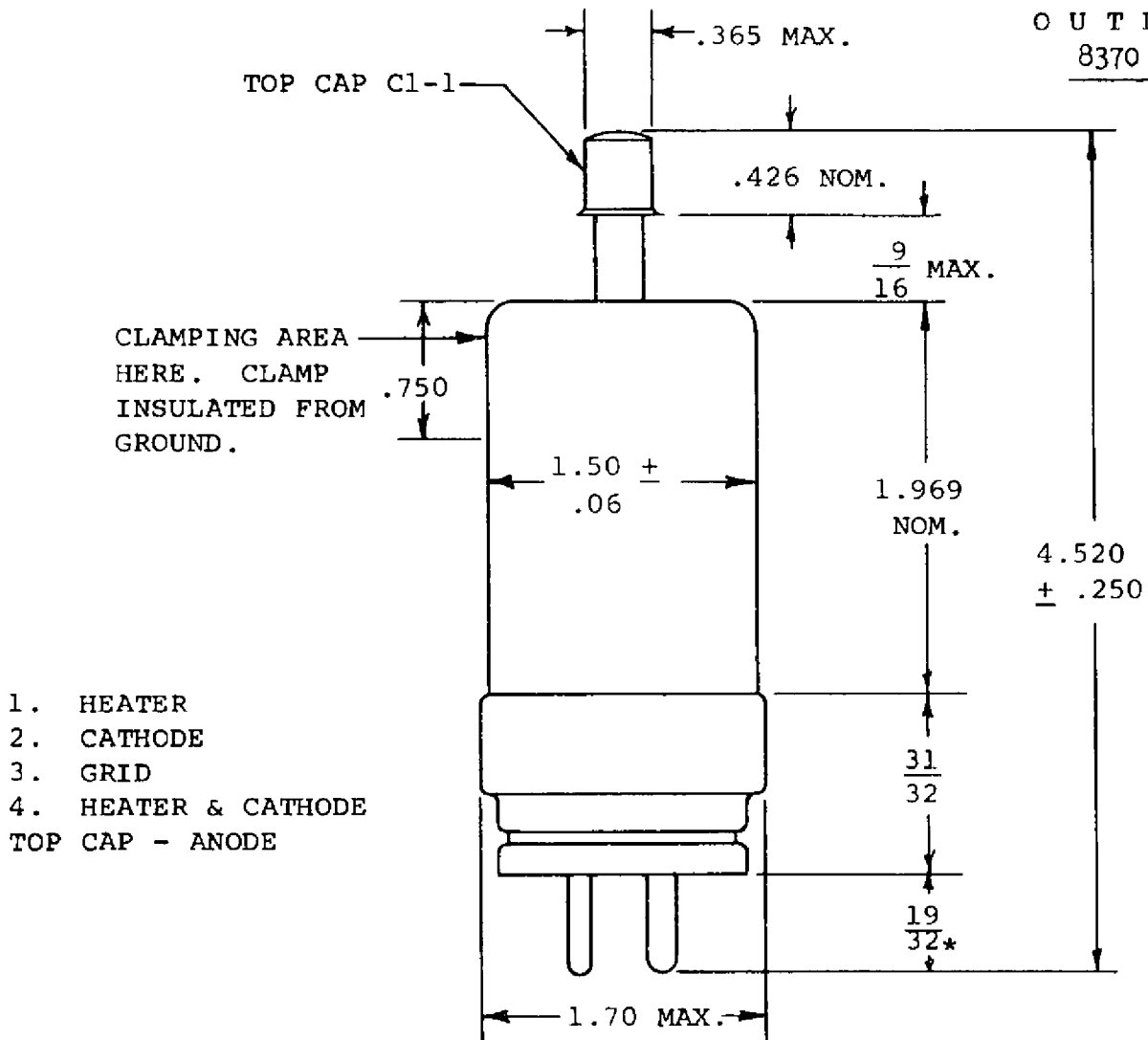

*ON FINISHED TUBE ADD .030
FOR SOLDER

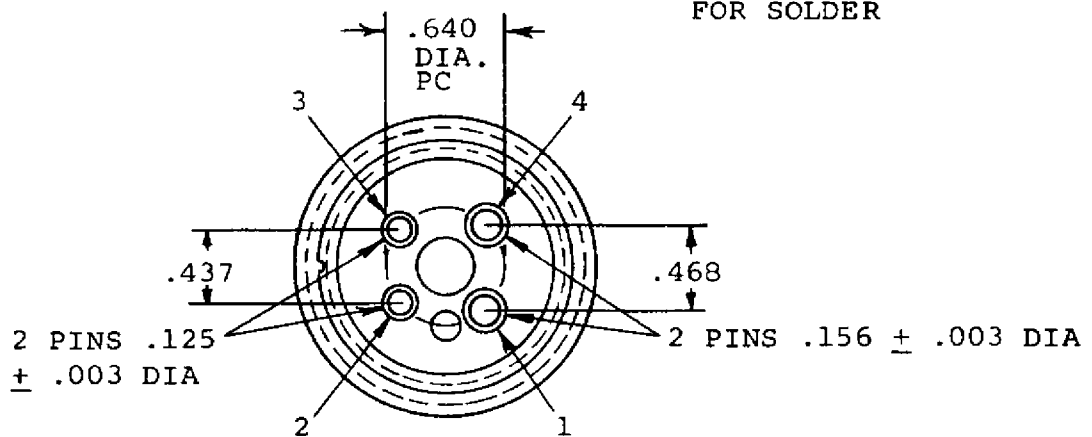

PIN ARRANGEMENT AND DIMENSIONS ONLY
AS PER A4-9 MIL-E-1C