

REVISIONS			
LTR	DESCRIPTION	DATE (YR-MO-DA)	APPROVED
A	Change to military drawing format. Changes to output adjustment range. Add conditions for load regulation test at -55°C and +125°C. Change group A subgroups for load regulation and line regulation tests, and output voltage temperature coefficient. Add vendor CAGE 64155. Editorial changes throughout.	88-03-17	M. A. FRYE
B	Add vendor CAGE 07933. Add vendor CAGE 54186. Add case outline 2. Change output voltage temperature coefficient test limits.	89-04-12	M. A. FRYE
C	Add device type 02. Editorial changes throughout. Delete vendors CAGEs 54186 and 07933. Add vendor CAGE 1ES66.	92-11-25	M. A. FRYE
D	Add class V devices. Replace CAGE 06665 with 24355. Add case outline H and TABLE IIB. Make changes to 1.2.2 and TABLE II.	97-06-10	R. MONNIN
E	Add radiation hardness assurance requirements. - ro	98-08-07	R. MONNIN
F	Make changes to 1.5, table IIA, 4.4.1b, and output voltage temperature coefficient test as specified in table I. - ro	00-01-21	R. MONNIN
G	Add device types 03 and 04. Make changes 1.2.2 and to the output voltage noise test as specified under TABLE I. - ro	01-02-07	R. MONNIN

THE ORIGINAL FIRST SHEET OF THIS DRAWING HAS BEEN REPLACED.

CURRENT CAGE CODE 67268

REV																				
SHEET																				
REV																				
SHEET																				
REV STATUS	REV	G	G	G	G	G	G	G	G	G	G	G	G	G						
OF SHEETS	SHEET	1	2	3	4	5	6	7	8	9	10	11								
PMIC N/A	PREPARED BY JOSEPH A. KERBY	<b>DEFENSE SUPPLY CENTER COLUMBUS</b> <b>COLUMBUS, OHIO 43216</b> <a href="http://www.dsc.dla.mil">http://www.dsc.dla.mil</a>																		
<b>STANDARD MICROCIRCUIT DRAWING</b>  THIS DRAWING IS AVAILABLE FOR USE BY ALL DEPARTMENTS AND AGENCIES OF THE DEPARTMENT OF DEFENSE  AMSC N/A	CHECKED BY RAY MONNIN																			
	APPROVED BY MICHAEL A. FRYE	<b>MICROCIRCUIT, LINEAR, RADIATION HARDENED, +5 VOLT ADJUSTABLE PRECISION VOLTAGE REFERENCE, MONOLITHIC SILICON</b>																		
	DRAWING APPROVAL DATE 86-03-08																			
	REVISION LEVEL G	SIZE A	CAGE CODE <b>14933</b>	<b>85514</b>																
		SHEET 1 OF 11																		

1. SCOPE

1.1 Scope. This drawing documents two product assurance class levels consisting of high reliability (device classes Q and M) and space application (device class V). A choice of case outlines and lead finishes are available and are reflected in the Part or Identifying Number (PIN). When available, a choice of Radiation Hardness Assurance (RHA) levels are reflected in the PIN.

1.2 PIN. The PIN is as shown in the following examples.

For device classes M and Q:

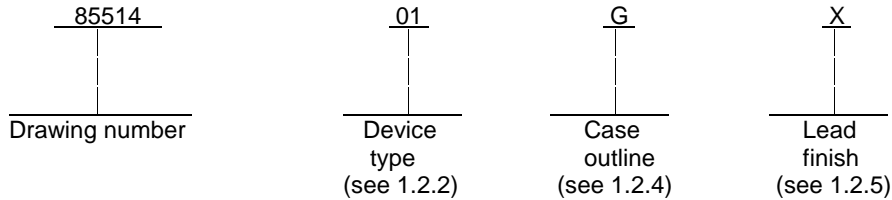

For device class V:

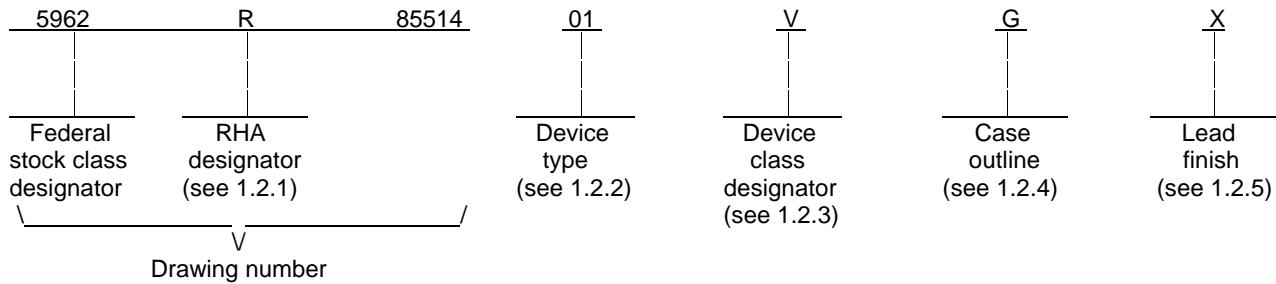

1.2.1 RHA designator. Device classes Q and V RHA marked devices meet the MIL-PRF-38535 specified RHA levels and are marked with the appropriate RHA designator. Device class M RHA marked devices meet the MIL-PRF-38535, appendix A specified RHA levels and are marked with the appropriate RHA designator. A dash (-) indicates a non-RHA device.

1.2.2 Device type(s). The device type(s) identify the circuit function as follows:

Device type	Generic number	Circuit function	Output voltage noise
01	REF02A	Precision reference +5-volt adjustable output	18 $\mu$ V <sub>P-P</sub>
02	REF02	Precision reference +5-volt adjustable output	18 $\mu$ V <sub>P-P</sub>
03	REF02A	Precision reference +5-volt adjustable output	100 $\mu$ V <sub>P-P</sub>
04	REF02	Precision reference +5-volt adjustable output	100 $\mu$ V <sub>P-P</sub>

<b>STANDARD MICROCIRCUIT DRAWING</b> DEFENSE SUPPLY CENTER COLUMBUS COLUMBUS, OHIO 43216-5000	SIZE <b>A</b>		<b>85514</b>
		REVISION LEVEL <b>G</b>	SHEET <b>2</b>

1.2.3 Device class designator. The device class designator is a single letter identifying the product assurance level as listed below. Since the device class designator has been added after the original issuance of this drawing, device classes M and Q designators will not be included in the PIN and will not be marked on the device.

<u>Device class</u>	<u>Device requirements documentation</u>
M	Vendor self-certification to the requirements for MIL-STD-883 compliant, non-JAN class level B microcircuits in accordance with MIL-PRF-38535, appendix A
Q or V	Certification and qualification to MIL-PRF-38535

1.2.4 Case outline(s). The case outline(s) are as designated in MIL-STD-1835 and as follows:

<u>Outline letter</u>	<u>Descriptive designator</u>	<u>Terminals</u>	<u>Package style</u>
G	MACY1-X8	8	Can
H	GDFP1-F10 or CDFP2-F10	10	Flat pack
P	GDIP1-T8 or CDIP2-T8	8	Dual-in-line
2	CQCC1-N20	20	Square leadless chip carrier

1.2.5 Lead finish. The lead finish is as specified in MIL-PRF-38535 for device classes Q and V or MIL-PRF-38535, appendix A for device class M.

1.3 Absolute maximum ratings. 1/

Input voltage ( $V_{IN}$ ) .....	40 V dc
Power dissipation ( $P_D$ ).....	500 mW 2/
Output short circuit duration.....	Indefinite
Storage temperature .....	-65°C to +150°C
Lead temperature (soldering, 10 seconds) .....	+300°C
Junction temperature ( $T_J$ ) .....	+150°C
Thermal resistance, junction-to-case ( $\theta_{JC}$ ).....	See MIL-STD-1835

1.4 Recommended operating conditions.

Ambient operating temperature range ( $T_A$ ).....	-55°C to +125°C
--	-----------------

1.5 Radiation features.

Maximum total dose available (dose rate = 50 – 300 rads(Si) / s).....	100 Krads 3/
---	--------------

- 1/ Stresses above the absolute maximum rating may cause permanent damage to the device. Extended operation at the maximum levels may degrade performance and affect reliability.
- 2/ Derate 7.1 mW/°C above +80°C for the "G" and "H" packages, 6.6 mW/°C above +75°C for the "P" package, and 7.8 mW/°C above +72°C for the "2" package.
- 3/ These parts may be dose rate sensitive in a space environment and may demonstrate enhanced low dose rate effects. Radiation end point limits for the noted parameters are guaranteed only for the conditions specified in MIL-STD-883, method 1019, condition A.

<b>STANDARD MICROCIRCUIT DRAWING</b> DEFENSE SUPPLY CENTER COLUMBUS COLUMBUS, OHIO 43216-5000	SIZE <b>A</b>		<b>85514</b>
		REVISION LEVEL <b>G</b>	SHEET <b>3</b>

2. APPLICABLE DOCUMENTS

2.1 Government specification, standards, and handbooks. The following specification, standards, and handbooks form a part of this drawing to the extent specified herein. Unless otherwise specified, the issues of these documents are those listed in the issue of the Department of Defense Index of Specifications and Standards (DoDISS) and supplement thereto, cited in the solicitation.

SPECIFICATION

DEPARTMENT OF DEFENSE

MIL-PRF-38535 - Integrated Circuits, Manufacturing, General Specification for.

STANDARDS

DEPARTMENT OF DEFENSE

MIL-STD-883 - Test Method Standard Microcircuits.  
MIL-STD-1835 - Interface Standard Electronic Component Case Outlines.

HANDBOOKS

DEPARTMENT OF DEFENSE

MIL-HDBK-103 - List of Standard Microcircuit Drawings (SMD's).  
MIL-HDBK-780 - Standard Microcircuit Drawings.

(Unless otherwise indicated, copies of the specification, standards, and handbooks are available from the Standardization Document Order Desk, 700 Robbins Avenue, Building 4D, Philadelphia, PA 19111-5094.)

2.2 Order of precedence. In the event of a conflict between the text of this drawing and the references cited herein, the text of this drawing takes precedence. Nothing in this document, however, supersedes applicable laws and regulations unless a specific exemption has been obtained.

3. REQUIREMENTS

3.1 Item requirements. The individual item requirements for device classes Q and V shall be in accordance with MIL-PRF-38535 and as specified herein or as modified in the device manufacturer's Quality Management (QM) plan. The modification in the QM plan shall not affect the form, fit, or function as described herein. The individual item requirements for device class M shall be in accordance with MIL-PRF-38535, appendix A for non-JAN class level B devices and as specified herein.

3.2 Design, construction, and physical dimensions. The design, construction, and physical dimensions shall be as specified in MIL-PRF-38535 and herein for device classes Q and V or MIL-PRF-38535, appendix A and herein for device class M.

3.2.1 Case outline(s). The case outline(s) shall be in accordance with 1.2.4 herein.

3.2.2 Terminal connections. The terminal connections shall be as specified on figure 1.

3.2.3 Radiation exposure circuit. The radiation exposure circuit shall be as specified on figure 2.

3.3 Electrical performance characteristics and post irradiation parameter limits. Unless otherwise specified herein, the electrical performance characteristics and post irradiation parameter limits are as specified in table I and shall apply over the full ambient operating temperature range.

<b>STANDARD MICROCIRCUIT DRAWING</b> DEFENSE SUPPLY CENTER COLUMBUS COLUMBUS, OHIO 43216-5000	SIZE <b>A</b>		<b>85514</b>
		REVISION LEVEL <b>G</b>	SHEET <b>4</b>

TABLE I. Electrical performance characteristics.

Test	Symbol	Conditions <u>1/</u> -55°C ≤ T <sub>A</sub> ≤ +125°C unless otherwise specified	Group A subgroups	Device type	Limits		Unit
					Min	Max	
Quiescent supply current	I <sub>SY</sub>	No load	1	All		1.4	mA
			2,3			2.0	
			M,D,P,L,R <u>2/ 3/</u>	1	01		
Output adjustment <u>4/</u> range	ΔV <sub>TRIM</sub>	R <sub>P</sub> = 10 kΩ, T <sub>A</sub> = +25°C	1	All	±3.0		%
Output voltage	V <sub>O</sub>	I <sub>L</sub> = 0 mA	1	01,03	4.985	5.015	V
				02,04	4.975	5.025	
			2,3	01,03	4.978	5.022	
				02,04	4.953	5.047	
			M,D,P,L,R <u>2/ 3/</u>	1	01	4.975	
Short circuit current <u>4/</u>	I <sub>OS</sub>	V <sub>O</sub> = 0 V, T <sub>A</sub> = +25°C	1	All	+15	+60	mA
Sink current <u>4/</u>	I <sub>S</sub>	T <sub>A</sub> = +25°C	1	All	-0.3		mA
Load regulation	LD reg	I <sub>L</sub> = 0 mA to 10 mA <u>5/</u>	1	All		0.01	%mA
			M,D,P,L,R <u>2/ 3/</u>	1	01		
		I <sub>L</sub> = 0 mA to 8 mA <u>5/</u>	2,3	01,03		0.012	
				02,04		0.015	
Line regulation	LN reg	V <sub>IN</sub> = 8 V to 33 V <u>5/</u>	1	01,03		0.010	%V
				02,04		0.012	
			2,3	All		0.015	
			M,D,P,L,R <u>2/ 3/</u>	1	01		
Load current	I <sub>L</sub>	T <sub>A</sub> = +25°C <u>4/ 6/</u>	1	All	10		mA
Output voltage noise	enp-p	0.1 Hz to 10 Hz <u>4/</u>	4	01,02		18	μV <sub>P-P</sub>
				03,04		100	
Output voltage temperature coefficient	TCV <sub>O</sub>	<u>4/ 7/</u>	8	01,03		±8.5	ppm/°C
				02,04		±25	

1/ V<sub>IN</sub> = 15 V.

2/ Devices supplied to this drawing have been characterized through all levels M, D, P, L, and R of irradiation. However, this device is only tested at the "R" level. Pre and Post irradiation values are identical unless otherwise specified in table I. When performing post irradiation electrical measurements for any RHA level, T<sub>A</sub> = +25°C.

3/ These parts may be dose rate sensitive in a space environment and may demonstrate enhanced low dose rate effects. Radiation end point limits for the noted parameters are guaranteed only for the conditions specified in MIL-STD-883, method 1019, condition A.

4/ This parameter is not tested to post irradiation.

5/ Line and load regulation specifications include the effect of self heating.

6/ Minimum of 10 mA load current guaranteed by load regulation test.

7/ TCV<sub>O</sub> = (V<sub>MAX</sub> - V<sub>MIN</sub>) / 5 V × ((-55°C to +125°C) × (1 × 10<sup>6</sup>)) / 180°C.

**STANDARD  
MICROCIRCUIT DRAWING**  
DEFENSE SUPPLY CENTER COLUMBUS  
COLUMBUS, OHIO 43216-5000

SIZE  
**A**

**85514**

REVISION LEVEL  
**G**

SHEET  
**5**

Device types	01,02,03,04	01	01,02,03,04
Case outlines	G and P	H	2
Terminal number	Terminal symbol		
1	NC	NC	NC
2	V <sub>IN</sub>	V <sub>IN</sub>	NC
3	TEMP	TEMP	NC
4	GND	GND	NC
5	TRIM	TRIM	V <sub>IN</sub>
6	V <sub>OUT</sub>	V <sub>OUT</sub>	NC
7	NC	NC	TEMP
8	NC	NC	NC
9	---	NC	NC
10	---	NC	GND
11	---	---	NC
12	---	---	TRIM
13	---	---	NC
14	---	---	NC
15	---	---	V <sub>OUT</sub>
16	---	---	NC
17	---	---	NC
18	---	---	NC
19	---	---	NC
20	---	---	NC

NC = No connection

FIGURE 1. Terminal connections.

<b>STANDARD MICROCIRCUIT DRAWING</b> DEFENSE SUPPLY CENTER COLUMBUS COLUMBUS, OHIO 43216-5000	SIZE <b>A</b>		<b>85514</b>
		REVISION LEVEL <b>G</b>	SHEET <b>6</b>

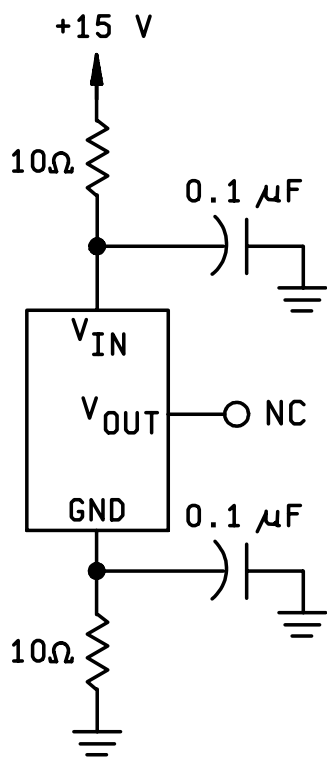

FIGURE 2. Radiation exposure circuit.

<b>STANDARD MICROCIRCUIT DRAWING</b> DEFENSE SUPPLY CENTER COLUMBUS COLUMBUS, OHIO 43216-5000	SIZE <b>A</b>		<b>85514</b>
		REVISION LEVEL <b>G</b>	SHEET <b>7</b>

3.4 Electrical test requirements. The electrical test requirements shall be the subgroups specified in table IIA. The electrical tests for each subgroup are defined in table I.

3.5 Marking. The part shall be marked with the PIN listed in 1.2 herein. In addition, the manufacturer's PIN may also be marked as listed in MIL-HDBK-103. For packages where marking of the entire SMD PIN number is not feasible due to space limitations, the manufacturer has the option of not marking the "5962-" on the device. For RHA product using this option, the RHA designator shall still be marked. Marking for device classes Q and V shall be in accordance with MIL-PRF-38535. Marking for device class M shall be in accordance with MIL-PRF-38535, appendix A.

3.5.1 Certification/compliance mark. The certification mark for device classes Q and V shall be a "QML" or "Q" as required in MIL-PRF-38535. The compliance mark for device class M shall be a "C" as required in MIL-PRF-38535, appendix A.

3.6 Certificate of compliance. For device classes Q and V, a certificate of compliance shall be required from a QML-38535 listed manufacturer in order to supply to the requirements of this drawing (see 6.6.1 herein). For device class M, a certificate of compliance shall be required from a manufacturer in order to be listed as an approved source of supply in MIL-HDBK-103 (see 6.6.2 herein). The certificate of compliance submitted to DSCC-VA prior to listing as an approved source of supply for this drawing shall affirm that the manufacturer's product meets, for device classes Q and V, the requirements of MIL-PRF-38535 and herein or for device class M, the requirements of MIL-PRF-38535, appendix A and herein.

3.7 Certificate of conformance. A certificate of conformance as required for device classes Q and V in MIL-PRF-38535 or for device class M in MIL-PRF-38535, appendix A shall be provided with each lot of microcircuits delivered to this drawing.

3.8 Notification of change for device class M. For device class M, notification to DSCC-VA of change of product (see 6.2 herein) involving devices acquired to this drawing is required for any change as defined in MIL-PRF-38535, appendix A.

3.9 Verification and review for device class M. For device class M, DSCC, DSCC's agent, and the acquiring activity retain the option to review the manufacturer's facility and applicable required documentation. Offshore documentation shall be made available onshore at the option of the reviewer.

3.10 Microcircuit group assignment for device class M. Device class M devices covered by this drawing shall be in microcircuit group number 59 (see MIL-PRF-38535, appendix A).

#### 4. QUALITY ASSURANCE PROVISIONS

4.1 Sampling and inspection. For device classes Q and V, sampling and inspection procedures shall be in accordance with MIL-PRF-38535 or as modified in the device manufacturer's Quality Management (QM) plan. The modification in the QM plan shall not affect the form, fit, or function as described herein. For device class M, sampling and inspection procedures shall be in accordance with MIL-PRF-38535, appendix A.

4.2 Screening. For device classes Q and V, screening shall be in accordance with MIL-PRF-38535, and shall be conducted on all devices prior to qualification and technology conformance inspection. For device class M, screening shall be in accordance with method 5004 of MIL-STD-883, and shall be conducted on all devices prior to quality conformance inspection.

##### 4.2.1 Additional criteria for device class M.

- a. Burn-in test, method 1015 of MIL-STD-883.
  - (1) Test condition B or D. The test circuit shall be maintained by the manufacturer under document revision level control and shall be made available to the preparing or acquiring activity upon request. The test circuit shall specify the inputs, outputs, biases, and power dissipation, as applicable, in accordance with the intent specified in test method 1015.
  - (2) T<sub>A</sub> = +125°C, minimum.
- b. Interim and final electrical test parameters shall be as specified in table IIA herein.

<b>STANDARD MICROCIRCUIT DRAWING</b> DEFENSE SUPPLY CENTER COLUMBUS COLUMBUS, OHIO 43216-5000	SIZE <b>A</b>		<b>85514</b>
		REVISION LEVEL <b>G</b>	SHEET <b>8</b>



TABLE IIA. Electrical test requirements.

Test requirements	Subgroups (in accordance with MIL-STD-883, method 5005, table I)	Subgroups (in accordance with MIL-PRF-38535, table III)	
	Device class M	Device class Q	Device class V
Interim electrical parameters (see 4.2)	---	---	---
Final electrical parameters (see 4.2)	1,2,3,4 <u>1/</u>	1,2,3,4 <u>1/</u>	1,2,3,4 <u>1/ 2/</u>
Group A test requirements (see 4.4)	1,2,3,8	1,2,3,8	1,2,3,8
Group C end-point electrical parameters (see 4.4)	1,2,3	1,2,3	1,2,3 <u>2/</u>
Group D end-point electrical parameters (see 4.4)	1,2,3	1,2,3	1,2,3
Group E end-point electrical parameters (see 4.4)	---	---	1

1/ PDA applies to subgroup 1.

2/ Delta limits as specified in table IIB shall be required where specified, and the delta limits shall be computed with reference to the previous interim electrical parameters.

TABLE IIB. 240 hour and 1000 hour life test deltas.

Test	Symbol	End point		Delta	Units
		Min	Max		
Output voltage	V <sub>O</sub>	4.985	5.015	±3	mV

4.2.2 Additional criteria for device classes Q and V.

- a. The burn-in test duration, test condition and test temperature, or approved alternatives shall be as specified in the device manufacturer's QM plan in accordance with MIL-PRF-38535. The burn-in test circuit shall be maintained under document revision level control of the device manufacturer's Technology Review Board (TRB) in accordance with MIL-PRF-38535 and shall be made available to the acquiring or preparing activity upon request. The test circuit shall specify the inputs, outputs, biases, and power dissipation, as applicable, in accordance with the intent specified in test method 1015 of MIL-STD-883.
- b. Interim and final electrical test parameters shall be as specified in table IIA herein.
- c. Additional screening for device class V beyond the requirements of device class Q shall be as specified in MIL-PRF-38535, appendix B.

<b>STANDARD MICROCIRCUIT DRAWING</b> DEFENSE SUPPLY CENTER COLUMBUS COLUMBUS, OHIO 43216-5000	SIZE <b>A</b>		<b>85514</b>
		REVISION LEVEL <b>G</b>	SHEET <b>9</b>

4.3 Qualification inspection for device classes Q and V. Qualification inspection for device classes Q and V shall be in accordance with MIL-PRF-38535. Inspections to be performed shall be those specified in MIL-PRF-38535 and herein for groups A, B, C, D, and E inspections (see 4.4.1 through 4.4.4).

4.4 Conformance inspection. Technology conformance inspection for classes Q and V shall be in accordance with MIL-PRF-38535 including groups A, B, C, D, and E inspections and as specified herein. Quality conformance inspection for device class M shall be in accordance with MIL-PRF-38535, appendix A and as specified herein. Inspections to be performed for device class M shall be those specified in method 5005 of MIL-STD-883 and herein for groups A, B, C, D, and E inspections (see 4.4.1 through 4.4.4).

4.4.1 Group A inspection.

- a. Tests shall be as specified in table IIA herein.
- b. Subgroups 5, 6, 7, 9, 10, and 11 in table I, method 5005 of MIL-STD-883 shall be omitted.

4.4.2 Group C inspection. The group C inspection end-point electrical parameters shall be as specified in table IIA herein.

4.4.2.1 Additional criteria for device class M. Steady-state life test conditions, method 1005 of MIL-STD-883:

- a. Test condition B or D. The test circuit shall be maintained by the manufacturer under document revision level control and shall be made available to the preparing or acquiring activity upon request. The test circuit shall specify the inputs, outputs, biases, and power dissipation, as applicable, in accordance with the intent specified in test method 1005 of MIL-STD-883.
- b.  $T_A = +125^{\circ}\text{C}$ , minimum.
- c. Test duration: 1,000 hours, except as permitted by method 1005 of MIL-STD-883.

4.4.2.2 Additional criteria for device classes Q and V. The steady-state life test duration, test condition and test temperature, or approved alternatives shall be as specified in the device manufacturer's QM plan in accordance with MIL-PRF-38535. The test circuit shall be maintained under document revision level control by the device manufacturer's TRB in accordance with MIL-PRF-38535 and shall be made available to the acquiring or preparing activity upon request. The test circuit shall specify the inputs, outputs, biases, and power dissipation, as applicable, in accordance with the intent specified in test method 1005 of MIL-STD-883.

4.4.3 Group D inspection. The group D inspection end-point electrical parameters shall be as specified in table IIA herein.

4.4.4 Group E inspection. Group E inspection is required only for parts intended to be marked as radiation hardness assured (see 3.5 herein). RHA levels for device classes M, Q, and V shall be as specified in MIL-PRF-38535. End-point electrical parameters shall be as specified in table IIA herein.

4.4.4.1 Total dose irradiation testing. Total dose irradiation testing shall be performed in accordance with MIL-STD-883 method 1019, condition A and as specified herein.

4.4.4.1.1 Accelerated aging test. Accelerated aging tests shall be performed on all devices requiring a RHA level greater than 5k rads(Si). The post-anneal end-point electrical parameter limits shall be as specified in table I herein and shall be the pre-irradiation end-point electrical parameter limit at  $25^{\circ}\text{C} \pm 5^{\circ}\text{C}$ . Testing shall be performed at initial qualification and after any design or process changes which may affect the RHA response of the device.

4.4.4.2 Dose rate burnout. When required by the customer test shall be performed on devices, SEC, or approved test structures at technology qualifications and after any design or process changes which may effect the RHA capability of the process. Dose rate burnout shall be performed in accordance with test method 1023 of MIL-STD-883 and as specified herein.

<b>STANDARD MICROCIRCUIT DRAWING</b> DEFENSE SUPPLY CENTER COLUMBUS COLUMBUS, OHIO 43216-5000	SIZE <b>A</b>		<b>85514</b>
		REVISION LEVEL <b>G</b>	SHEET <b>10</b>

5. PACKAGING

5.1 Packaging requirements. The requirements for packaging shall be in accordance with MIL-PRF-38535 for device classes Q and V or MIL-PRF-38535, appendix A for device class M.

6. NOTES

6.1 Intended use. Microcircuits conforming to this drawing are intended for use for Government microcircuit applications (original equipment), design applications, and logistics purposes.

6.1.1 Replaceability. Microcircuits covered by this drawing will replace the same generic device covered by a contractor-prepared specification or drawing.

6.2 Configuration control of SMD's. All proposed changes to existing SMD's will be coordinated with the users of record for the individual documents. This coordination will be accomplished using DD Form 1692, Engineering Change Proposal.

6.3 Record of users. Military and industrial users should inform Defense Supply Center Columbus when a system application requires configuration control and which SMD's are applicable to that system. DSCC will maintain a record of users and this list will be used for coordination and distribution of changes to the drawings. Users of drawings covering microelectronic devices (FSC 5962) should contact DSCC-VA, telephone (614) 692-0544.

6.4 Comments. Comments on this drawing should be directed to DSCC-VA, Columbus, Ohio 43216-5000, or telephone (614) 692-0674.

6.5 Abbreviations, symbols, and definitions. The abbreviations, symbols, and definitions used herein are defined in MIL-PRF-38535 and MIL-HDBK-1331.

6.6 Sources of supply.

6.6.1 Sources of supply for device classes Q and V. Sources of supply for device classes Q and V are listed in QML-38535. The vendors listed in QML-38535 have submitted a certificate of compliance (see 3.6 herein) to DSCC-VA and have agreed to this drawing.

6.6.2 Approved sources of supply for device class M. Approved sources of supply for class M are listed in MIL-HDBK-103. The vendors listed in MIL-HDBK-103 have agreed to this drawing and a certificate of compliance (see 3.6 herein) has been submitted to and accepted by DSCC-VA.

<b>STANDARD MICROCIRCUIT DRAWING</b> DEFENSE SUPPLY CENTER COLUMBUS COLUMBUS, OHIO 43216-5000	SIZE <b>A</b>		<b>85514</b>
		REVISION LEVEL <b>G</b>	SHEET <b>11</b>

STANDARD MICROCIRCUIT DRAWING BULLETIN

DATE: 01-02-07

Approved sources of supply for SMD 85514 are listed below for immediate acquisition information only and shall be added to MIL-HDBK-103 and QML-38535 during the next revision. MIL-HDBK-103 and QML-38535 will be revised to include the addition or deletion of sources. The vendors listed below have agreed to this drawing and a certificate of compliance has been submitted to and accepted by DSCC-VA. This bulletin is superseded by the next dated revision of MIL-HDBK-103 and QML-38535.

Standard microcircuit drawing PIN <u>1</u> /	Vendor CAGE number	Vendor similar PIN <u>2</u> /
8551401GA	24355	REF02AJ/883
	64155 <u>3</u> /	REF-02AH/883
8551401GC	<u>4</u> /	REF02AJ/883B
8551401PA	24355	REF02AZ/883
	64155 <u>3</u> /	REF-02AJ8/883
	<u>4</u> /	REF02AZ/883B
85514012A	24355	REF-02ARC/883
8551402GC	<u>4</u> /	REF02J/883B
8551402PA	<u>4</u> /	REF02Z/883B
85514022C	<u>4</u> /	REF02RC/883B
5962-8551401VGA	24355	REF02AJ/QMLV
5962-8551401VHA	24355	REF02AL/QMLV
5962-8551401VPA	24355	REF02AZ/QMLV
5962-8551401V2A	24355	REF02ARC/QMLV
5962R8551401VGA	24355	REF02AJ/QMLR
5962R8551401VHA	24355	REF02AL/QMLR
5962R8551401VPA	24355	REF02AZ/QMLR
5962R8551401V2A	24355	REF02ARC/QMLR
8551403GC	1ES66	REF02AJ/883B
8551403PA	1ES66	REF02AZ/883B

STANDARD MICROCIRCUIT DRAWING BULLETIN - CONTINUED

Standard microcircuit drawing PIN <u>1/</u>	Vendor CAGE number	Vendor similar PIN <u>2/</u>
8551404GC	1ES66	REF02J/883B
8551404PA	1ES66	REF02Z/883B
85514042C	1ES66	REF02RC/883B

- 1/ The lead finish shown for each PIN representing a hermetic package is the most readily available from the manufacturer listed for that part. If the desired lead finish is not listed contact the vendor to determine its availability.
- 2/ Caution. Do not use this number for item acquisition. Items acquired to this number may not satisfy the performance requirements of this drawing.
- 3/ The end-of-life date for this device is 30 March 2001.
- 4/ Not available from an approved source of supply.

Vendor CAGE number

Vendor name and address

24355

Analog Devices  
 RT 1 Industrial Park  
 P.O. Box 9106  
 Norwood, MA 02062  
 Point of contact: 1500 Space Park Drive  
 P.O. Box 58020  
 Santa Clara, CA 95050-8020

64155

Linear Technology Corporation  
 720 Sycamore Drive  
 Milpitas, CA 95035-7487

1ES66

Maxim Integrated Products  
 120 San Gabriel Drive  
 Sunnyvale, CA 94086-5126

The information contained herein is disseminated for convenience only and the Government assumes no liability whatsoever for any inaccuracies in the information bulletin.