

STEPPING MOTORS TYPE 86BHH150-600-40Mp

SPECIFICATIONS				WIRING DIAGRAM	
STEP ANGLE	1.8°±5%	VOLTAGE	1.8V		
NO. of PHASE	2	CURRENT/PHASE	6.0 A		
Inultion Resistant	100MΩ<500VDC>	INDUCTANCE/PHASE	3.0mh		
Ambient Temperature	-25~40℃	RESISTANCE/PHASE	0.3Ω		
Operate_Temperature	120℃ Max	HOLDING_TORQUE	86kg.cm		
Motor Weight	5.5kg Max				
Cable Weight	0.5kg Max				

FIGURE UNIT:mm

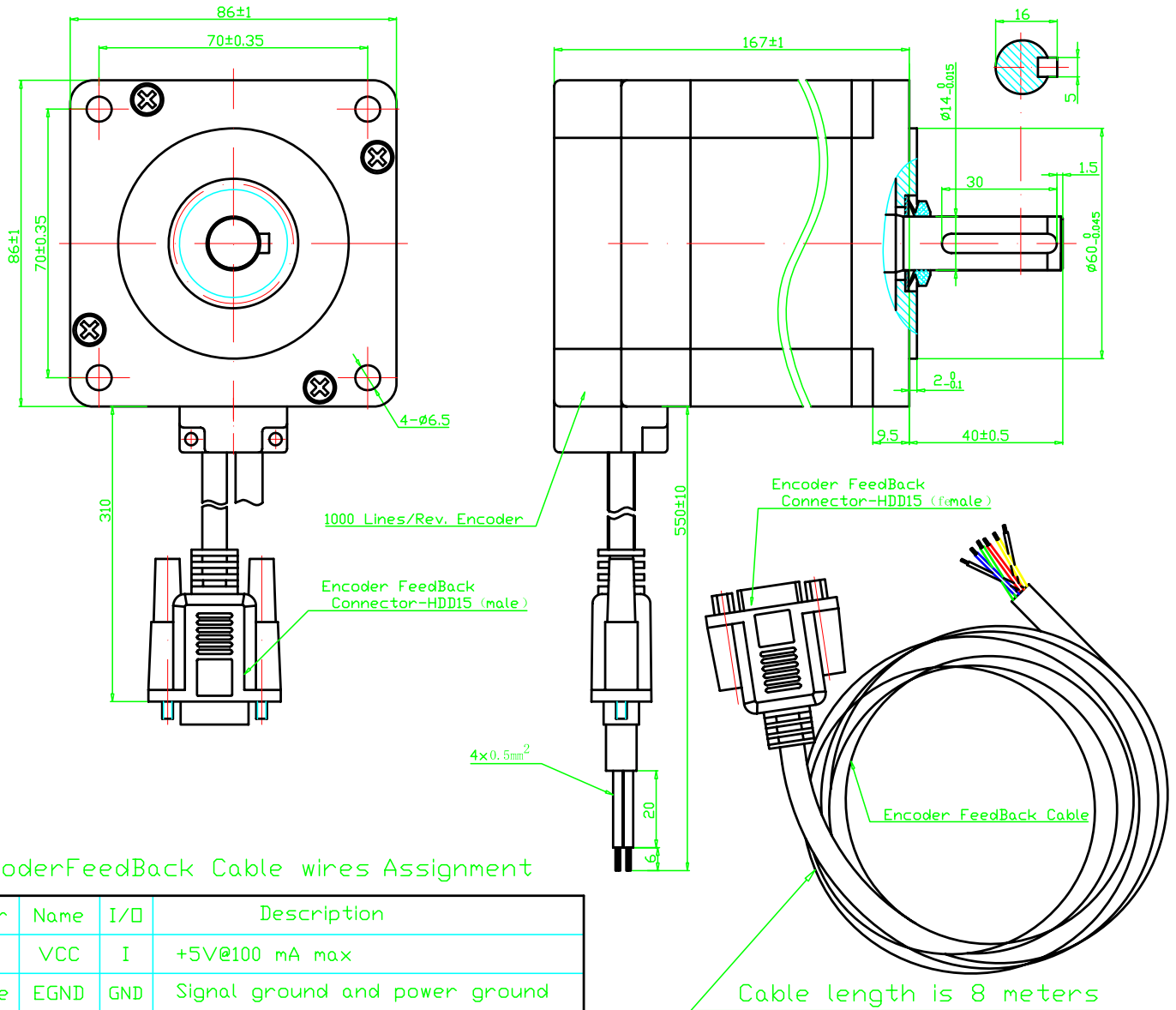

EncoderFeedBack Cable wires Assignment

Color	Name	I/O	Description
Red	VCC	I	+5V@100 mA max
White	EGND	GND	Signal ground and power ground
Blue	EA-	□	Encoder channel A- output
Black	EA+	□	Encoder channel A+ output
Green	EB-	□	Encoder channel B- output
Yellow	EB+	□	Encoder channel B+ output