

Features

- PT8A977P/977W works as encoder and PT8A978P/978LW works as decoder
- Five pins for five control functions
- Operating power-supply voltage: 2.5V to 5.0V (977P, 977W, 978P), 2.0V to 5.0V (978LW)
- Auto-power-off if no press on any button in 8s or continuously press on any button over 4 minutes
- Press on any button as wake up (977P, 977W)
- Manual-power-off with OFF button
- One output pin used for external power control (977P, 977W)
- On-chip oscillator with an external resistor
- On-chip reversing amplifiers (978P, 978LW)
- Low operating current
- Few external components needed
- Package: 14-pin DIP, 14-pin SOIC, 16-pin DIP and 16-pin SOIC

Ordering Information

Part No.	Package
PT8A977P	14-pin DIP
PT8A977W	14-pin SOIC
PT8A978P	16-pin DIP
PT8A978LW	16-pin SOIC

General Description

The PT8A977P (or 977W) and PT8A978P (or 978LW) provide a complete control functions to the remote-controlled toy. The PT8A977P/977W has five input pins corresponding with the five function buttons i.e., forward, backward, rightward, leftward and turbo. The encoding circuit in the PT8A977P/977W sends digital codes to the two output pins SO and SC. The digital codes correspond to the definite function buttons or their combinations. The SO and SC outputs are used in wireless and infra-red applications respectively.

The PT8A978P (or 978LW) has five output pins corresponding with the five actions. The received signals are amplified by the three-stage amplifier, and then the appropriate amplified signals are sampled, fault-tolerantly checked and decoded to control the actions of the remote-controlled toy.

There is an internal oscillator in the PT8A977P/977W and 978P/978LW respectively. By adding an external resistor conveniently, the oscillator will be constructed. The oscillator frequency can be adjusted by the external resistor. The relative error between the frequencies of the two on-chip oscillators in the PT8A977P/977W and PT8A978P/978LW must be less than $\pm 25\%$.

The auto-power-off function is achieved by an internal counter. The PC output is used to control on/off state of the external power supply. Pressing OFF button can also shut down the power supply. Press on any function button will wake up the chip promptly.

Block Diagram

Block Diagram of 977P/977W

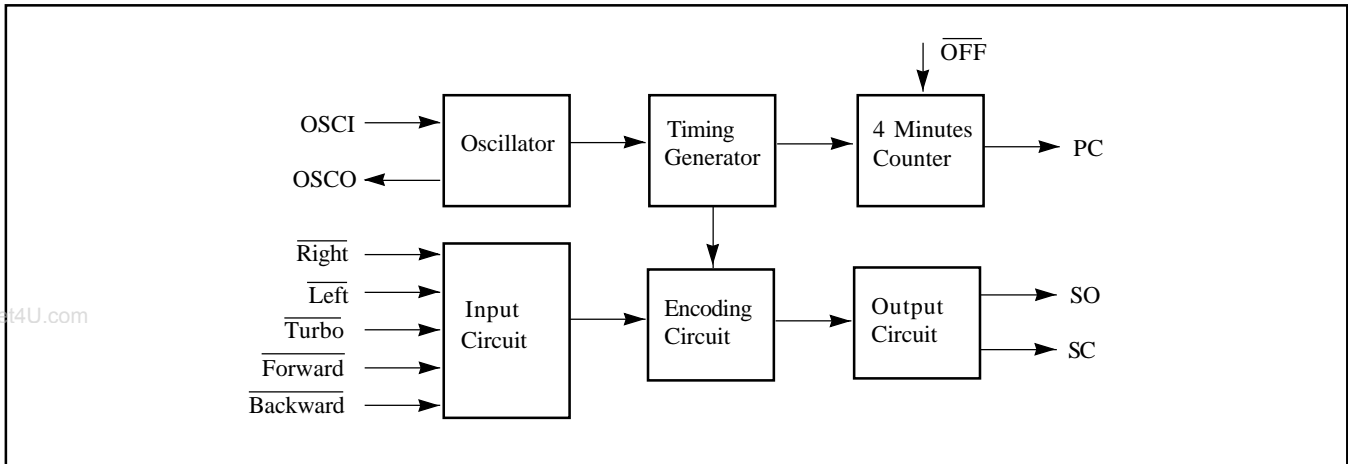

Block Diagram of 978P/978LW

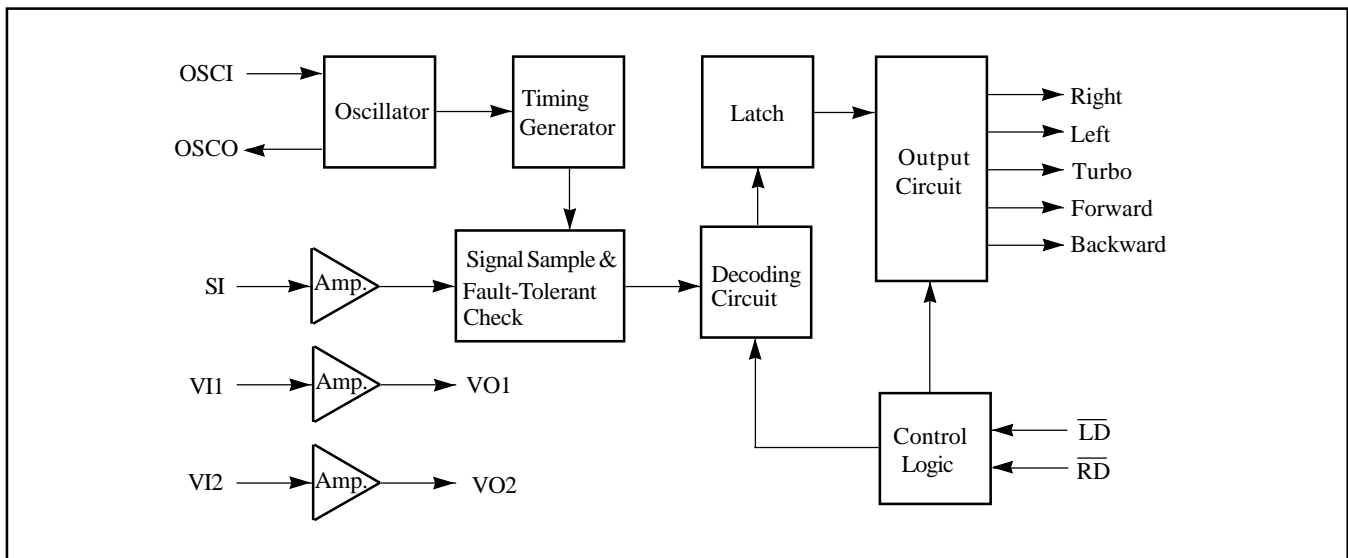

Pin Configuration

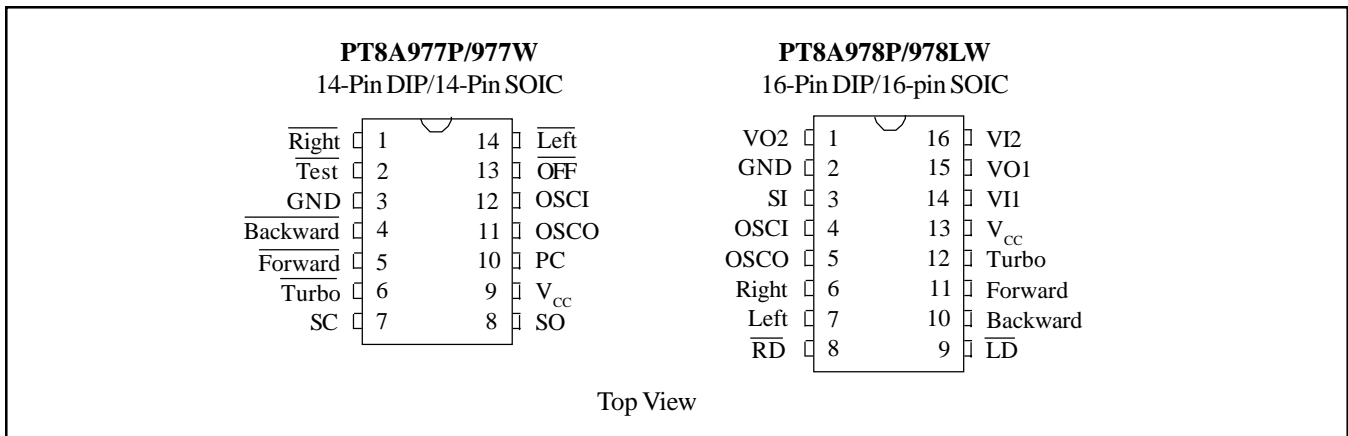

Pin Description

Pin Description of 977P/977W

Pin No.	Pin Name	Description
1	$\overline{\text{Right}}$	With Pull-up resistor, rightward function selected if this pin connected to GND.
2	$\overline{\text{Test}}$	With Pull-up resistor, this pin is used for testing mode.
3	GND	Negative power supply
4	$\overline{\text{Backward}}$	With Pull-up resistor, backward function selected if this pin connected to GND.
5	$\overline{\text{Forward}}$	With Pull-up resistor, forward function selected if this pin connected to GND.
6	$\overline{\text{Turbo}}$	With Pull-up resistor, turbo function selected if this pin connected to GND.
7	SC	Output pin of the encoding signal with carrier frequency
8	SO	Output pin of the encoding signal without carrier frequency
9	V _{cc}	Positive power supply
10	PC	Power control output pin
11	OSCO	Oscillator output pin
12	OSCI	Oscillator input pin
13	$\overline{\text{OFF}}$	With Pull-up resistor, this pin is used to shut down the external power supply.
14	$\overline{\text{Left}}$	With Pull-up resistor, leftward function selected if this pin connected to GND.

Pin Description of 978P/978LW

Pin No.	Pin Name	Description
1	VO2	Output pin for the amplifier 2
2	GND	Negative power supply
3	SI	Input pin of the encoding signal
4	OSCI	Oscillator input pin
5	OSCO	Oscillator output pin
6	Right	Rightward output pin
7	Left	Leftward output pin
8	$\overline{\text{RD}}$	With Pull-up resistor, rightward function disabled if this pin connected to GND.
9	$\overline{\text{LD}}$	With Pull-up resistor, leftward function disabled if this pin connected to GND.
10	Backward	Backward output pin
11	Forward	Forward output pin
12	Turbo	Turbo output pin
13	V _{cc}	Positive power supply
14	VI1	Input pin for the amplifier 1
15	VO1	Output pin for the amplifier 1
16	VI2	Input pin for the amplifier 2

Code Format

(W1 is used for function codes, W2 for start codes)

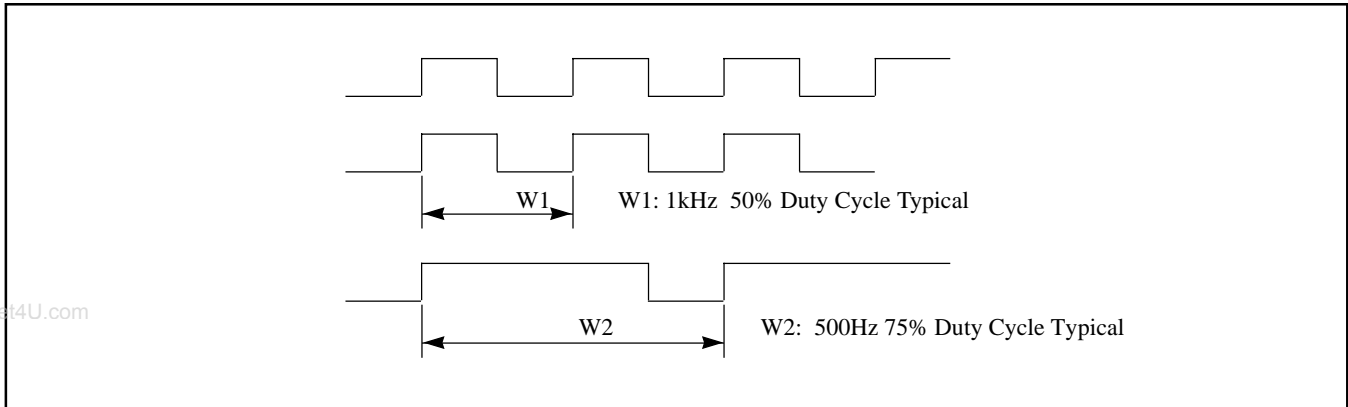

Word Format

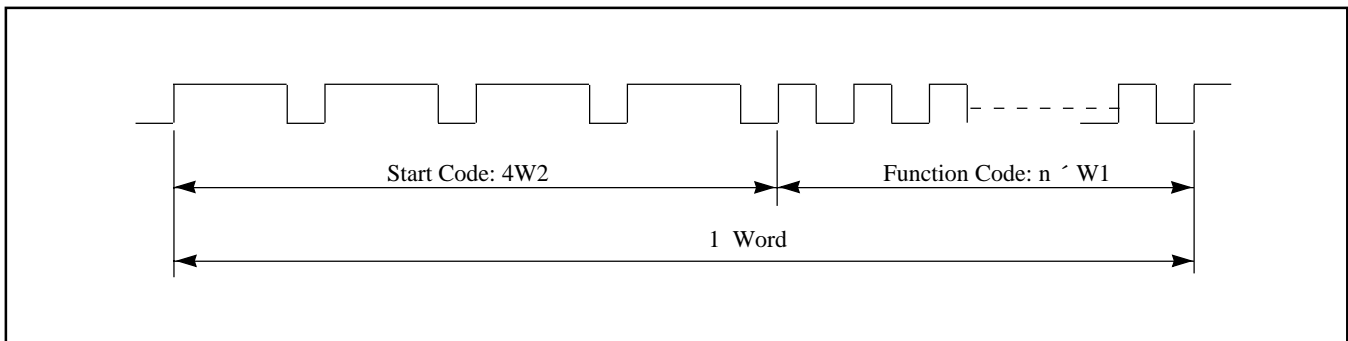

Encoding and Decoding Timing

W2, W2, W2, W2, (n)xW1, W2, W2, W2, W2, (n)xW1, W2, W2, W2, W2, (n)xW1, W2, W2, W2, W2, (n)xW1,

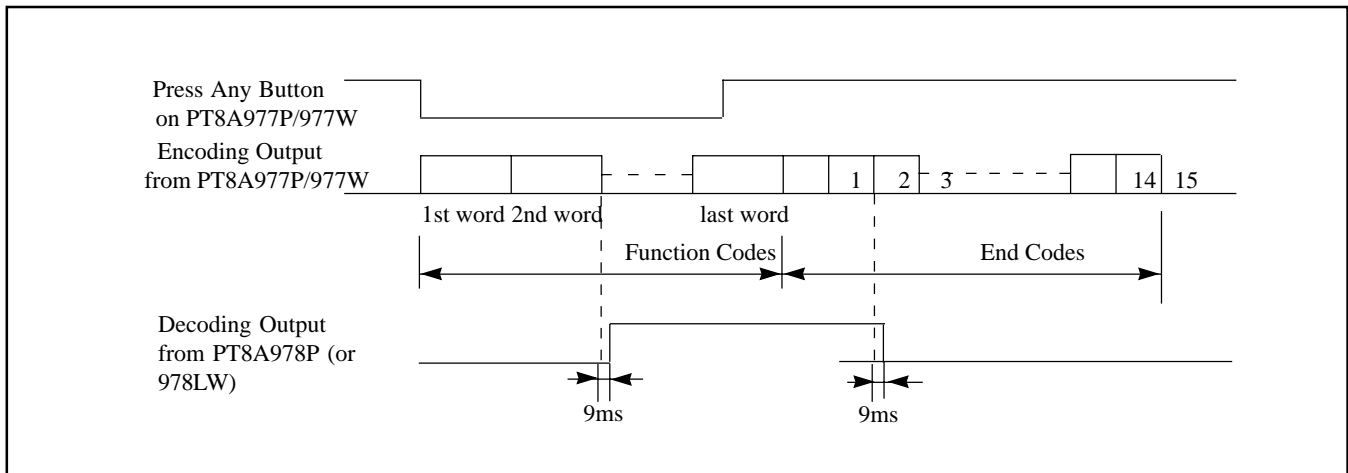

Encoding Input and Decoding Result

Number of Function Codes (n) W1	Decoding Results
4	End Code
10	Forward (Pulse)
16	Forward (High level)
22	Turbo
28	Forward (High level) & Left
34	Forward (High level) & Right
40	Backward
46	Backward & Right
52	Backward & Left
58	Left
64	Right

PC Output Timing of 977P/977W

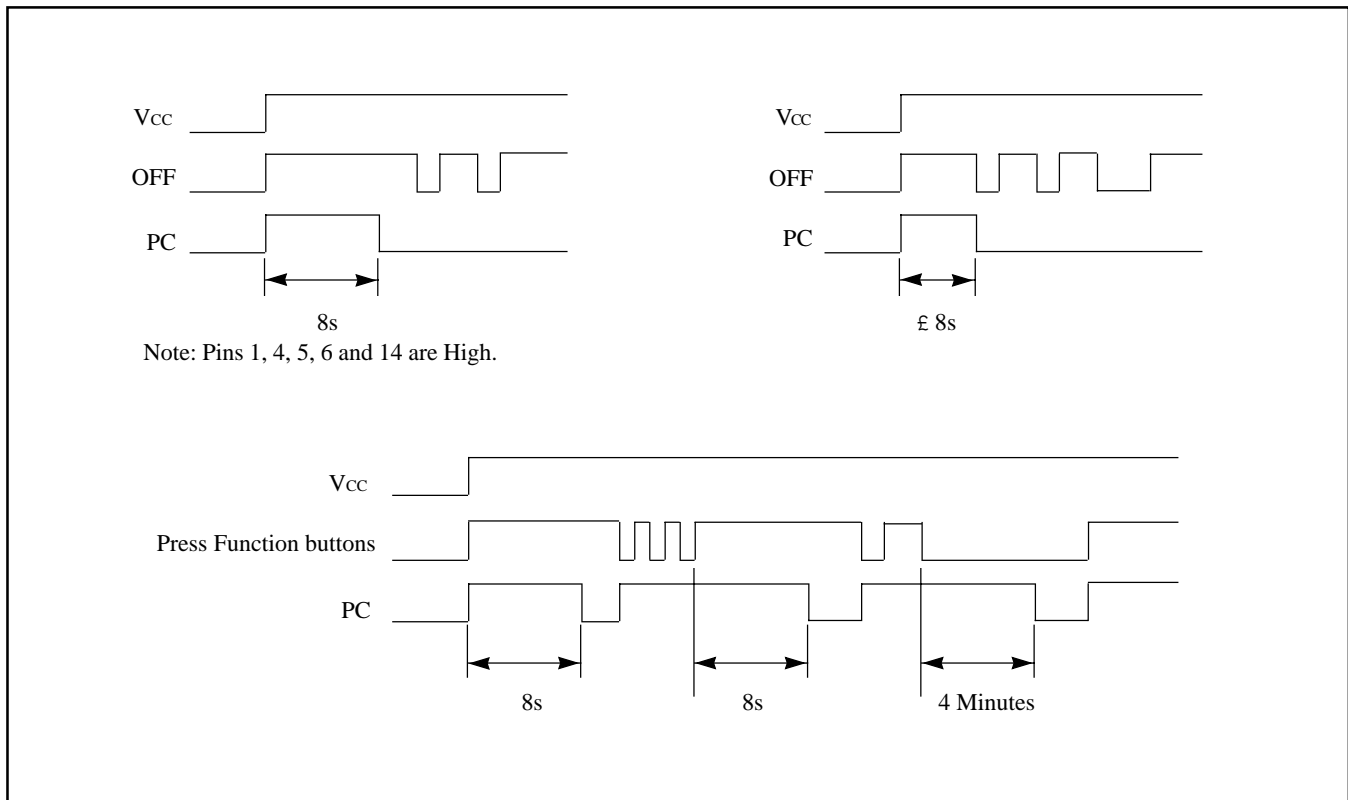

Maximum Ratings

(Above which the useful life may be impaired. For user guidelines, not tested)

Storage Temperature	-25°C to +85°C	Note: Stresses greater than those listed under MAXIMUM RATINGS may cause permanent damage to the device. This is a stress rating only and functional operation of the device at these or any other conditions above those indicated in the operational sections of this specification is not implied. Exposure to absolute maximum rating conditions for extended periods may affect reliability.
Ambient Temperature with Power Applied	-10°C to +40°C	
Supply Voltage to Ground Potential (Inputs & V _{CC} Only)	-0.5 to +6.0V	
Supply Voltage to Ground Potential (Outputs & D/O Only)	-0.5 to +6.0V	
DC Input Voltage	-0.5 to +6.0V	
DC Output Current	20mA	
Power Dissipation	500mW	

www.DataSheet4U.com

DC Electrical Characteristics

DC Electrical Characteristics of 977P/977W

Parameters	Description	Test Condition	Min.	Type	Max.	Units
V _{CC}	Operating Voltage		2.5	4.0	5.0	V
I _{CC}	Supply Current	Output unloaded			100	uA
I _{STB}	Stand-by Current	OFF State			5	uA
V _{IL}	Input Low Voltage	Guaranteed Logic LOW level			0.8	V
V _{IH}	Input High Voltage	Guaranteed Logic HIGH level	3.0			V
I _{IL}	Input Low Current	Pin 1, 4, 5, 6, 13, 14 V _{IL} = 0V, ON state			-60	uA
I _{IH}	Input High Current	Pin 1, 4, 5, 6, 13, 14 V _{IH} = 4V, ON state			10	uA
I _I	Input Current	Pin 12 V _{IH} = 0 ~ 4V, ON state			±10	uA
I _{OL}	Output Low Current	V _{OUT} = 0.5 V	150			uA
I _{OH}	Output High Current	Pin 7, 8, 10 V _{OUT} = 3.5 V	-1.0			mA
		Pin 11 V _{OUT} = 3.5 V	-200		- 800	uA

Note: Over the Operating Rating, 0°C ≤ T_A ≤ 70°C, V_{CC} = 4V

DC Electrical Characteristics of 978P/978LW

Parameters	Description	Test Condition	Min.	Type	Max.	Units
V _{CC}	Operating Voltage - 978P		2.5	4.0	5.0	V
	Operating Voltage - 978LW		2.0		5.0	V
I _{CC}	Supply Current	Output unloaded			1	mA
I _{STB}	Stand-by Current	OFF State			10	uA
V _{IL}	Input Low Voltage	Guaranteed Logic LOW level			0.8	V
V _{IH}	Input High Voltage	Guaranteed Logic HIGH level	3.0			V
I _{IL}	Input Low Current	Pin 3, 8, 9 V _{IL} = 0V, ON state			-60	uA
I _{IH}	Input High Current	Pin 3 V _{IH} = 4V, ON state			60	uA
	Input High Current	Pin 8, 9 V _{IH} = 4V, ON state			10	uA
I _I	Input Current	Pin 14, 16 V _{IH} = 0 ~ 4V, ON state			±10	uA
I _{OL}	Output Low Current	Pin 1, 5, 15 V _{OUT} = 0.5 V	200		850	uA
		Pin 6, 7, 10, 11, 12 V _{OUT} = 0.5 V	2			mA
I _{OH}	Output High Current	Pin 1, 5, 15 V _{OUT} = 3.5 V	-200		- 850	uA
		Pin 6, 7, 10, 11, 12 V _{OUT} = 3.5 V	-500			uA

Note: Over the Operating Rating, 0°C ≤ T_A ≤ 70°C, V_{CC} = 4V

AC Electrical Characteristics

AC Electrical Characteristics of 977P/977W

Parameters	Description	Test Condition	Min.	Type	Max.	Units
fosc	Oscillator Frequency *	T _A = 25°C, R = 200 kΩ	102	128	154	kHz
f _{max} - f _{min}	Oscillator Frequency Fluctuation - 977P/977W	T _A = 25°C, V _{CC} = 2.5 ~ 5V			15	kHz
t _{FUN}	Cycle Time of Function Code	fosc = 102 to 154 kHz	0.8	1	1.2	ms
t _{STA}	Cycle Time of Start Code	fosc = 102 to 154 kHz	1.6	2	2.4	ms
f _{CSC}	Carrier Frequency of SC Pin	fosc = 102 to 154 kHz	51	64	77	kHz
t _{OFF}	Time of Auto-Power-Off **	Pins 1, 4, 5, 6 and 14 are High.	64	8	9.6	s
		Any of pins 1, 4, 5, 6 or 14 is Low.	32	4	4.8	min.

Note: Over the Operating Rating, 0°C ≤ T_A ≤ 70°C, V_{CC} = 4V

* The relative error between the frequencies of the two on-chip oscillators in the PT8A977P (or 977W) and PT8A978P (or 978LW) must be less than ±25%.

** When adjust the external oscillator resistor, the auto-power-off time will vary relevantly.

AC Electrical Characteristics of 978P/978LW

Parameters	Description	Test Condition	Min.	Type	Max.	Units
fosc	Oscillator Frequency *	T _A = 25°C, R = 200 kΩ	102	128	154	kHz
f _{max} - f _{min}	Oscillator Frequency Fluctuation - 978P	T _A = 25°C, V _{CC} = 2.5 ~ 5V			15	kHz
	Oscillator Frequency Fluctuation - 978LW	T _A = 25°C, V _{CC} = 2.0 ~ 5V			10	kHz
V _{SI}	SI Pin Receive Sensitivity (V _{PP})	Guaranteed Effective Decoding	300			mV
t _{FUN}	Cycle Time of Function Code	fosc = 128 kHz	0.75	1	1.25	ms
t _{STA}	Cycle Time of Start Code	fosc = 128 kHz	1.5	2	2.5	ms

Note: Over the Operating Rating, 0°C ≤ T_A ≤ 70°C, V_{CC} = 4V

* The relative error between the frequencies of the two on-chip oscillators in the PT8A977P (or 977W) and PT8A978P (or 978LW) must be less than ±25%.

Application Circuits

Typical Application of PT8A977P/977W For Transmit Circuit With 9V Battery

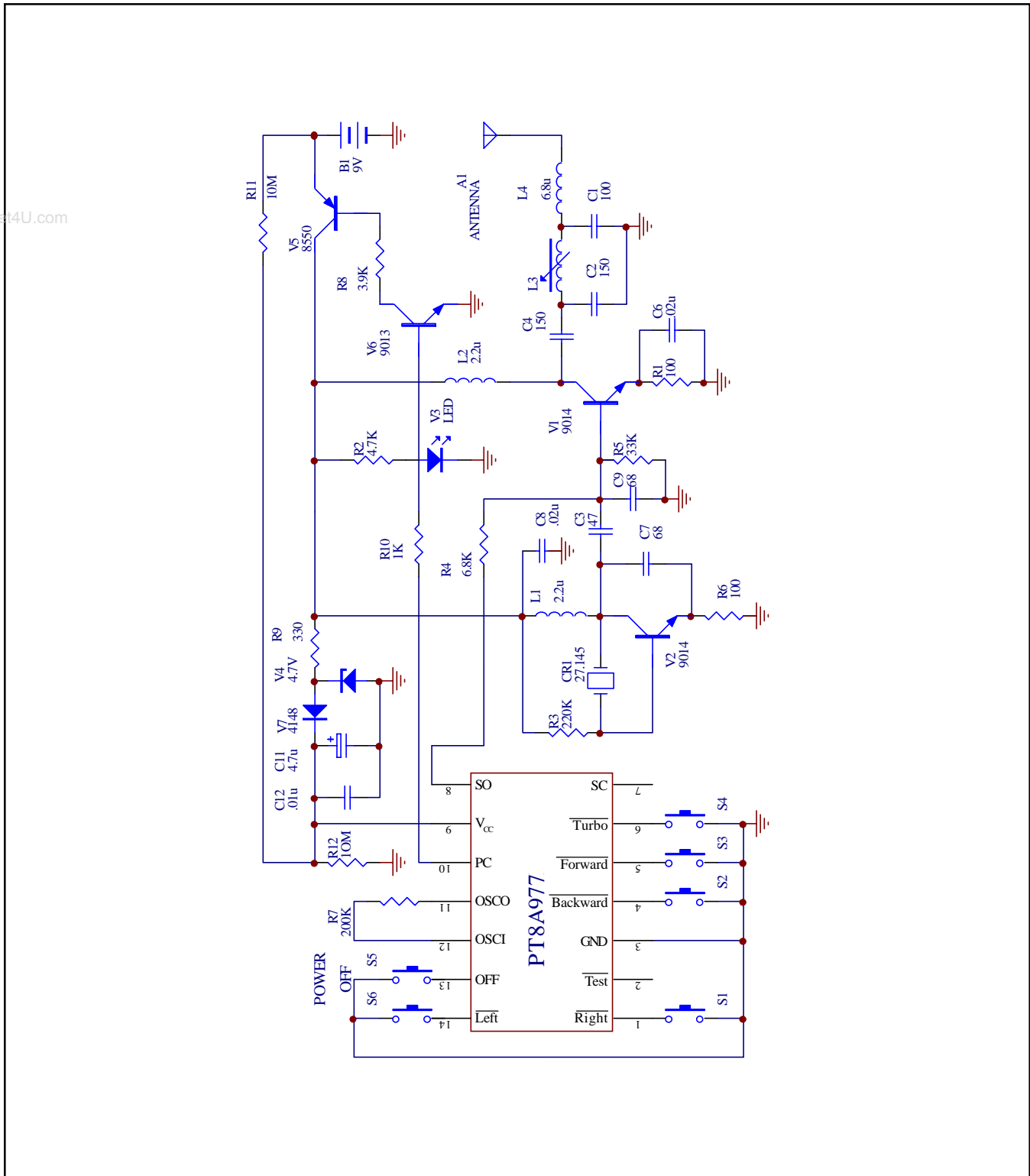

Typical Application of PT8A978P/978LW For Receive Circuit With Five Functions

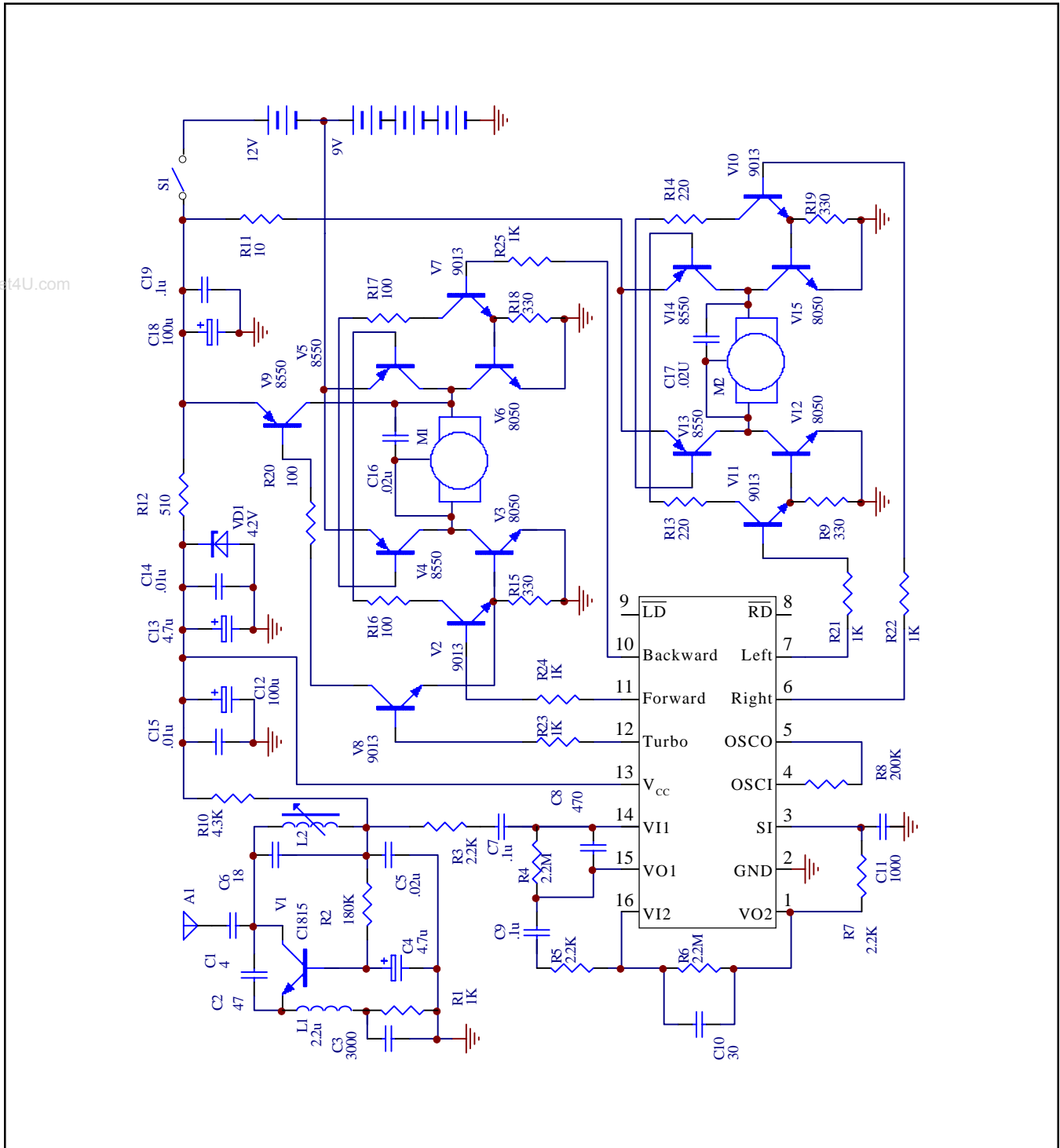

Mechanical Diagram of 14-pin SOIC

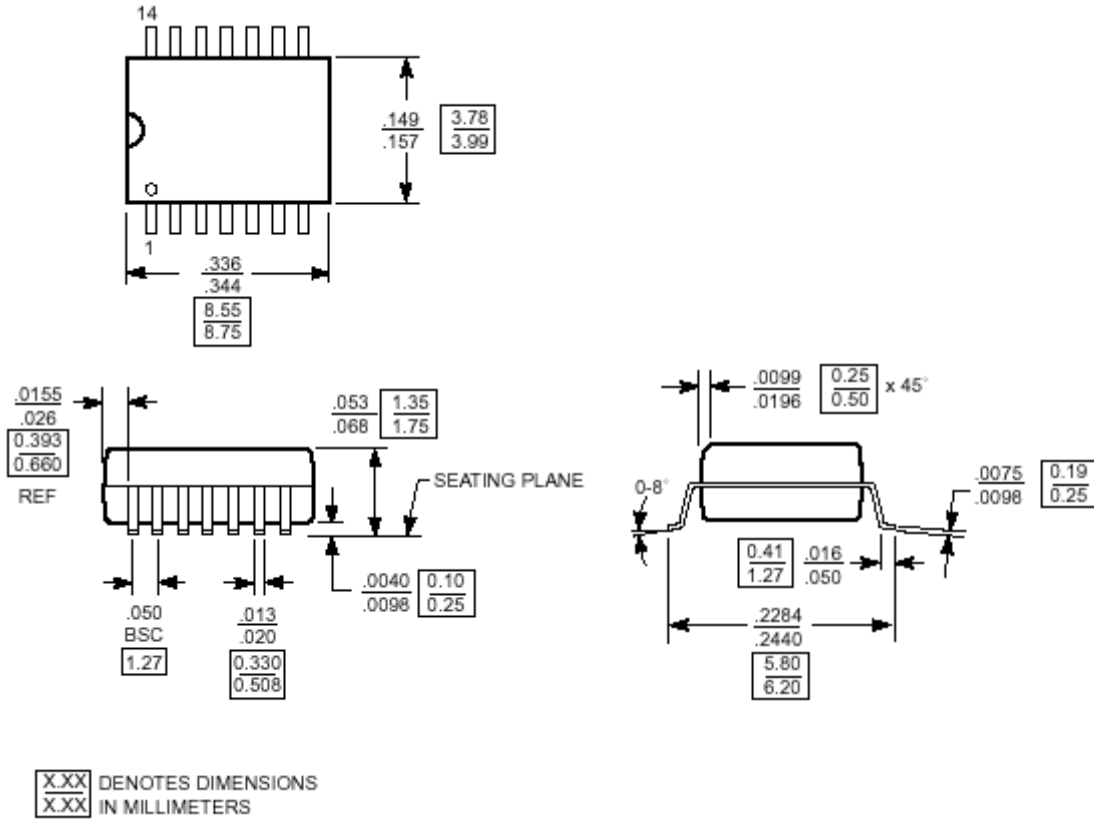

Mechanical Diagram of 16-pin SOIC

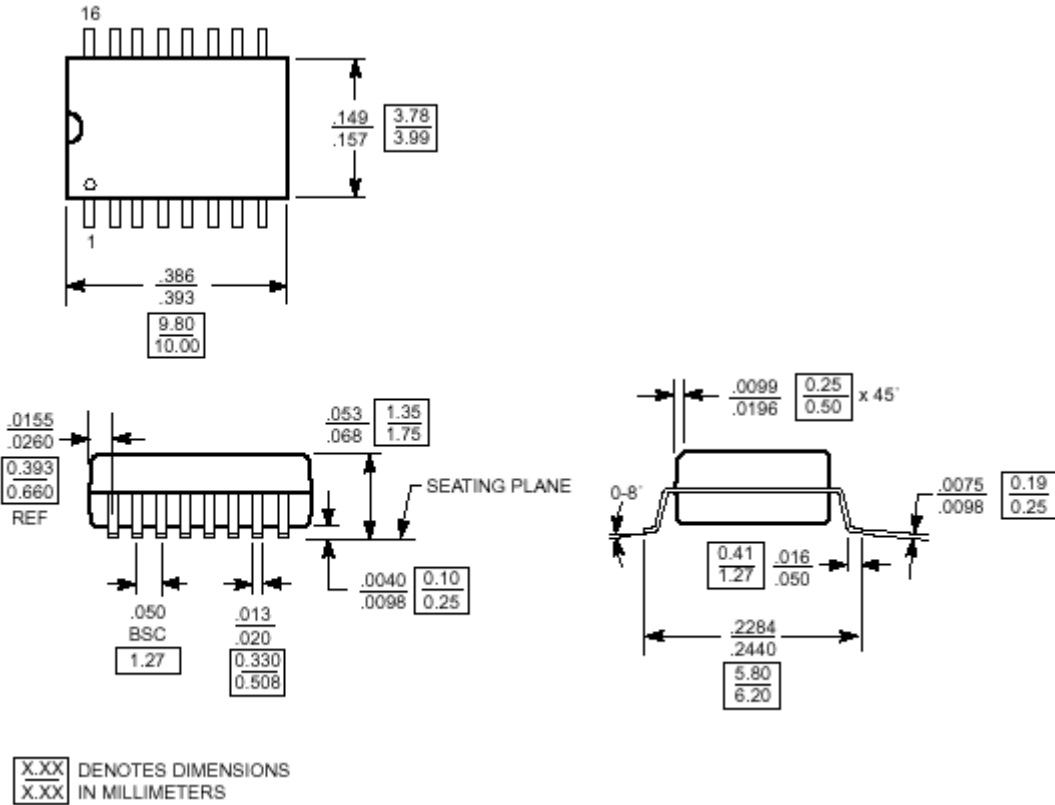

Notes

www.DataSheet4U.com

Pericom Technology Inc.

Email: support@pti.com.cn Web Site: www.pti.com.cn, www.pti-ic.com

China: No. 20 Building, 3/F, 481 Guiping Road, Shanghai, 200233, China
Tel: (86)-21-6485 0576 Fax: (86)-21-6485 2181

Asia Pacific: Unit 1517, 15/F, Chevalier Commercial Centre, 8 Wang Hoi Rd, Kowloon Bay, Hongkong
Tel: (852)-2243 3660 Fax: (852)- 2243 3667

U.S.A.: 2380 Bering Drive, San Jose, California 95131, USA
Tel: (1)-408-435 0800 Fax: (1)-408-435 1100

Pericom Technology Incorporation reserves the right to make changes to its products or specifications at any time, without notice, in order to improve design or performance and to supply the best possible product. Pericom Technology does not assume any responsibility for use of any circuitry described other than the circuitry embodied in Pericom Technology product. The company makes no representations that circuitry described herein is free from patent infringement or other rights, of Pericom Technology Incorporation.