



Document Name	Document No.	Ver	Date	Page
8LP8867220F-2 Specification	ZJQM-RD-SPC-A0774	0.0	2016/11/3	1/9

EEMB CO., LTD

Lithium Iron Phosphate Battery

Specification

Model: 8LP8867220F-2
24V
Capacity: 20Ah

Prepared	Checked	Approved

Customer :

Customer Approval (Customer confirmation) :

Customer Approval (Customer confirmation) :		
Signature	Checked	Approved

Address: Room ABCD, 25/F, Block A, Fortune Plaza, NO.7060 Shennan Road Shenzhen, China

Postal code: 518040

Phone: 0086-755-83022275

FAX: 0086-755-83021966

<http://www.eemb.com>

Document Name	Document No.	Ver	Date	Page
8LP8867220F-2 Specification	ZJQM-RD-SPC-A0774	0.0	2016/11/3	2/9

Catalog

Chapter	Content	Page
0	Catalog.....	2
1	Scope.....	3
2	Battery Cell Basic Characteristics.....	3
2.1	Model.....	3
2.2	Capacity.....	3
2.3	Nominal Voltage.....	3
2.4	Weight.....	3
2.5	Internal Impedance.....	3
2.6	Dimension.....	3
2.7	Charge.....	3
2.8	Discharge.....	3
2.9	Operation Temperature.....	3
2.10	Storage Temperature.....	3
2.11	Storage Relative Humidity.....	3
3	Battery Cell Shape and Dimensions.....	3
4	Appearance.....	4
5	Battery Cell Specification.....	4
5.1	Electrical Characteristics.....	4
5.1.1	1C ₅ A rate discharge capacity.....	4
5.1.2	High temp. discharge capacity.....	4
5.1.3	Low temp. discharge capacity.....	4
5.1.4	Cycle Life.....	4
5.1.5	Capacity Retention.....	4
5.2	Acclimatization Characteristics.....	4
5.2.1	High Temp. and High Humidity.....	4
5.2.2	Vibration.....	4
5.2.3	Drop.....	4
5.2.4	Low-pressure.....	4
5.3	Safety Characteristics.....	5
5.3.1	Overcharge.....	5
5.3.2	Short-Circuit.....	5
5.3.3	Heating.....	5
5.3.4	Temperature cycle.....	5
6	Spec of PCM.....	5-6
7	Battery Pack's Dimension.....	6
8	Battery Pack's Voltage and Internal Resistance.....	6
9	Warranty.....	6
10	Matters Needing Attention.....	6~8

Document Name	Document No.	Ver	Date	Page
8LP8867220F-2 Specification	ZJQM-RD-SPC-A0774	0.0	2016/11/3	3/9

1. Scope

This product specification defines the requirements of the rechargeable lithium iron phosphate battery supplied to the customer by EEMB Co., Ltd.

2. Battery Cell Basic Characteristics

No.	Item	Characteristics	Remark	
2.1	Model	LP8867220F		
2.2	Capacity	Nominal Capacity	10000 mAh	0.2C ₅ A
		Minimum	9500 mAh	0.2C ₅ A
2.3	Nominal Voltage	3.2 V		
2.4	Weight	Approx.250 g		
2.5	Internal Impedance	≤ 15 mΩ	AC 1KHz(50% charge)	
2.6	Dimension	Length	≤ 224 mm	
		Width	≤ 67.5 mm	
		Thickness	≤ 9.3 mm	
2.7	Charge	Maximum Current	10000 mA	1C ₅ A (CC&CV)
		Limited Voltage	3.65±0.020 V	
		End-of Current	250 mA	
2.8	Discharge	Maximum Current	20000 mA	2.0C ₅ A
		End Voltage	2.0±0.005 V	
2.9	Operation Temperature	Charge	0 ~ 45 °C	
		Discharge	-10 ~ +60 °C	
2.10	Storage Temperature	1 month	-20 ~ +60 °C	
		3 month	-20 ~ +45 °C	
		12 month	-20 ~ +25 °C	
2.11	Storage Relative Humidity	65±20 %		

3. Battery Cell Dimension

Item	Specification
T	Max9.3
W	Max67.50
L	Max224.0
L1	Max226.0
L2	10±1
M	36±1
N	20±0.5

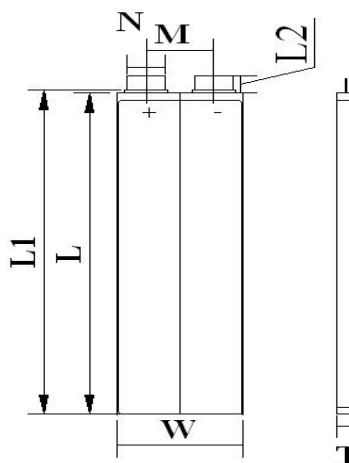

4. Appearance

It shall be free from any defects such as remarkable scratches, breaks, cracks, discoloration, leakage, or middle deformation.

5. Battery Cell Specification

5.1 Electrical Characteristics

No.	Item	Criteria	Test Instructions
5.1.1	1C ₅ A rate discharge capacity	Discharge Capacity \geq Minimum Capacity	Within 1 hour after full charge, discharge to two ends of the battery with constant current 1C ₅ A to 2.0V.
5.1.2	High temp. discharge capacity	Discharge Time \geq 54min	After full charge, store at 55 \pm 2 $^{\circ}$ C for 2h, then discharge at the same temperature with 1.0C ₅ A to 2.0V.
5.1.3	Low temp. discharge capacity	Discharge Time \geq 3h	After full charge, store at -10 $^{\circ}$ C \pm 2 $^{\circ}$ C for 16h~24h, then discharge at the same temperature with 0.2C ₅ A to 2.0V
5.1.4	Cycle Life	\geq 2000 Cycles	After full charge, rest for 10 min, then discharge at constant current 0.5C ₅ A to 2.0V, rest for 10 minutes. Repeat above steps until the two consecutive cycles of discharge time is less than 84min.
5.1.5	Capacity Retention	Discharge Time \geq 4.5 h	After full charge, store at 20 \pm 5 $^{\circ}$ C for 28 days. Then discharge with 0.2C ₅ A to 2.0V

5.2 Acclimatization Characteristics

No.	Item	Criteria	Test Instructions
5.2.1	High Temp. and High Humidity	No deformation, no rust, no fire or explosion; Discharge time \geq 36min	After full charge, store at 40 $^{\circ}$ C \pm 2 $^{\circ}$ C (90%~95%RH) for 48h. After test, place at 20 $^{\circ}$ C \pm 5 $^{\circ}$ C for 2h and then discharge with 1C ₅ A to end-voltage
5.2.2	Vibration	No damnification, leakage, no fire or explosion; Battery Voltage \geq 3.2V	Batteries are vibrated 30 min in three mutually perpendicular directions with amplitude of 0.38mm (10~30Hz) or 0.19mm (30~55Hz) and the scanning rate of 1oct per min
5.2.3	Drop	No leakage, no fire or explosion; Discharge Time \geq 51 min	Batteries are dropped onto a hard board with the thickness of 18~20mm from height of 1000mm, drop freely from each positive and negative direction (six direction) of X, Y, Z for one time, after that, discharge with 1C ₅ A to end-voltage
5.2.4	Low-pressure	No leakage, no fire or explosion	Put the batteries in a sealed vacuum and reduce internal pressure gradually to lower than 11.6 kpa. Keep for 6h

5.3 Safety Characteristics

No.	Item	Criteria	Test Instructions
5.3.1	Overcharge	No fire or explosion	Put the batteries with thermocouple into the ventilation cabinet. Connect the polarities to constant voltage and adjust the current to 3C ₅ A, voltage to 4.8V. Charged the cells with 3C ₅ A until voltage of 4.8V and current approach 0 A.
5.3.2	Short-Circuit	No fire or explosion; The maximum Temperature: 150°C	Put the batteries with thermocouple into the ventilation cabinet. Batteries are short-circuited by connecting the positive and negative terminals with a total resistance load of 100mΩ. Watch the changes of temperature. End the test when the temperature of the batteries drops to 10°C lower than the peak value.
5.3.3	Heating	No fire or explosion	Cell is heated in a circulating air oven at a rate of (5±2)°C per minute to 130±2°C, and then placed for 30 minutes
5.3.4	Temperature cycle	No leakage, no fire or explosion	After full charge, place the battery in the temperature control box of 20±5°C, do the following steps: (1)Put the battery into test chamber of 75°C±2°C and keep for 6h. (2)Lower the temperature to -40±2°C and keep for 6h (3)Temperature conversion time is no longer than 30 min (4)Repeat the above three steps for 10 cycles.

Note: Unless otherwise specified, all tests stated in this specification are conducted at the following conditions: Temp. : 20±5°C; Relative Humidity: 25%~85%.

6. Specification of PCM

The specification shall be applied to Lithium polymer battery protection circuit module manufactured by EEMB CO., LTD.

6.1 Basic Specification(T=25°C)

Item	Symbol	Content	Criterion
Over charge Protection	V _{DET1}	Over charge detection voltage	3.65±0.05V/Cell
	tV _{DET1}	Over charge detection delay time	0.5S-1.40S
	V _{REL1}	Over charge release voltage	3.45±0.1V/Cell
Over discharge protection	V _{DET2}	Over discharge detection voltage	2.5±0.1V/Cell
	tV _{DET2}	Over discharge detection delay time	50ms-200ms
	V _{REL2}	Over discharge release voltage	3.0±0.1V/Cell
	I _{DP}	Over current detection current	>30A
Short protection		Detection condition	Exterior short circuit
		Release condition	Cut short circuit
Interior resistance	R _{DS}	Main loop electrify resistance	R _{DS} ≤70mΩ
Current consumption	I _{DD}	Current consume in normal operation	20μA Type 50μA Max

Document Name	Document No.	Ver	Date	Page
8LP8867220F-2 Specification	ZJQM-RD-SPC-A0774	0.0	2016/11/3	6/9

6.2. PCM Circuit Diagram (For reference only)

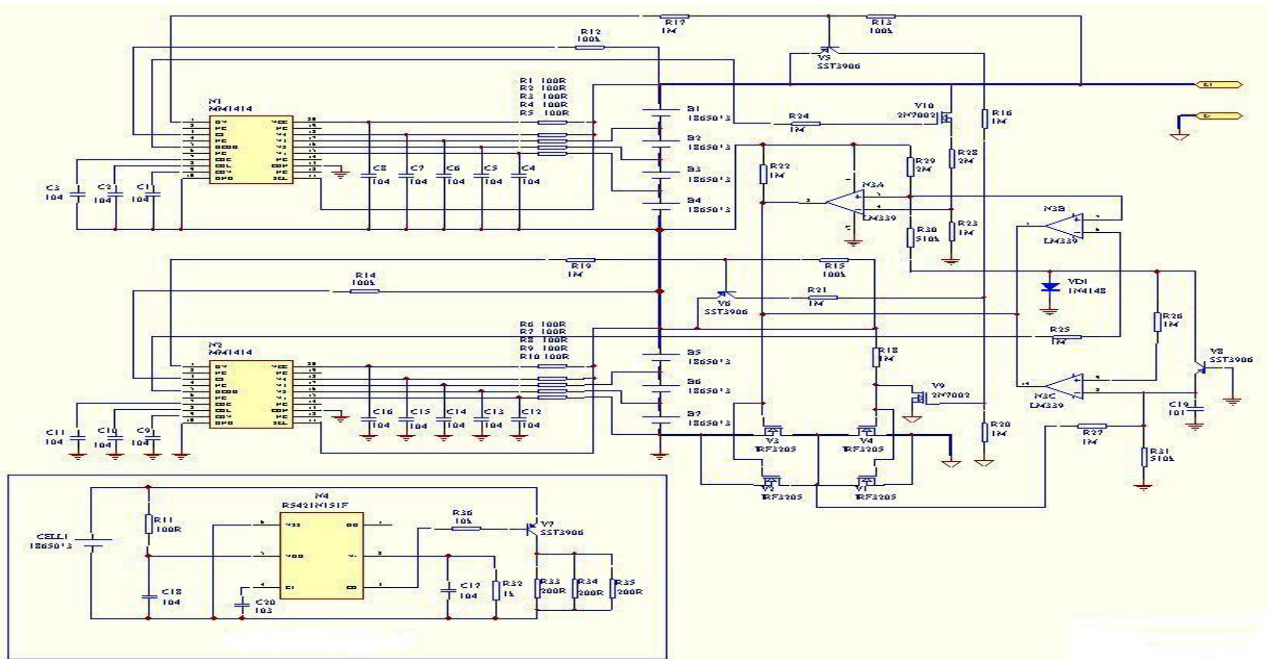

7. Battery Pack's Dimension(For reference)



Document Name	Document No.	Ver	Date	Page
8LP8867220F-2 Specification	ZJQM-RD-SPC-A0774	0.0	2016/11/3	7/9



1. Whitebait shell dimension
T (max) =170mm
W (max) =100mm
H (max) =380mm

8. Battery Pack's Voltage and Internal Resistance

Voltage: 25.6V~27.2V

Internal Resistance: $\leq 300\text{m}\Omega$

Pack overcharge protection voltage range: 28.0V-30.0V (the voltage should be monitored by test tank)

Pack overdischarge protection voltage range: 19.2V-23.2V (the voltage should be monitored by test tank)

Pack max continuous charging and discharging current: 10A

Pack max pulse current & time: 30A/1S

Pack mini. Capacity: 18.6Ah

9. Warranty

One year warranty after the date of production

10. Matters Needing Attention

Strictly observes the following needing attention. EEMB will not be responsible for any accident occurred by handling outside of the precautions in this specification.

! Danger

- Strictly prohibits heat or throw cell into fire.
- Strictly prohibits throw and wet cell in liquid such as water、 gasoline or drink etc.
- Strictly prohibits use leave cell close to fire or inside of a car where temperature may be above 60°C. Also do not charge / discharge in such conditions.
- Strictly prohibits put batteries in your pockets or a bag together with metal objects such as necklaces.

Document Name	Document No.	Ver	Date	Page
8LP8867220F-2 Specification	ZJQM-RD-SPC-A0774	0.0	2016/11/3	8/9

Hairpins, coins, or screws. Do not store or transportation batteries with such objects.

- Strictly prohibits short circuit the (+) and (-) terminals with other metals.
- Do not place Cell in a device with the (+) and (-) in the wrong way around.
- Strictly prohibits pierce Cell with a sharp object such as a needle.
- Strictly prohibits disassemble or modify the cell.
- Strictly prohibits welding a cell directly.
- Do not use a Cell with serious scar or deformation.
- Thoroughly read the user's manual before use, inaccurate handling of lithium ion rechargeable cell may cause leakage, heat, smoke, an explosion, or fire, capacity decreasing.

! Warning

- Strictly prohibits put cell into a microware oven, dryer, or high-pressure container.
- Strictly prohibits use cell with dry cells and other primary batteries, or new and old battery or batteries of a different package, type, or brand.
- Stop charging the Cell if charging is not completed within the specified time.
- Stop using the Cell if abnormal heat, odor, discoloration, deformation or abnormal condition is detected during use, charge, or storage.
- Keep away from fire immediately when leakage or foul odor is detected.
- If liquid leaks onto your skin or clothes, wash well with fresh water immediately.
- If liquid leaking from the Cell gets into your eyes, do not rub your eyes. Wash them well with clean edible oil and go to see a doctor immediately.

! Caution

- Before using the Cell, be sure to read the user's manual and cautions on handling thoroughly.
- Charging with specific charger according to product specification. Charge with CC/CV method. Strictly prohibits reversed charging. Connect cell reverse will not charge the cell. At the same time, it will reduce the charge-discharge characteristics and safety characteristics, this will lead to product heat and leakage.
- Store batteries out of reach of children so that they are not accidentally swallowed.
- If younger children use the Cell, their guardians should explain the proper handling.
- Before using the Cell, be sure to read the user's manual and cautions on handling thoroughly.
- Batteries have life cycles. If the time that the Cell powers equipment becomes much shorter than usual, the Cell life is at an end. Replace the Cell with a new same one.
- When not using Cell for an extended period, remove it from the equipment and store in a place with low humidity and low temperature.
- While the Cell pack is charged, used and stored, keep it away from objects or materials with static electric charges.
- If the terminals of the Cell become dirty, wipe with a dry clothe before using the Cell.
Storage the cells in storage temperature range as the specifications, after full discharged, we suggest that charging to 25.6V~27.2V with no using for a long time.
- Battery should be charged and discharged every 3 months at 0.2 C during long term storage, and then charge to 50-70% of the capacity for storage.
- Do not exceed these ranges of the following temperature ranges:
 - Charge temperature range : 0°C to 45°C;
 - Discharge temperature range : -10°C to 60°C.
 - Store less than 1 month : -20°C - +60°C



Document Name	Document No.	Ver	Date	Page
8LP8867220F-2 Specification	ZJQM-RD-SPC-A0774	0.0	2016/11/3	9/9

Store less than 3 months: -20°C - +45°C

Store less than 1 year : -20°C - +25°C

! Special Notice

Keep the cells in **50% charged state** during long period storage. We recommend to charge the battery up to 50% of the total capacity every 3 months after receipt of the battery and maintain the voltage 25.6V~27.2V. And store the battery in cool and dry place.