

isc N-Channel MOSFET Transistor

8N20

• DESCRIPTION

- Drain Current $I_D = 8A @ T_C = 25^\circ C$
- Drain Source Voltage-
: $V_{DSS} = 200V(\text{Min})$
- Fast Switching Speed

• APPLICATIONS

- General purpose power amplifier

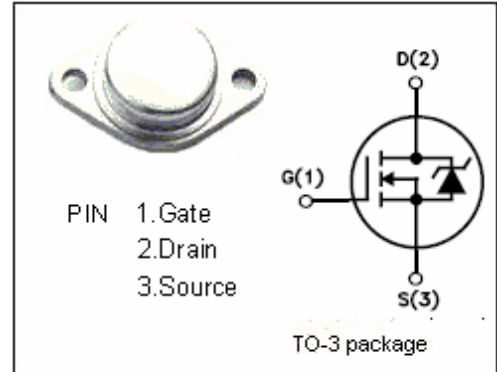

• ABSOLUTE MAXIMUM RATINGS($T_C = 25^\circ C$)

SYMBOL	PARAMETER	VALUE	UNIT
V_{DSS}	Drain-Source Voltage ($V_{GS} = 0$)	200	V
V_{GS}	Gate-Source Voltage	± 20	V
I_D	Drain Current-continuous @ $T_C = 25^\circ C$	8	A
$I_{D(puls)}$	Pulse Drain Current	20	A
P_{tot}	Total Dissipation @ $T_C = 25^\circ C$	75	W
T_j	Max. Operating Junction Temperature	150	$^\circ C$
T_{stg}	Storage Temperature Range	-55~150	$^\circ C$

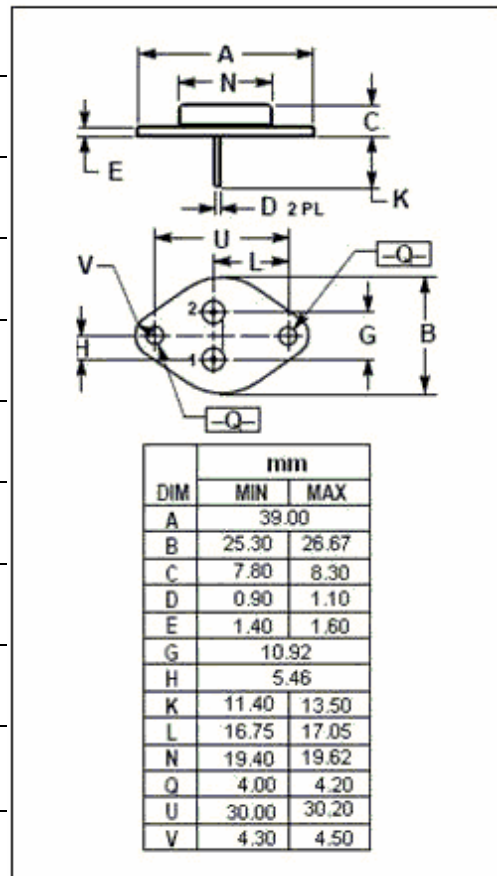

• THERMAL CHARACTERISTICS

SYMBOL	PARAMETER	MAX	UNIT
$R_{th\ j-c}$	Thermal Resistance, Junction to Case	1.67	$^\circ C/W$

isc N-Channel MOSFET Transistor

8N20

• ELECTRICAL CHARACTERISTICS ($T_C=25^\circ\text{C}$)

SYMBOL	PARAMETER	CONDITIONS	MIN	TYPE	MAX	UNIT
$V_{(BR)DSS}$	Drain-Source Breakdown Voltage	$V_{GS}=0; I_D=1\text{mA}$	200			V
$V_{GS(th)}$	Gate Threshold Voltage	$V_{DS}=V_{GS}; I_D=1\text{mA}$	2.0		4.0	V
V_{SD}	Diode Forward On-Voltage	$I_S=4\text{A}; V_{GS}=0$			1.4	V
$R_{DS(on)}$	Drain-Source On-Resistance	$V_{GS}=10\text{V}; I_D=4\text{A}$			0.5	Ω
I_{GSS}	Gate-Body Leakage Current	$V_{GS}= \pm 20\text{V}; V_{DS}=0$			± 100	nA
I_{DSS}	Zero Gate Voltage Drain Current	$V_{DS}=160\text{V}; V_{GS}=0$			1	μA
C_{iss}	Input Capacitance	$V_{DS}=25\text{V};$			750	pF
C_{rss}	Reverse Transfer Capacitance	$V_{GS}=0\text{V};$			100	
C_{oss}	Output Capacitance	$f_T=1\text{MHz}$			250	
t_r	Rise Time	$V_{GS}=10\text{V};$			150	ns
$t_{d(on)}$	Turn-on Delay Time	$I_D=4\text{A};$			40	
t_f	Fall Time	$V_{DD}=100\text{V};$			105	
$t_{d(off)}$	Turn-off Delay Time	$R_L=50\Omega$			135	