

General Description

The 8V44N4614 is a FemtoClock[®] NG Clock Generator. The device has been designed for frequency generation in high-performance systems such as wireless base-band boards, for instance to drive the reference clock inputs of processors, PHY, switch and SerDes devices. The device is very flexible in frequency programming. It allows to generate the clock frequencies of 156.25MHz, 125MHz, 100MHz and 25MHz individually at three output banks. One output bank supports configurable LVDS, LVPECL, the other two output banks support LVCMOS output levels. All outputs are synchronized on the incident rising edge, regardless of the selected output frequency. Selective single-ended LVCMOS outputs can be configured to invert the output phase, effectively forming differential LVCMOS output pairs for noise reduction. The PLL reference signal is either a 25MHz, 50MHz, 100MHz or 200MHz differential or single-ended clock.

The device is optimized to deliver excellent period and cycle-to-cycle jitter performance, combined with good phase noise performance, and high power supply noise rejection.

The device is configured through an SPI serial interface. Outputs can be configured to any of the available output frequencies. Two hardware pins are available for selecting pre-set output enable/disable configurations. In each of these pre-set configurations, each output can be enabled/disabled individually. A separate test mode is available for an increase or decrease of the output frequencies in 19.53125ppm steps independent on the input frequency. The device is packaged in a lead-free (RoHS 6) 48-lead VFQFN package. The extended temperature range supports wireless infrastructure, telecommunication and networking end equipment requirements.

Features

- Clock generator for wireless base-band systems
- Drives reference clock inputs of processors, PHY, switch and SerDes devices
- FemtoClock[®] NG technology
- Three low-skew, differential LVDS, LVPECL configurable clock outputs
- Ten low-skew, LVCMOS/LVTTL clock outputs
- Input: 200MHz, 100MHz, 50MHz, 25MHz single-ended (LVCMOS) or differential reference clock (LVDS, LVPECL)
- Output clocks support 156.25MHz, 125MHz, 100MHz and 25MHz
- Individual output disable (high-impedance)
- Two sets of output enable configurations
- PLL lock detect output
- Test mode with frequency margining with 19.53125ppm steps (range ± 507.8125 ppm)
- LVCMOS (1.8V, JESD8-7A) compatible SPI programming interface
- Cycle-to-cycle jitter: 10ps (typical)
- RMS period jitter: 1.6ps (typical)
- Phase noise (12kHz - 20MHz): 0.40ps (typical)
- 3.3V core and output supply
- -40°C to +85°C ambient operating temperature
- Lead-free (RoHS 6) 48-lead VFQFN packaging

Block Diagram

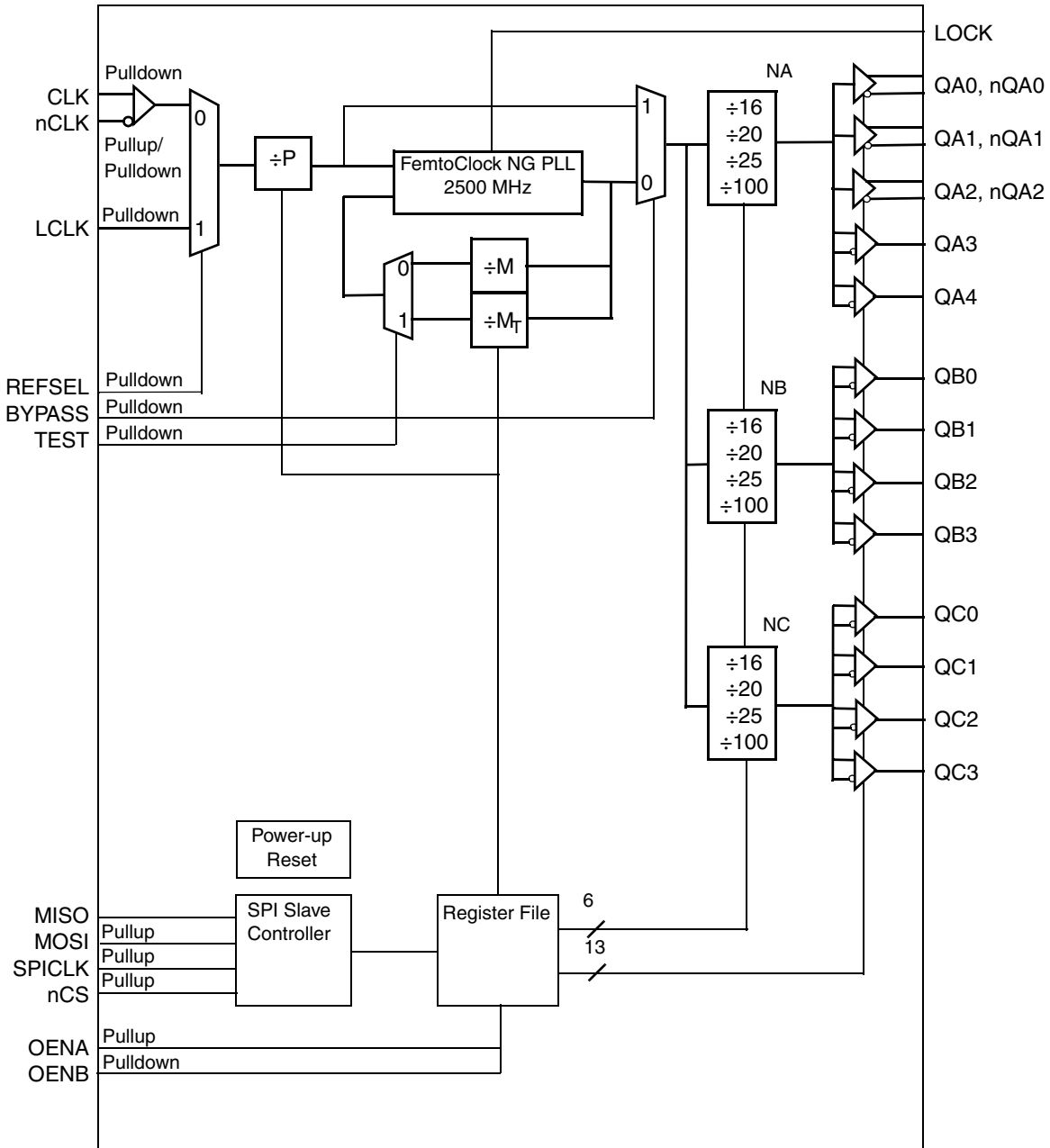

Pin Assignment

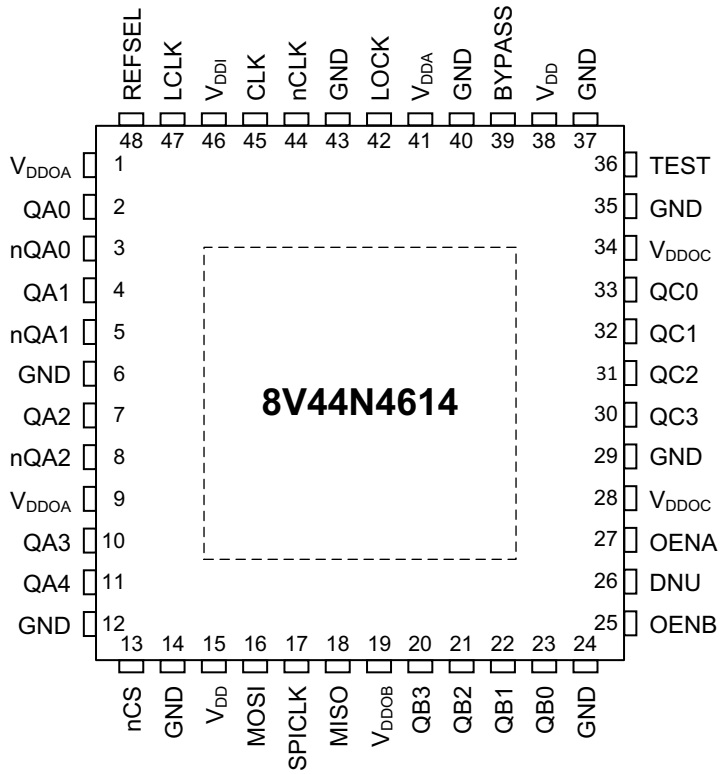

48-pin, 7mm x 7mm VFQFN Package

Table 1: Pin Descriptions

Number	Name	Type		Description
1, 9	V _{DDOA}	Power		Supply voltage for the QA bank clock outputs (3.3V).
2, 3	QA0, nQA0	Output		Differential clock output A0. LVDS or LVPECL configurable output levels.
4, 5	QA1, nQA1	Output		Differential clock output A1. LVDS or LVPECL configurable output levels.
6, 12, 14, 24, 29, 35, 37, 40, 43	GND	Power		Negative supply voltage (GND).
7, 8	QA2, nQA2	Output		Differential clock output A2. LVDS or LVPECL configurable output levels.
10	QA3	Output		Single-ended clock output A3. 3.3V LVCMOS/LVTTL output levels.
11	QA4	Output		Single-ended clock output A4. Complementary to QA3 when configured as inverted output. 3.3V LVCMOS/LVTTL output levels.
13	nCS	Input	Pullup	SPI interface chip select input. 1.8V LVCMOS (JESD8-7A) interface levels, 3.3V tolerant.
15, 38	V _{DD}	Power		Core voltage for the device core (3.3V).
16	MOSI	Input	Pullup	Serial Control Port SPI Mode Data Input. 1.8V LVCMOS (JESD8-7A) interface levels. 3.3V tolerant.
17	SPICLK	Input	Pullup	Serial Control Port SPI Mode Clock Input. 1.8V LVCMOS (JESD8-7A) interface levels. 3.3V tolerant.

Table 1: Pin Descriptions (Continued)

Number	Name	Type		Description
18	MISO	Output		Serial Control Port SPI Mode Data Output. 1.8V LVCMOS (JESD8-7A) output levels.
19	V _{DDOB}	Power		Supply voltage for the QB bank clock outputs (3.3V).
20	QB3	Output		Single-ended clock output B3. Complementary to QB2 when configured as inverted output. 3.3V LVCMOS/LVTTL output levels.
21	QB2	Output		Single-ended clock output B2. 3.3V LVCMOS/LVTTL output levels.
22	QB1	Output		Single-ended clock output B1. Complementary to QB0 when configured as inverted output. 3.3V LVCMOS/LVTTL output levels.
23	QB0	Output		Single-ended clock output B0. 3.3V LVCMOS/LVTTL output levels.
25	OENB	Input	Pulldown	Output enable (active high). 3.3V LVCMOS/LVTTL interface levels. See Table 3J for function.
26	DNU	–		Do not connect and do not use.
27	OENA	Input	Pullup	Output enable (active high). 3.3V LVCMOS/LVTTL interface levels. See Table 3J for function.
28, 34	V _{DDOC}	Power		Supply voltage for the QC bank clock outputs (3.3V)
30	QC3	Output		Single-ended clock output C3. Complementary to QC2 when configured as inverted output. 3.3V LVCMOS/LVTTL output levels.
31	QC2	Output		Single-ended clock output C2. 3.3V LVCMOS/LVTTL output levels.
32	QC1	Output		Single-ended clock output C1. Complementary to QC0 when configured as inverted output. 3.3V LVCMOS/LVTTL output levels.
33	QC0	Output		Single-ended clock output C0. 3.3V LVCMOS/LVTTL output levels.
36	TEST	Input	Pulldown	Test mode control input. Compatible with LVCMOS/LVTTL (3.3V) signals. See Table 3C for function.
39	BYPASS	Input	Pulldown	PLL Bypass control input. Compatible with LVCMOS/LVTTL (3.3V) signals. See Table 3B for function.
41	V _{DDA}	Power		Supply voltage for the internal PLL (3.3V)
42	LOCK	Output		PLL lock detect output. 3.3V LVCMOS/LVTTL output levels.
44	nCLK	Input	Pullup / Pulldown	Inverting differential clock input. Inverting input is biased to V _{DD} / 2 by default when left floating. Compatible with LVPECL and LVDS signals.
45	CLK	Input	Pulldown	Non-inverting differential input clock. Compatible with LVPECL and LVDS signals.
46	V _{DDI}	Power		Core voltage for the reference clock (input) circuits (3.3V)
47	LCLK	Input	Pulldown	Alternative clock input. Compatible with LVCMOS/LVTTL (3.3V) signals.
48	REFSEL	Input	Pulldown	PLL reference select control input. Compatible with LVCMOS/LVTTL (3.3V) signals. See Table 3A for function.
–	V _{EE_EP}	Power		Exposed pad of package. Connect to GND.

Table 2. Pin Characteristics

Symbol	Parameter	Test Conditions	Minimum	Typical	Maximum	Units
C_{IN}	Input Capacitance			4		pF
R_{PULLUP}	Input Pullup Resistor			51		k Ω
$R_{PULLDOWN}$	Input Pulldown Resistor			51		k Ω
R_{OUT}	Output Impedance	QA[3:4], QB[0:3], QC[0:3] $V_{DDOA}, V_{DDOB}, V_{DDOC} = 3.3V$		25		Ω

Functional Description

Function Tables

Table 3A. PLL Reference Signal Select¹

Input	Operation
REFSEL	Operation
0 (default)	The differential CLK, nCLK input is the selected PLL reference input
1	The single-ended LCLK input is the selected PLL reference input

1. Asynchronous control.

Table 3B. PLL Bypass Select¹

Input	Operation
BYPASS	Operation
0 (default)	The PLL is used for frequency generation
1	The PLL is bypassed. The selected reference frequency is divided by the selected output divider. AC specifications do not apply.

1. Asynchronous control.

Table 3C. Test Mode Select¹

Input	Operation
TEST	Operation
0 (default)	Normal operation. Selected PLL feedback divider is $M = 100$ (integer). $f_{OUT} = \frac{f_{IN} * M}{P * N}$
1	Test mode and frequency margining is enabled. M_T is variable. AC specifications do not apply. $f_{OUT} = \frac{f_{IN} * M_T}{P * N}$ MT values are set by a SPI TEST register

1. Asynchronous control.

Table 3D. LOCK

Output	Operation
LOCK	Operation
0	PLL is not locked to the reference clock
1	PLL is locked to the reference clock

Input Frequency Selection

The input divider P configures the input reference frequency to the PLL. P must be set to match the input frequency to the PLL feedback frequency at the phase detector. The feedback divider M is fixed to $M = 100$ in normal mode. The range of available P divider values supports the input frequencies of 25MHz, 50MHz, 100MHz or 200MHz. P can be set by the content of a SPI register (see Table 3E) and defaults to $P = 8$ after power-up.

Table 3E. P[1:0] Input Divider Function Table

P		$P = \frac{f_{IN} * M}{f_{VCO}}$
P1	P0	Output Operation ($f_{VCO} = 2500\text{MHz}$)
0	0	$P = 1; f_{IN} = 25\text{MHz}$
0	1	$P = 2; f_{IN} = 50\text{MHz}$
1	0	$P = 4; f_{IN} = 100\text{MHz}$
1 (default)	1 (default)	$P = 8; f_{IN} = 200\text{MHz}$

Output Frequency Selection

The output divider N of each of the three output banks controls the frequency for the outputs QA[0:4], QB[0:3] and QC[0:3] and can be set by the content of SPI registers (see Table 3F).

Table 3F. Nm[1:0] Output Divider Function Table¹

Nm		Output Operation ($f_{VCO} = 2500\text{MHz}$)
Nm1	Nm0	Output Operation ($f_{VCO} = 2500\text{MHz}$)
0	0	$N = 16; f_{OUT_m} = 156.25\text{MHz}$
0	1	$N = 20; f_{OUT_m} = 125\text{MHz}$
1	0	$N = 25; f_{OUT_m} = 100\text{MHz}$
1	1	$N = 100; f_{OUT_m} = 25\text{MHz}$

1. "m" denotes output Bank A, B and C.

LVC MOS Output Phase

Outputs of the 8V44N4614 can invert the output phase, forming a differential output with the neighboring LVC MOS output. Example

Table 3G. LVC MOS Output Phase Inversion

IN V _n	Output operation LVC MOS outputs
0 (default)	Normal
1	Inverted

configuration to form differential LVC MOS outputs: Set to logic 1 (inverted): INVA4, INVB1, INVB3, INVC1 and INVC3:

- QA4 (co-located to QA3). Differential LVC MOS pair: QA3, QA4
- QB1 (co-located to QB0). Differential LVC MOS pair: QB0, QB1
- QB3 (co-located to QB2). Differential LVC MOS pair: QB2, QB3
- QC1 (co-located to QC0). Differential LVC MOS pair: QC0, QC1
- QC3 (co-located to QC2). Differential LVC MOS pair: QC2, QC3

When configured as differential LVC MOS, the outputs will generate less noise (better cycle-to-cycle and period jitter). The differential LVC MOS architecture of the device must be supported by equal line length, loading and differential routing on the application board.

Configurable Output Levels

The three differential outputs of the QA bank can be individually configured for LVDS and LVPECL levels (see [Table 3H](#)). Settings are made through the SPI interface.

Table 3H. LEV_n Output Level Function Table¹

LEV _n	Output Level
0 (default)	LVDS
1	LVPECL

1. n stands for a differential output of Bank A

Output Enable Operation

The device supports an enable/disable (high-impedance) function for each individual output. The enable/disable state is pre-set by the content of two SPI registers sets, ENA[12:0] and ENB[12:0]. Each set contains 13 bits that is mapped 1:1 to the 13 outputs. A logic one in these register bits correspond to the output enable state, logic 0 to the output disable state. Two hardware pins (OENA and OENB) control which of ENA, ENB register sets configure the outputs enable state. For instance, if the hardware pins OENA = 1 and OENB = 0, the device selects the 13 ENA bits for controlling the individual output enable function; the ENB bits are ignored. By using the OENA and OENB hardware pins, the user can switch between two pre-configured output enable configuration sets, disable all outputs at once perform a logic-OR function between the two register sets (see [Table 3I](#)).

On power-up, the ENA and ENB register sets load default settings. These default settings can be customized during final test of each device using build-in one-time programmable cells.

After the first valid SPI write, the output enable state is controlled by the SPI registers. Setting and changing the output enable state through the SPI interface is asynchronous to the input reference clock.

Table 3I. OENA, OENB Indirect Output Enable Control

OENA	OENB	Operation
0	0	All outputs are disabled regardless of the ENA[12:0], ENB[12:0] register bit contents.
0	1	The output enable/disable state of each output is defined by the corresponding bit in the ENB [12:0] register set.
1	0	The output enable/disable state of each output is defined by the corresponding bit in the ENA [12:0] register set. OENA=1, OENB=0 is the default configuration that is loaded on power-up if OENA and OENB are left open.
1	1	The output enable/disable state of each output is defined by the result of the logic-OR operation between the corresponding bits of the ENA [12:0], ENB [12:0] register sets. Example: the output QA1 is enabled if either EAN[1] or ENB[1] is set to logic 1, otherwise QA1 is disabled.

Table 3J. Individual Output Enable Control^{1, 2}

Bit	Operation
ENAn, ENBn	Operation
0	LVDS: Output Q _n , nQ _n is disabled high-impedance state. LVC MOS: Output Q _n is disabled in high-impedance state.
1	LVDS: Output Q _n , nQ _n is enabled. LVC MOS: Output Q _n is enabled.

1. n stands for an individual output (QA[0:4], QB[0:3] and QC[0:3]). The default / power-up state is one-time programmable.

2. See [Table 3I](#) for how the OENA, OENB inputs control the ENA and ENB registers.

Test Mode: Output Frequency Margining

The 8V44N4614 supports a test operation by setting the TEST input to logic high level. In test mode, the PLL allows to vary its center frequency. While the input frequency stays constant, all outputs change its frequency following the PLL frequency variation. The test mode supports 19.53125ppm frequency steps and to a total

frequency variation range of ± 507.8125 ppm. To facilitate this test mode, the fractional PLL feedback divider M_T is used. M_T consists of an integer part (M_{INT}) and a fractional part (M_{FRAC}). The amount of frequency variation can be configured by the content of the Test Control SPI registers. [Table 3K](#) illustrates the available settings.

Table 3K. Test Mode Frequency Variation

Output Frequency Variation (ppm)	Absolute Frequency Variation		M_T (Binary)	
	from 100MHz (kHz)	from 156.25MHz (kHz)	$M_{INT}[6:0]$	$M_{FRAC}[8:0]$
-507.81250	-50.78125	-79.34570	1100011	111100110
-488.28125	-48.82813	-76.29395	1100011	111100111
....
-39.06250	-3.90625	-6.10352	1100011	111111110
-19.53125	-1.95313	-3.05176	1100011	111111111
0.00000	0	0	1100100	000000000
19.53125	1.95313	3.05176	1100100	000000001
39.06250	3.90625	6.10352	1100100	000000010
....
488.28125	48.82813	76.29395	1100100	000011001
507.81250	50.78125	79.34570	1100100	000011010

Serial Control Port Description

The 8V44N4614 has a serial control port capable of responding as a slave in an SPI configuration to allow read and write access to any of the internal registers ([Table 4A](#)) for device programming or read back. The SPI interface consists of the SPICLK (clock), MISO (serial data output), MOSI (serial data input) and nCS (chip select) pins. See [Figure 1](#) for a supported SPI configuration the specific sections for each register for details on meanings and default conditions.

SPI Mode Operation

During a SPI data transfer, data is shifted out serially from MISO and shifted in serially from MOSI simultaneously. The SPI clock synchronizes both transmitting and receiving of the two serial data pins. A data transfer consists any integer multiple of 32 bits and is always initiated by a SPI master on the bus.

If nCS is at logic high, the MISO data output is in high-impedance state and the SPI interface of the 8V44N4614 is disabled.

Starting a data transfer requires nCS to set and hold at logic low level during the entire transfer. SPI word (32 bit) and back-to-back transfers of multiple words of 32 bits are supported, during multiple transfers nCS can stay at logic low level.

Setting nCS = 0 will enable the MISO output and present the last bit position of the shift register (D31) at that output. The *first* rising edge of SPICLK will transfer the bit applied to the MOSI input into the first bit, (bit position D0) of the internal shift register and the following SPICLK *falling* edge will output the next bit of the internal shift register to the MISO output. Each SPICLK cycle will further input one bit to

MOSI, shift the content of the shift register by one position and present the last bit to the MISO output. With a total of 32 SPICLK cycles, 32 bit are transferred from the master to the 8V44N4614 slave and also 32 bit are transferred from the slave to the master. During each transfer, the original data content of the internal shift register is replaced by the data shifted in through the MOSI pin.

Internal register data is organized in SPI words of 32 bit. The first bit presented by the SPI master in each transfer is the LSB (least significant bit).

Write operation to a 8V44N4614 register: During a write transfer, a SPI master transfers one or more words of 32 bits data into the internal registers of the 8V44N4614. A write transfer must set the direction bit R/Wn (D4) to 0 (Write) and D0 to D3 must contain the 4-bit register base address A[0:3]. Bits D5 to 31 contain 27 bit of payload data, which is written into the base register addressed by A[0:3] at the end of the write transfer. The word format of the 32-bit word in the shift register is shown in [Table 3L](#). Each transferred SPI word writes the information to four internal 8-bit registers at once. The 8-bit registers in the 8V44N4614 have been organized so that the 5 address + direction bits in each 32-bit base register row are not used for data transfer (only 27 bits are used). Each base address supports 4 registers at the byte offsets 00, 01, 10 and 11.

Read operation from an internal register: a read operation contains of a single 32 bit transfer. The first bits shifted into the shift register are the 4 base address bits A[0:3] and the direction bit R/Wn (D4) which must be to 1 to indicate a read transfer. While these first five bits are shifted in, the MISO output presents the last 5 bits shifted into the shift register with the previous transfer. After the first 5 bits are shifted into MOSI, 27 bit register content addressed by A[0:3] are loaded into the shift register and the next 27 SPICLK clock cycles will then present the loaded register data on MISO and transfer these to the master.

Transfers must be completed with de-asserting nCS after any multiple 32 SPICLK cycles. If nCS is de-asserted at any other number of SPICLKs, the SPI behavior is undefined.

During both read and write operation, the MISO output remains active and each falling SPICLK edge clocks out the last bit of the serial shift register.

After nCS de-asserting to logic 1, the SPI bus is available to transfers to other slaves on the SPI bus. After power-up, the content of the shift register is 32x logic 0.

Table 3L. SPI Mode Serial Word Structure

	LSB									MSB
Bit #	D0	D1	D2	D3	D4	D5	...	D30	D31	
Meaning	A[0:3] Register Base Address				R/Wn Read = 1 Write = 0	D[5:31] Payload Data				
Width	4				1	27				

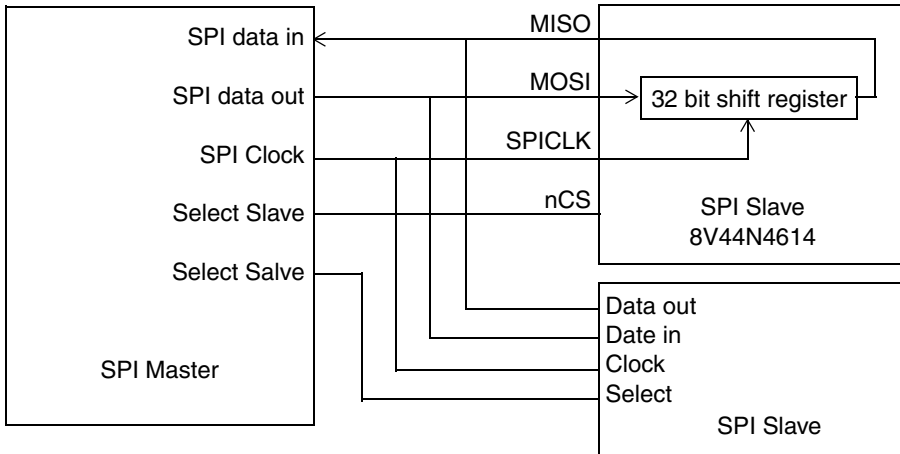

Figure 1. Supported SPI Slave Configuration

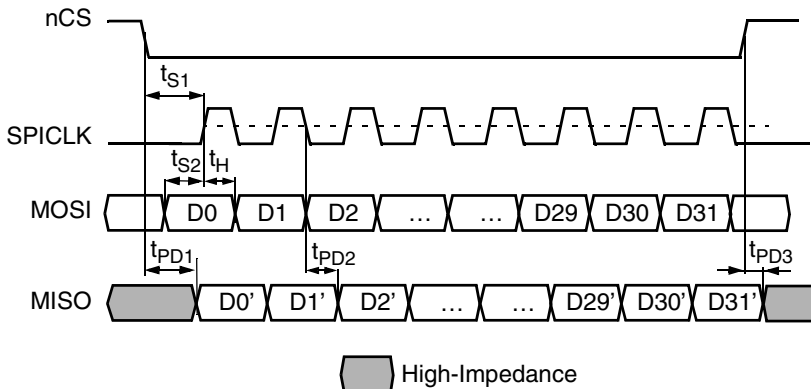

Figure 2. SPI Timing Diagram (Single Transfer)

Table 3M. SPI Read / Write Cycle Timing Parameters

Symbol	Parameter	Test Condition	Minimum	Maximum	Unit
f _{CLK}	SPICLK frequency			20	MHz
t _{S1}	Setup time, nLE to SPICLK (rising)		5		ns
t _{S2}	Setup time, MOSI to SPICLK (rising)		5		ns
t _H	Hold time, SPICLK (rising) to MOSI		5		ns
t _{PD1}	Propagation delay, nLE to MISO enabled			5	ns
t _{PD2}	Propagation delay, SPICLK (falling) to MISO			5	ns
t _{PD3}	Propagation delay, nLE to MISO disable			5	ns

Register Descriptions

The Serial Control port of the 8V44N4614 supports SPI mode operation, which is a 32-bit access.

Table 4A below indicates how registers may be accessed. In 32-bit SPI mode, the least significant 4-bits of the 32-bits shifted in to the serial control port shift register represent the base address of the 32-bit register as indicated in the 1st column in Table 4A. The 5th least significant bit indicates if this is a read (1) or write (0) access. The reader may note that all registers in the Byte Offset 0 column of the table do not make use of the lower 5-bits to support this mode of operation.

All writable register fields will come up with a default values as indicated in the Factory Defaults column unless altered by values loaded from non-volatile storage during the initialization sequence. Fixed read-only bits will have defaults as indicated in their specific register descriptions. Read-only status bits will reflect valid status of the conditions they are designed to monitor once the internal power-up reset has been released. Unused registers and bit positions are Reserved. Reserved bit fields will be unaffected by writes and are undefined on reads. Note: All registers listed as Reserved will be 0x00 on reads and unaffected by writes.

Table 4A. SPI Register Map

Register Base Address (binary)	Register Name			
	Byte Offset = 11	Byte Offset = 10	Byte Offset = 01	Byte Offset = 00
0000	Register 3 LVC MOS Output Control Output Enable Control See Table 4D and Table 4F	Register 2 LVC MOS Output Control See Table 4D	Register 1 Divider Control See Table 4B	Register 0 Reserved
0001	Register 7 Output Enable Control See Table 4F	Register 6 Output Enable Control QA Output Level Control See Table 4F and Table 4H	Register 5 Output Enable Control See Table 4F	Register 4 Reserved
0010	Register 11 Test Control See Table 4J	Register 10 Test Control See Table 4J	Register 9 Test Control See Table 4J	Register 8 Reserved
0011	Register 15 Reserved	Register 14 Reserved	Register 13 Reserved	Register 12 Reserved
0100	Register 19 Reserved	Register 18 Reserved	Register 17 Do not use	Register 16 Do not use

Divider Control Register

Table 4B. Divider Control Register Bit Allocations

Register	Register Bit							
	D7	D6	D5	D4	D3	D2	D1	D0
1	P1	P0	NC1	NC0	NB1	NB0	NA1	NA0

Table 4C. Divider Control Register Function Descriptions

Bits	Name	Factory Default	Function	
Nm[1:0]	Output Divider Setting	NA = 01 NB = 11 NC = 10	These bits control the selection of the divider N for the output clock:	
			00	÷16
			01	÷20
			10	÷25
			11	÷100
P[1:0]	PLL Pre-Divider Setting	P = 11	These bits control the selection of the input pre-divider P:	
			00	÷1
			01	÷2
			10	÷4
			11	÷8
m = Output bank A, B, C				

LVC MOS Output Control Register

Table 4D. LVC MOS Output Control Register Bit Allocations

Register	Register Bit							
	D7	D6	D5	D4	D3	D2	D1	D0
2	INVC1	INVC0	INVB3	INVB2	INVB1	INVB0	INVA4	INVA3
3	INVC3	INVC2	Reserved	ENA_QA4	ENA_QA3	ENA_QA2	ENA_QA1	ENA_QA0

Table 4E. LVC MOS Output Control Register Function Descriptions

Bits	Name	Factory Default	Function
INVn	Output Phase Inversion	Reg 2: 1010 1010 Reg 3: 1000 1101	0 = Qn output phase is normal (0°) 1 = Qn output phase is inverted (180°)

Output Enable Control Registers

Table 4F. Output Enable Control Register Bit Allocations

Register	Register Bit							
	D7	D6	D5	D4	D3	D2	D1	D0
3	INVC3	INVC2	Reserved	ENA_QA4	ENA_QA3	ENA_QA2	ENA_QA1	ENA_QA0
5	ENA_QC3	ENA_QC2	ENA_QC1	ENA_QC0	ENA_QB3	ENA_QB2	ENA_QB1	ENA_QB0
6	LEV2	LEV1	LEV0	ENB_QA4	ENB_QA3	ENB_QA2	ENB_QA1	ENB_QA0
7	ENB_QC3	ENB_QC2	ENB_QC1	ENB_QC0	ENB_QB3	ENB_QB2	ENB_QB1	ENB_QB0

Table 4G. Output Enable Register Function Descriptions

Bits	Name	Factory Default	Function
ENA-n	Clock Output Enable A	Reg 3: 1000 1101 Reg 5: 0011 0011	0 = Qn output is disabled in the high-impedance state 1 = Qn output is enabled ENA bit settings are effective as described in Table 3I
ENB-n	Clock Output Enable B	Reg 6: 0000 0010 Reg 7: 1100 0100	0 = Qn output is disabled in the high-impedance state 1 = Qn output is enabled ENB bit settings are effective as described in Table 3I
n = Output (QA[0:4], QB[0:3], QC[0:3])			

Output Level Control Register

Table 4H. QA Output Level Control Register Bit Allocations

Register	Register Bit							
	D7	D6	D5	D4	D3	D2	D1	D0
6	LEV2	LEV1	LEV0	ENB_QA4	ENB_QA3	ENB_QA2	ENB_QA1	ENB_QA0

Table 4I. QA Output Level Control Register Function Descriptions

Bits	Name	Factory Default	Function
LEVn	Differential Output Level	0000 0010	0 = QAn output is LVDS 1 = QAn output is LVPECL
n = Output QA0, A1 and A2			

Test Control Register

Table 4J. Test Control Register Bit Allocations

Register	Register Bit							
	D7	D6	D5	D4	D3	D2	D1	D0
9	MT_INT6	MT_INT5	MT_INT4	MT_INT3	MT_INT2	MT_INT1	MT_INT0	MT_FRAC8
10	MT_FRAC7	MT_FRAC6	MT_FRAC5	MT_FRAC4	MT_FRAC3	MT_FRAC2	MT_FRAC1	MT_FRAC0
11	MT_FRAC0.1	MT_FRAC0.2	Reserved	SKEW	CP_GAIN	DSM_ORD1	DSM_ORD0	DITHER

Table 4K. Test Control Register Function Descriptions

Bits	Name	Factory Default	Function	
MT_INT[6:0]	MT Feedback Divider, Integer part	1100100	Integer part of the test mode PLL feedback divider. The integer value of the feedback divider can be set directly to the desired value:	
			MT_INT[6:0]	Integer (M_T)
			1100011	99
			1100100	100
MT_FRAC[8:0]	M _T Feedback Divider, Fractional part	00000000	The fractional value is set in increments of 19.53125ppm:	
			MT_FRAC[8:0]	ppm
			000000000	0.00000
			000000001	19.53125
			000000010	39.06250
		
			000011001	488.28125
			000011010	507.81250
MT_FRAC0.1 MT_FRAC0.2	M _T Feedback Divider, Fractional part	00		
CP_GAIN	Charge Pump Gain	0	Leave at the default value	
DSM_ORD[1:0]	Delta-Sigma Order	00	Leave at the default value	
DITHER	DSM Dither Enable	0	Leave at the default value	
SKEW	Phase Delay	1	0 = No Phase Delay added 1 = Phase Delay added ±16 output divider: 0ps ±20 output divider: +225ps (typical) ±25 output divider: +350ps (typical) ±100 output divider: +530ps (typical) Phase Delay values apply for the VCO frequency of 2500MHz. SKEW = 1 adds phase delay between outputs that use different output dividers for reducing cycle and period jitter.	

Register Defaults

This table contains the default settings that is loaded into the device after reset.

Table 4L. Register Function Descriptions

Register	Table	Name	Default	Default Function
0	–	Reserved	000X XXXX	None
1	Table 4B	Divider Control	1110 1101	QA bank: output divider NA = $\div 20$ QB bank: output divider NB = $\div 100$ QC bank: output divider NC = $\div 25$ Input pre-divider: P= $\div 8$
2	Table 4D	LVC MOS Output Control	1010 1010	QC1: inverted phase QC0: normal phase QB3: inverted phase QB2: normal phase QB1: inverted phase QB0: normal phase QA4: inverted phase QA3: normal phase
3	Table 4D Table 4F	LVC MOS Output Control Output Enable Control	1000 1101	QC2: normal phase QC3: inverted phase Enabled: QA0, QA2, QA3 if OENA = 1
4	–	Reserved	000X XXXX	None
5	Table 4F	Output Enable Control	0011 0011	Enabled: QB0, QB1, QC0, QC1 if OENA = 1
6	Table 4F Table 4H	Output Enable Control, QA Output Level Control	0000 0010	LVDS levels: QA0, QA1, QA2 Enabled: QA1 if OENB = 1
7	Table 4F	Output Enable Control	1100 0100	Enabled: QC2, QC3, QB2 if OENB = 1
8	–	Reserved	000X XXXX	None
9	Table 4J	Test Control	8: 1100 1000	MT_INT = 100
10			9: 0000 0000	MT_FRAC = 0 M _T = 100.0 Output variation = 0 ppm
11			0001 0000	SKEW = ON (additional delays are activated)
12	–	Reserved	000X XXXX	None
13	–	Reserved	0000 0000	None
14	–	Reserved	0000 0000	None
15	–	Reserved	0000 0000	None
16	–	Reserved	000X XXXX	Do not use
17	–	Reserved	0000 0000	Do not use.
18	–	Reserved	0000 0000	None
19	–	Reserved	0000 0000	None

Absolute Maximum Ratings

NOTE: Stresses beyond those listed under *Absolute Maximum Ratings* may cause permanent damage to the device. These ratings are stress specifications only. Functional operation of product at these conditions or any conditions beyond those listed in the *DC Characteristics* or *AC Characteristics* is not implied. Exposure to absolute maximum rating conditions for extended periods may affect product reliability.

Table 5A. Absolute Maximum Ratings

Item	Rating
Supply Voltage, V_{DD}	3.6V
Inputs	3.6V
Outputs, V_O (LVCMOS)	3.6V
Outputs, I_O (LVDS) Continuous Current Surge Current	10mA 15mA
Outputs, I_O (LVPECL) Continuous Current Surge Current	50mA 100mA
Storage Temperature, T_{STG}	-65°C to 150°C
Maximum Junction Temperature, T_{JMAX}	125°C
ESD - Human Body Model; NOTE 1	2000V
ESD - Charged Device Model; NOTE 1	500V

NOTE: According to JEDEC JS-001-2012/JESD22-C101.

DC Electrical Characteristics

Table 5B. **Power Supply DC Characteristics**, $V_{DD} = V_{DDI} = V_{DDOA} = V_{DDOB} = V_{DDOC} = 3.3V \pm 5\%$, $GND = 0V$, $T_A = -40^\circ C$ to $+85^\circ C$ ^{1, 2}

Symbol	Parameter	Test Conditions	Minimum	Typical	Maximum	Units
V_{DD}, V_{DDI}	Core Supply Voltage		3.135	3.3	3.465	V
V_{DDA}	Analog Supply Voltage		3.135	3.3	3.465	V
V_{DDOX}	Output Supply Voltage		3.135	3.3	3.465	V
$I_{DD} + I_{DDI}$	Core Supply Current			208	248	mA
I_{DDA}	Analog Supply Current			26	32	mA
I_{DDOX} ³	Output Supply Current			202	245	mA

- V_{DDOX} denotes $V_{DDOA} = V_{DDOB} = V_{DDOC}$.
- I_{DDOX} denotes $I_{DDOA}, I_{DDOB}, I_{DDOC}$.
- All differential outputs are set to LVDS mode and terminated with 100Ω resistors. All LVCMOS outputs are enabled with default frequencies and terminated with 50Ω to $V_{DD}/2$.

Table 5C. **LVC MOS (JESD8-7A, 1.8V) DC Characteristics**, $V_{DD} = V_{DDI} = 3.3V \pm 5\%$, $GND = 0V$, $T_A = -40^\circ C$ to $+85^\circ C$

Symbol	Parameter		Test Conditions	Minimum	Typical	Maximum	Units
V_{IH}	Input High Voltage			1.17		3.3	V
V_{IL}	Input Low Voltage			-0.3		0.63	V
I_{IH}	Input High Current	SPICLK, nCS, MOSI	$V_{DD} = 3.465V, V_{IN} = 1.8V$			5	μA
I_{IL}	Input Low Current	SPICLK, nCS, MOSI	$V_{DD} = 3.465V, V_{IN} = 0V$	-150			μA
V_{OH}	Output High Voltage;	MISO	$I_{OH} = -4mA$	1.35			V
V_{OL}	Output Low Voltage;	MISO	$I_{OL} = 4mA$			0.45	V

Table 5D. **LVC MOS (3.3V) DC Characteristics**, $V_{DD} = V_{DDI} = V_{DDOX}^1 = 3.3V \pm 5\%$, $GND = 0V$, $T_A = -40^\circ C$ to $+85^\circ C$

Symbol	Parameter		Test Conditions	Minimum	Typical	Maximum	Units
V_{IH}	Input High Voltage			2.0		3.3	V
V_{IL}	Input Low Voltage			-0.3		0.8	V
I_{IH}	Input High Current	OENA	$V_{DD} = V_{IN} = 3.465V$			5	μA
		LCLK, OENB, TEST, REFSEL, BYPASS	$V_{DD} = V_{IN} = 3.465V$			150	μA
I_{IL}	Input Low Current	OENA	$V_{DD} = 3.465V, V_{IN} = 0V$	-150			μA
		LCLK, OENB, TEST, REFSEL, BYPASS	$V_{DD} = 3.465V, V_{IN} = 0V$	-5			μA
V_{OH}	Output High Voltage	QA[3:4], QB[0:3], QC[0:3], LOCK	$I_{OH} = -12mA$	2.6			V
V_{OL}	Output Low Voltage	QA[3:4], QB[0:3], QC[0:3], LOCK	$I_{OL} = 12mA$			0.55	V

1. V_{DDOX} denotes $V_{DDOA} = V_{DDOB} = V_{DDOC}$

Table 5E. **Differential Input DC Characteristics**, $V_{DD} = V_{DDI} = 3.3V \pm 5\%$, $GND = 0V$, $T_A = -40^\circ C$ to $+85^\circ C$

Symbol	Parameter		Test Conditions	Minimum	Typical	Maximum	Units
I_{IH}	Input High Current	CLK, nCLK	$V_{DDI} = V_{IN} = 3.465V$			150	μA
I_{IL}	Input Low Current	CLK	$V_{DDI} = 3.465V, V_{IN} = 0V$	-5			μA
		nCLK	$V_{DDI} = 3.465V, V_{IN} = 0V$	-150			μA
V_{PP}	Peak-to-Peak Voltage ¹	CLK, nCLK		0.20		1.3	V
V_{CMR}	Common Mode Input Voltage ^{1, 2}			1.125		V_{DDI}	V

1. Input voltage can not be less than $GND - 300mV$ or more than V_{DDI} .

2. Common mode voltage is defined as the cross point.

Table 5F. **LVDS DC Characteristics**, $V_{DDOA} = 3.3V \pm 5\%$, GND = 0V, $T_A = -40^\circ\text{C}$ to $+85^\circ\text{C}$

Symbol	Parameter	Test Conditions	Minimum	Typical	Maximum	Units
V_{OD}	Differential Output Voltage		247		454	mV
ΔV_{OD}	V_{OD} Magnitude Change				50	mV
V_{OS}	Offset Voltage		1.125		1.4	V
ΔV_{OS}	V_{OS} Magnitude Change				50	mV

 Table 5G. **LVPECL DC Characteristics**, $V_{DDOA} = 3.3V \pm 5\%$, GND = 0V, $T_A = -40^\circ\text{C}$ to $+85^\circ\text{C}$

Symbol	Parameter	Test Conditions	Minimum	Typical	Maximum	Units
V_{OH}	Output High Voltage ¹		$V_{DDOA} - 1.2$		$V_{DDOA} - 0.8$	V
V_{OL}	Output Low Voltage ¹		$V_{DDOA} - 2.0$		$V_{DDOA} - 1.7$	V
V_{SWING}	Peak-to-Peak Output Voltage Swing		0.6		1.0	V

1. NOTE: Outputs terminated with 50Ω to $V_{DDOA} - 2V$.

AC Electrical Characteristics

Table 6. AC Characteristics, $V_{DD} = V_{DDI} = V_{DDOA} = V_{DDOB} = V_{DDOC} = 3.3V \pm 5\%$, $GND = 0V$, $T_A = -40^\circ\text{C}$ to $+85^\circ\text{C}$ ¹

Symbol	Parameter		Test Conditions	Minimum	Typical	Maximum	Units
f_{OUT}	Output Frequency		$Nm[1:0] = 00$		156.25		MHz
			$Nm[1:0] = 01$		125		MHz
			$Nm[1:0] = 10$		100		MHz
			$Nm[1:0] = 11$		25		MHz
f_{IN}	Input Frequency		$P = \div 1$		25		MHz
			$P = \div 2$		50		MHz
			$P = \div 4$		100		MHz
			$P = \div 8$		200		MHz
$t_{sk(o)}$	Output Skew ^{2 3}		Differential Outputs Only			50	ps
			LVC MOS Outputs Only (Same Divider)			180	ps
			LVC MOS Outputs Only (Different Dividers) ⁴			440	ps
$f_{jit(per)}$	RMS Period Jitter ⁵	QA[0:2], nQA[0:2]	10K Cycles; Skew = 1			3	ps
			10K Cycles; Skew = 0			4	ps
		QA[3:4], QB[0:3], QC[0:3]	10K Cycles		1.6	3	ps
$f_{jit(cc)}$	Cycle-to-Cycle Jitter ⁵	QA[0:2], nQA[0:2]	1K Cycles; Skew = 1			20	ps
			1K Cycles; Skew = 0			25	ps
		QA[3:4], QB[0:3], QC[0:3]	1K Cycles		10	25	ps
$f_{jit(\emptyset)}$	RMS Phase Jitter (Random) ⁵		125MHz, Integration Range: 12kHz - 20MHz		0.395	0.542	ps
			100MHz, Integration Range: 12kHz - 20MHz		0.402	0.567	ps
			25MHz, Integration Range: 12kHz - 5MHz		0.428	0.533	ps
t_R / t_F	Output Rise/Fall Time		LVC MOS, 35% to 65%	0.03	0.17	0.99	ns
			LVDS, $\pm 200\text{mV}$ ⁶	0.06	0.20	0.40	ns
odc	Output Duty Cycle ⁷			45	50	55	%
t_{LOCK}	PLL Lock Time		$V_{DD} = 3.3V$		80		ms

1. Electrical parameters are guaranteed over the specified ambient operating temperature range, which is established when the device is mounted in a test socket with maintained transverse airflow greater than 500 lfpm. The device will meet specifications after thermal equilibrium has been reached under these conditions.

2. This parameter is defined in accordance with JEDEC standard 65. Defined as skew between outputs at the same supply voltage and with equal load conditions. Measured at the differential cross points for differential outputs and at $V_{DDOX}/2$ for LVC MOS outputs.

3. SKEW = OFF

4. Test is done under the following configuration: $P = 8$, $NA = 100$, $NB = 25$, $NC = 20$.

NOTES continue on next page.

5. RMS Period Jitter, Cycle-to-Cycle Jitter and RMS Phase Jitter measurements are based on default configurations (Input Clock = 200MHz Differential, $NA = 20$, $NB = 100$, $NC = 25$ and QA4, QB1, QB3, QC1 and QC3 output phases are inverted) and Clean 200MHz input clock is from signal source SRS CG635.

6. Measure differentially QA[0:2] - nQA[0:2].

7. Input duty cycle = 50%

Typical Phase Noise at 125MHz (LVDS Output), 12kHz – 20MHz

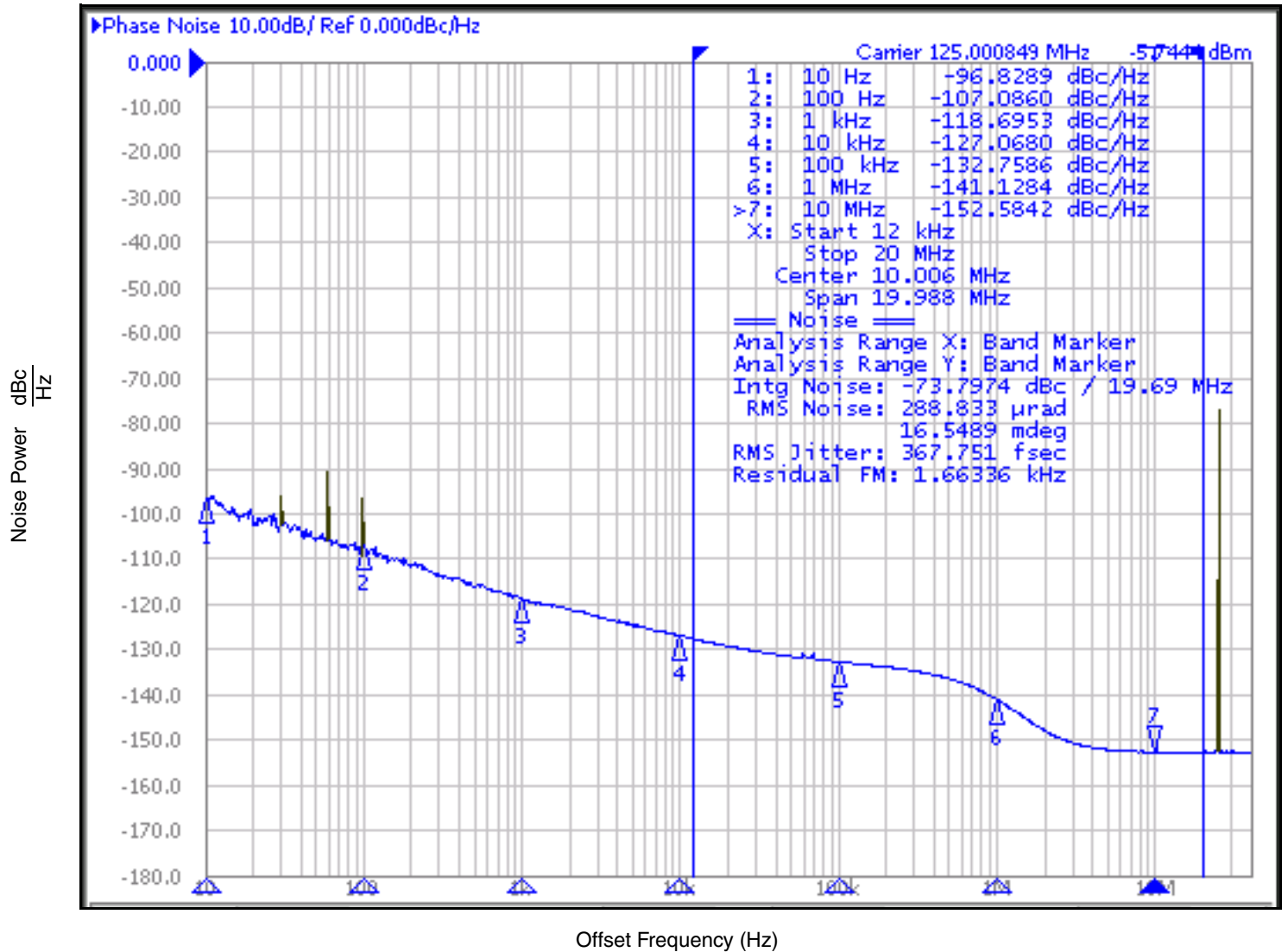

Applications Information

3.3V Differential Clock Input Interface

The CLK /nCLK accepts LVDS, LVPECL and other differential signals. Both V_{SWING} and V_{OH} must meet the V_{PP} and V_{CMR} input requirements. *Figures 1A to 1C* show interface examples for the CLK/nCLK input driven by the most common driver types. The input

interfaces suggested here are examples only. If the driver is from another vendor, use their termination recommendation. Please consult with the vendor of the driver component to confirm the driver termination requirements.

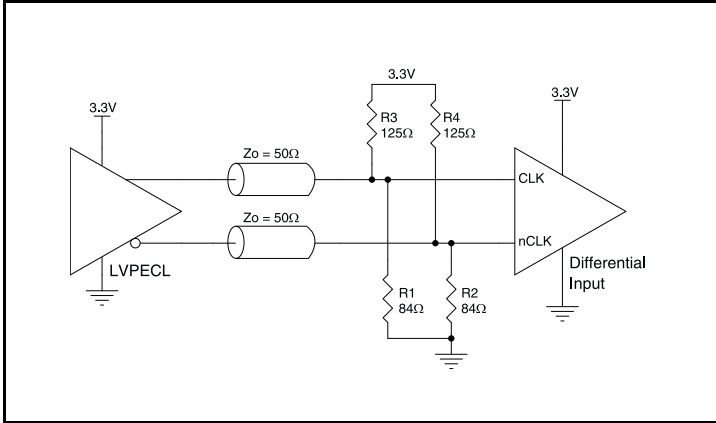

Figure 1A. CLK/nCLK Input Driven by a 3.3V LVPECL Driver

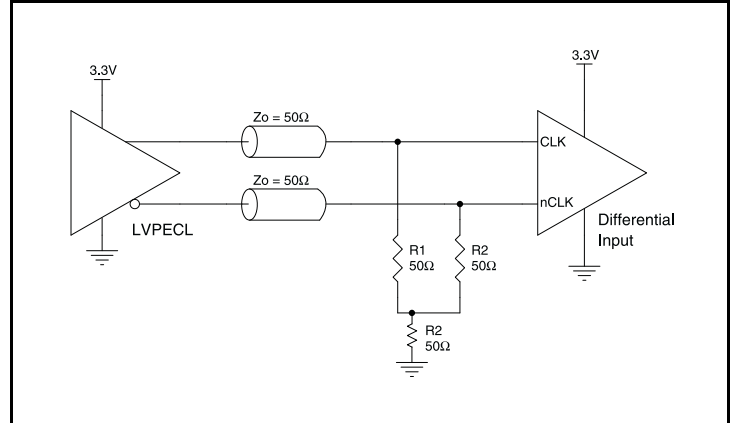

Figure 1B. CLK/nCLK Input Driven by a 3.3V LVPECL Driver

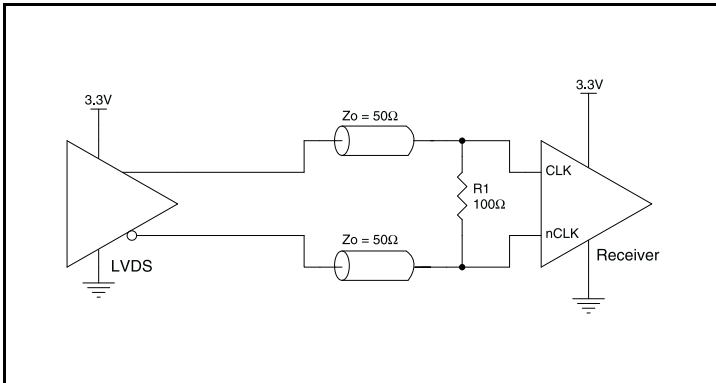
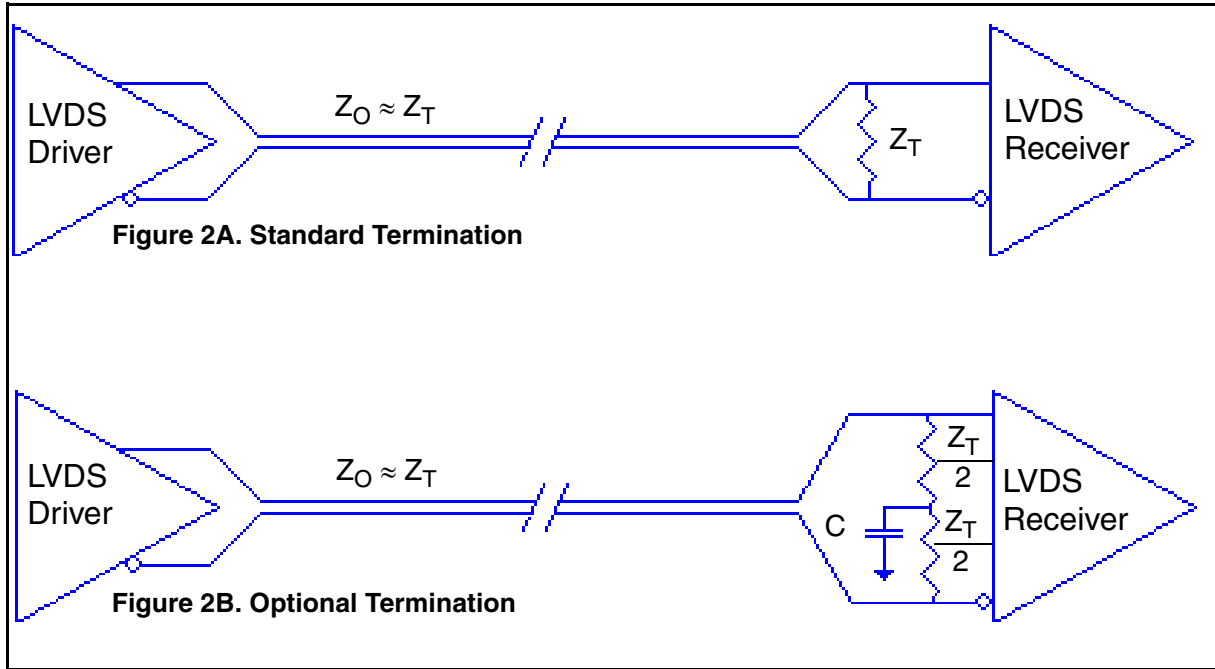

Figure 1C. CLK/nCLK Input Driven by a 3.3V LVDS Driver

LVDS Driver Termination

A general LVDS interface is shown in *Figure 2A*. Standard termination for LVDS type output structure requires both a 100Ω parallel resistor at the receiver and a 100Ω differential transmission line environment. In order to avoid any transmission line reflection issues, the 100Ω resistor must be placed as close to the receiver as possible. IDT offers a full line of LVDS compliant devices with two types of output structures: current source and voltage source. The

standard termination schematic as shown in *Figure 2A* can be used with either type of output structure. If using a non-standard termination, it is recommended to contact IDT and confirm if the output is a current source or a voltage source type structure. In addition, since these outputs are LVDS compatible, the amplitude and common mode input range of the input receivers should be verified for compatibility with the output.



LVDS Driver Termination

Recommendations for Unused Input and Output Pins

Inputs:

LCLK Input

For applications not requiring the use of an alternative clock input, it can be left floating. Though not required, but for additional protection, a $1\text{k}\Omega$ resistor can be tied from the LCLK input to ground.

CLK/nCLK Inputs

For applications not requiring the use of the differential input, both CLK and nCLK can be left floating. Though not required, but for additional protection, a $1\text{k}\Omega$ resistor can be tied from CLK to ground.

LVC MOS Control Pins

All control pins have internal pullups or pulldowns; additional resistance is not required but can be added for additional protection. A $1\text{k}\Omega$ resistor can be used.

Outputs:

LVPECL Outputs

All unused LVPECL output pairs can be left floating. We recommend that there is no trace attached. Both sides of the differential output pair should either be left floating or terminated.

LVDS Outputs

All unused LVDS output pairs can be either left floating or terminated with 100Ω across. If they are left floating, there should be no trace attached.

LVC MOS Outputs

All unused LVC MOS outputs can be left floating. We recommend that there is no trace attached.

Termination for 3.3V LVPECL Outputs

Figures 3A and 3B are examples of typical LVPECL output DC terminations.

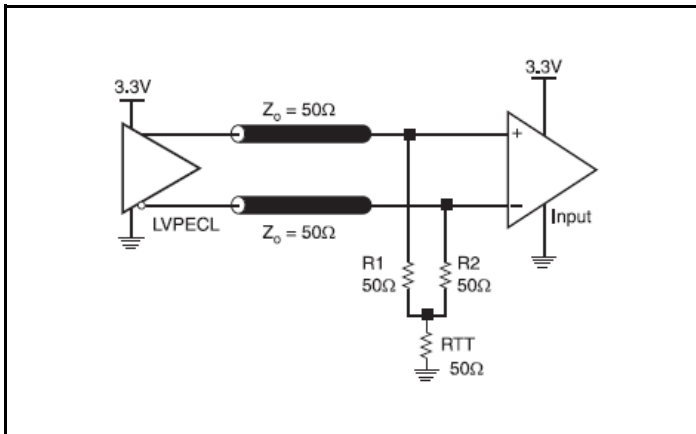

Figure 3A. 3.3V LVPECL Output Termination

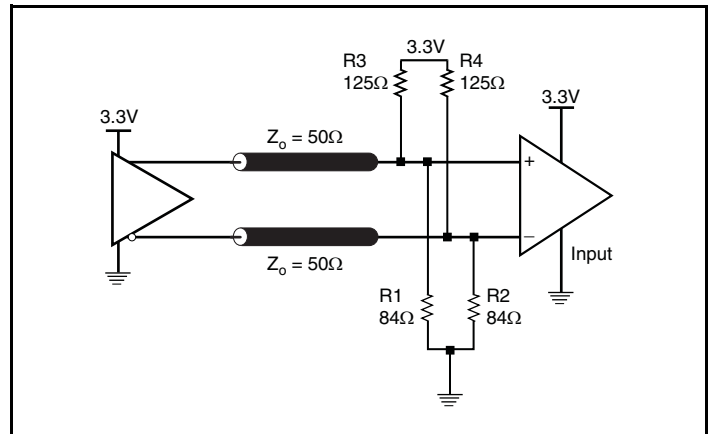

Figure 3B. 3.3V LVPECL Output Termination

VFQFN EPAD Thermal Release Path

In order to maximize both the removal of heat from the package and the electrical performance, a land pattern must be incorporated on the Printed Circuit Board (PCB) within the footprint of the package corresponding to the exposed metal pad or exposed heat slug on the package, as shown in *Figure 4*. The solderable area on the PCB, as defined by the solder mask, should be at least the same size/shape as the exposed pad/slug area on the package to maximize the thermal/electrical performance. Sufficient clearance should be designed on the PCB between the outer edges of the land pattern and the inner edges of pad pattern for the leads to avoid any shorts.

While the land pattern on the PCB provides a means of heat transfer and electrical grounding from the package to the board through a solder joint, thermal vias are necessary to effectively conduct from the surface of the PCB to the ground plane(s). The land pattern must be connected to ground through these vias. The vias act as “heat pipes”. The number of vias (i.e. “heat pipes”) are application specific

and dependent upon the package power dissipation as well as electrical conductivity requirements. Thus, thermal and electrical analysis and/or testing are recommended to determine the minimum number needed. Maximum thermal and electrical performance is achieved when an array of vias is incorporated in the land pattern. It is recommended to use as many vias connected to ground as possible. It is also recommended that the via diameter should be 12 to 13mils (0.30 to 0.33mm) with 1oz copper via barrel plating. This is desirable to avoid any solder wicking inside the via during the soldering process which may result in voids in solder between the exposed pad/slug and the thermal land. Precautions should be taken to eliminate any solder voids between the exposed heat slug and the land pattern. Note: These recommendations are to be used as a guideline only. For further information, please refer to the Application Note on the Surface Mount Assembly of Amkor’s Thermally/Electrically Enhance Leadframe Base Package, Amkor Technology.

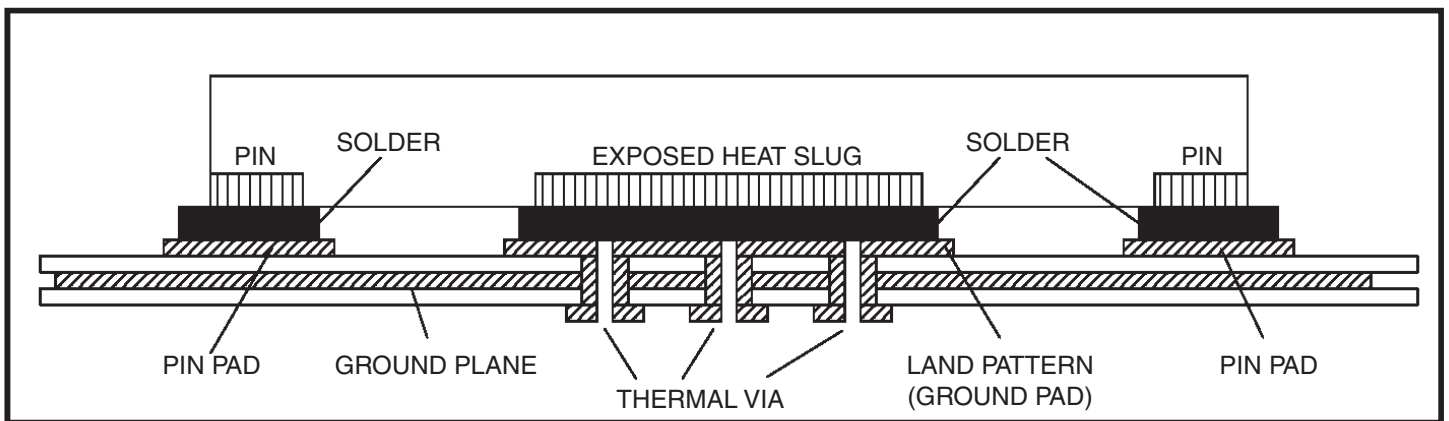

Figure 4. P.C. Assembly for Exposed Pad Thermal Release Path – Side View (drawing not to scale)

Schematic Example

Figure 5 (next page) shows an example 8V44N4614 application schematic in which the device is operated at $V_{DD} = 3.3V$.

This example focuses on functional connections and is not configuration specific. Refer to the pin description and functional tables in the datasheet to ensure that the logic control inputs are properly set for the application.

Three different differential terminations are depicted. QA0 is the standard LVDS termination. QA1 is an example demonstrating how the IDT LVDS outputs can be directly AC coupled to IDT CLK, nCLK clock receiver inputs where the internal bias resistors of the receiver guarantee that the AC coupled LVDS clock is within the common mode range of the receiver. QA2 is an LVPECL Delta termination equivalent to the Wye termination shown on the CLK, nCLK input. This termination is easier to layout in comparison to the Wye termination.

As with any high speed analog circuitry, the power supply pins are vulnerable to random noise. To achieve optimum jitter performance, power supply isolation is required. The 8V44N4614 provides separate power supplies to isolate any high switching noise from coupling into the internal PLL. The Murata BLM18BB221SN1B ferrite bead shown in the schematic was selected for the flat frequency

response realized with the associated filter capacitors. The rated current for this bead is 450mA which will accommodate the maximum current for each power filter.

In order to achieve the best possible filtering, it is recommended that the placement of the filter components be on the device side of the PCB as close to the power pins as possible. If space is limited, the 10 ohm V_{CCA} resistor and the 0.1uF capacitor in each power pin filter should be placed on the device side. The other components can be on the opposite side of the PCB. Pull-up and pull-down resistors to set configuration pins can all be placed on the PCB side opposite the device side to free up device side area if necessary.

Power supply filter recommendations are a general guideline to be used for reducing external noise from coupling into the devices. The filter performance is designed for a wide range of noise frequencies. This low-pass filter starts to attenuate noise at approximately 10kHz. If a specific frequency noise component is known, such as switching power supplies frequencies, it is recommended that component values be adjusted and if required, additional filtering be added. Additionally, good general design practices for power plane voltage stability suggests adding bulk capacitance in the local area of all devices.

For additional layout recommendations and guidelines, contact clocks@idt.com.

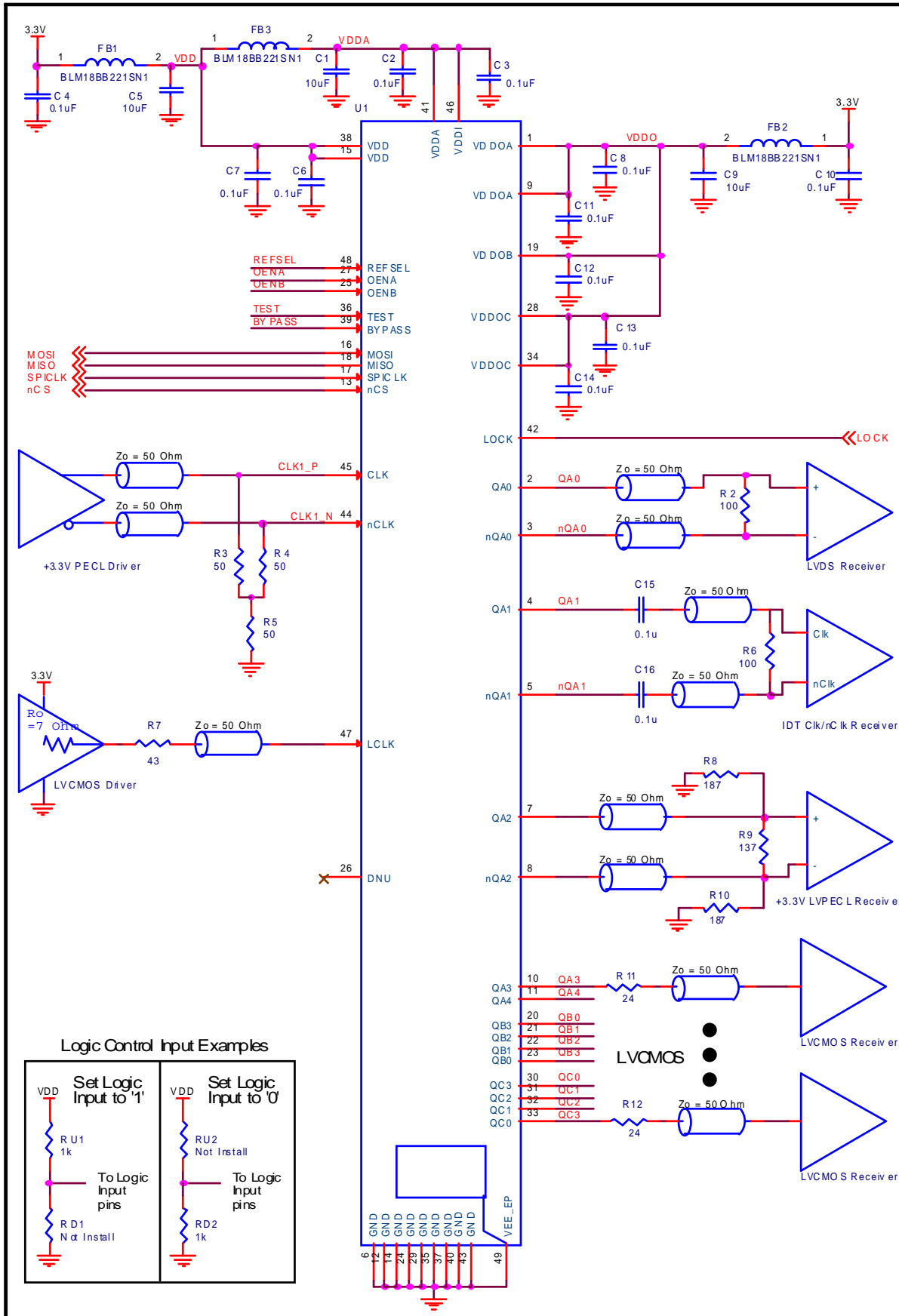

Power Considerations

This section provides information on power dissipation and junction temperature for the 8V44N4614. Equations and example calculations are also provided.

1. Power Dissipation.

The total power dissipation for the 8V44N4614 is the product of supply voltage and total current. The following is the power dissipation for $V_{DD} = 3.3V + 5\% = 3.465V$, at ambient temperature of 85°C.

Maximum current at 85°C, $I_{DD_MAX} = 525mA$

- Total Power Dissipation: $P_D = V_{DD_MAX} * I_{DD_MAX} = 3.465V * 525mA = 1819.13mW$

2. Junction Temperature.

Junction temperature, T_j , signifies the hottest point on the device and exceeding the specified limit could cause device reliability issues. The maximum recommended junction temperature is 125°C.

The equation for T_j using θ_{JA} is: $T_j = \theta_{JA} * P_D + T_A$

T_j = Junction Temperature

θ_{JA} = Junction-to-Ambient Thermal Resistance

P_D = Device Power Dissipation (example calculation is in section 1 above)

T_A = Ambient Temperature

In order to calculate junction temperature, the appropriate junction-to-ambient thermal resistance θ_{JA} must be used. Assuming a 2-ground plane board and no air flow, the appropriate value of θ_{JA} is 21.0°C/W per Table 7 below.

Therefore, T_j for an ambient temperature of 85°C with all outputs switching is:

$$85^\circ\text{C} + 1.819\text{W} * 21^\circ\text{C}/\text{W} = 123.2^\circ\text{C}. \text{ This is below the limit of } 125^\circ\text{C}.$$

This calculation is only an example. T_j will obviously vary depending on the number of loaded outputs, supply voltage, air flow, heat transfer method, the type of board (multi-layer) and the actual maintained board temperature. The below table is for two ground planes. The thermal resistance will change as the number of layers in the board changes or if the board size change and other changes in other factors impacts heat dissipation in the system.

Table 7. Thermal Resistances for 48-Lead VFQFN Package

Air Flow (m/s)	0	1	2
θ_{JB}	1.45°C/W	1.45°C/W	1.45°C/W
θ_{JA}	21.0°C/W	17.52°C/W	16.1°C/W

NOTE: Applicable to PCBs with two ground planes.

NOTE: ePAD size is 5.65mm x 5.65mm and connected to ground plane in PCB through 6 x 6 Thermal Via Array.

NOTE: In devices where most of the heat exits through the bottom ePAD, θ_{JB} can be used for thermal calculations.

Reliability Information

Table 8. θ_{JA} vs. Air Flow Table for a 48 Lead VFQFN

θ_{JA} by Velocity			
Meters per Second	0	1	2
Multi-Layer PCB, JEDEC Standard Test Boards	21.0°C/W	17.52°C/W	16.1°C/W

Transistor Count

The transistor count for 8V44N4614: 42,572

Package Information

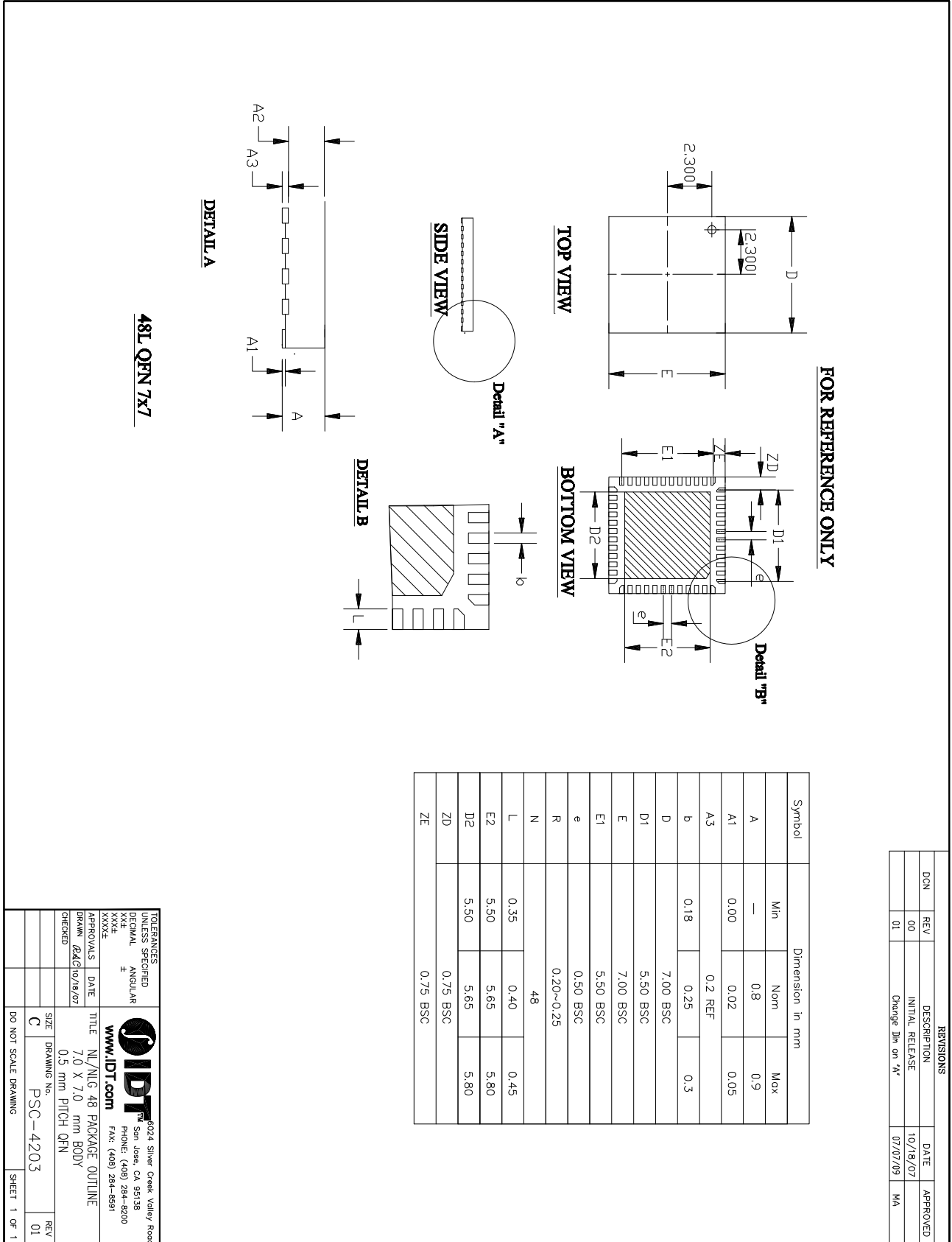

Ordering Information

Table 9. Ordering Information

Part/Order Number	Marking	Package	Shipping Packaging	Temperature
8V44N4614NLGI	IDT8V44N4614NLGI	48 Lead VFQFN, Lead-Free	Tray	-40°C to +85°C
8V44N4614NLGI8	IDT8V44N4614NLGI	48 Lead VFQFN, Lead-Free	Tape & Reel, Pin 1 Orientation: EIA-481-C	-40°C to 85°C
8V44N4614NLGI/W	IDT8V44N4614NLGI	48 Lead VFQFN, Lead-Free	Tape & Reel, Pin 1 Orientation: EIA-481-D	-40°C to 85°C

NOTE: Parts that are ordered with an “G” suffix to the part number are the Pb-Free configuration and are RoHS compliant.

Table 10. Pin 1 Orientation in Tape and Reel Packaging

Part Number Suffix	Pin 1 Orientation	Illustration
8	Quadrant 1 (EIA-481-C)	
/W	Quadrant 2 (EIA-481-D)	



Corporate Headquarters
6024 Silver Creek Valley Road
San Jose, CA 95138 USA

Sales
1-800-345-7015 or 408-284-8200
Fax: 408-284-2775
www.IDT.com

Tech Support
email: clocks@idt.com

DISCLAIMER Integrated Device Technology, Inc. (IDT) and its subsidiaries reserve the right to modify the products and/or specifications described herein at any time and at IDT's sole discretion. All information in this document, including descriptions of product features and performance, is subject to change without notice. Performance specifications and the operating parameters of the described products are determined in the independent state and are not guaranteed to perform the same way when installed in customer products. The information contained herein is provided without representation or warranty of any kind, whether express or implied, including, but not limited to, the suitability of IDT's products for any particular purpose, an implied warranty of merchantability, or non-infringement of the intellectual property rights of others. This document is presented only as a guide and does not convey any license under intellectual property rights of IDT or any third parties.

IDT's products are not intended for use in applications involving extreme environmental conditions or in life support systems or similar devices where the failure or malfunction of an IDT product can be reasonably expected to significantly affect the health or safety of users. Anyone using an IDT product in such a manner does so at their own risk, absent an express, written agreement by IDT.

Integrated Device Technology, IDT and the IDT logo are registered trademarks of IDT. Product specification subject to change without notice. Other trademarks and service marks used herein, including protected names, logos and designs, are the property of IDT or their respective third party owners.

Copyright ©2015 Integrated Device Technology, Inc.. All rights reserved.