



Endicott Research Group, Inc.

2601 Wayne St., Endicott, NY 13760
607-754-9187 Fax 607-754-9255
http://www.ergpower.com

Specifications and Applications Information

08/07/06

Preliminary

The ERG 8mF42859 (*8mF4 Series*) DC to AC inverter features onboard connectors and can be dimmed using an external pulse-width modulated control signal or using the onboard PWM with an external analog voltage. This unit is 9mm in height and the four mounting holes makes installation straight forward.

Powered by a regulated +12 Volt DC source, the 8mF42859 is designed to power the Optrex T-51511D150-FW-A-AC 4 lamp backlight.

Product Features

- ✓ Small Package Size, less than 9 mm in height.
- ✓ High Dimming Ratio
- ✓ High Efficiency
- ✓ Made in U.S.A.

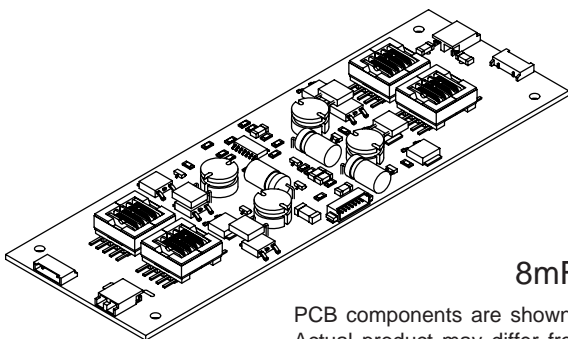

8mF4 Series

PCB components are shown for reference only. Actual product may differ from that shown.

Connectors

Input Molex 53261-0871	Output (2X) JST SM02(4.0)B-BHS-1-TB	Output (2X) JST SM02B-BHSS-1-TB
---------------------------	--	------------------------------------

8mF42859

Four Lamp DC to AC Inverter

Package Configuration

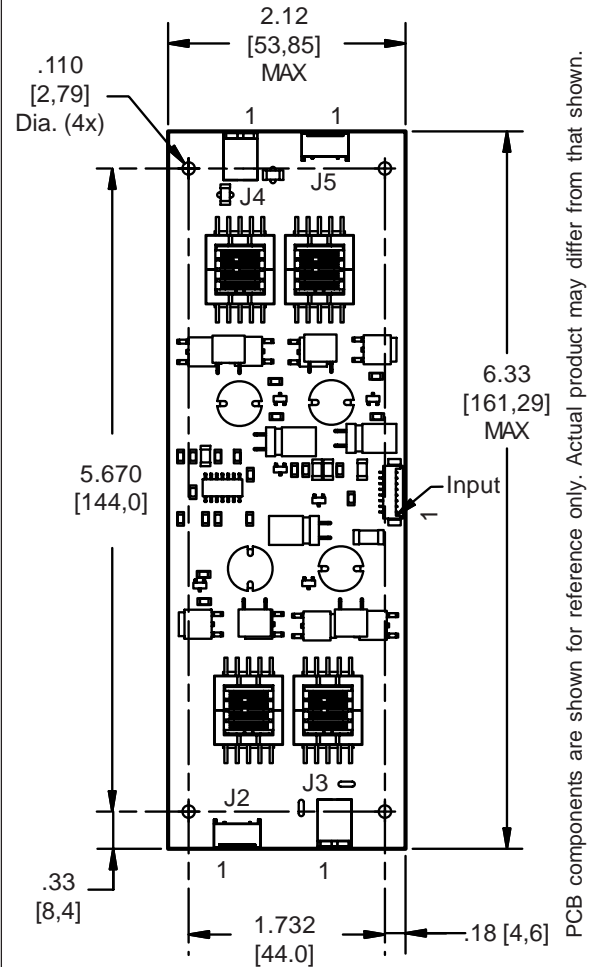

Mass: 93 grams

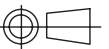

Pin Descriptions

J1-1 Vin		
J1-2 Vin	J2-1 ACcom1	J3-1 ACOut1
J1-3 GND	J2-2 ACcom2	J3-2 ACOut2
J1-4 GND		
J1-5 Enable/PWM		
J1-6 Control		
J1-7 N/C	J5-1 ACcom3	J4-1 ACOut3
J1-8 N/C	J5-2 ACcom4	J4-2 ACOut4

**Absolute Maximum Ratings**

Rating	Symbol	Value	Units
Input Voltage Range	V_{in}	-0.3 to +13.2	Vdc
Storage Temperature	T_{stg}	-40 to +85	°C

Operating Characteristics

With a load simulating the referenced display and lamp warm-up of 20 minutes.
Unless otherwise noted $V_{in} = 12.00$ Volts dc and $T_a = 25^{\circ}\text{C}$.

Characteristic	Symbol	Min	Typ	Max	Units
Input Voltage	V_{in}	+10.8	+12.0	+12.6	Vdc
Component Surface Temperature	T_s	-20	-	+80	°C
Input Current (Note 1)	I_{in}	-	1.52	1.75	Adc
Input Ripple Current	I_{rip}	-	40	-	mA _{pk-pk}
Operating Frequency	F_o	41	46	51	kHz
Minimum Output Voltage	$V_{out}(\text{min})$	1400	-	-	Vrms
Efficiency	η	-	84	-	%
Output Current (per lamp)	I_{out}	-	6.7	-	mArms
Output Voltage	V_{out}	-	570	-	Vrms
Enable Pin					
Turn-off Threshold	V_{thoff}	0	-	1	Vdc
Turn-On Threshold	V_{thon}	2.5	-	V_{in}	Vdc
Impedance to V_{in}	R_{Enable}	9.5	10.0	10.5	kOhms

Specifications subject to change without notice.

(Note 1) Input current in excess of maximum may indicate a load/inverter mismatch condition, which can result in reduced reliability. Please contact ERG technical support.

Application Notes:

- 1) The minimum distance from high voltage areas of the inverter to any conductive material should be .12 inches per kilovolt of starting voltage.
- 2) Mounting hardware should be non-conductive.
- 3) Open framed inverters should not be used in applications at altitudes over 10,000 feet.
- 4) Contact ERG for possible exceptions.



Onboard PWM

Unless otherwise noted $V_{in} = 12.00$ Volts DC , $T_a = 25$ °C and unit has been running for 20 minutes.

Characteristic	Symbol	Min	Typ	Max	Units
Frequency	f_{pwm}	-	160	-	Hz
Control Full On	V_{ctrl}	-	<.5	-	V
Control Full Off	V_{ctrlh}	-	>4.5	-	V
Control Input Bias Current	I_{cbias}	-	-	10	uA

Pin Descriptions

- Vin** Input voltage to the inverter. Both pins should be connected for optimum reliability and efficiency .
- GND** Inverter ground. Both pins should be connected for optimum reliability and efficiency.
- Control** Analog voltage input to the onboard pulse width modulator. Increasing this voltage increases the off time of the onboard PWM resulting in decreased brightness.
- Enable/Disable** Inverter Enable/Disable. If this pin is driven high, the inverter is enabled. Pull this pin low to disable inverter operation.

Application information

The 8mF4 series of inverters is designed to power up to four cold cathode fluorescent lamps with combined power from ten watts to forty watts. An external enable/disable control and an onboard analog controlled pulse width modulator provide flexibility in allowing either PWM or analog methods for dimming. The 8mF4 inverter can reliably dim to less than 0.5% duty cycle, which results in an electrical dimming ratio of greater than 200:1. Depending upon the attached backlight assembly, optical dimming ratios of greater than 1000:1 can be accomplished. Graph 1 shows the relationship of relative brightness to duty cycle for a typical backlight assembly.

External shutdown or external PWM operation of the inverter is accomplished using the Enable/Disable pin. Enabling the inverter is accomplished by pulling this pin high (above V_{thon}). Pulling this pin low (below V_{thoff}) disables the inverter.

If analog voltage dimming is required, the onboard PWM can be enabled. The analog voltage is applied to the Control pin. Figure 1 shows how to connect the inverter for onboard PWM operation. Graph 2 shows the relationship of PWM duty cycle to input control voltage.

If an external PWM is used, connect the enable pin to the PWM source and connect the control pin to the inverter ground. If the onboard PWM is used, connect the analog voltage to the control pin.

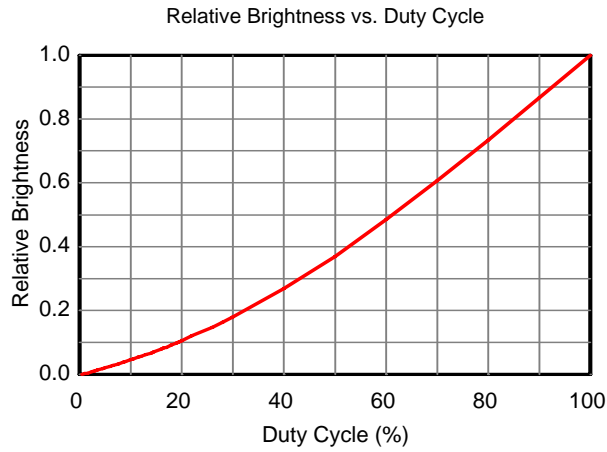

Graph 1

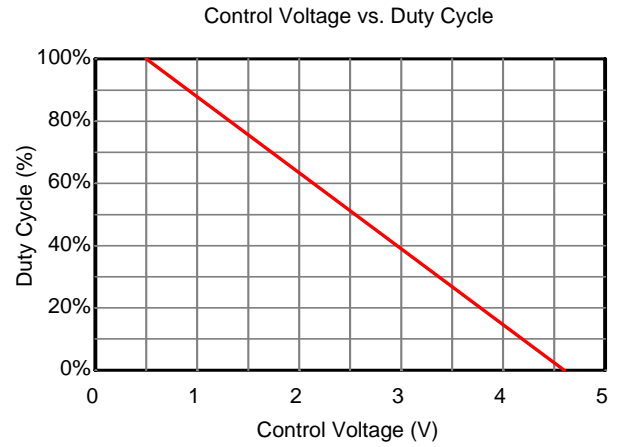

Graph 2

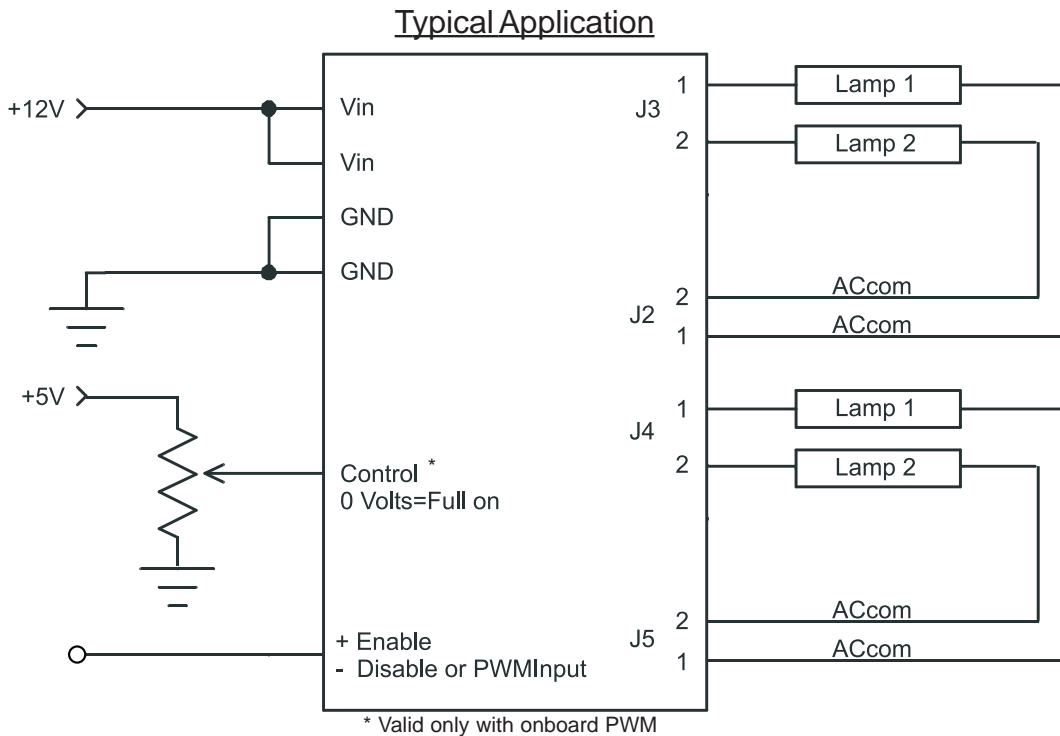

Figure 1



Endicott Research Group, Inc. (ERG) reserves the right to make changes in circuit design and/or specifications at any time without notice. Accordingly, the reader is cautioned to verify that data sheets are current before placing orders. Information furnished by ERG is believed to be accurate and reliable. However, no responsibility is assumed by ERG for its use.