

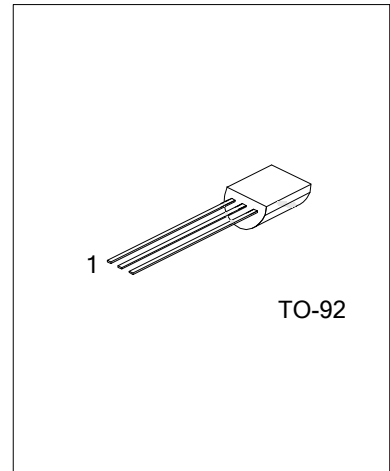

9012

PNP SILICON EPITAXIAL TRANSISTOR

1W OUTPUT AMPLIFIER OF
POTABLE RADIOS IN CLASS
B PUSH-PULL OPERATION



■ FEATURES

- *High total power dissipation. (625mW)
- *High collector current. (-500mA)
- *Excellent hFE linearity
- *Complementary to UTC 9013

■ ORDERING INFORMATION

Ordering Number		Package	Pin Assignment			Packing
Lead Free	Halogen Free		1	2	3	
9012L-x-T92-B	9012G-x-T92-B	TO-92	E	B	C	Tape Box
9012L-x-T92-K	9012G-x-T92-K	TO-92	E	B	C	Bulk

Note: Pin Assignment: B: Base E: Emitter C: Collector

<p>9012L-x-T92-B</p> <p>(1)Packing Type (2)Package Type (3)Rank (3)Lead Free</p>	<p>(1) B: Tape Box, K: Bulk (2) T92: TO-92 (3) x: refer to Classification of h_{FE1} (4) L: Lead Free, G: Halogen Free</p>
--	---

■ MARKING INFORMATION

PACKAGE	MARKING
TO-92	<p>Rank ← → Data Code</p> <p>1</p> <p>UTC 9012 □ □ □ □ □</p> <p>L: Lead Free G: Halogen Free</p>

■ ABSOLUTE MAXIMUM RATING ($T_A=25^\circ\text{C}$, unless otherwise specified)

PARAMETER	SYMBOL	RATINGS	UNIT
Collector-base voltage	V_{CBO}	-40	V
Collector-emitter voltage	V_{CEO}	-20	V
Emitter-base voltage	V_{EBO}	-5	V
Collector current	I_C	-500	mA
Collector dissipation	P_C	625	mW
Junction Temperature	T_J	150	$^\circ\text{C}$
Storage Temperature	T_{STG}	-55 ~ +150	$^\circ\text{C}$

Notes: 1. Absolute maximum ratings are those values beyond which the device could be permanently damaged.
Absolute maximum ratings are stress ratings only and functional device operation is not implied.

■ ELECTRICAL CHARACTERISTICS ($T_A=25^\circ\text{C}$, unless otherwise specified)

PARAMETER	SYMBOL	TEST CONDITIONS	MIN	TYP	MAX	UNIT
Collector-base breakdown voltage	B_{VCBO}	$I_C=-100\mu\text{A}, I_E=0$	-40			V
Collector-emitter breakdown voltage	B_{VCEO}	$I_C=-1\text{mA}, I_B=0$	-20			V
Emitter-base breakdown voltage	B_{VEBO}	$I_E=-100\mu\text{A}, I_C=0$	-5			V
Collector cutoff current	I_{CBO}	$V_{CB}=-25\text{V}, I_E=0$			-100	nA
Emitter cutoff current	I_{EBO}	$V_{EB}=-3\text{V}, I_C=0$			-100	nA
DC current gain	h_{FE1}	$V_{CE}=-1\text{V}, I_C=-50\text{mA}$	64	120	300	
	h_{FE2}	$V_{CE}=-1\text{V}, I_C=-500\text{mA}$	40	90		
Collector-emitter saturation voltage	$V_{CE(sat)}$	$I_C=-500\text{mA}, I_B=-50\text{mA}$		-0.18	-0.6	V
Base-emitter saturation voltage	$V_{BE(sat)}$	$I_C=-500\text{mA}, I_B=-50\text{mA}$		-0.95	-1.2	V
Base-emitter on voltage	$V_{BE(on)}$	$V_{CE}=-1\text{V}, I_C=-10\text{mA}$	-0.6	-0.67	-0.7	V

■ CLASSIFICATION OF h_{FE1}

RANK	D	E	F	G	H	I
RANGE	64-91	78-112	96-135	112-166	144-202	190-300

■ TYPICAL CHARACTERISTICS

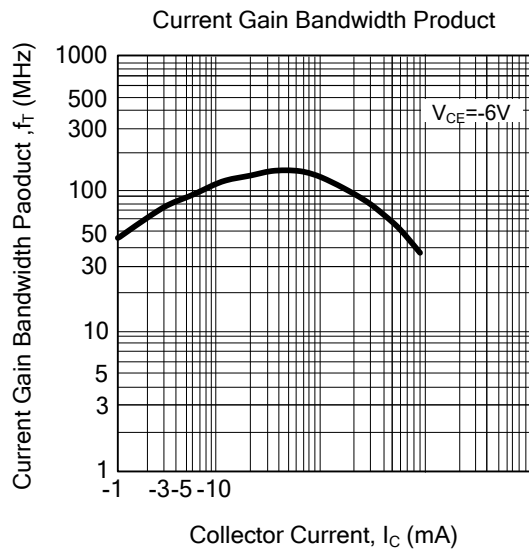
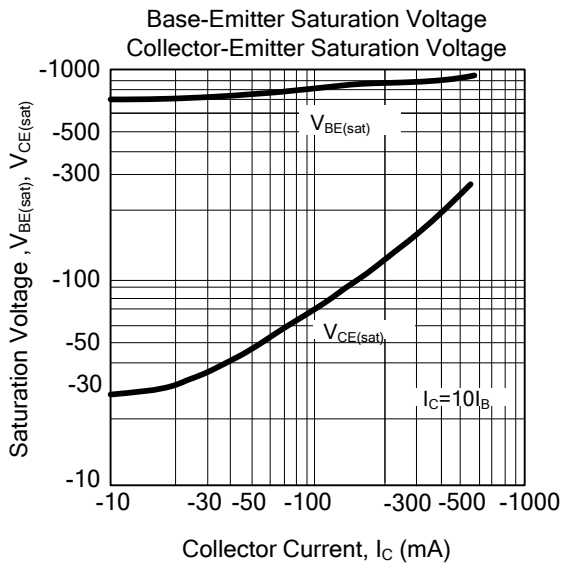
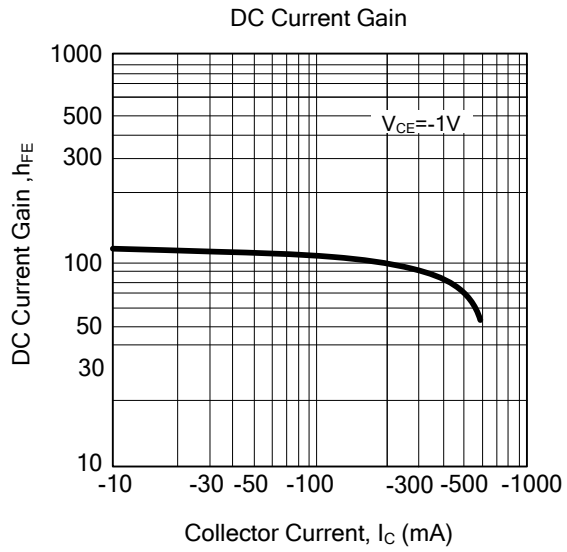
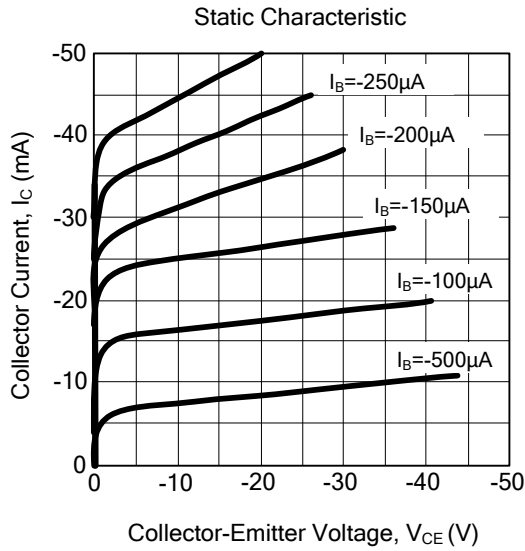

UTC assumes no responsibility for equipment failures that result from using products at values that exceed, even momentarily, rated values (such as maximum ratings, operating condition ranges, or other parameters) listed in products specifications of any and all UTC products described or contained herein. UTC products are not designed for use in life support appliances, devices or systems where malfunction of these products can be reasonably expected to result in personal injury. Reproduction in whole or in part is prohibited without the prior written consent of the copyright owner. The information presented in this document does not form part of any quotation or contract, is believed to be accurate and reliable and may be changed without notice.