

Description

The 9FGL0241 / 9FGL0251 devices are 2-output clock generators in IDT's 3.3V Full-Featured PCIe family. Each output has a dedicated OE# pin for clock management. Two different spread spectrum levels in addition to spread off are supported. The 9FGL0241 / 9FGL0251 supports PCIe Gen1–4 Common Clocked architectures (CC) and PCIe Separate Reference no-Spread (SRnS) and Separate Reference Independent Spread (SRIS) clocking architectures.

Typical Applications

- Servers/High-Performance Computing/Accelerators
- Storage
- Embedded Systems/Industrial Control

Output Features

- Two 100MHz Low-Power HCSL (LP-HCSL) DIF output pairs:
 - 9FGL0241 default Zout = 100Ω
 - 9FGL0251 default Zout = 85Ω
- One 3.3V LVCMOS REF output with Wake-On-LAN (WOL) support
- See [AN-891](#) for easy AC-coupling to other logic families

Key Specifications

- PCIe Gen1–4 CC compliant; Gen2–3 SRIS compliant
- DIF cycle-to-cycle jitter < 50ps
- DIF output-to-output skew < 50ps
- DIF 12kHz–20MHz phase jitter is < 2ps rms when SSC is off
- REF phase jitter is < 300fs rms, SSC off; < 1.5ps rms, SSC on
- ±100ppm frequency accuracy on all clocks

Features

- Direct connection to loads saves 8 resistors compared to standard PCIe devices
- 112mW typical power consumption
- SMBus-selectable optimization features:
 - Control input polarity
 - Control input pull-ups/pull-downs
 - Slew rate for each output
 - Differential output amplitude
 - 33Ω, 85Ω or 100Ω output impedance per output
- SMBus interface not required for device operation at default configuration
- Contact factory for customized versions
- 25MHz input frequency
- Two OE# pins
- Pin-selectable SRnS, CC 0% and CC/SRIS -0.5% spread on DIF outputs
- SMBus-selectable CC/SRIS -0.25% spread
- Clean switching between the CC/SRIS spread spectrum amounts
- DIF outputs blocked until PLL is locked; clean system start-up
- 2 selectable SMBus addresses
- Space-saving 4 × 4 mm 24-VFQFPN package

Block Diagram

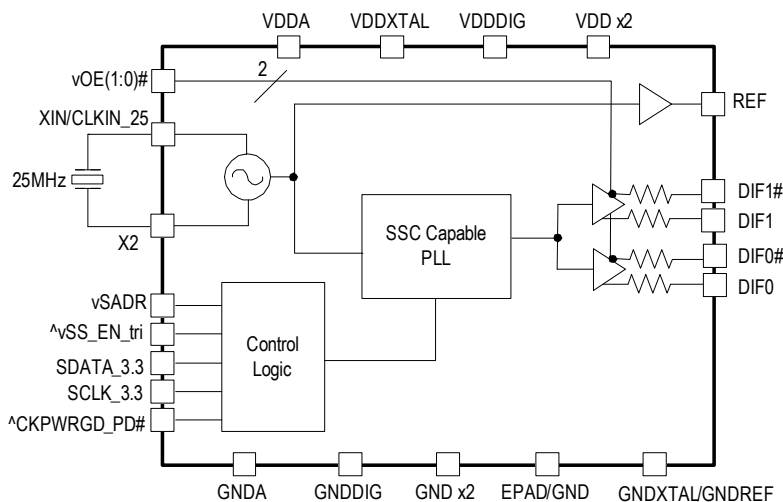

Contents

Description	1
Typical Applications	1
Output Features	1
Key Specifications	1
Features	1
Block Diagram	1
Pin Assignments	3
Pin Descriptions	3
Absolute Maximum Ratings	5
Thermal Characteristics	5
Electrical Characteristics	5
Power Management	11
Test Loads	11
Alternate Terminations	12
Crystal Characteristics	13
General SMBus Serial Interface Information	14
How to Write	14
How to Read	14
Package Outline Drawings	20
Marking Diagrams	20
Ordering Information	20
Revision History	21

Pin Assignments

Figure 1. Pin Assignments for 4 x 4 mm 24-VFQFPN Package – Top View

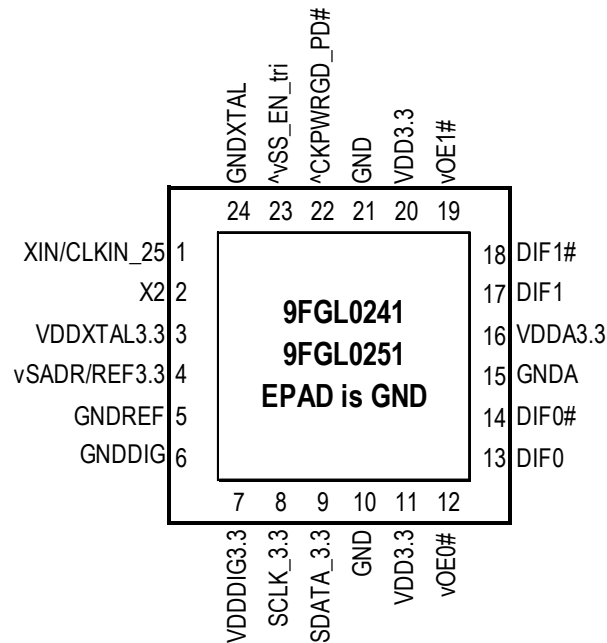

24-VFQFPN, 4 x 4 mm, 0.5mm pitch

^ prefix indicates internal 120kOhm pull-up resistor
 v prefix indicates internal 120kOhm pull-down resistor

Pin Descriptions

Table 1. Pin Descriptions

Number	Name	Type	Description
1	XIN/CLKIN_25	Input	Crystal input or Reference Clock input. Nominally 25MHz.
2	X2	Output	Crystal output.
3	VDDXTAL3.3	Power	Power supply for XTAL. Nominally 3.3V.
4	vSADR/REF3.3	Latched I/O	Latch to select SMBus address/3.3V LVCMOS copy of X1/REFIN pin.
5	GNDREF	GND	Ground pin for the REF outputs.
6	GNDDIG	GND	Ground pin for digital circuitry.
7	VDDDIG3.3	Power	3.3V digital power (dirty power).
8	SCLK_3.3	Input	Clock pin of SMBus circuitry, 3.3V tolerant.
9	SDATA_3.3	I/O	Data pin for SMBus circuitry, 3.3V tolerant.
10	GND	GND	Ground pin.
11	VDD3.3	Power	Power supply. Nominally 3.3V.
12	vOE0#	Input	Active low input for enabling output 0. This pin has an internal pull-down. 1 = disable outputs, 0 = enable outputs.

Table 1. Pin Descriptions (Cont.)

Number	Name	Type	Description
13	DIF0	Output	Differential true clock output.
14	DIF0#	Output	Differential complementary clock output.
15	GNDA	GND	Ground pin for the PLL core.
16	VDDA3.3	Power	3.3V power for the PLL core.
17	DIF1	Output	Differential true clock output.
18	DIF1#	Output	Differential complementary clock output.
19	vOE1#	Input	Active low input for enabling output 1. This pin has an internal pull-down. 1 = disable outputs, 0 = enable outputs.
20	VDD3.3	Power	Power supply. Nominally 3.3V
21	GND	GND	Ground pin.
22	^CKPWRGD_PD#	Input	Input notifies device to sample latched inputs and start up on first high assertion. Low enters Power Down Mode, subsequent high assertions exit Power Down Mode. This pin has internal pull-up resistor.
23	^vSS_EN_tri	Latched I/O	Latched select input to select spread spectrum amount at initial power-up. See Spread Selection table.
24	GNDXTAL	GND	GND for XTAL.
25	EPAD	GND	Connect to ground.

Table 2. Spread Selection

^vSS_EN_tri Pin	B1[4:3]	Spread%	Description
0	00	0	PCIe SRNS mode.
—	01	-0.25	PCIe Common Clock or SRIS mode.
M ($V_{DD}/2$)	10	0	PCIe Common Clock or SRIS mode.
1	11	-0.50	PCIe Common Clock or SRIS mode.

If SRnS mode is desired, power up with ^vSS_EN_tri = '0'. Do not attempt to switch to the other modes via SMBus control in Byte 1. If Common Clock (CC) or SRIS mode is desired, power up with ^vSS_EN_tri at either 'M' or '1'. The desired spread spectrum amount can then be selected via Byte 1 without a requiring a system reset. Once 'M' or '1' is latched at power up, do not attempt to enter SRNS mode or a system reset will be required.

Absolute Maximum Ratings

The absolute maximum ratings are stress ratings only. Stresses greater than those listed below can cause permanent damage to the device. Functional operation of the 9FGL0241 / 9FGL0251 at absolute maximum ratings is not implied. Exposure to absolute maximum rating conditions may affect device reliability.

Table 3. Absolute Maximum Ratings

Parameter	Symbol	Conditions	Minimum	Maximum	Units	Notes
Supply Voltage	V_{DDx}		-0.5	4.6	V	1,2
Input Voltage	V_{IN}		-0.5	$V_{DD} + 0.5$	V	1,3
Input High Voltage, SMBus	V_{IHSMB}	SMBus clock and data pins.		3.9	V	1
Storage Temperature	T_s		-65	150	°C	1
Junction Temperature	T_j			125	°C	1
Input ESD Protection	ESD prot	Human Body Model.	2500		V	1

¹ Guaranteed by design and characterization, not 100% tested in production.

² Operation under these conditions is neither implied nor guaranteed.

³ Not to exceed 4.6V.

Thermal Characteristics

Table 4. Thermal Characteristics

Symbol	Parameter	Package	Typical Values	Units	Notes
θ_{JC}	Junction to case.	NLG24	62	°C/W	1
θ_{Jb}	Junction to base.		5.4	°C/W	1
θ_{JA0}	Junction to air, still air.		50	°C/W	1
θ_{JA1}	Junction to air, 1 m/s air flow.		43	°C/W	1
θ_{JA3}	Junction to air, 3 m/s air flow.		39	°C/W	1
θ_{JA5}	Junction to air, 5 m/s air flow.		38	°C/W	1

¹ EPAD soldered to board.

Electrical Characteristics

$T_A = T_{AMB}$. Supply voltages per normal operation conditions; see [Test Loads](#) for loading conditions.

Table 5. SMBus Parameters

Parameter	Symbol	Conditions	Minimum	Typical	Maximum	Units	Notes
SMBus Input Low Voltage	V_{ILSMB}	$V_{DDSMB} = 3.3V$.			0.8	V	
SMBus Input High Voltage	V_{IHSMB}	$V_{DDSMB} = 3.3V$.	2.1		3.6	V	
SMBus Output Low Voltage	V_{OLSMB}	At I_{PULLUP} .			0.4	V	
SMBus Sink Current	I_{PULLUP}	At V_{OL} .	4			mA	
Nominal Bus Voltage	V_{DDSMB}		2.7		3.6	V	

Table 5. SMBus Parameters (Cont.)

Parameter	Symbol	Conditions	Minimum	Typical	Maximum	Units	Notes
SCLK/SDATA Rise Time	t_{RSMB}	(Max. $V_{IL} - 0.15$) to (Min. $V_{IH} + 0.15$).			1000	ns	1
SCLK/SDATA Fall Time	t_{FSMB}	(Min. $V_{IH} + 0.15$) to (Max. $V_{IL} - 0.15$).			300	ns	1
SMBus Operating Frequency	f_{SMB}	SMBus operating frequency.			500	kHz	2

¹ Guaranteed by design and characterization, not 100% tested in production.

² The device must be powered up for the SMBus to function.

Table 6. Input/Supply/Common Parameters – Normal Operating Conditions

Parameter	Symbol	Conditions	Minimum	Typical	Maximum	Units	Notes
Supply Voltage	V_{DDxxx}	Supply voltage for core, analog and single-ended LVCMOS outputs.	3.135	3.3	3.465	V	
Ambient Operating Temperature	T_{AMB}	Industrial range.	-40	25	85	°C	
Input High Voltage	V_{IH}	Single-ended inputs, except SMBus.	$0.75 \times V_{DDx}$		$V_{DDx} + 0.3$	V	
Input Low Voltage	V_{IL}		-0.3		$0.25 \times V_{DDx}$	V	
Input High Voltage	$V_{IHCLKIN}$	Single-ended tri-level inputs ('_tri' suffix).	$0.75 \times V_{DDx}$		$V_{DDx} + 0.3$	V	
Input Mid Voltage	$V_{IMCLKIN}$		$0.4 \times V_{DDx}$	$0.5 \times V_{DDx}$	$0.6 \times V_{DDx}$	V	
Input Low Voltage	$V_{ILCLKIN}$		-0.3		$0.25 \times V_{DDx}$	V	6
Input Current	I_{IN}	Single-ended inputs, $V_{IN} = GND$, $V_{IN} = V_{DD}$.	-5		5	μA	
	I_{INP}	Single-ended inputs. $V_{IN} = 0V$; inputs with internal pull-up resistors. $V_{IN} = V_{DD}$; inputs with internal pull-down resistors.	-50		50	μA	
Input Frequency	F_{IN}	XTAL or X1 input.	8	25	40	MHz	4
Pin Inductance	L_{pin}				7	nH	1
Capacitance	C_{IN}	Logic inputs, except DIF_IN.	1.5		5	pF	1
	C_{OUT}	Output pin capacitance.			6	pF	1
CLK Stabilization	t_{STAB}	From V_{DD} power-up and after input clock stabilization or deassertion of PD# to 1st clock.		0.34	1.8	ms	1,2
SS Modulation Frequency	f_{MOD}	Allowable frequency (triangular modulation).	30	31.6	33	kHz	1
OE# Latency	$t_{LATOE\#}$	DIF start after OE# assertion. DIF stop after OE# deassertion.	1		3	clocks	1,3

Table 6. Input/Supply/Common Parameters – Normal Operating Conditions (Cont.)

Parameter	Symbol	Conditions	Minimum	Typical	Maximum	Units	Notes
Tdrive_PD#	t_{DRVPD}	DIF output enable after PD# de-assertion.		28	300	μs	1,3
Fall Time	t_F	Fall time of single-ended control inputs.			5	ns	1,2
Rise Time	t_R	Rise time of single-ended control inputs.			5	ns	1,2

¹ Guaranteed by design and characterization, not 100% tested in production.

² Control input must be monotonic from 20% to 80% of input swing.

³ Time from deassertion until outputs are > 200mV.

⁴ Contact the factory for other frequencies.

Table 7. DIF Low-Power HCSL Outputs

Parameter	Symbol	Conditions	Minimum	Typical	Maximum	Units	Notes
Slew Rate	Trf	Scope averaging on, fast setting.	2	2.7	4	V/ns	2,3
		Scope averaging, slow setting.	1.3	1.9	2.8	V/ns	2,3
Crossing Voltage (abs)	Vcross_abs	Scope averaging off.	250	409	550	mV	1,4,5
Crossing Voltage (var)	Δ -Vcross	Scope averaging off.		14	140	mV	1,4,9
Average Clock Period Accuracy	T _{PERIOD_AVG}		-100	0	+2600	ppm	2,10,12,13
Absolute Period	T _{PERIOD_ABS}	Includes jitter and spread spectrum modulation.	9.949	10	10.101	ns	2,6
Jitter, Cycle to Cycle	$t_{j\text{cyc-cyc}}$			16	50	ps	2,15
Voltage High	V _{HIGH}		660	761	850	mV	1
Voltage Low	V _{LOW}		-150	-7	150		1
Absolute Maximum Voltage	V _{MIN}			819	1150	mV	1,7,15
Absolute Minimum Voltage	V _{MAX}		-300	-46			1,8,15
Duty Cycle	t_{DC}		45	49.2	55	%	2
Slew Rate Matching	Δ Trf	Single-ended measurement.		6	20	%	1,14
Skew, Output to Output	t_{sk3}	Averaging on, V _T = 50%.		5	50	ps	2

¹ Measured from single-ended waveform.

² Measured from differential waveform.

³ Measured from -150 mV to +150 mV on the differential waveform (derived from REFCLK+ minus REFCLK-). The signal must be monotonic through the measurement region for rise and fall time. The 300mV measurement window is centered on the differential zero crossing.

⁴ Measured at crossing point where the instantaneous voltage value of the rising edge of REFCLK+ equals the falling edge of REFCLK-.

⁵ Refers to the total variation from the lowest crossing point to the highest, regardless of which edge is crossing. Refers to all crossing points for this measurement.

⁶ Defines as the absolute minimum or maximum instantaneous period. This includes cycle to cycle jitter, relative ppm tolerance, and spread spectrum modulation.

⁷ Defined as the maximum instantaneous voltage including overshoot.

⁸ Defined as the minimum instantaneous voltage including undershoot.

- ⁹ Defined as the total variation of all crossing voltages of Rising REFCLK+ and Falling REFCLK-. This is the maximum allowed variance in V_{CROSS} for any particular system.
- ¹⁰ Refer to Section 8.6 of the PCI Express Base Specification, Revision 4.0 for information regarding ppm considerations.
- ¹¹ System board compliance measurements must use the test load. REFCLK+ and REFCLK- are to be measured at the load capacitors C_L . Single-ended probes must be used for measurements requiring single ended measurements. Either single-ended probes with math or differential probe can be used for differential measurements. Test load $C_L = 2pF$.
- ¹² PCIe Gen1 through Gen4 specify $\pm 300ppm$ frequency tolerances. The 9FGL0xxx devices already meet the tighter $\pm 100ppm$ frequency tolerances proposed for PCIe Gen5 and required by most servers
- ¹³ "ppm" refers to parts per million and is a DC absolute period accuracy specification. 1ppm is 1/1,000,000th of 100.000000MHz exactly or 100Hz. For 300ppm, then we have an error budget of $100Hz/ppm \times 300ppm = 30kHz$. The period is to be measured with a frequency counter with measurement window set to 100ms or greater. The $\pm 300ppm$ applies to systems that do not employ Spread Spectrum clocking, or that use common clock source. For systems employing Spread Spectrum clocking, there is an additional 2,500ppm nominal shift in maximum period resulting from the 0.5% down spread resulting in a maximum average period specification of +2,800ppm.
- ¹⁴ Matching applies to rising edge rate for REFCLK+ and falling edge rate for REFCLK-. It is measured using a ± 75 mV window centered on the median cross point where REFCLK+ rising meets REFCLK- falling. The median cross point is used to calculate the voltage thresholds the oscilloscope is to use for the edge rate calculations. The Rise Edge Rate of REFCLK+ should be compared to the Fall Edge Rate of REFCLK-; the maximum allowed difference should not exceed 20% of the slowest edge rate.
- ¹⁵ At default SMBus amplitude settings.

Table 8. DIF LP-HCSL Output Unfiltered Phase Jitter Parameters

Parameter	Symbol	Conditions	Minimum	Typical	Maximum	Units	Notes
Phase Jitter, 12k-20M	$t_{jph12k20M}$	100MHz outputs with REF output enabled, SSC off.			2	ps (rms)	

Table 9. Current Consumption

Parameter	Symbol	Conditions	Minimum	Typical	Maximum	Units	Notes
Operating Supply Current	I_{DDAOP}	V_{DDA} , All outputs active at 100MHz.		13	17	mA	
	I_{DDOP}	All V_{DD} , except V_{DDA} . All outputs active at 100MHz.		18	23	mA	
Wake-on-LAN Current (Power down state and Byte 3, bit 5 = '1')	I_{DDAPD}	V_{DDA} , DIF outputs off, REF output running.		0.9	1.5	mA	1
	I_{DDPD}	All V_{DD} , except V_{DDA} . DIF outputs off, REF output running.		5.7	8	mA	1
Power Down Current (Power down state and Byte 3, bit 5 = '0')	I_{DDAPD}	V_{DDA} , all outputs off.		0.9	1.5	mA	
	I_{DDPD}	All V_{DD} , except V_{DDA} , all outputs off.		1.7	2.5	mA	

- ¹ This is the current required to have the REF output running in Wake-on-LAN mode (Byte 3, bit 5 = 1).

Table 10. Filtered Phase Jitter Parameters - PCIe Common Clocked (CC) Architectures

Parameter	Symbol	Conditions	Minimum	Typical	Maximum	Industry Limits	Units	Notes
Phase Jitter	$t_{jphPCIeG1-CC}$	PCIe Gen1.		17.2	27	86	ps (p-p)	1,2,3
	$t_{jphPCIeG2-CC}$	PCIe Gen2 Low Band 10kHz < f < 1.5MHz (PLL BW of 5–16MHz or 8–16MHz, CDR = 5MHz).		0.37	0.54	3	ps (rms)	1,2
		PCIe Gen2 High Band 1.5MHz < f < Nyquist (50MHz) (PLL BW of 5–16MHz or 8–16MHz, CDR = 5MHz).		0.98	1.29	3.1	ps (rms)	1,2
	$t_{jphPCIeG3-CC}$	PCIe Gen3 (PLL BW of 2–4MHz or 2–5MHz, CDR = 10MHz).		0.25	0.32	1	ps (rms)	1,2
	$t_{jphPCIeG4-CC}$	PCIe Gen4 (PLL BW of 2–4MHz or 2–5MHz, CDR = 10MHz).		0.25	0.32	0.5	ps (rms)	1,2

 Table 11. Filtered Phase Jitter Parameters - PCIe Separate Reference Independent Spread (SRIS) Architectures³

Parameter	Symbol	Conditions	Minimum	Typical	Maximum	Industry Limits	Units	Notes
Phase Jitter, -0.25% Spread	$t_{jphPCIeG2-SRIS}$	PCIe Gen2 (PLL BW of 16MHz, CDR = 5MHz)		0.59	0.7	2	ps (rms)	1,4,5
	$t_{jphPCIeG3-SRIS}$	PCIe Gen3 (PLL BW of 2-4MHz or 2-5MHz, CDR = 10MHz)		0.38	0.40	0.7	ps (rms)	1,4,5
Phase Jitter, -0.5% Spread	$t_{jphPCIeG2-SRIS}$	PCIe Gen2 (PLL BW of 16MHz, CDR = 5MHz)		0.73	0.93	2	ps (rms)	1,4,5
	$t_{jphPCIeG3-SRIS}$	PCIe Gen3 (PLL BW of 2-4MHz or 2-5MHz, CDR = 10MHz)		0.48	0.61	0.7	ps (rms)	1,4,5

Notes on PCIe Filtered Phase Jitter Tables:

- ¹ Applies to all differential outputs, guaranteed by design and characterization.
- ² Based on PCIe Base Specification Rev4.0 version1.0. See <http://www.pcisig.com> for latest specifications.
- ³ Sample size of at least 100K cycles. This figure extrapolates to 108ps pk-pk at 1M cycles for a BER of 1^{-12} .
- ⁴ IR is the new name for Separate Reference Independent Spread (SRIS) and Separate Reference no Spread (SRnS) PCIe clock architectures
- ⁵ According to the PCIe Base Specification Rev4.0 version 1.0, the jitter transfer functions and corresponding jitter limits are not defined for the IR clock architecture. Widely accepted industry limits using widely accepted industry filters are used to populate this table. The PCIe Base Specification Rev5.0 is expected to resolve this.

Table 12. REF Output

Parameter	Symbol	Conditions	Minimum	Typical	Maximum	Units	Notes
Long Accuracy	ppm	See T _{period} min-max values.	0			ppm	1,2
Clock Period	T _{period}	REF output.	40			ns	2
High Output Voltage	V _{HIGH}	I _{OH} = -2mA.	0.8 x V _{DDREF}			V	
Low Output Voltage	V _{LOW}	I _{OL} = 2mA.			0.2 x V _{DDREF}	V	
Rise/Fall Slew Rate	t _{rf1}	Byte 3 = 1F, V _{OH} = 0.8 x V _{DD} , V _{OL} = 0.2 x V _{DD} .	0.5	0.9	1.5	V/ns	1
	t _{rf1}	Byte 3 = 5F, V _{OH} = 0.8 x V _{DD} , V _{OL} = 0.2 x V _{DD} .	1.0	1.5	2.5	V/ns	1,3
	t _{rf1}	Byte 3 = 9F, V _{OH} = 0.8 x V _{DD} , V _{OL} = 0.2 x V _{DD} .	1.5	2.1	3.0	V/ns	1
	t _{rf1}	Byte 3 = DF, V _{OH} = 0.8 x V _{DD} , V _{OL} = 0.2 x V _{DD} .	2.0	2.7	3.7	V/ns	1
Duty Cycle	d _{t1X}	V _T = V _{DD} /2 V.	45	49.7	55	%	1,4
Duty Cycle Distortion	d _{tcd}	V _T = V _{DD} /2 V.	-1	0	0	%	1,5
Jitter, Cycle to Cycle	t _{jcc-cyc}	V _T = V _{DD} /2 V.		35	125	ps	1,4
Noise Floor	t _{dBc1k}	1kHz offset.		-145	-135	dBc	1,4
	t _{dBc10k}	10kHz offset to Nyquist.		-150	-140	dBc	1,4
Jitter, Phase	t _{jphREF}	12kHz to 5MHz, DIF SSC off.		0.13	0.3	ps (rms)	1,4
	t _{jphREF}	12kHz to 5MHz, DIF SSC on.		1.41	2	ps (rms)	1,4

¹ Guaranteed by design and characterization, not 100% tested in production.

² All Long Term Accuracy and Clock Period specifications are guaranteed assuming that REF is trimmed to 25.00MHz.

³ Default SMBus value.

⁴ When driven by a crystal.

⁵ When driven by an external oscillator via the X1 pin, X2 should be floating.

Power Management

 Table 13. Power Management ³

CKPWRGD_PD#	SMBus OE bit	OEx# Pin	DIF		
			True O/P	Comp. O/P	REF
0	X	X	Low ¹	Low ¹	Hi-Z ²
1	1	0	Running	Running	Running
1	1	1	Disabled ¹	Disabled ¹	Running
1	0	X	Disabled ¹	Disabled ¹	Disabled ⁴

¹ The output state is set by B11[1:0] (Low/Low default).

² REF is Hi-Z until the 1st assertion of CKPWRGD_PD# high. After this, when CKPWRGD_PD# is low, REF is disabled unless Byte3[5] = 1, in which case REF is running.

³ Input polarities defined at default values for 9FGL0241/0251.

⁴ See SMBus description for Byte 3, bit 4.

Table 14. SMBus Address Selection

	SADR	Address	+ Read/Write Bit
State of SADR on first application of CKPWRGD_PD#	0	1101000	X
	1	1101010	X

Table 15. Power Connections

Pin Number		Description
V _{DD}	GND	
3	5, 24	XTAL, REF
7	6	Digital power
11, 20	10, 21, 25	DIF outputs
16	15	PLL analog

Test Loads

Figure 2. Single-ended Output Test Load

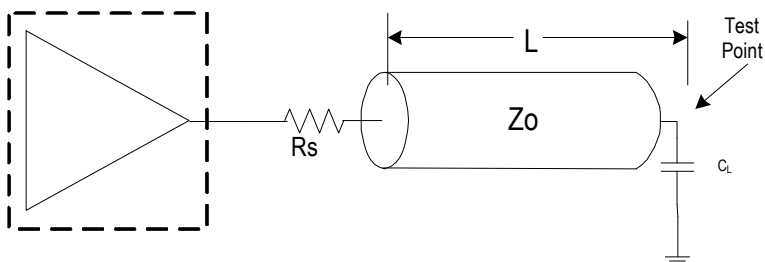

Figure 3. Low-Power HCSL Output Test Load (standard PCIe source-terminated test load)

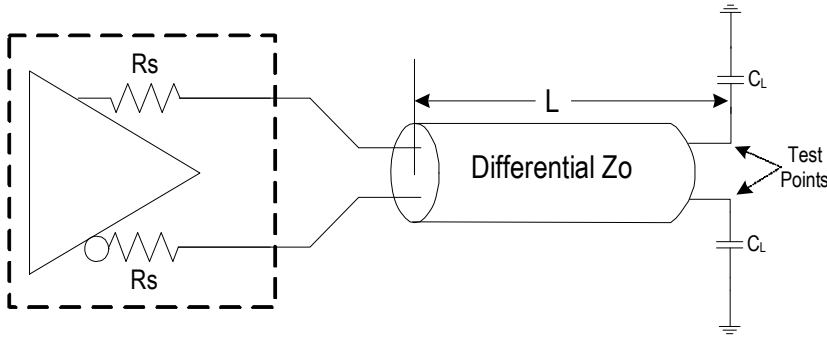

Figure 4. Test Setup for PCIe Jitter Measurements

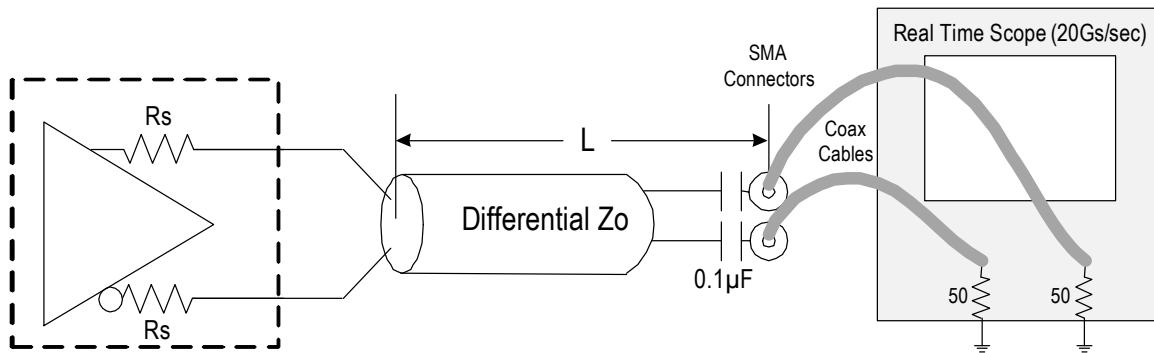

Table 16. Terminations

Device	L (inches)	Zo (Ω)	Rs (Ω)	REF C_L (pF)	DIF C_L (pF)
9FGL0241	5	100	None needed	4.7	2
9FGL0251	5	100	7.5		
9FGL0241	5	85	N/A		
9FGL0251	5	85	None needed		

Alternate Terminations

The 9FGL family can easily drive LVPECL, LVDS, and CML logic. See [“AN-891 Driving LVPECL, LVDS, and CML Logic with IDT’s “Universal” Low-Power HCSL Outputs”](#) for details.

Crystal Characteristics

Table 17. Recommended Crystal Characteristics

Parameter	Value	Units
Frequency	25MHz	MHz
Resonance Mode	Fundamental	—
Frequency Tolerance @ 25°C	±20	ppm maximum
Frequency Stability, reference at 25°C over operating temperature range	±20	ppm maximum
Temperature Range (industrial)	-40 to +85	°C
Temperature Range (commercial)	0 to +70	°C
Equivalent Series Resistance (ESR)	50	Ω maximum
Shunt Capacitance (C_0)	7	pF maximum
Load Capacitance (C_L)	8	pF maximum
Drive Level	0.1	mW maximum
Aging per year	±5	ppm maximum

General SMBus Serial Interface Information

How to Write

- Controller (host) sends a start bit
- Controller (host) sends the write address
- IDT clock will **acknowledge**
- Controller (host) sends the beginning byte location = N
- IDT clock will **acknowledge**
- Controller (host) sends the byte count = X
- IDT clock will **acknowledge**
- Controller (host) starts sending Byte N through Byte N+X-1
- IDT clock will **acknowledge** each byte **one at a time**
- Controller (host) sends a stop bit

Index Block Write Operation		
Controller (Host)		IDT (Slave/Receiver)
T	starT bit	
Slave Address		
WR	WRite	
Beginning Byte = N		ACK
Data Byte Count = X		ACK
Beginning Byte N		ACK
O	X Byte	O
O		O
O		O
Byte N + X - 1		O
ACK		
P	stoP bit	

Note: Unless otherwise indicated, default values are for the 0241, and 0251. Read/Write Address is latched on SADR pin.

How to Read

- Controller (host) will send a start bit
- Controller (host) sends the write address
- IDT clock will **acknowledge**
- Controller (host) sends the beginning byte location = N
- IDT clock will **acknowledge**
- Controller (host) will send a separate start bit
- Controller (host) sends the read address
- IDT clock will **acknowledge**
- IDT clock will send the data byte count = X
- IDT clock sends Byte N+X-1
- IDT clock sends **Byte 0 through Byte X (if $X_{(H)}$ was written to Byte 8)**
- Controller (host) will need to acknowledge each byte
- Controller (host) will send a not acknowledge bit
- Controller (host) will send a stop bit

Index Block Read Operation		
Controller (Host)		IDT (Slave/Receiver)
T	starT bit	
Slave Address		
WR	WRite	
Beginning Byte = N		ACK
Beginning Byte = N		ACK
RT	Repeat starT	
Slave Address		
RD	ReaD	
ACK		ACK
ACK		Data Byte Count=X
ACK		Beginning Byte N
O	X Byte	O
O		O
O		O
O		O
ACK		Byte N + X - 1
N	Not acknowledge	
P	stoP bit	

SMBus Table: Output Enable Register

Byte 0	Name	Control Function	Type	0	1	Default
Bit 7	Reserved					X
Bit 6	Reserved					X
Bit 5	Reserved					X
Bit 4	Reserved					X
Bit 3	Reserved					X
Bit 2	DIF OE1	Output Enable	RW	Low/Low	Pin Control	1
Bit 1	DIF OE0	Output Enable	RW	Low/Low	Pin Control	1
Bit 0	Reserved					X

¹ A low on these bits will override the OE# pin and force the differential output to the state indicated by B11[1:0] (Low/Low default).

SMBus Table: Spread Spectrum and V_{HIGH} Control Register

Byte 1	Name	Control Function	Type	0	1	Default
Bit 7	SSENRB1	SS Enable Readback Bit1	R	See Spread Selection table.		Latch
Bit 6	SSENRB0	SS Enable Readback Bit0	R			Latch
Bit 5	SSEN_SWCNTRL	Enable SW control of SS	RW	SS controlled by latch (B1[7:6]).	Values in B1[4:3] control SS amount.	0
Bit 4	SSENSW1	SS Enable Software Ctl Bit1	RW ¹	See Spread Selection table.		0
Bit 3	SSENSW0	SS Enable Software Ctl Bit0	RW ¹			0
Bit 2	Reserved					X
Bit 1	AMPLITUDE 1	Controls Output Amplitude	RW	00 = 0.6V	01 = 0.68V	1
Bit 0	AMPLITUDE 0		RW	10 = 0.75V	11 = 0.85V	0

¹ See notes on [Spread Selection](#) table. B1[5] must be set to a 1 in order to use B1[4:3].

SMBus Table: DIF Slew Rate and Output Control Register

Byte 2	Name	Control Function	Type	0	1	Default
Bit 7	Reserved					X
Bit 6	Reserved					X
Bit 5	Reserved					X
Bit 4	Reserved					X
Bit 3	Reserved					X
Bit 2	SLEWRATESEL DIF1	Adjust Slew Rate of DIF1	RW	Slow Setting	Fast Setting	1
Bit 1	SLEWRATESEL DIF0	Adjust Slew Rate of DIF0	RW	Slow Setting	Fast Setting	1
Bit 0	Reserved					X

Note: See [DIF Low-Power HCSL Outputs](#) table for slew rates.

SMBus Table: REF Control Register

Byte 3	Name	Control Function	Type	0	1	Default
Bit 7	REF	Slew Rate Control	RW	00 = Slowest	01 = Slow	0
Bit 6			RW	10 = Fast	11 = Faster	1
Bit 5	REF Power Down Function	Wake-on-Lan Enable for REF	RW	REF disabled in Power Down	REF runs in Power Down	0
Bit 4	REF OE	REF Output Enable	RW	Disabled	Enabled	1
Bit 3	Reserved					X
Bit 2	Reserved					X
Bit 1	Reserved					X
Bit 0	Reserved					X

Byte 4 is Reserved.

SMBus Table: Revision and Vendor ID Register

Byte 5	Name	Control Function	Type	0	1	Default
Bit 7	RID3	Revision ID	R	C rev = 0010		0
Bit 6	RID2		R			0
Bit 5	RID1		R			1
Bit 4	RID0		R			0
Bit 3	VID3	VENDOR ID	R	0001 = IDT		0
Bit 2	VID2		R			0
Bit 1	VID1		R			0
Bit 0	VID0		R			1

SMBus Table: Device Type/Device ID

Byte 6	Name	Control Function	Type	0	1	Default
Bit 7	Device Type1	Device Type	R	00 = FGx, 01 = DBx, 10 = DMx, 11 = DBx w/oPLL		0
Bit 6	Device Type0		R			0
Bit 5	Device ID5	Device ID	R	00010 binary or 02 hex		0
Bit 4	Device ID4		R			0
Bit 3	Device ID3		R			0
Bit 2	Device ID2		R			0
Bit 1	Device ID1		R			1
Bit 0	Device ID0		R			0

SMBus Table: Byte Count Register

Byte 7	Name	Control Function	Type	0	1	Default
Bit 7	Reserved					X
Bit 6	Reserved					X
Bit 5	Reserved					X
Bit 4	BC4	Byte count programming	RW	Writing to this register will configure how many bytes will be read back, default is = 8 bytes.		0
Bit 3	BC3		RW			1
Bit 2	BC2		RW			0
Bit 1	BC1		RW			0
Bit 0	BC0		RW			0

Bytes 8 and 9 are Reserved.

SMBus Table: PLL MN Enable, PD_Restore

Byte 10	Name	Control Function	Type	0	1	Default
Bit 7	Reserved	Reserve bit, leave at default	RW	Reserved	Reserved	0
Bit 6	Power-Down (PD) Restore	Restore Default Config in PD	RW	Clear Config in PD	Keep Config in PD	1
Bit 5	Reserved					X
Bit 4	Reserved					X
Bit 3	Reserved					X
Bit 2	Reserved					X
Bit 1	Reserved					X
Bit 0	Reserved					X

SMBus Table: Stop State Control

Byte 11	Name	Control Function	Type	0	1	Default
Bit 7	Reserved					X
Bit 6	Reserved					X
Bit 5	Reserved					X
Bit 4	Reserved					X
Bit 3	Reserved					X
Bit 2	Reserved					X
Bit 1	STP[1]	True/Complement DIF Output Disable State	RW	00 = Low/Low	10 = High/Low	0
Bit 0	STP[0]		RW	01 = HiZ/HiZ	11 = Low/High	0

SMBus Table: Impedance Control

Byte 12	Name	Control Function	Type	0	1	Default
Bit 7	DIF0_imp[1]	DIF0 Zout	RW	00 = 33Ω DIF Zout	10 = 100Ω DIF Zout	0
Bit 6	DIF0_imp[0]	DIF0 Zout	RW	01 = 85Ω DIF Zout	11 = Reserved	1
Bit 5	Reserved					X
Bit 4	Reserved					X
Bit 3	Reserved					X
Bit 2	Reserved					X
Bit 1	Reserved					X
Bit 0	Reserved					X

Note: 9FGLxx41 defaults to '10', 9FGLxx51 defaults to '01'

SMBus Table: Impedance Control

Byte 13	Name	Control Function	Type	0	1	Default
Bit 7	Reserved					X
Bit 6	Reserved					X
Bit 5	Reserved					X
Bit 4	Reserved					X
Bit 3	DIF1_imp[1]	DIF1 Zout	RW	00 = 33Ω DIF Zout	10 = 100Ω DIF Zout	0
Bit 2	DIF1_imp[0]	DIF1 Zout	RW	01 = 85Ω DIF Zout	11 = Reserved	1
Bit 1	Reserved					X
Bit 0	Reserved					X

Note: 9FGLxx41 defaults to '10', 9FGLxx51 defaults to '01'

SMBus Table: Pull-up Pull-down Control

Byte 14	Name	Control Function	Type	0	1	Default
Bit 7	OE0_pu/pd[1]	OE0 Pull-up (PuP)/ Pull-down (Pdwn) control	RW	00=None	10 = Pup	0
Bit 6	OE0_pu/pd[0]		RW	01=Pdwn	11 = Pup + Pdwn	1
Bit 5	Reserved					X
Bit 4	Reserved					X
Bit 3	Reserved					X
Bit 2	Reserved					X
Bit 1	Reserved					X
Bit 0	Reserved					X

SMBus Table: Pull-up/Pull-down Control

Byte 15	Name	Control Function	Type	0	1	Default
Bit 7	Reserved					0
Bit 6	Reserved					1
Bit 5	Reserved					0
Bit 4	Reserved					1
Bit 3	OE1_pu/pd[1]	OE0 Pull-up (PuP)/ Pull-down (Pdown) control	RW	00 = None	10 = Pup	0
Bit 2	OE1_pu/pd[0]		RW	01 = Pdown	11 = Pup + Pdown	1
Bit 1	Reserved					0
Bit 0	Reserved					1

SMBus Table: Pull-up/Pull-down Control

Byte 16	Name	Control Function	Type	0	1	Default
Bit 7	Reserved					0
Bit 6	Reserved					0
Bit 5	Reserved					1
Bit 4	Reserved					0
Bit 3	Reserved					0
Bit 2	Reserved					1
Bit 1	CKPWRGD_PD_pu/pd[1]	CKPWRGD_PD Pull-up (PuP)/ Pull-down (Pdown) control	RW	00 = None	10 = Pup	1
Bit 0	CKPWRGD_PD_pu/pd[0]		RW	01 = Pdown	11 = Pup + Pdown	0

Byte 17 is Reserved.

SMBus Table: Polarity Control

Byte 18	Name	Control Function	Type	0	1	Default
Bit 7	Reserved					0
Bit 6	Reserved					0
Bit 5	OE1_polarity	Sets OE1 polarity	RW	Enabled when Low	Enabled when High	0
Bit 4	Reserved					0
Bit 3	OE0_polarity	Sets OE0 polarity	RW	Enabled when Low	Enabled when High	0
Bit 2	Reserved					0
Bit 1	Reserved					0
Bit 0	Reserved					0

SMBus Table: Polarity Control

Byte 19	Name	Control Function	Type	0	1	Default
Bit 7	Reserved					0
Bit 6	Reserved					0
Bit 5	Reserved					0
Bit 4	Reserved					0
Bit 3	Reserved					0
Bit 2	Reserved					0
Bit 1	Reserved					0
Bit 0	CKPWRGD_PD	Determines CKPWRGD_PD polarity	RW	Power Down when Low	Power Down when High	0

Package Outline Drawings

The package outline drawings are appended at the end of this document and are accessible from the link below. The package information is the most current data available.

www.idt.com/document/psc/nlnlg24p1-package-outline-40-x-40-mm-body-05-mm-pitch-qfn-epad-size-245-x-245-mm

Marking Diagrams

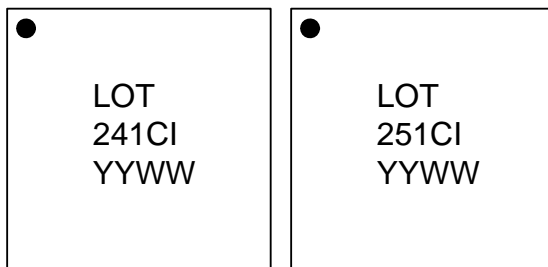

1. "LOT" denotes sequential lot number.
2. Line 2 is the truncated part number.
3. "YYWW" is the last digit of the year and week that the part was assembled.

Ordering Information

Table 18. Ordering Information

Orderable Part Number	Package	Carrier Type	Temperature	Output Zo
9FGL0241CKILF	4 × 4 mm, 0.5mm pitch 24-VFQFPN	Trays	-40° to +85°C	100Ω
9FGL0241CKILFT	4 × 4 mm, 0.5mm pitch 24-VFQFPN	Reel	-40° to +85°C	100Ω
9FGL0251CKILF	4 × 4 mm, 0.5mm pitch 24-VFQFPN	Trays	-40° to +85°C	85Ω
9FGL0251CKILFT	4 × 4 mm, 0.5mm pitch 24-VFQFPN	Reel	-40° to +85°C	85Ω

"LF" denotes Pb-free configuration, RoHS compliant.

"C" is the device revision designator (will not correlate with the datasheet revision)

Revision History

Revision Date	Description of Change
September 12, 2018	Initial release.



Corporate Headquarters
6024 Silver Creek Valley Road
San Jose, CA 95138 USA
www.IDT.com

Sales
1-800-345-7015 or 408-284-8200
Fax: 408-284-2775
www.IDT.com/go/sales

Tech Support
www.IDT.com/go/support

DISCLAIMER Integrated Device Technology, Inc. (IDT) and its affiliated companies (herein referred to as "IDT") reserve the right to modify the products and/or specifications described herein at any time, without notice, at IDT's sole discretion. Performance specifications and operating parameters of the described products are determined in an independent state and are not guaranteed to perform the same way when installed in customer products. The information contained herein is provided without representation or warranty of any kind, whether express or implied, including, but not limited to, the suitability of IDT's products for any particular purpose, an implied warranty of merchantability, or non-infringement of the intellectual property rights of others. This document is presented only as a guide and does not convey any license under intellectual property rights of IDT or any third parties.

IDT's products are not intended for use in applications involving extreme environmental conditions or in life support systems or similar devices where the failure or malfunction of an IDT product can be reasonably expected to significantly affect the health or safety of users. Anyone using an IDT product in such a manner does so at their own risk, absent an express, written agreement by IDT.

Integrated Device Technology, IDT and the IDT logo are trademarks or registered trademarks of IDT and its subsidiaries in the United States and other countries. Other trademarks used herein are the property of IDT or their respective third party owners. For datasheet type definitions and a glossary of common terms, visit www.idt.com/go/glossary. Integrated Device Technology, Inc. All rights reserved.