

Doc. Version	0.1
Total Pages	31
Date	2008/05/19

Product Specification

3.0" COLOR TFT-LCD MODULE

MODEL NAME: A030FL01 V1

< >Preliminary Specification

<◆>Final Specification

© 2008 AU Optronics
All Rights Reserved.

DO NOT COPY

Note: The content of this specification is subject to change.

Record of Revision

Version	Revise Date	Page	Content
0.0	08/Oct/2007		First draft.
0.0a	16/Oct/2007	4	Mark pin 1, pin 71 on FPC golden pin.
0.1	19/May/2007	5	Add Connetor Type

Contents

GENERAL DESCRIPTION	2
FEATURES	2
1. GENERAL INFORMATION	3
2. ELECTRICAL SPECIFICATIONS	5
2.1 FPC PIN ASSIGNMENT	5
2.2 ABSOLUTE MAXIMUM RATINGS	8
3. ELECTRICAL CHARACTERISTICS	8
3.1 TFT- LCD TYPICAL OPERATION CONDITION	8
3.2 BACKLIGHT DRIVING CONDITIONS	9
3.3 SUGGESTED APPLICATION CIRCUIT	10
3.3.1 SUGGESTED APPLICATION CIRCUIT	10
3.3.2 SUGGESTED APPLICATION CIRCUIT	11
3.4 AC TIMING	12
3.4.1 TIMING DIAGRAM	12
3.4.2 TIMING CONDITION	13
3.5 POWER ON/OFF SEQUENCE	13
3.5.1 POWER-ON (DISPLAY ON; STANDBY DISABLING)	13
3.5.2 POWER-OFF (DISPLAY OFF; STANDBY ENABLING)	15
3.5.3 LOW-VOLTAGE RESET	16
3.6 SERIAL CONTROL SETTING	17
3.6.1 INPUT TIMING SPECIFICATIONS (REFER TO FIG. 1)	17
3.6.2 SERIAL SETTING TABLE	18
4. OPTICAL SPECIFICATIONN	28
5. ABSOLUTE RATINGS OF AMBIENT ENVIRONMENT	30
6. PACKING FORM	31

General Description

A030FL01 V1 is a color TFT (Thin Film Transistor) LCD (Liquid crystal Display). This model is composed of TFT-LCD, drive IC, FPC (flexible printed circuit), backlight unit.

Features

- 3-inch display size
- QQHDTV resolution and wide aspect ratio
- 16.7M colors
- System Integration
 - Timing controller
 - Charge pump for VGH, VGL
 - 2-in-1 FPC
 - B-to-B Connector
- SYNC input mode
- Parallel digital 8-bit data interface
- ATR-MVA (Advanced TRansflective – Multi-domain Vertical Alignment)
 - Wide view angle
 - No Gray Scale Inversion
 - Sunlight readable
 - High contrast ratio
- Green design

1. General Information

NO.	Item	Unit	Specification	Remark
1	Display Resolution	dot	480RGB(H)x272(V)	
2	Active Area	mm	65.52(H)x37.128(V)	
3	Screen Size	inch	3.0" (Diagonal)	
4	Dot Pitch	mm	0.0455(H)x0.1365(V)	
5	Color Configuration	--	R. G. B. Stripe	Note 1
6	Color Depth	--	16.7M Colors	Note 2
7	Overall Dimension	mm	76.12(H) × 43.8(V) × 2.5(T)	Note 3
8	Weight	g	18.8 (Typical)	
9	Display Mode	--	Normally Black	

Note 1: Below figure shows dot stripe arrangement.

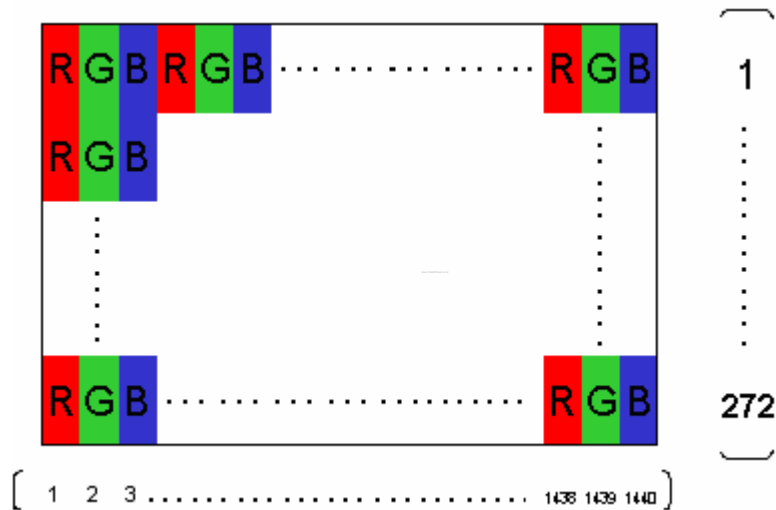

Note 2: The full color display depends on 8-bit data signal (pin9~34).

Note 3: Not include FPC. Refer next page to get further information.

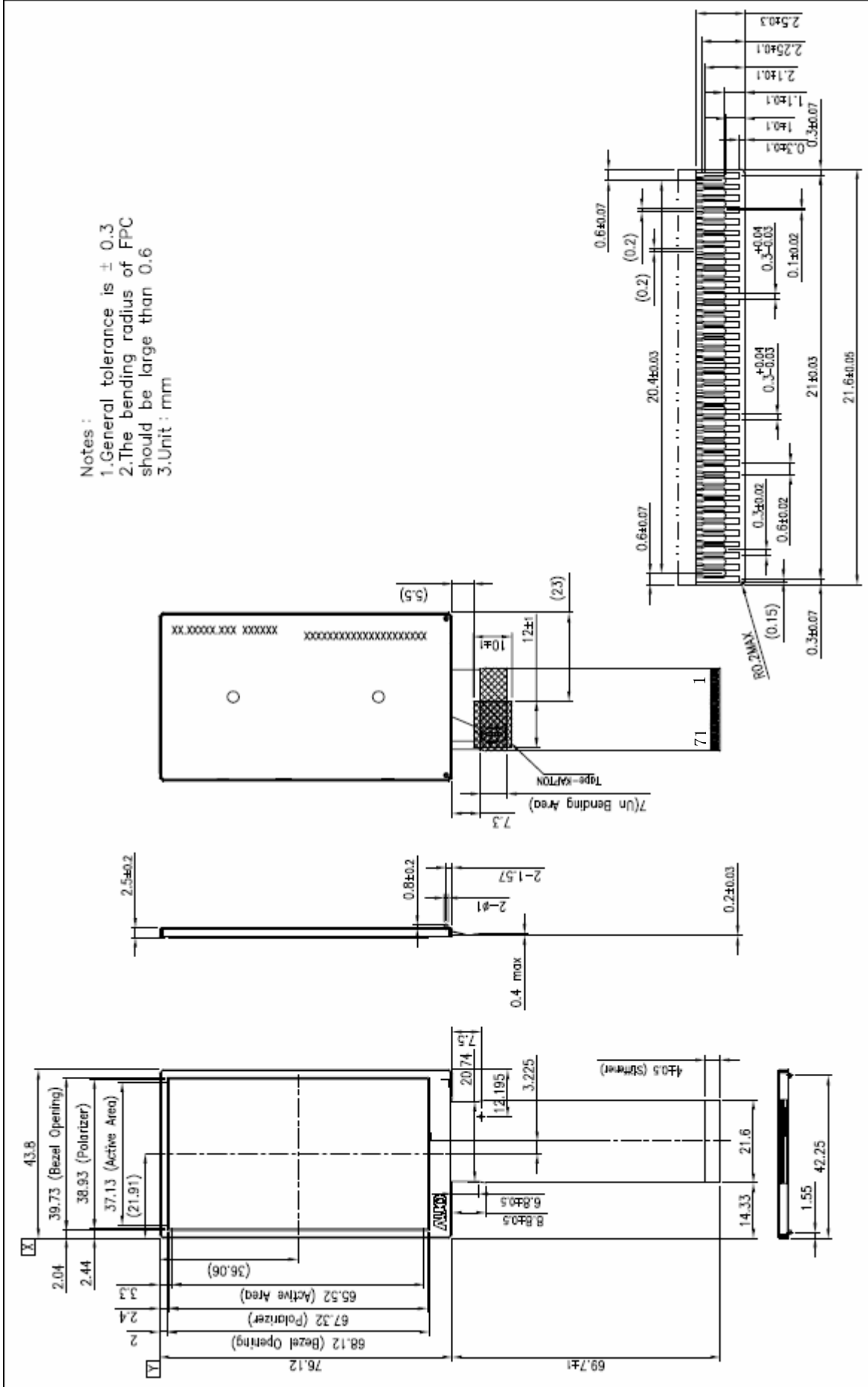

Outline Dimension of A030FL01 V1 Module

2. Electrical Specifications

2.1 FPC Pin Assignment

Connector: FH26-71S-0.3SHW(05)

Pin no	Symbol	Type	Description	Remark
1	VCOM	I	Common voltage	
2	FRP	O	Frame polarity	
3	VCOML	P	Power Setting Capacitor for VCOM	
4	VCOMH	P	Power Setting Capacitor for VCOM	
5	VGL	P	Power setting capacitor	
6	VGH	P	Power setting capacitor	
7	VLOUT2	P	Power setting capacitor	
8	V12	P	Connect capacitor for power circuit	
9	V11	P	Connect capacitor for power circuit	
10	V10	P	Connect capacitor for power circuit	
11	V9	P	Connect capacitor for power circuit	
12	V8	P	Connect capacitor for power circuit	
13	V7	P	Connect capacitor for power circuit	
14	VLOUT3	P	Power setting capacitor	
15	VCL	P	Power setting capacitor	
16	VDD3	P	Power setting capacitor	
17	V6	P	Connect capacitor for power circuit	
18	V5	P	Connect capacitor for power circuit	
19	V4	P	Connect capacitor for power circuit	
20	V3	P	Connect capacitor for power circuit	
21	V2	P	Connect capacitor for power circuit	
22	V1	P	Connect capacitor for power circuit	
23	VDD2	P	Power setting capacitor	
24	VDDA	P	Power setting capacitor	
25	GND	P	Ground	

Pin no	Symbol	Type	Description	Remark
26	GND	P	Ground	
27	VDD	P	Power supply for charge pump	
28	VDD	P	Power supply for charge pump	
29	VDDIO	P	Power supply for digital interface	
30	VDD_25V	P	Power setting capacitor	
31	R0	I	Red data (LSB)	
32	R1	I	Red data	
33	R2	I	Red data	
34	R3	I	Red data	
35	R4	I	Red data	
36	R5	I	Red data	
37	R6	I	Red data	
38	R7	I	Red data (MSB)	
39	NC	-	Dummy pin	N/A
40	G0	I	Green data (LSB)	
41	G1	I	Green data	
42	G2	I	Green data	
43	G3	I	Green data	
44	G4	I	Green data	
45	G5	I	Green data	
46	G6	I	Green data	
47	G7	I	Green data (MSB)	
48	NC	-	Dummy pin	N/A
49	B0	I	Blue data (LSB)	
50	B1	I	Blue data	

Pin no	Symbol	Type	Description	Remark
51	B2	I	Blue data	
52	B3	I	Blue data	
53	B4	I	Blue data	
54	B5	I	Blue data	
55	B6	I	Blue data	
56	B7	I	Blue data (MSB)	
57	GND	P	Ground	
58	DCLK	I	Pixel clock	
59	GRB	I	Global Reset	
60	HSYNC	I	Horizontal Sync Signal	
61	VSYNC	I	Vertical Sync Signal	
62	SCL	I	Serial command clock input	
63	SDA	I/O	Serial command data input	
64	CS	I	Serial command enable signal	
65	VLED+	P	LED anode	
66	VLED-	P	LED cathode	
67	DRV	O	VLED boost transistor driving signal	
68	VCOM	I	Common voltage	
69	NC	-	Dummy pin	N/A
70	NC	-	Dummy pin	N/A
71	NC	-	Dummy pin	N/A

Note 1: I: Input; O: Output; P: Power.

2.2 Absolute Maximum Ratings

Item	Symbol	Condition	Min.	Max.	Unit	Remark
Power voltage	VDD	GND=0	-0.3	4.5	V	Note 1
	VDDIO	GND=0	-0.3	4.5	V	Note 1
Operating temperature	Topa	—	0	60	°C	Ambient temperature
Storage temperature	Tstg	—	-25	80	°C	Ambient temperature

Note 1: Functional operation should be restricted under normal ambient temperature.

3. Electrical Characteristics

The following items are measured under stable condition and suggested application circuit.

3.1 TFT- LCD Typical Operation Condition

Item	Symbol	Min.	Typ.	Max.	Unit	Remark
Power supply	VDD	3.1	3.3	3.5	V	
	VDDIO	1.65	3.3	3.5	V	
Vsync Frequency	f_V		60		Hz	
Hsync Frequency	f_H		17.16		KHz	
Main Frequency	f_{DCLK}		9.0	10.0	MHz	

Note 1: Above every operation range is based on stable operation from suggested application circuit 3.3.1.

Note 2: A built-in power-on reset circuit for VDD and VDDIO is provided within the integrated LCD driver IC. The LCD module is in default in power save mode, and a standby releasing is required after VDDIO power on through serial control interface. Please refer to the serial control interface for detail.

Note 3: The power supply of digital interface, VDDIO, is for the 1.8V digital interface requirement in the future. These digital signals are DCLK, HSYNC, VSYNC, R7~R0, G7~G0, B7~B0. If the digital interface is in the level of 3.3V, please short the power pin, VDD and

VDDIO, to 3.3V. In other words, no matter the voltage level of VDDIO is 1.65V or 3.5V, the voltage level of VDD needs to be kept around 3.3V.

3.2 Backlight Driving Conditions

Parameter	Symbol	Min.	Typ.	Max.	Unit	Remark
LED Current	I_L	---	20	25	mA	single seral
LED Voltage	V_L	---	12.8	---	V	single seral
LED Life Time	L_L	10,000	---	---	Hr	Note 2, 3

Note 1: LED backlight is four LEDs serial type.

Note 2 :Define “LED Lifetime”: brightness is decreased to 50% of the initial value. LED Lifetime is restricted under normal condition, ambient temperature = 25°C and LED current = 20mA.

Note 3: If it uses larger LED current I_L more than 20mA, it maybe decreases the LED lifetime.

3.3 Suggested Application Circuit

3.3.1 Suggested Application Circuit

(VCOM DC adjusted by variable resistance)

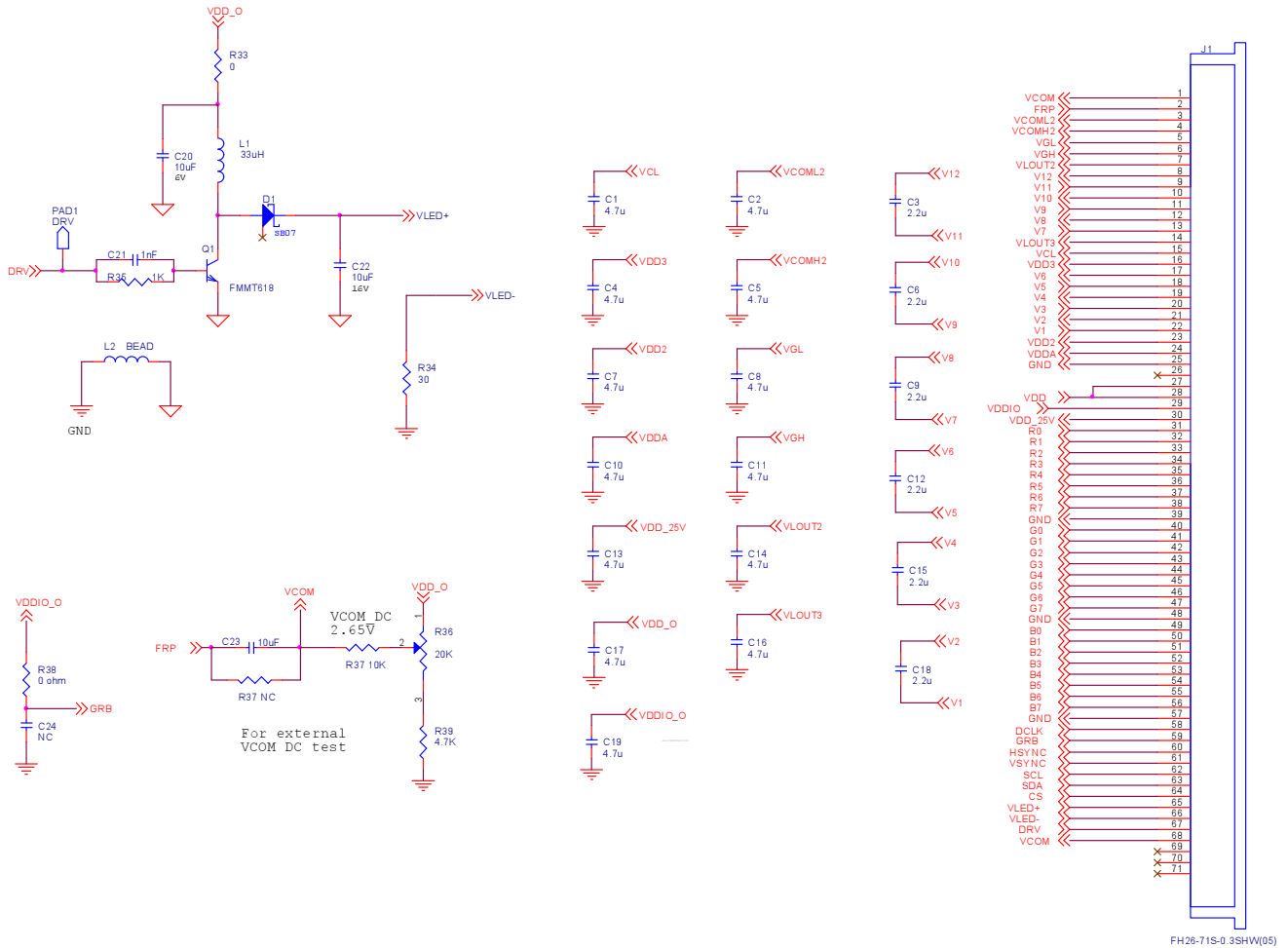

3.3.2 Suggested Application Circuit (VCOM DC adjusted by serial control interface)

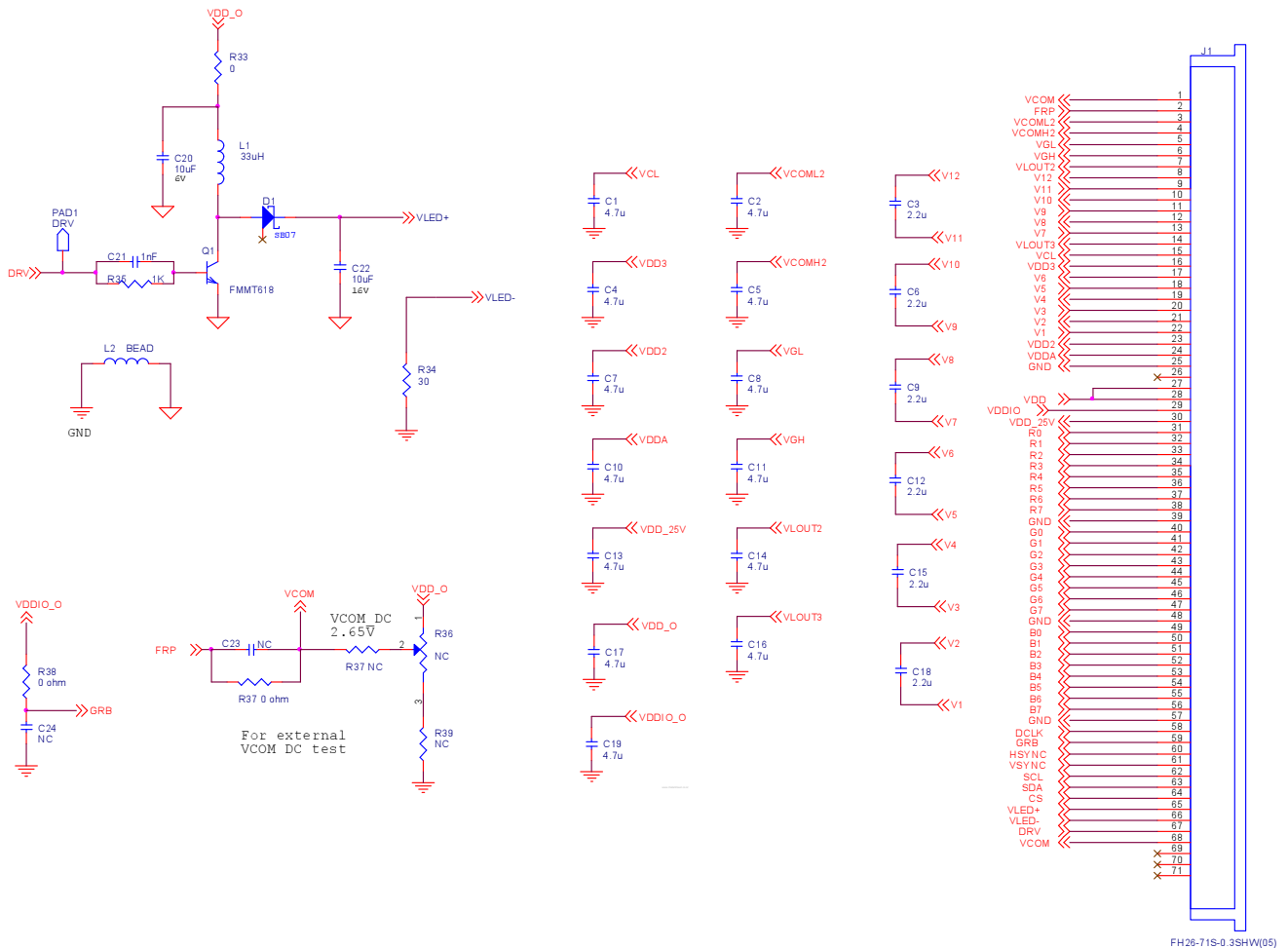

3.4 AC Timing

3.4.1 Timing Diagram

3.4.1.1 Vertical Timing of Input

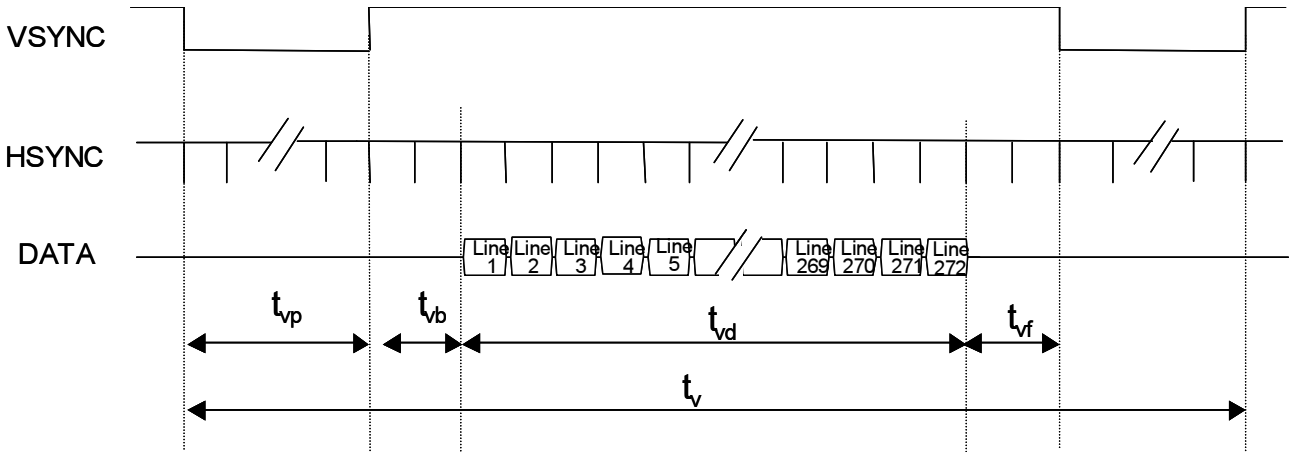

3.4.1.2 Horizontal Timing of Input

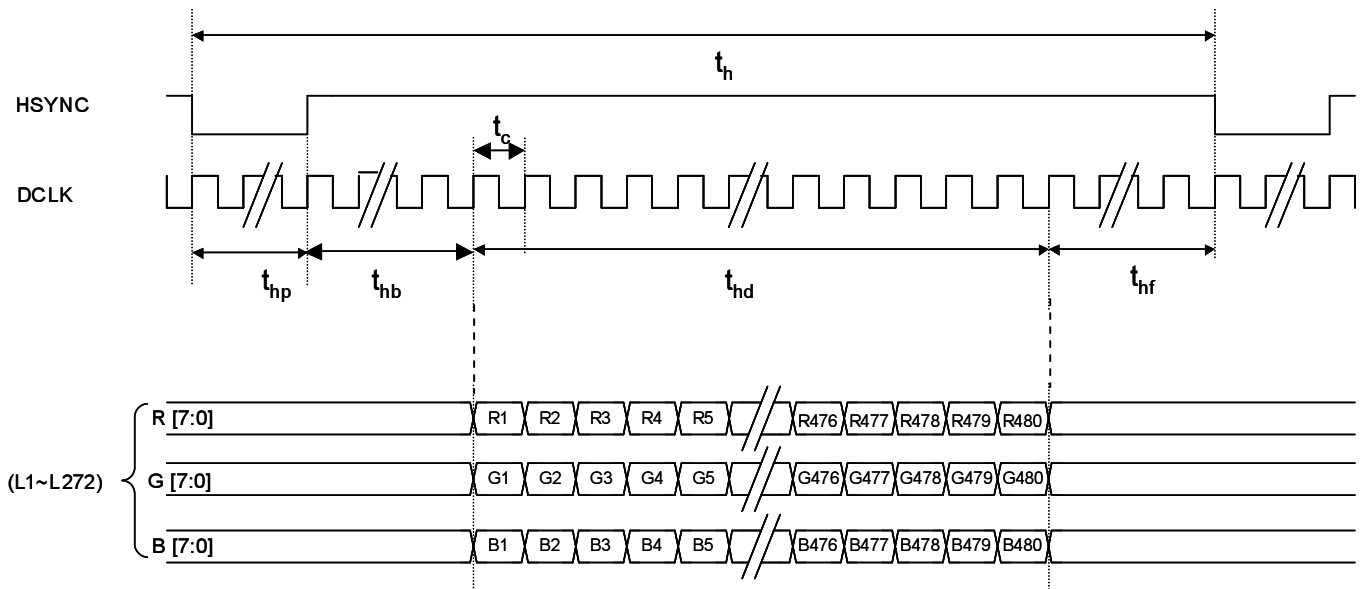

3.4.2 Timing Condition

3.4.2.1. Timing Parameters

Parameter		Symbol	Min.	Typ.	Max.	Unit.	Remark
Clock	Frequency	1/Tc	--	9.2	10	MHz	
	High Time	TCH	40	--	--	ns	
	Low Time	TCL	40	--	--	ns	
Data	Setup Time	TDS	10	--	--	ns	
	Hold Time	TDH	3	--	--	ns	
DE	Setup Time	TDES	10	--	--	ns	
	Hold Time	TDEH	3	--	--	ns	
Frame Frequency	Cycle	tv		16.7		ms	
1 Frame Scanning Time	Cycle	tv	--	288	--	H	
	Display Period	tvd	272			H	
	Front porch	tvf	2	4		H	
	Pulse width	tvp	1	10		H	
	Back porch	tvb	2	2		H	
1 Line Scanning Time	Cycle	th	494	533	545	DCLK	
	Display Period	thd	480			DCLK	
	Front porch	thf	2	8		DCLK	
	Pulse width	thp	1	41		DCLK	
	Back porch	thb	2	4		DCLK	

3.5 Power On/Off Sequence

The register DISP setting of standby mode disabling / enabling is used to control the build-in power on / off sequence.

3.5.1 Power-On (Display ON; Standby Disabling)

The LCD driver is in default standby mode after VDD/VDDIO power-on, and set the register DISP to high to disable the standby mode is required for normal operation. When the standby mode is disabled, a build-in power on sequence is started. The driver IC analog power VDD2 is turned on first, and then the LCD positive and negative power supplies VGH/VGL are pumped, and followed by the LED power. Since we recommend using external LED driver, the backlight power should be provided at this time. Please refer to power on sequence for the detail timing.

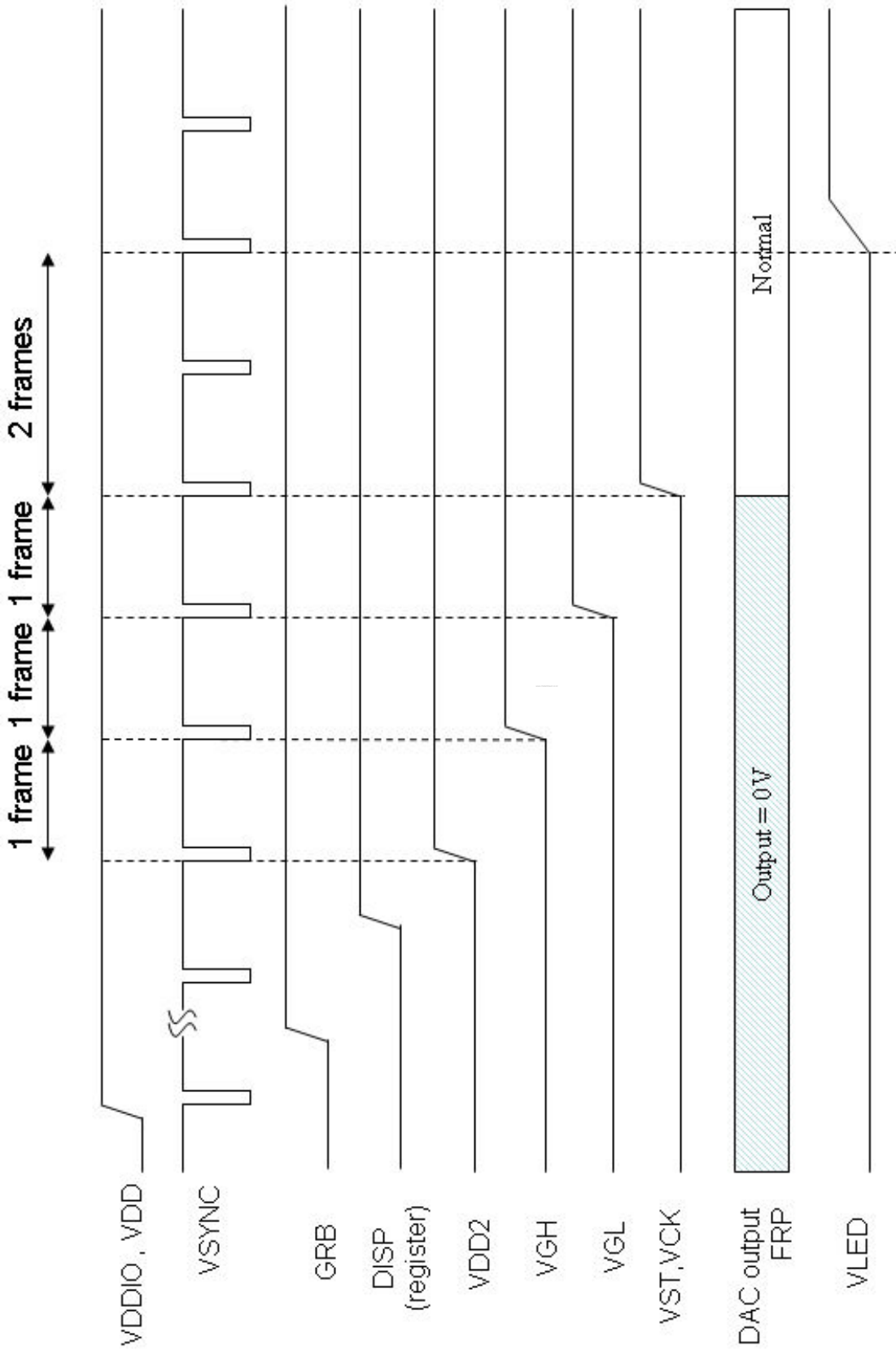

Power-ON Sequence

3.5.2 Power-Off (Display Off; Standby Enabling)

When the register DISP is set to low to enable standby mode, a build-in power off sequence is started. Please also refer to the power off sequence for the detail timing.

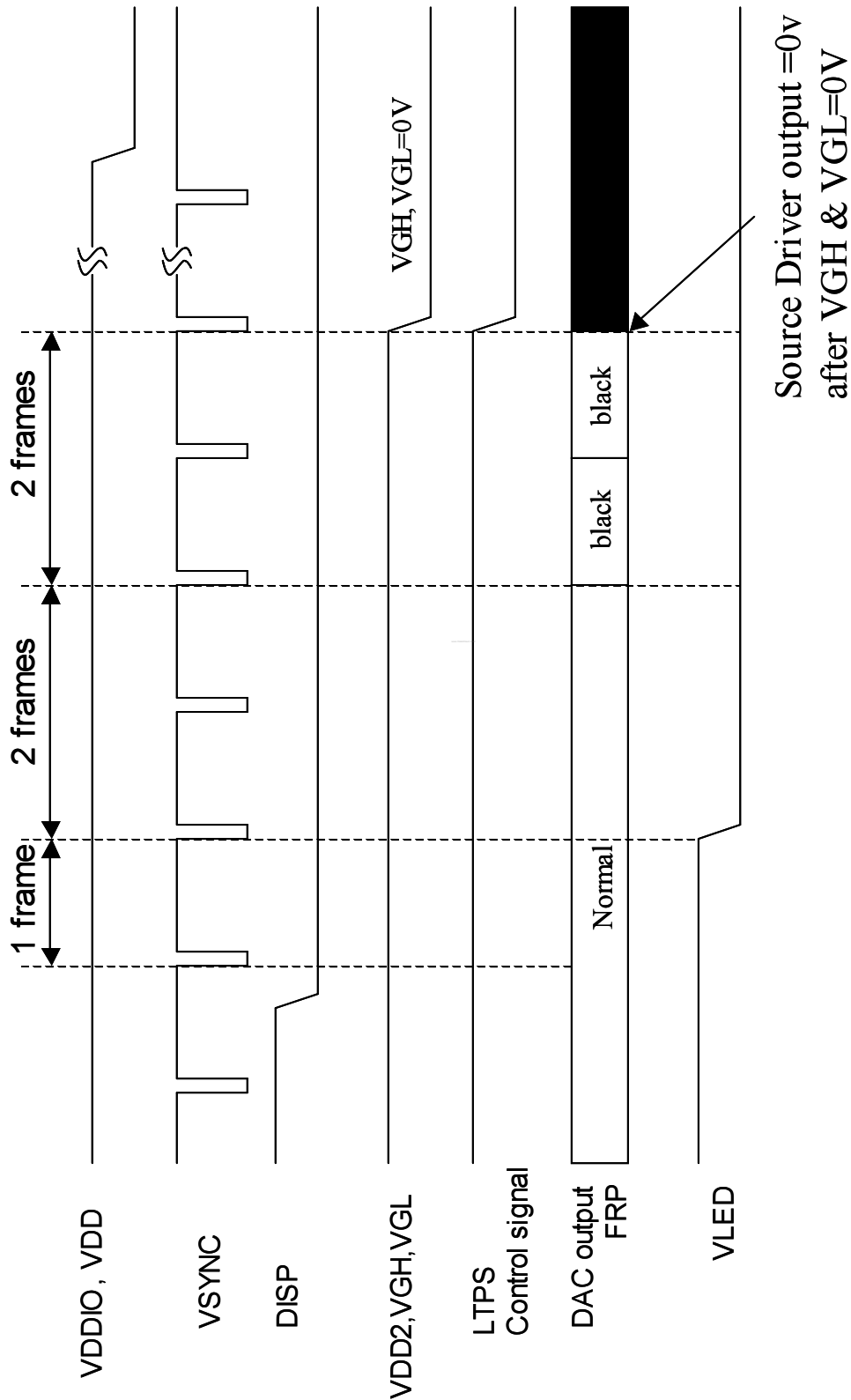

Power-OFF Sequence

3.5.3 Low-voltage Reset

Following figure suggests for low voltage reset function on power on sequence. When low voltage reset function enable, all the registers are loaded to default setting.

- A. The rising time (10%-90%) of VDD needs larger than 1ms.
- B. After power off, VDD needs to be keep under 0.5V more than 500ms, then it can be power on again.

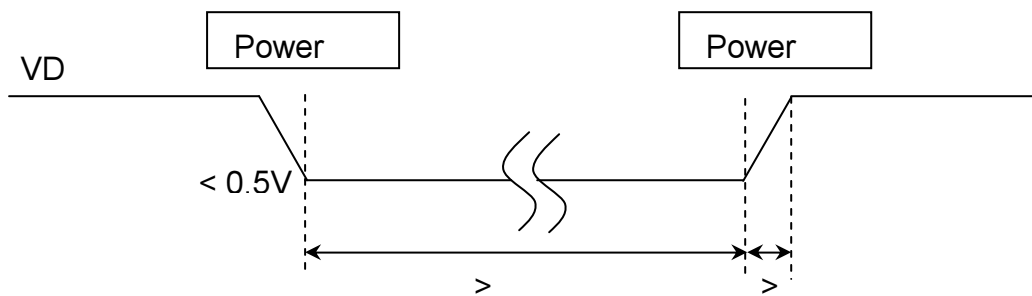

3.6 Serial Control Setting

3.6.1 Input timing specifications (refer to Fig. 1)

Parameter	Symbol	Min.	Typ.	Max.	Unit.	Remark
Serial load input setup time	t_{s0}	50			ns	
Serial load input hold time	t_{h0}	50			ns	
Serial data input setup time	t_{s1}	50			ns	
Serial data input hold time	t_{h1}	50			ns	
SCL pulse width	t_{WL1}	50			ns	
	t_{WH1}	50			ns	
CS pulse width	t_{W2}	400			ns	

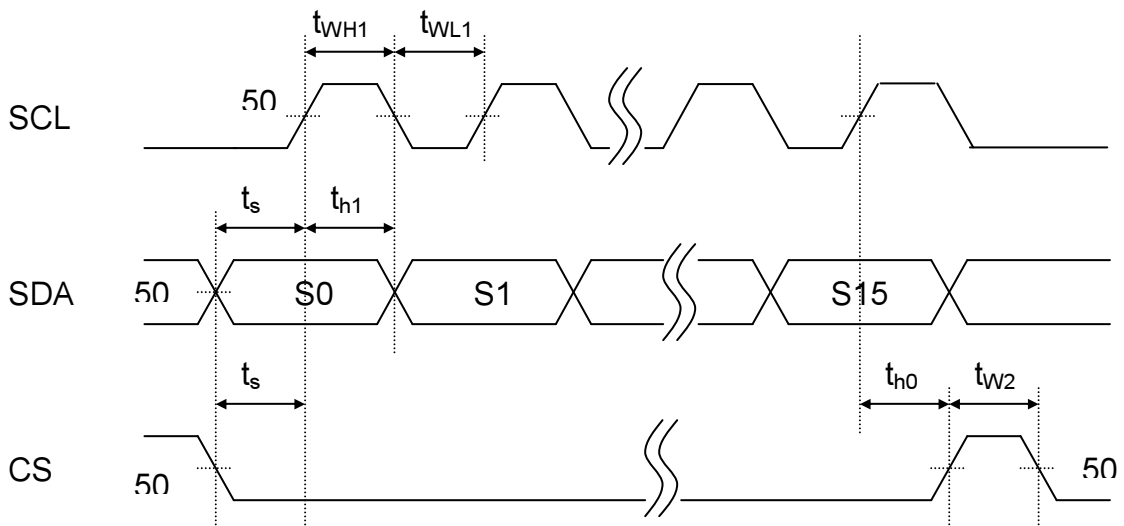
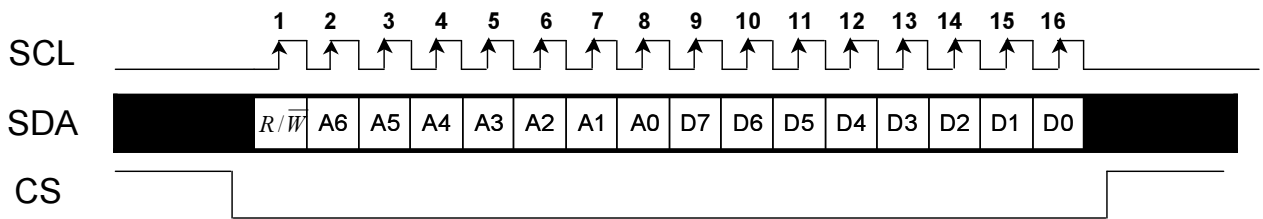

Fig.1 Serial Interface Control Timing

3.6.2 Serial setting table

No	Register Address								Register Data (Default Setting)							
	R/ \bar{W}	A6	A5	A4	A3	A2	A1	A0	D7	D6	D5	D4	D3	D2	D1	D0
R0	0	0	0	0	0	0	0	0	X	VDIR(1)	HDIR(1)	0	VCOM_AC(0110)			
R1	0	0	0	0	0	0	0	1	0	VCOM_DC(40h)						
R2	0	0	0	0	0	0	1	0	CONTRAST(40h)							
R3	0	0	0	0	0	0	1	1	X	SUB-CONTRAST_R(40h)						
R4	0	0	0	0	0	1	0	0	X	SUB-CONTRAST_B(40h)						
R5	0	0	0	0	0	1	0	1	BRIGHTNESS(40h)							
R6	0	0	0	0	0	1	1	0	X	SUB-BRIGHTNESS_R(40h)						
R7	0	0	0	0	0	1	1	1	X	SUB-BRIGHTNESS_B(40h)						
R8	0	0	0	0	1	0	0	0	HSYNC BLANKING(2Bh)							
R9	0	0	0	0	1	0	0	1	Vdpol(1)	Hdpol(1)	VSYNC BLANKING(0Ch)					
R10	0	0	0	0	1	0	1	0	1	DCLKpol(1)	0	0	1	0	1	0
R11	0	0	0	0	1	0	1	1	LED_CURRENT(00)		BL_DRV(00)		DRV_FREQ(00)		PFM_DUTY(10)	
R12	0	0	0	0	1	1	0	0	LED_ON_CYCLE(0111)				LED_ON_RATIO(1111)			
R13	0	0	0	0	1	1	0	1	X	1	X	X	GRB(1)	1	SHDB1(0)	DISP(0)
R64	0	1	0	0	0	0	0	0	1	1	0 X	00		00		
R66	0	1	0	0	0	0	1	0	X	43h						
R68	0	1	0	0	0	1	0	0	X	28h						

Note: X is "don't care". " " could be registered by customer.

Register R0

Register	R/ \bar{W}	Address	D7	D6	D5	D4	D3	D2	D1	D0
R0	0	00h	X	VDIR	HDIR	0	VCOM_AC			

VCOM_AC : Common voltage AC level selection (deviation $\pm 0.1V$)

VCOM_AC				Voltage (V)
D3	D2	D1	D0	
0	0	0	0	5.8
0	0	0	1	5.9
0	0	1	0	6.0
0	0	1	1	6.1
0	1	0	0	6.2
0	1	0	1	6.3
0	1	1	0	6.4 (Default)
0	1	1	1	6.5
1	0	0	0	6.6
1	0	0	1	6.7
1	0	1	0	6.8
1	0	1	1	6.9
1	1	X	X	7.0

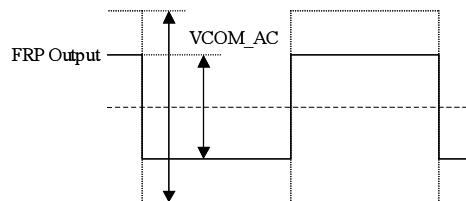

Register	R/ \bar{W}	Address	D7	D6	D5	D4	D3	D2	D1	D0
R0	0	00h	X	VDIR	HDIR	0	VCOM_AC			

HDIR : Horizontal shift direction setting

HDIR	Description
0	Shift from right to left, ex : Last data = Y1←Y2...Y1439←Y1440 = First data
1	Shift from left to right, ex : First data = Y1→Y2...Y1439→Y1440 = Last data (Default)

VDIR : Vertical shift direction setting

VDIR	Description
0	Shift from down to up, ex : Last line = L1←L2...L271←L272 = First line
1	Shift from up to down, ex : First line = L1→L2...L271→L272 = Last line (Default)

Register R1

Register	R/ \bar{W}	Address	D7	D6	D5	D4	D3	D2	D1	D0
R1	0	01h	0	VCOM_DC						

VCOM_DC : Common voltage DC level selection

VCOM_DC	Voltage (V)
D6~D0	
00h	2
:	:
40h	2.605 (Default)
:	:
7Fh	3.2

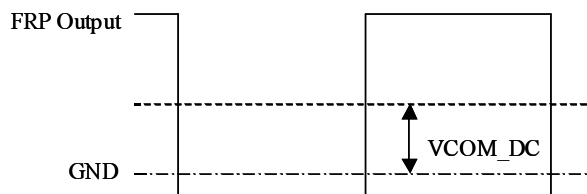

Register R2, R3, R4, R5, R6, R7

Register	R/ \bar{W}	Address	D7	D6	D5	D4	D3	D2	D1	D0
R2	0	02h	CONTRAST							

CONTRAST : RGB contrast level setting, the gain changes (1/64) / bit

CONTRAST	Gain
D7~D0	
00h	0
40h	1 (Default)
FFh	3.984

Register	R/ \bar{W}	Address	D7	D6	D5	D4	D3	D2	D1	D0
R3	0	03h	X	SUB-CONTRAST_R						

Register	R/ \bar{W}	Address	D7	D6	D5	D4	D3	D2	D1	D0
R4	0	04h	X	SUB-CONTRAST_B						

SUB-CONTRAST_RB : RB sub-contrast level setting, the gain changes (1/256) / bit

SUB-CONTRAST	Gain
D6~D0	
00h	0.75
40h	1 (Default)
7Fh	1.246

Register	R/ \bar{W}	Address	D7	D6	D5	D4	D3	D2	D1	D0
R5	0	05h	BRIGHTNESS							

BRIGHTNESS : RGB bright level setting, setting accuracy : 1 step / bit

BRIGHTNESS	Setting
D7~D0	
00h	Dark (-64)
40h	Center (0) (Default)
FFh	Bright (+191)

Register	R/ \bar{W}	Address	D7	D6	D5	D4	D3	D2	D1	D0
R6	0	06h	X	SUB-BRIGHTNESS_R						

Register	R/ \bar{W}	Address	D7	D6	D5	D4	D3	D2	D1	D0
R7	0	07h	X	SUB-BRIGHTNESS_B						

SUB-BRIGHTNESS_RB : RB sub-brightness level setting, setting accuracy : 1 step / bit

SUB-BRIGHTNESS	Setting
D6~D0	
00h	Dark (-64)
40h	Center (0) (Default)
7Fh	Bright (+63)

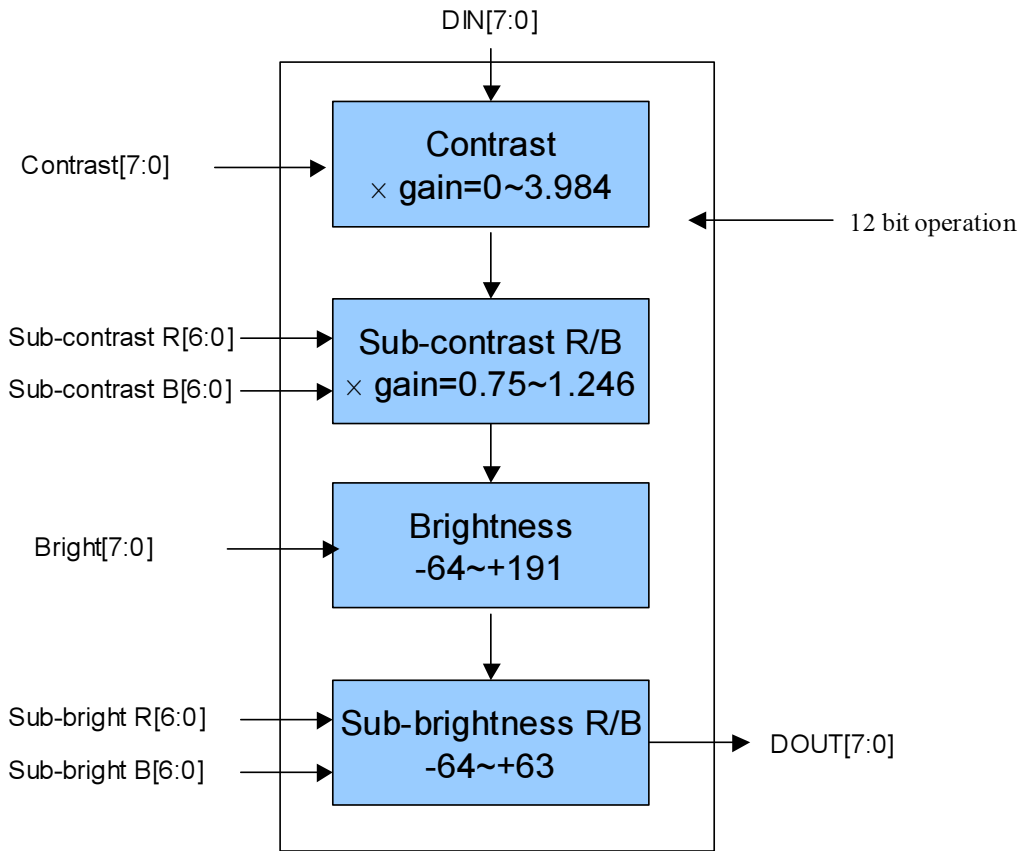

Register	R/ \bar{W}	Address	D7	D6	D5	D4	D3	D2	D1	D0
R8	0	08h	HSYNC BLANKING							

HSYNC BLANKING : Horizontal blanking setting

HSYNC BLANKING		DCLK
D7~D0		
00h		0
2Bh		43 (Default)
FFh		255

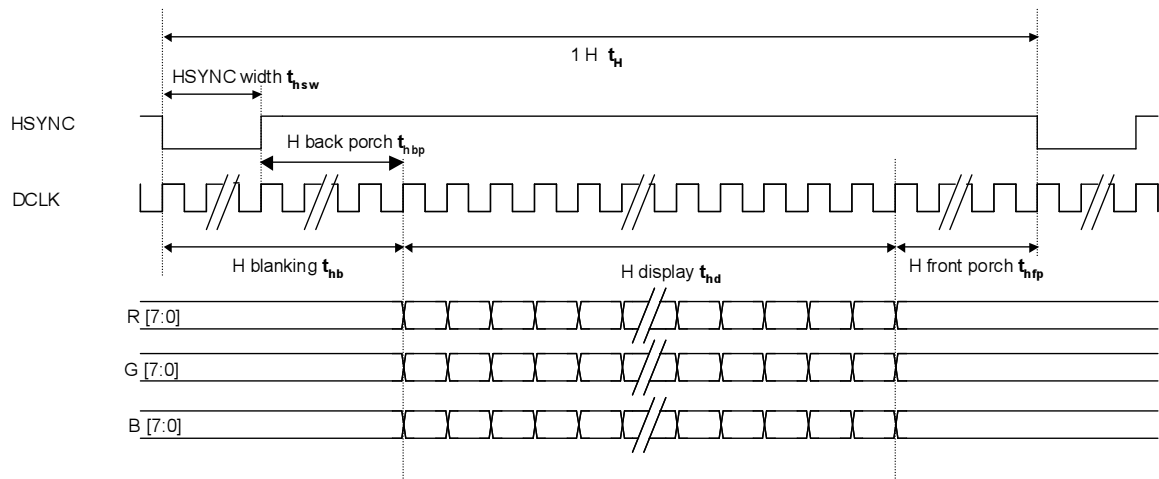

Register	R/ \bar{W}	Address	D7	D6	D5	D4	D3	D2	D1	D0
R9	0	09h	VDPOL	HDPOL	VSYNC BLANKING					

VSYNC BLANKING : Vertical blanking setting

VSYNC BLANKING	H
D5~D0	H
00h	0
0Ch	12 (Default)
3Fh	63

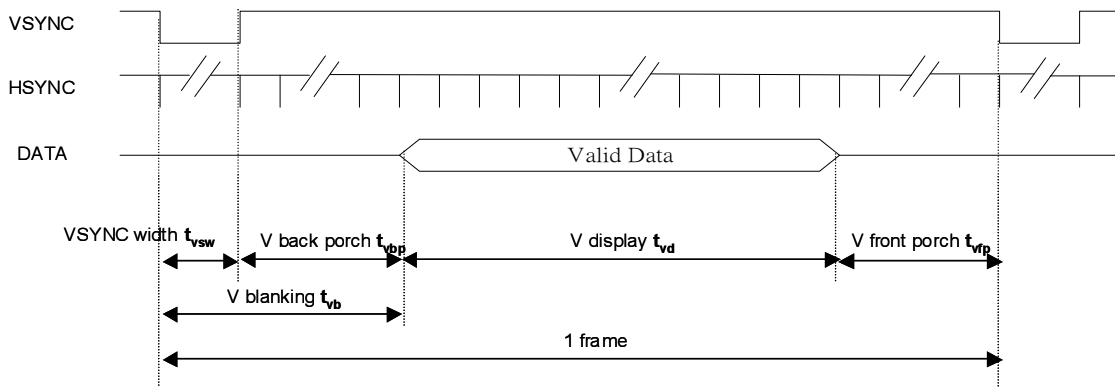

Register	R/ \bar{W}	Address	D7	D6	D5	D4	D3	D2	D1	D0
R9	0	09h	VDPOL	HDPOL	VSYNC BLANKING					

HDPOL : HSYNC polarity selection

HDPOL	Function
0	Positive polarity
1	Negative polarity (Default)

VDPOL : VSYNC polarity selection

VDPOL	Function
0	Positive polarity
1	Negative polarity (Default)

Register	R/ \bar{W}	Address	D7	D6	D5	D4	D3	D2	D1	D0
R10	0	0Ah	1	DCLKPOL	0	0	1	0	1	0

DCLKPOL : DCLK polarity selection

DCLKPOL	Description
0	Positive polarity
1	Negative polarity (Default)

When the command is sent to ASIC, it will be executed immediately.

• HDPOL=1, VDPOL=1, CLKPOL=1

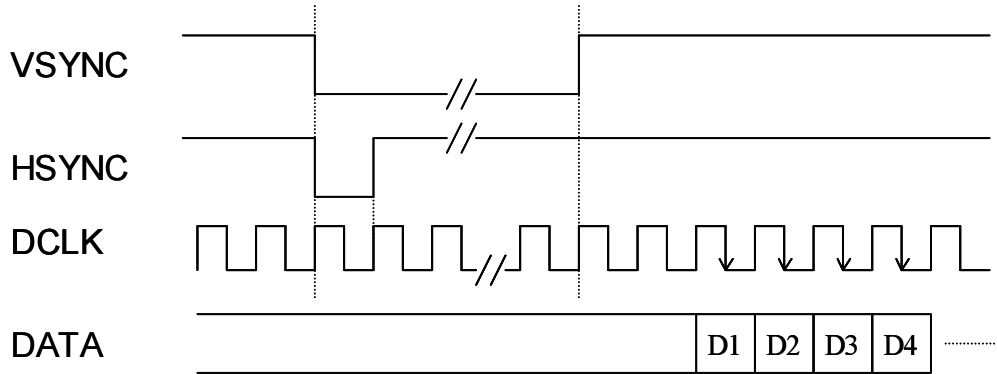

• HDPOL=0, VDPOL=0, CLKPOL=0

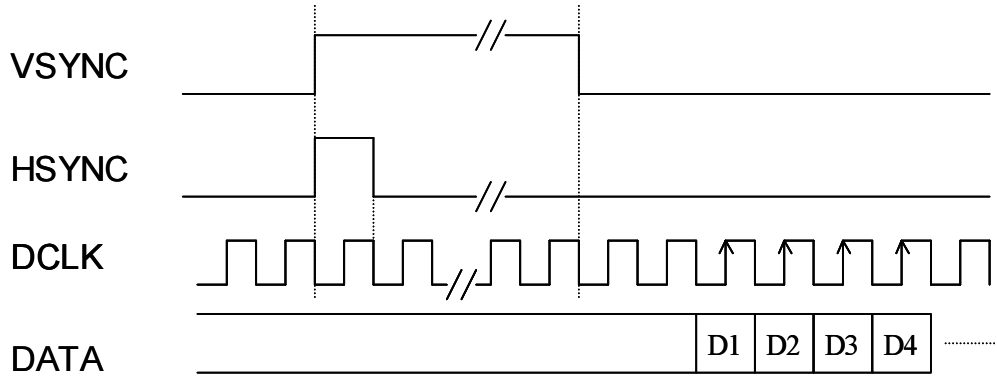

Register	R/ \bar{W}	Address	D7	D6	D5	D4	D3	D2	D1	D0
R11	0	0Bh	LED_CURRENT		BL_DRV		DRV_FREQ		PFM_DUTY	

PFM_DUTY : PFM duty cycle selection for back light power converter

PFM_DUTY		PFM duty cycle	Note
D1	D0		
0	0	50 %	16/32
0	1	60 %	19/32
1	0	65 % (Default)	21/32
1	1	70 %	22/32

DRV_FREQ : DRV signal frequency setting

DRV_FREQ		Frequency
D3	D2	
0	0	DCLK / 32 (Default)
0	1	DCLK / 64
1	0	DCLK / 128
1	1	DCLK / 256

Register	R/ \bar{W}	Address	D7	D6	D5	D4	D3	D2	D1	D0
R11	0	0Bh	LED_CURRENT		BL_DRV		DRV_FREQ		PFM_DUTY	

BL_DRV : Backlight driving capability setting

BL_DRV		Capability
D5	D4	
0	0	Normal capability (Default)
0	1	4 times the Normal capability
1	0	8 times the Normal capability
1	1	12 times the Normal capability

LED_CURRENT : adjust LED current

LED_CURRENT		DC-DC Feedback Voltage
D7	D6	
0	0	0.6 V (default, 20mA)
0	1	0.75V (25mA)
1	0	0.45V (15mA)
1	1	0.3V (10mA)

Register	R/ \bar{W}	Address	D7	D6	D5	D4	D3	D2	D1	D0
R12	0	0Ch	LED_ON_CYCLE				LED_ON_RATIO			

LED_ON_RATIO : Set the active ratio of enable signal, and we can use it to decrease the brightness of the LEDs.

LED_ON_RATIO				Value
D3	D2	D1	D0	
0	0	0	0	1 / 16
0	0	0	1	2 / 16
0	0	1	0	3 / 16
0	0	1	1	4 / 16
0	1	0	0	5 / 16
0	1	0	1	6 / 16
0	1	1	0	7 / 16
0	1	1	1	8 / 16
1	0	0	0	9 / 16
1	0	0	1	10 / 16
1	0	1	0	11 / 16
1	0	1	1	12 / 16
1	1	0	0	13 / 16
1	1	0	1	14 / 16
1	1	1	0	15 / 16
1	1	1	1	16 / 16 (Default)

The advantage of this function is that it has 16-step to fine tune the brightness. If you would not like to decrease the brightness of the backlight, please set to “1111”.
(Please refer to the example in the following page.)

Register	R/ \bar{W}	Address	D7	D6	D5	D4	D3	D2	D1	D0
R12	0	0Ch	LED_ON_CYCLE				LED_ON_RATIO			

LED_ON_CYCLE : Set the cycle of enable signal.

Need to keep the frequency of the enable signal more than 120Hz to prevent the backlight twinkle visible.

(Please refer to the example in the following page.)

LED_ON_CYCLE				Value
D7	D6	D5	D4	
0	0	0	0	1
0	0	0	1	2
0	0	1	0	3
0	0	1	1	4
0	1	0	0	5
0	1	0	1	6
0	1	1	0	7
0	1	1	1	8 (Default)
1	0	0	0	9
1	0	0	1	10
1	0	1	0	11
1	0	1	1	12
1	1	0	0	13
1	1	0	1	14
1	1	1	0	15
1	1	1	1	16

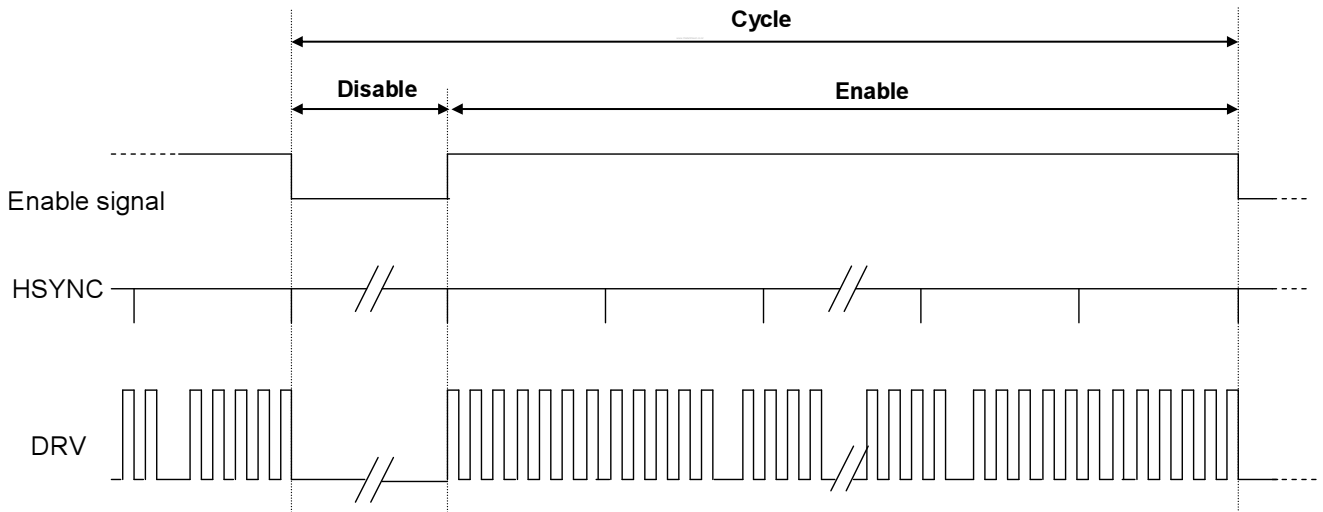

$$16 * \text{LED_ON_CYCLE} = \text{LED_ON_CYCLE} * (\text{LED_ON_RATIO} * 16) + \text{LED_ON_CYCLE} * (16 - \text{LED_ON_RATIO} * 16)$$

(Cycle)
(Enable)
(Disable)
Unit : HSYNC

for example:
 LED_ON_RATIO is "1001", and LED_ON_CYCLE is "0111", then:
 Cycle = 16 * 8 = 128(HSYNC)
 Enable = 8 * ((10/16) * 16) = 80(HSYNC)
 Disable = 8 * (16 - (10/16) * 16) = 48(HSYNC) → 62.5% on

Register	R/ \overline{W}	Address	D7	D6	D5	D4	D3	D2	D1	D0
R13	0	0Dh	X	1	X	X	GRB	1	SHDB1	DISP

DISP : Standby (power saving) mode setting

DISP	Description
0	Standby (Display OFF); timing control, DAC, and DC/DC converter are off, and register data should be kept (Default)
1	Normal operation (Display ON), with power on/off sequence

Note : In standby mode, Source Driver output =0V, VGH =0V, VGL =0V, FRP =0V

SHDB1 : Shut down for back light power converter

SHDB1	Description
0	The back light power converter is off (Default)
1	The back light power converter is controlled by STB's power on/off sequence

GRB : Register reset setting

GRB	Description
0	Reset all registers to default value
1	Normal operation (Default)

3.6.3 Suggested Serial Command Settings:

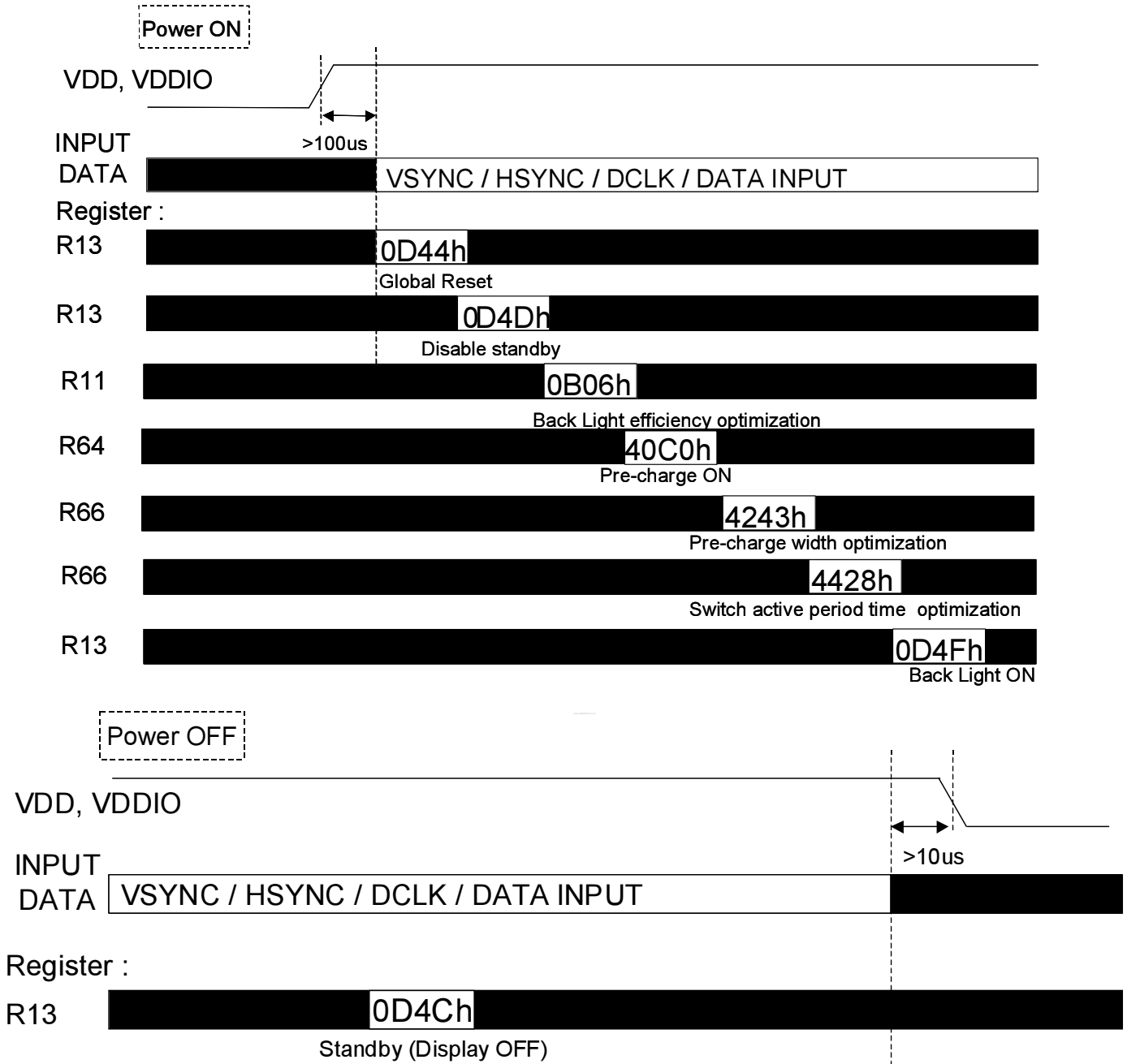

4. Optical specification

Item	Symbol	Condition	Min.	Typ.	Max.	Unit	Remark
Response Time	Rise	$\theta = 0^\circ$	-	20	40	ms	Note 4
	Fall		-	20	40	ms	
Contrast ratio	CR	At optimized viewing	250	500	-		Note 6, 7
Viewing Angle	Top	$CR \geq 10$	70	80	-	deg.	Note 8
	Bottom		70	80	-		
	Left		70	80	-		
	Right		70	80	-		
Brightness	Y_L	$\theta = 0^\circ$	200	300	-	cd/m ²	Note 9
White Chromaticity	X	$\theta = 0^\circ$	0.27	0.32	0.37		
	y	$\theta = 0^\circ$	0.31	0.36	0.41		

Note 1: Measurement is in the dark room, optical ambient temperature =25°C, and backlight current $I_L=20$ mA

Note 2: To be measured in the dark room.

Note 3: To be measured on the center area of panel with a field angle of 1° by Topcon luminance meter BM-7, after 10 minutes operation.

Note 4: Definition of response time:

The output signals of photo detector are measured when the input signals are changed from “black” to “white”(falling time) and from “white” to “black”(rising time), respectively.

Note 5. From liquid crystal characteristics, response time will become slower and the color of panel will become darker when ambient temperature is below 25°C.

Note 6. Definition of contrast ratio:

Contrast ratio is calculated with the following formula.

$$\text{Contrast ratio (CR)} = \frac{\text{Photo detector output when LCD is at "White" state}}{\text{Photo detector output when LCD is at "Black" state}}$$

Note 7. White $V_i = V_{i50} + 1.5V$

Black $V_i = V_{i50} \pm 2.0V$

“±” means that the analog input signal swings in phase with COM signal.

“+” means that the analog input signal swings out of phase with COM signal.

V_{i50} : The analog input voltage when transmission is 50%

The 100% transmission is defined as the transmission of LCD panel when all the input terminals of module are electrically opened.

Note 8. Definition of viewing angle: refer to figure as below.

Note 9. Measured at the center area of the panel when all the input terminals of LCD panel are electrically opened.

5. Absolute Ratings of Ambient Environment

No.	Test items	Conditions	Remark
1	High Temperature Storage	Ta= 80°C 240Hrs	
2	Low Temperature Storage	Ta= -25°C 240Hrs	
3	High Temperature Operation	Ta= 60°C 240Hrs	
4	Low Temperature Operation	Ta= 0°C 240Hrs	
5	High Temperature & High	Ta= 60°C . 90% RH 240Hrs	Operation
6	Heat Shock	-25°C~80°C, 50 cycle, 2Hrs/cycle	Non-operation
7	Electrostatic Discharge	±200V,200pF(0Ω), once for each	Non-operation
8	Vibration	Frequency range : 10~55Hz Stoke : 1.5mm Sweep : 10~55Hz~10Hz 2 hours for each direction of X,Y,Z (6 hours for total)	Non-operation JIS C7021, A-10 condition A
9	Mechanical Shock	100G . 6ms, ±X,±Y,±Z 3 times for each direction	Non-operation JIS C7021, A-7 condition C
10	Vibration (With Carton)	Random vibration: 0.015G ² /Hz from 5~200Hz -6dB/Octave from 200~500Hz	IEC 68-34
11	Drop (With Carton)	Height: 60cm 1 corner, 3 edges, 6 surfaces	

Note 1 : Ta: Ambient Temperature.

Note 2: In the standard condition, there is not display function NG issue occurred. All the cosmetic specification is judged before the reliability stress.

6. Packing Form

