



Doc. Version	0.2
Total Page	24
Date	2009/05/15

## Product Specification

### 4.3" COLOR TFT-LCD MODULE

**Model Name : A043FW03 V0**

---

**Planned Lifetime:** From 2009/Apr To 2010/Dec

---

**Phase-out Control:** From 2010/Jul To 2010/Dec

---

**EOL Schedule:** 2010/Dec

---

< □ >Preliminary Specification

<   >Final Specification

Note: The content of this specification is subject to change.

© 2008 AU Optronics  
All Rights Reserved,  
Do Not Copy.

## Record of Revision

Version	Revise Date	Page	Content
0.0	2009/03/03		First draft.
0.1	2009/03/09	6	Update dimensions tolerance
		8	Update pin assignment
0.2	2009/03/15	5	Add LCM weight
		6	Update label position
		10	Add Panel Power Consumption & Current Consumption
		11	Update LED Supply Max Current
		14	Update Timing Condition
		19	Update touch panel Electrical characteristics Resistance X (Film)
		22	Update RA condition

For TomTom Internal Use Only

**Contents:**

<b><u>A.</u></b>	<b><u>General Description .....</u></b>	<b><u>4</u></b>
<b><u>B.</u></b>	<b><u>Features .....</u></b>	<b><u>4</u></b>
<b><u>C.</u></b>	<b><u>Physical Specifications .....</u></b>	<b><u>5</u></b>
<b><u>D.</u></b>	<b><u>Outline Dimension (Tentative).....</u></b>	<b><u>6</u></b>
<b><u>E.</u></b>	<b><u>Electrical Specifications.....</u></b>	<b><u>7</u></b>
1.	Pin Assignment.....	7
2.	Absolute Maximum Ratings.....	9
3.	Electrical Characteristics .....	10
a.	TFT- LCD Panel .....	10
b.	Current Consumption (AGND=GND=0V) .....	10
c.	Backlight Driving Conditions .....	11
4.	Suggested Application Circuit .....	12
5.	AC Timing .....	13
a.	Power on/off sequence .....	13
b.	Timing Condition .....	14
c.	Timing Diagram .....	15
<b><u>F.</u></b>	<b><u>Optical specifications (Note 1, 2) .....</u></b>	<b><u>17</u></b>
<b><u>G.</u></b>	<b><u>Touch Screen Panel Specifications .....</u></b>	<b><u>20</u></b>
<b><u>1.</u></b>	<b><u>Electrical Characteristics .....</u></b>	<b><u>20</u></b>
2.	Mechanical Characteristics.....	20
3.	Life test Condition .....	21
4.	Attention.....	21
<b><u>H.</u></b>	<b><u>Reliability Test Items .....</u></b>	<b><u>23</u></b>
<b><u>I.</u></b>	<b><u>Packing Form.....</u></b>	<b><u>24</u></b>

## A. General Description

A043FW03 V0 is an amorphous transmissive type Thin Film Transistor Liquid crystal Display (TFT-LCD). This model is composed of a TFT-LCD, a driver, an FPC (flexible printed circuit), a backlight unit and a touch panel.

## B. Features

- 4.3-inch display with touch panel
- VA mode (Normally Black)
- Wide viewing angle
- Interfaces: parallel RGB 24-bit
- WQVGA resolution in RGB stripe dot arrangement
- DC/DC integrated
- High brightness
- Integrated touch screen panel (resistive type)
- 3-in-1 FPC for LCD signals, backlight LED power and touch panel
- Green design

For TomTom Internal Use Only

### C. Physical Specifications

NO.	Item	Unit	Specification	Remark
1	Display Resolution	dot	480 RGB (H)×272(V)	
2	Active Area	mm	95.04(H)×53.856(V)	
3	Screen Size	inch	4.3(Diagonal)	
4	Dot Pitch	mm	0.066(H)×0.198(V)	
5	Color Configuration	--	R. G. B. Stripe	Note 1
6	Color Depth	--	16.7M Colors	
7	Overall Dimension	mm	105.5(H) × 67.2(V) × 4.05(T)	Note 2
8	Weight	g	59	
9	Touch panel surface treatment	--	Hard coating (AG Haze 7%) 3H	
10	Display Mode	--	Normally Black	
11	Gray Level Inversion Direction		No GSI	

Note 1: Below figure shows dot stripe arrangement.

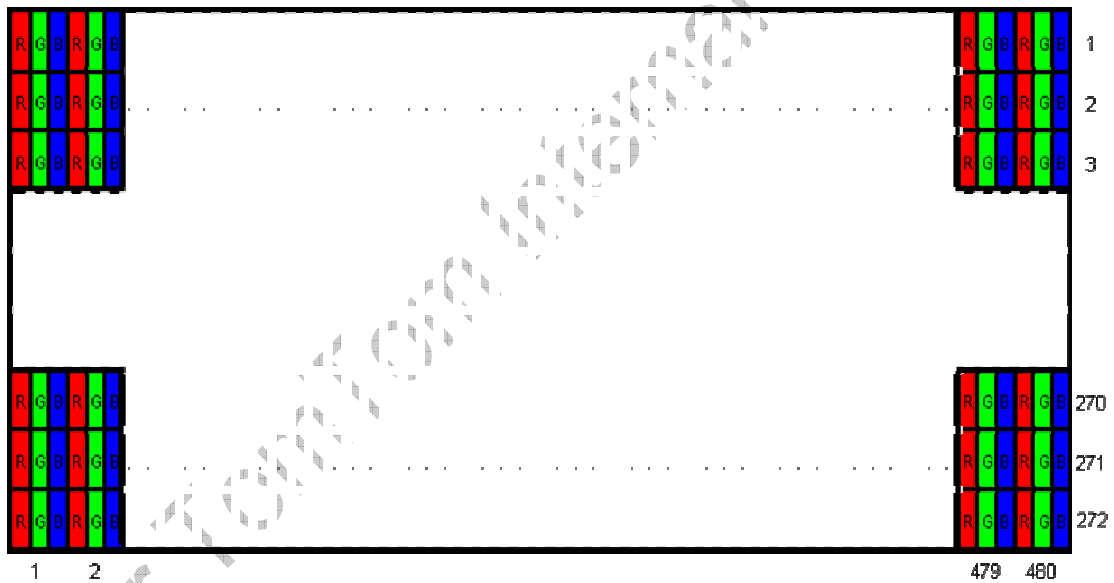

Note 2: Not including FPC. Refer to the drawing next page for further information.

## D. Outline Dimension (Tentative)

- NOTES:
1. General tolerance  $\pm 0.3\text{mm}$
  2. The bending radius of FPC should be larger than  $0.6\text{mm}$
  3. Unit : mm
  4. \* It means the casing opening should not be larger than this area .

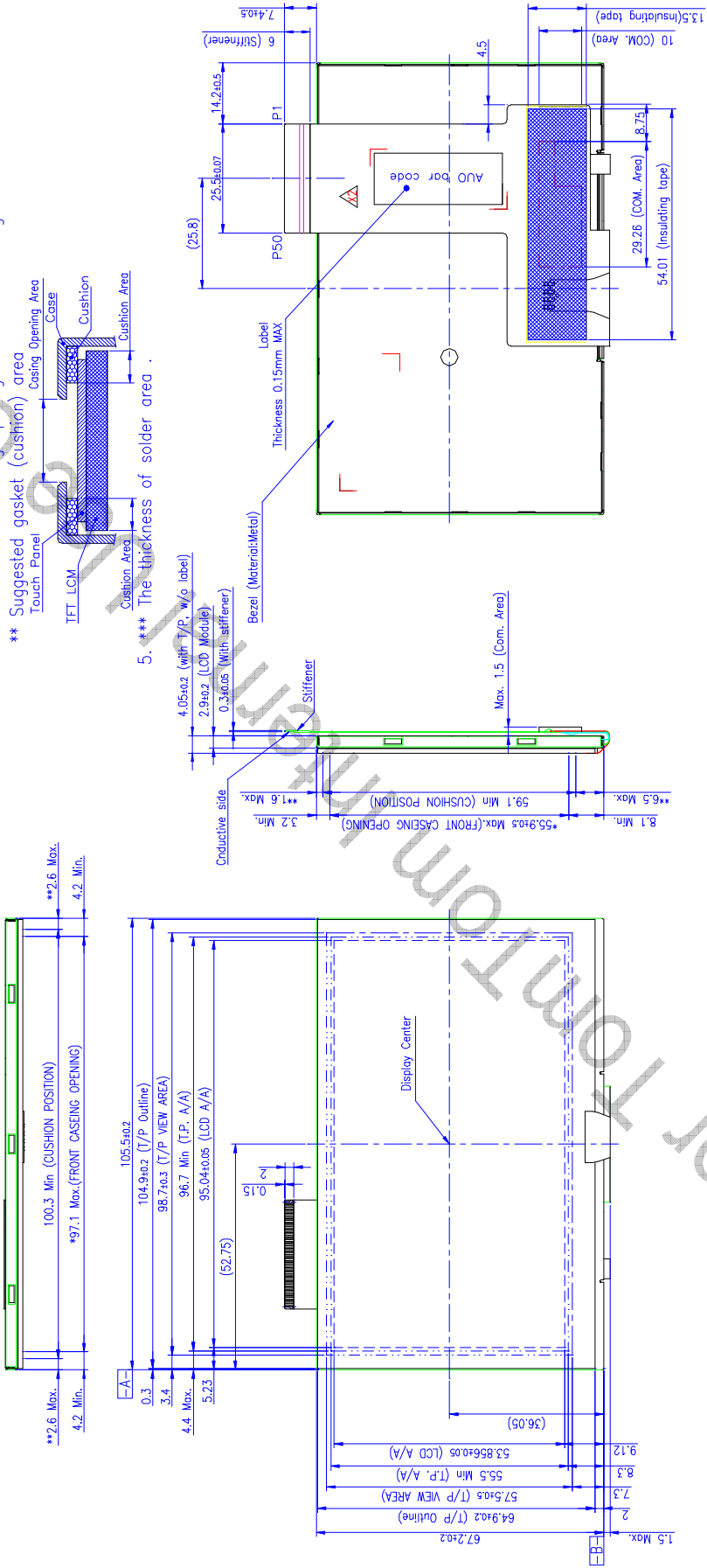

ALL RIGHTS STRICTLY RESERVED. ANY PORTION OF THIS PAPER SHALL NOT BE REPRODUCED, COPIED, OR TRANSFORMED TO ANY OTHER FORMS WITHOUT PERMISSION FROM AU OPTRONICS CORP.

## E. Electrical Specifications

### 1. Pin Assignment

Recommended connector: FH12-50S-0.5SH

No.	Pin Name	I/O	Description	Remarks
1	GND	G	GND	
2	GND	G	GND	
3	VDD	PI	Power supply for analog circuit	
4	VDDIO	PI	Power supply for digital interface	
5	R0	I	Red Data Signal (LSB)	
6	R1	I	Red Data Signal	
7	R2	I	Red Data Signal	
8	R3	I	Red Data Signal	
9	R4	I	Red Data Signal	
10	R5	I	Red Data Signal	
11	R6	I	Red Data Signal	
12	R7	I	Red Data Signal (MSB)	
13	G0	I	Green Data Signal (LSB)	
14	G1	I	Green Data Signal	
15	G2	I	Green Data Signal	
16	G3	I	Green Data Signal	
17	G4	I	Green Data Signal	
18	G5	I	Green Data Signal	
19	G6	I	Green Data Signal	
20	G7	I	Green Data Signal (MSB)	
21	B0	I	Blue Data Signal (LSB)	
22	B1	I	Blue Data Signal	
23	B2	I	Blue Data Signal	
24	B3	I	Blue Data Signal	
25	B4	I	Blue Data Signal	
26	B5	I	Blue Data Signal	
27	B6	I	Blue Data Signal	
28	B7	I	Blue Data Signal (MSB)	
29	GND	G	GND	
30	DCLK	I	Pixel clock	
31	DISP	I	Display on/off signal	
32	HSYNC	I	Horizontal synchronizing signal	

ALL RIGHTS STRICTLY RESERVED. ANY PORTION OF THIS PAPER SHALL NOT BE REPRODUCED, COPIED, OR TRANSFORMED TO ANY OTHER FORMS WITHOUT PERMISSION FROM AU OPTONICS CORP.

33	VSYNC	I	Vertical synchronizing signal	
34	DE	I	Data enable	
35	NC	-	No connect	
36	NC	-	No connect	
37	NC	-	No connect	
38	NC	-	No connect	
39	GND	G	GND	
40	GND	G	GND	
41	TP_R	I/O	X Right	
42	TP_B	I/O	Y Bottom	
43	TP_L	I/O	X Left	
44	TP_U	I/O	Y Up	
45	GND	G	GND	
46	VLED-	PI	LED backlight cathode	
47	NC	-	No connect	
48	NC	-	No connect	
49	VLED+	PI	LED backlight anode	
50	GND	G	GND	

I: Digital signal input, O: Digital signal output, G: GND, PI: Power input, C: Capacitor

For TomTom Inc.



## 2. Absolute Maximum Ratings

Items	Symbol	Values		Unit	Condition
		Min.	Max.		
Power Supply Voltage	VDD	-0.3	4.5	V	
Interface Supply Voltage	VDDIO	-0.3	4.5	V	
LED Reverse Voltage	$V_r$	2.9	3.5	V	One LED (note 2.)
LED Forward Current	$I_f$	--	25	mA	One LED
Operation Temperature	$T_{op}$	-20	70	°C	
Storage Temperature	$T_{st}$	-30	80	°C	

Note 1. If the operating condition exceeds the absolute maximum ratings, the TFT-LCD module may be damaged permanently. Also, if the module operated with the absolute maximum ratings for a long time, its reliability may drop.

Note 2. Using 29 Volt ( $2.9 \times 10 = 29$ ) as the backlight LED power source will cause low LED power supply current. Please make sure the power supply current needs to be 22mA.

Signal LED driving Voltage					
Min.	2.9	Typ.	3.2	Max.	3.5

### 3. Electrical Characteristics

The following items are measured under stable condition and suggested application circuit.

#### a. TFT- LCD Panel

Parameter	Symbol	Min	Typ	Max	Unit	Notes
Power Supply Voltage	VDD	3	3.3	3.6	V	
Interface Supply Voltage	VDDIO	1.7	3.3	VDD	V	
Input Signal Voltage	V <sub>ih</sub>	0.7* VDDIO	--	VDDIO	V	
	V <sub>il</sub>	GND	--	0.3* VDDIO	V	
Power Supply Current	I <sub>VDD</sub>		11	13	mA	
Frame Frequency	f <sub>Frame</sub>	--	60	70	Hz	
Dot Data Clock	DCLK	5	9.2	12	MHz	
Power Consumption	White	-	32	43	mW	
	Black	-	28	35	mW	

Note 1. Panel surface temperature should be kept less than content of section E.2. "Absolute maximum ratings"

Note 2. I<sub>VDD</sub> Typ is in color bar pattern. I<sub>VDD</sub> Max is in black pattern.

#### b. Current Consumption (AGND=GND=0V)

Parameter	Symbol	Condition	Min.	Typ.	Max.	Unit	Remark
Input Current for VDD	I <sub>VDD</sub>	VDD=3.3V	-	9.5	12	mA	Note 1, 2
	I <sub>VDD</sub> (STANDBY)	VDD=3.3V	-	8.5	11	uA	Note 3
Input Current for VDDIO	I <sub>VDDIO</sub>	VDDIO=3.3V	-	75	80	uA	Note 1, 2
	I <sub>VDDIO</sub> (STANDBY)	VDDIO=3.3V	-	70	75	uA	Note 3

Note 1: Test Condition is under typical Eletrical DC and AC characteristics.

Note 2: Test pattern is the following picture.



Note 3: In standby mode, all digital signals are stopped. Ex. DCLK, HSYNC ..etc.

**c. Backlight Driving Conditions**

Parameter	Symbol	Min.	Typ.	Max.	Unit	Remark
LED Supply Current	$I_L$		22	24	mA	single serial
Power Consumption	PBL		704	875	mW	
LED Life Time	$L_L$	10,000	---	---	Hr	Note 2

Note 1: LED backlight is 10 LEDs serial type. Suggestion is driven by current 22mA for each LED string.

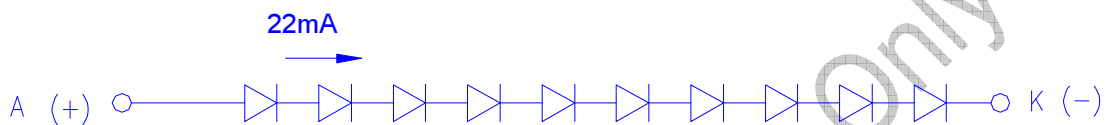

Note 2: Define "LED Lifetime": brightness is decreased to 50% of the initial value. LED Lifetime is restricted under normal condition, ambient temperature = 25°C and LED lightbar current = 20 mA.

Note 3: If it uses larger LED lightbar voltage/ current more than 20mA, it maybe decreases the LED lifetime

For TomTom Internal Use Only

## 4. Suggested Application Circuit

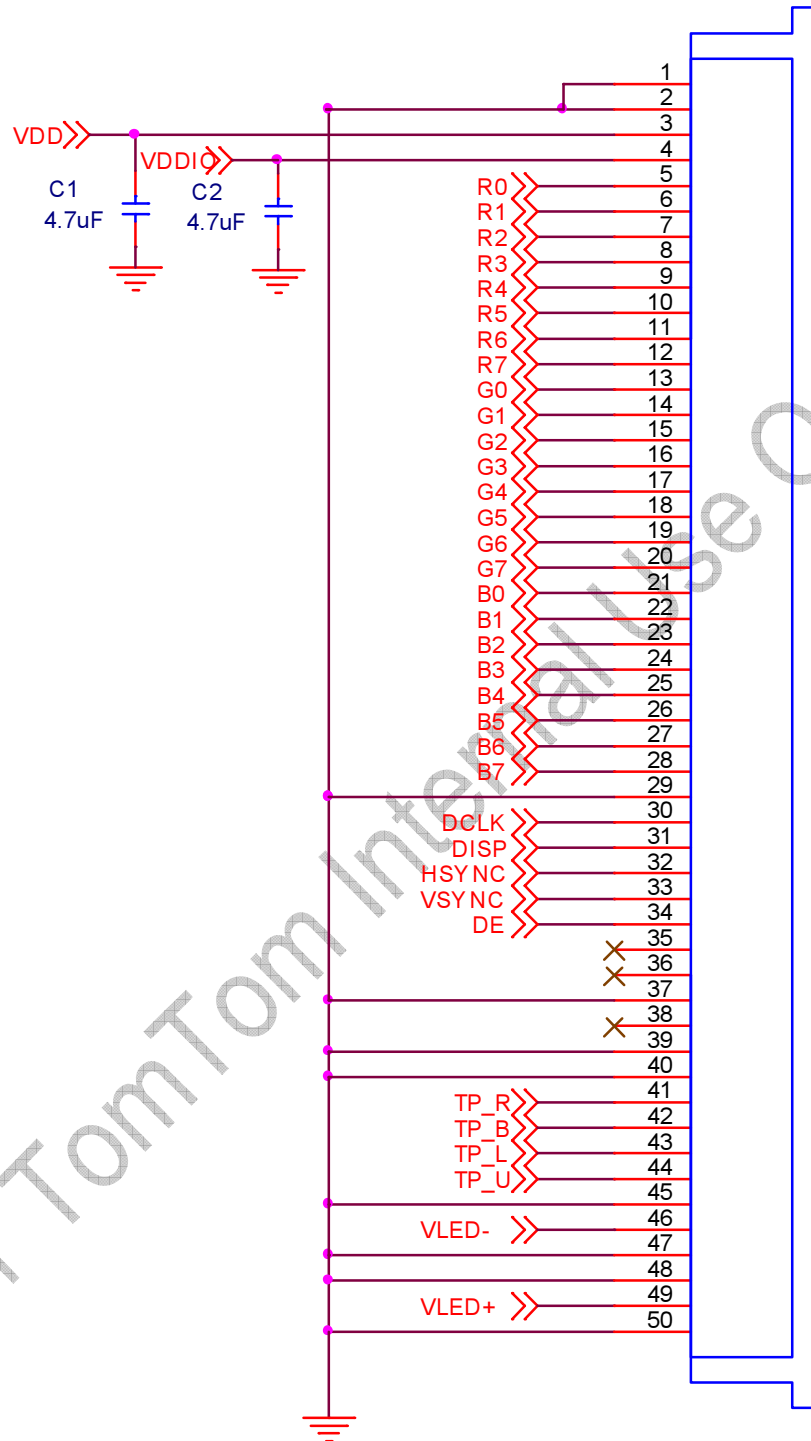

## 5. AC Timing

### a. Power on/off sequence

#### Power On (Display ON; Standby Disabling)

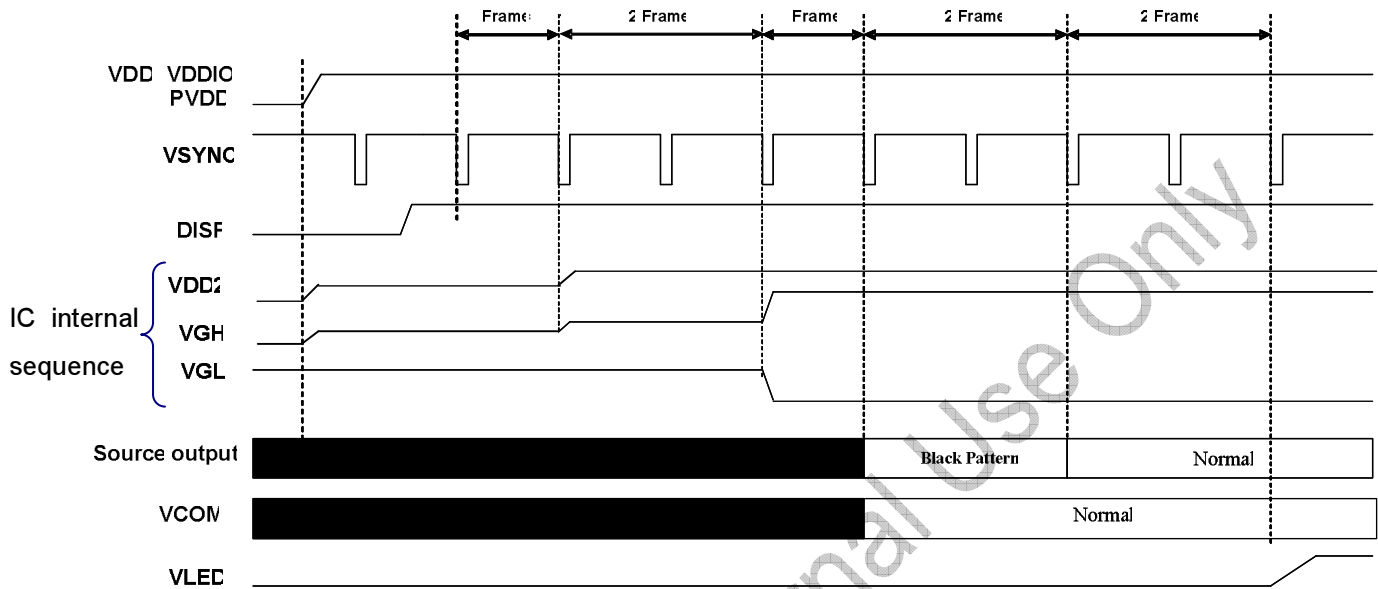

Notes: The driver IC default is on standby mode. It can be changed to normal operation by using DISP hard pin.

#### Power-Off (Display Off; Standby Enabling)

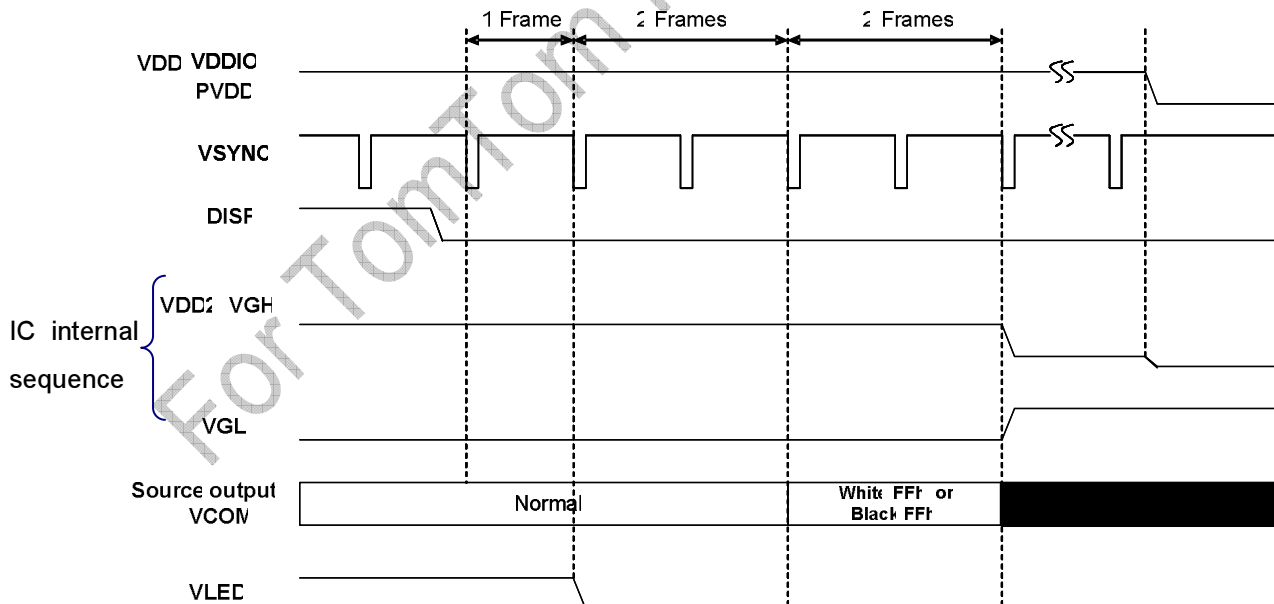

**b. Timing Condition**

Parameter		Symbol	Min.	Typ.	Max.	Unit.	Remark
DCLK	Frequency	1/Tdclk	5	9.2	12	MHz	
	CLK pulse duty	Tcwh	40	--	--	ns	
	CLK pulse duty	Tcwl	40	--	--	ns	
Data	Setup Time	Tdsu	12	--	--	ns	
	Hold Time	Tdhd	12	--	--	ns	
DE	Setup Time	Tdesu	12	--	--	ns	
	Hold Time	Tdehd	12	--	--	ns	
Frame Frequency	Cycle	tv		16.7		ms	
1 Frame Scanning Time	Cycle	tv	275	288	335	H	
	Display Period	tvdisp	272			H	
	Front porch	Tvfp	1	4	30	H	
	Pulse width	Tvw	1	10	10	H	
	Back porch	Tvbp	2	12	33	H	
1 Line Scanning Time	Cycle	Th	490	531	605	DCLK	
	Display Period	Thdisp	480			DCLK	
	Front porch	Thfp	2	8	60	DCLK	
	Pulse width	Thw	1	1	10	DCLK	
	Back porch	thbp	8	43	65	DCLK	

Note 1: Sync mode just can be used on the typical timing setting.

c. Timing Diagram

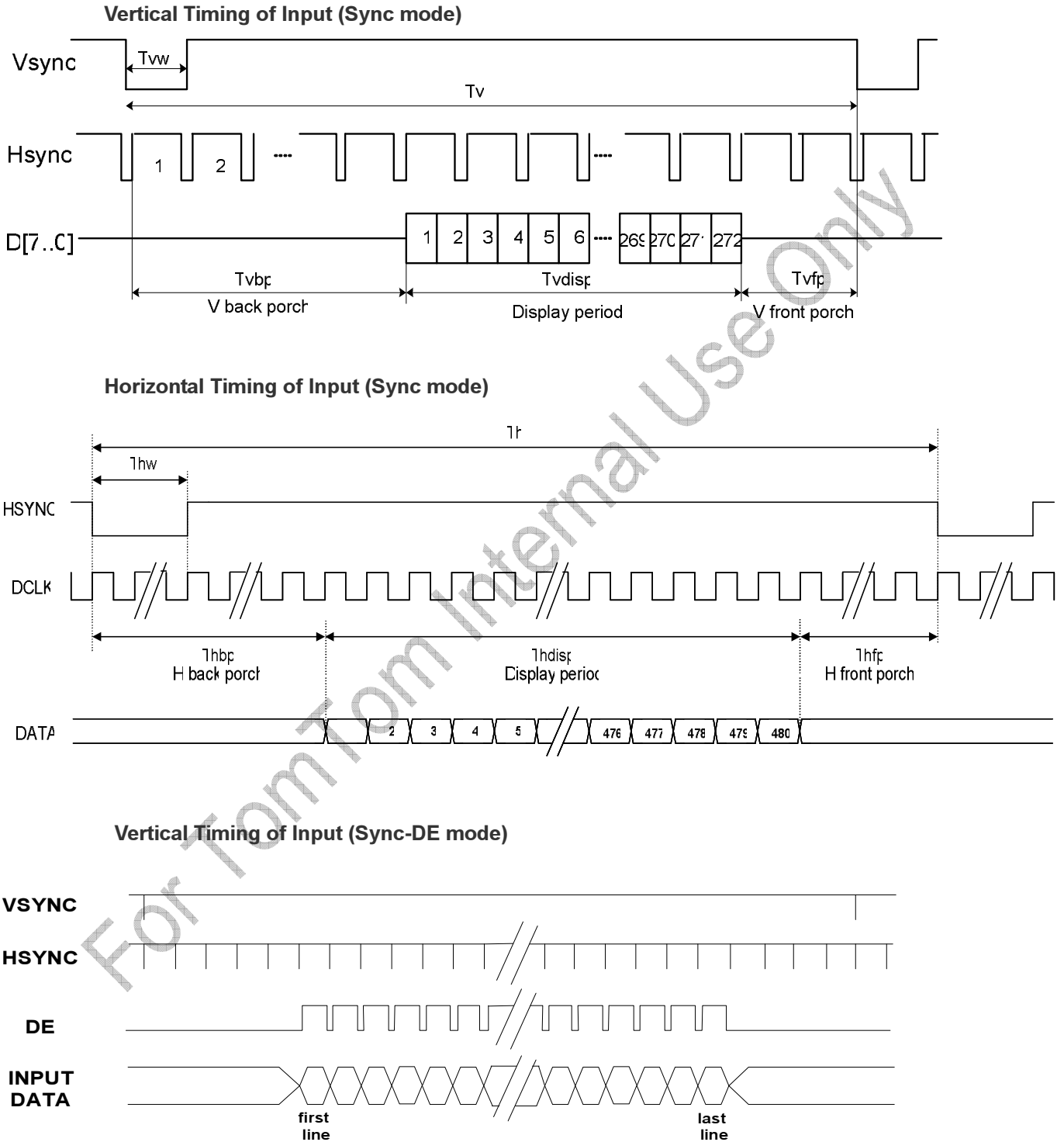





### F. Optical specifications (Note 1, 2)

Item	Symbol	Condition	Min.	Typ.	Max.	Unit	Remark
Response Time							
Rise	Tr	$\theta=0^\circ$	--	17	22	ms	Note 3
Fall	Tf		--	15	20	ms	
Contrast ratio	CR	At optimized viewing angle	400	800	--		Note 4
Viewing Angle		$CR \geq 10$				Note 5	Note 6
Top			70	80	--		
Bottom			70	80	--		
Left			70	80	--		
Right			70	80	--		
Brightness	$Y_L$	$\theta=0^\circ$	300	400	--	cd/m <sup>2</sup>	Note 6
Chromaticity	White	x	$\theta=0^\circ$	0.27	0.320	0.37	
		y	$\theta=0^\circ$	0.29	0.340	0.39	
	Red	x	$\theta=0^\circ$	0.55	0.600	0.65	
		y	$\theta=0^\circ$	0.31	0.360	0.41	
	Green	x	$\theta=0^\circ$	0.32	0.370	0.42	
		y	$\theta=0^\circ$	0.52	0.570	0.62	
	Blue	x	$\theta=0^\circ$	0.10	0.150	0.20	
		y	$\theta=0^\circ$	0.07	0.120	0.17	
Uniformity	$\Delta Y_L$	%	70	80	--	%	Note 7

Note 1: Measurement should be performed in the dark room, optical ambient temperature =25°C, and backlight current  $I_L=22$  mA

Note 2: To be measured on the center area of panel with a field angle of 1° by Topcon luminance meter BM-5A, after 10 minutes operation.

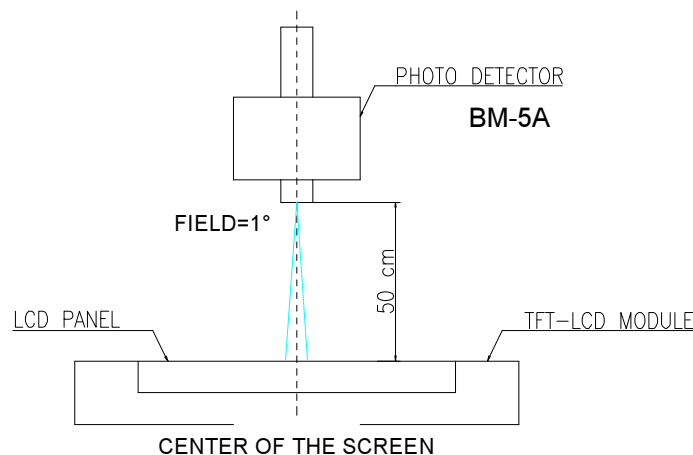

Note 3: Definition of response time:

The output signals of photo detector are measured when the input signals are changed from "black" to "white" (falling time) and from "white" to "black" (rising time), respectively.

The response time is defined as the time interval between the 10% and 90% of amplitudes. Refer to figure as below.

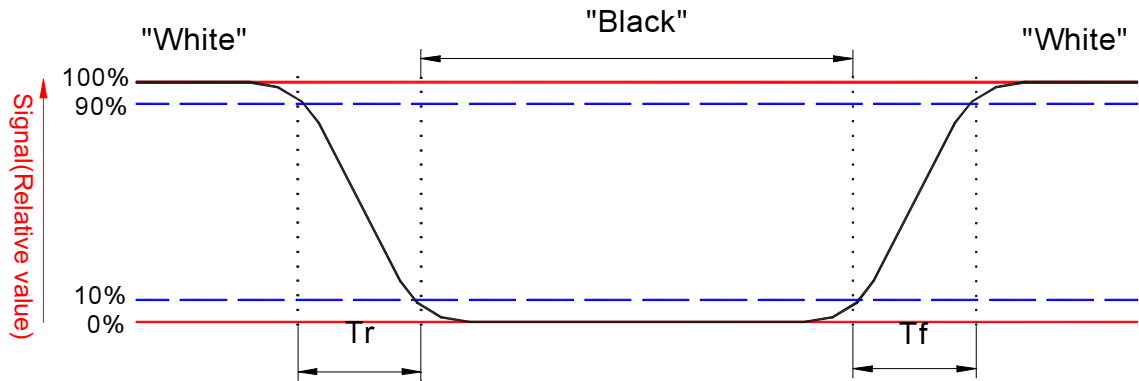

Note 4. Definition of contrast ratio:

Contrast ratio is calculated with the following formula.

$$\text{Contrast ratio (CR)} = \frac{\text{Photo detector output when LCD is at "White" status}}{\text{Photo detector output when LCD is at "Black" status}}$$

Note 5. Definition of viewing angle,  $\theta$ , Refer to figure as below.

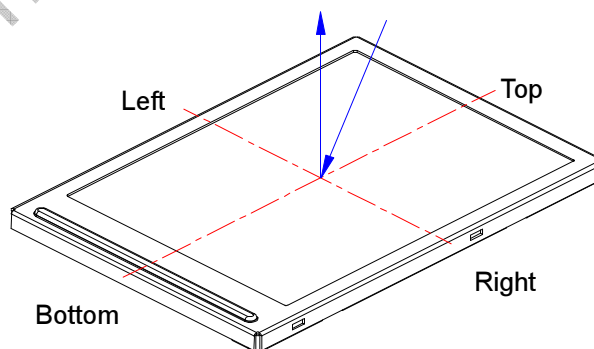

Note 6: Measured at the center area of the panel when all the input terminals of LCD panel are electrically opened.

Note 7: Luminance Uniformity of these 9 points is defined as below:

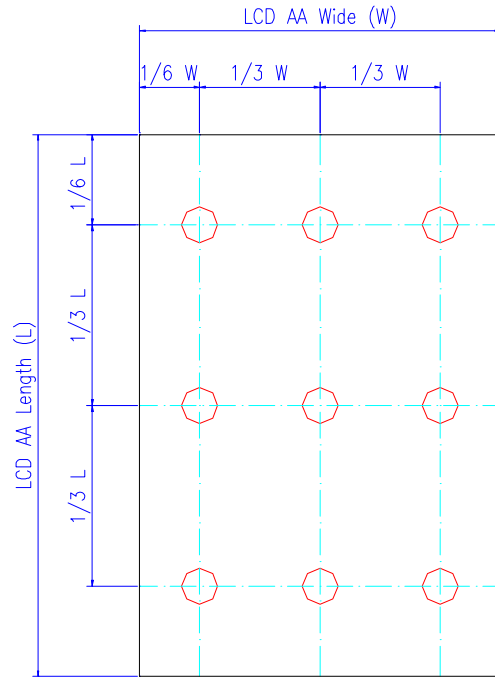

$$\text{Uniformity} = \frac{\text{minimum luminance in 9 points (1-9)}}{\text{maximum luminance in 9 points (1-9)}}$$

For TomTom International Use Only

## G. Touch Screen Panel Specifications

### 1. Electrical Characteristics

Item	Min.	Max.	Unit	Remark	
Rate DC Voltage	--	7	V		
Resistance	X (Film)	100	900	Ω	At connector
	Y (Glass)	100	900		
Linearity	-1.5%	1.5%	--	Note 1, test by 250 gf	
Chattering	--	--	ms	At connector pin	
Insulation Resistance	20	--	MΩ	DC 25V	

Note 1: Measurement condition of Linearity: difference between actual voltage & theoretical voltage is an error at any points. Linearity is the value max. error voltage divided by voltage difference on within T/P active area inside 2mm.

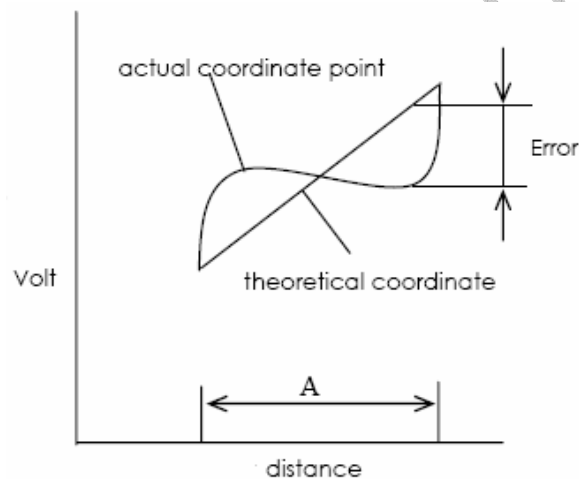

### 2. Mechanical Characteristics

Item	Min.	Max.	Unit	Remark
Hardness of Surface	3	--	H	JIS K-5400
Operation Force (Pen or Finger)	--	80	g	Note 1

Note 1: Within "active area inside 2mm", but not on the edge and dot-spacer.

Note 2: Operation force measurement is under test condition as figure below.

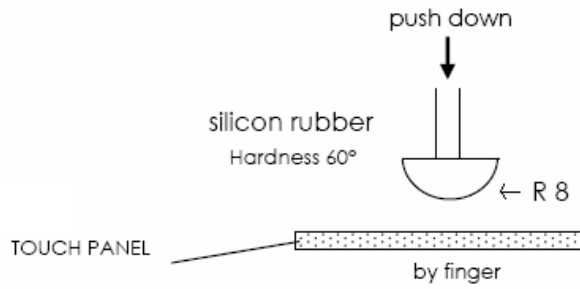

### 3. Life test Condition

Item	Min.	Max.	Unit	Remark
Notes Life	$10^5$	=	times	Note 1, 2
Input Life	$10^6$	=	times	Note 1, 3

Note 1: Life test condition (by pen): From active area edge toward the center at 3 mm distance, slide on active area and use R 0.8mm polyacetal pen, input force : 250gf, frequency : 60mm/sec. Sliding from A to B complete 1 time. shown as figure.

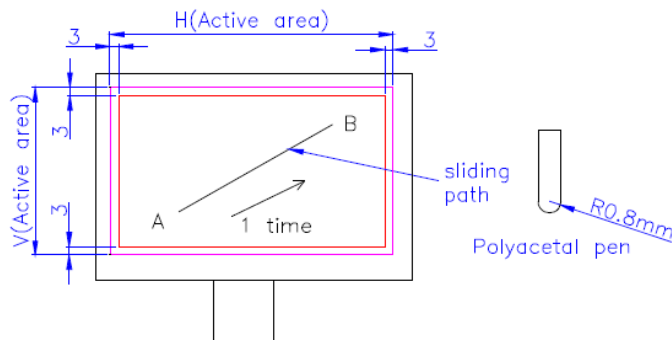

Note 2: Input Life test condition (by finger): test position on active area center and use R8.0mm silicon rubber (hardness 60°), test force: 250gf, frequency : 2times/sec. shown as figure.

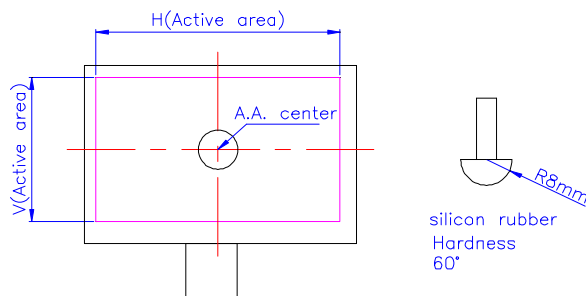

### 4. Attention

Please pay attention for below matters at mounting design of touch panel of LCD module.

1. Do not design enclosure pressing the view area to prevent from miss input.

2. Enclosure support must not touch with view area.
3. Use elastic or non-conductive material to enclosure touch panel.
4. Do not bond film of touch panel with enclosure.
5. The touch panel edge is conductive. Do not touch it with any conductive part after mounting.

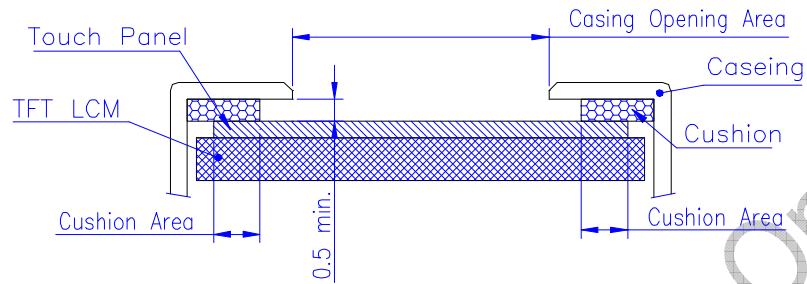

6. If user wants to clean touch panel by air gun, pressure 2kg/cm<sup>2</sup> below is suggested. Not to blow glass from FPC site to prevent FPC peeled off.
7. Do not put a heavy shock or stress on touch panel and film surface. Ex. Don't lift the panel by film face with vacuum.
8. Do not lift LCD module by FPC.
9. Please use dry cloth or soft cloth with neutral detergent (after wring dry) or one with ethanol at cleaning. Do not use any organic solvent, acid or alkali liquor.
10. Do not pile touch panel. Do not put heavy goods on touch panel.

## H. Reliability Test Items

No.	Test items	Conditions		Remark
1	High Temperature Storage	Ta= 85°C	160Hrs	
2	Low Temperature Storage	Ta= -40°C	160Hrs	
3	High Temperature Operation	Ta= 70°C	160Hrs	
4	Low Temperature Operation	Ta= -20°C	160Hrs	
5	High Temperature & High Humidity	Ta= 60°C. 90% RH	160Hrs	Operation
6	Heat Shock	-25°C ~70°C, 50 cycle, 2Hrs/cycle		Non-operation
7	Vibration (With Carton)	Random vibration: 0.015G <sup>2</sup> /Hz from 5~200Hz -6dB/Octave from 200~500Hz		IEC 68-34
8	Drop (With Carton)	Height: 60cm 1 corner, 3 edges, 6 surfaces		

Note 1: Ta: Ambient temperature.

Note 2: In the standard condition, there is not display function NG issue occurred. All the cosmetic specification is judged before the reliability stress.

For TomTom Internal Use Only

## I. Packing Form

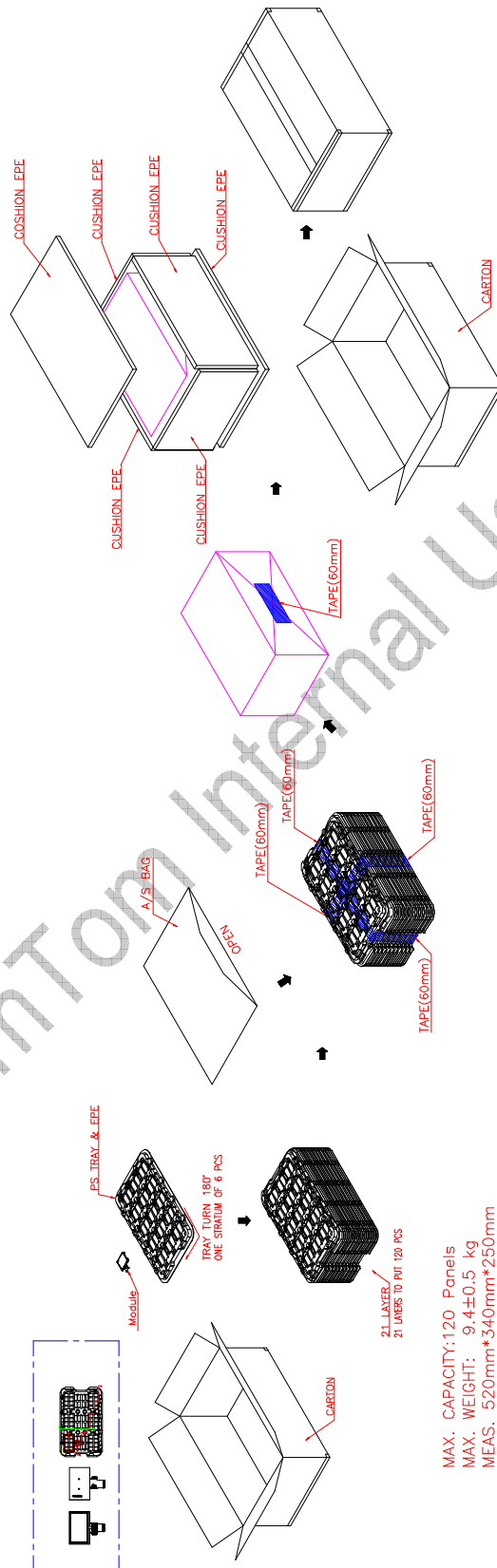

MAX. CAPACITY: 120 Panels  
 MAX. WEIGHT: 9.4±0.5 kg  
 MEAS. 520mm\*340mm\*250mm