



CUSTOMER APPROVAL SHEET

Company Name	
MODEL	A047FW01 V0
CUSTOMER APPROVED	Title : Name :

- APPROVAL FOR SPECIFICATIONS ONLY (Spec. Ver. 0.2)
- APPROVAL FOR SPECIFICATIONS AND ES SAMPLE (Spec. Ver. 0.2)
- APPROVAL FOR SPECIFICATIONS AND CS SAMPLE (Spec. Ver. 0.2)
- CUSTOMER REMARK :

AUO PM :

P/N : 97.04A19.000

Comment :



Doc. version :	0.2
Total pages :	25

Date : 2009/03/30

Product Specification

4.7" COLOR TFT-LCD MODULE/PANEL

MODEL NAME: A047FW01 V0

< > Preliminary Specification
< > Final Specification

Note: The content of this specification is subject to change.

© 2009 AU Optronics
All Rights Reserved,
Do Not Copy.

Record of Revision

Version	Revise Date	Page	Content
0.0			First Draft
0.1	2009/03/11	6	Update drawing (change label outline)
		8	Update Current Consumption
		13	Update Power On/Off Characteristics
		14	Update Optical Specification (Brightness spec & add RGB Chromaticity)
		24	Update Panel Label Information
0.2	2009/03/30	13	Update Power Off Characteristics

Contents

A. General Information	3
B. Outline Dimension	4
C. Electrical Specifications	5
1. TFT LCD Panel Pin Assignment	5
2. Absolute Maximum Ratings	7
3. Electrical DC Characteristics	8
4. Electrical AC Characteristics	10
5. Power On/Off Characteristics	13
D. Optical Specification	14
E. Touch Screen Panel Specifications	17
1. FPC Pin Assignment	17
2. Electrical Characteristics	17
3. Mechanical Characteristics	18
4. Life Test Condition	18
5. Attention	19
F. Reliability Test Items	20
G. Packing and Marking	23
1. Packing Form	23
2. Module/Panel Label Information	24
3. Carton Label Information	24
H. Precautions	25

A. General Information

This product is for PND application.

NO.	Item	Unit	Specification	Remark
1	Screen Size	inch	4.7(Diagonal)	
2	Display Resolution	dot	480RGB(H)×272(V)	
3	Overall Dimension	mm	114.24(H) × 72.88(V) × 4.2(T)	Note 1
4	Active Area	mm	103.68(H)×58.752(V)	
5	Pixel Pitch	mm	0.216(H)×0.216(V)	
6	Color Configuration	--	R. G. B. Stripe	Note 2
7	Color Depth	--	16.7M Colors	
8	NTSC Ratio	%	50	
9	Display Mode	--	Normally White	
10	Touch panel surface treatment	--	Hard coating (AG Haze 8%) 3H	
11	Weight	g	69.5	
12	Viewing direction		6 o'clock (gray inversion)	

Note 1: Not include backlight cable and FPC. Refer next page to get further information.

Note 2: Below figure shows dot stripe arrangement.

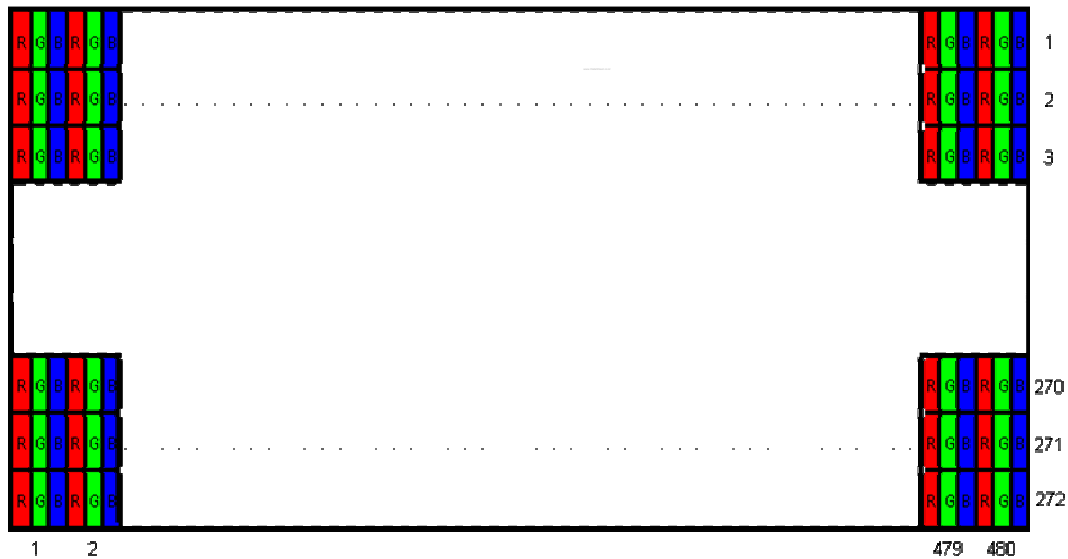

Note 3: Please refer to Electrical Characteristics chapter.

B. Outline Dimension

NOTES:

1. General tolerance $\pm 0.3\text{mm}$
2. The bending radius of FPC should be larger than 0.6mm
3. Unit : mm
4. * It means the case open should not be larger than this area .
- ** Suggested gasket (cushion) area
- *** The thickness of solder area .
6. FPC golden finger design need fully compatible with Hirose FH23-45S-0.3SHW requirement.

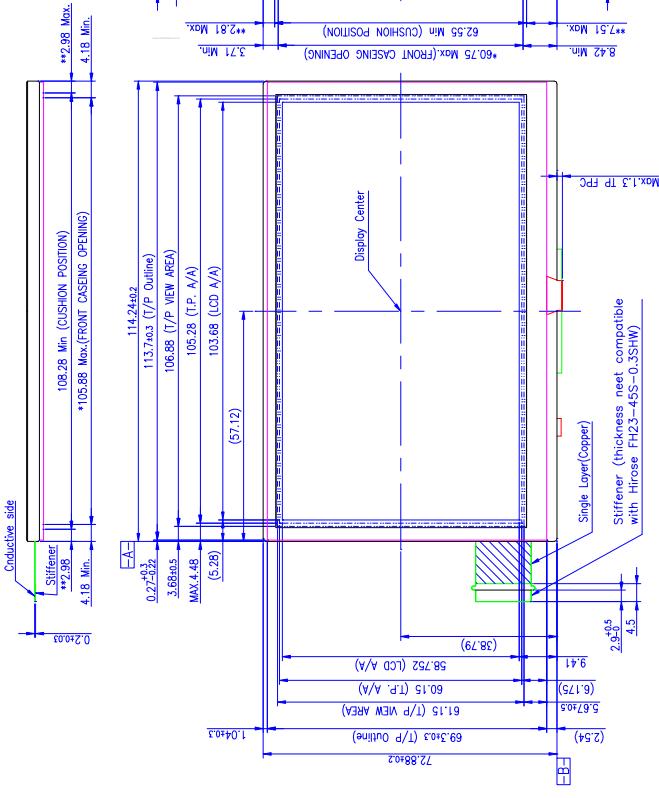
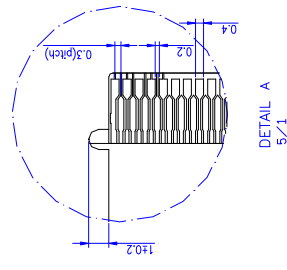
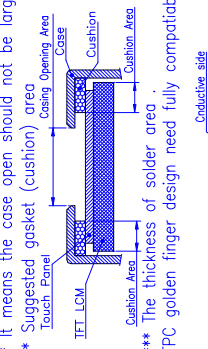

C. Electrical Specifications

1. TFT LCD Panel Pin Assignment

Recommended connector : FH23-45S-0.3SHW

Pin no	Symbol	I/O	Description	Remark
1	GND	G	GND	
2	GND	G	GND	
3	VDD	PI	Power supply : 2.5V or 3.3V	
4	VDD	PI	Power supply : 2.5V or 3.3V	
5	R0	I	Red Data Signal (LSB)	
6	R1	I	Red Data Signal	
7	R2	I	Red Data Signal	
8	R3	I	Red Data Signal	
9	R4	I	Red Data Signal	
10	R5	I	Red Data Signal	
11	R6	I	Red Data Signal	
12	R7	I	Red Data Signal (MSB)	
13	G0	I	Green Data Signal (LSB)	
14	G1	I	Green Data Signal	
15	G2	I	Green Data Signal	
16	G3	I	Green Data Signal	
17	G4	I	Green Data Signal	
18	G5	I	Green Data Signal	
19	G6	I	Green Data Signal	
20	G7	I	Green Data Signal (MSB)	
21	B0	I	Blue Data Signal (LSB)	
22	B1	I	Blue Data Signal	
23	B2	I	Blue Data Signal	
24	B3	I	Blue Data Signal	
25	B4	I	Blue Data Signal	
26	B5	I	Blue Data Signal	
27	B6	I	Blue Data Signal	
28	B7	I	Blue Data Signal (MSB)	
29	GND	G	GND	
30	DCLK	I	Pixel clock	
31	DISP	I	Display on/off signal	
32	HSYNC	I	Horizontal synchronizing signal	
33	VSYNC	I	Vertical synchronizing signal	
34	DE	I	Data enable	

35	PWR_SEL	G	VDD Power select; Low : 2.5V, High : 3.3V	
36	GND	G	GND	
37	Y2	I/O	Touch panel top electrode	
38	X2	I/O	Touch panel left electrode	
39	Y1	I/O	Touch panel bottom electrode	
40	X1	I/O	Touch panel right electrode	
41	GND	G	GND	
42	VLED1-	PI	LED1 backlight cathode	
43	VLED1+	PI	LED1 backlight anode	
44	VLED2-	PI	LED2 backlight cathode	
45	VLED2+	PI	LED2 backlight anode	

I: Input pin; P: Power pin; G: Ground pin; C: capacitor pin

2. Absolute Maximum Ratings

Items	Symbol	Values		Unit	Condition
		Min.	Max.		
Power Supply Voltage	VDD	-0.3	4.5	V	
Interface Supply Voltage	VDDIO	-0.3	4.5	V	
LED Reverse Voltage	V_r	3.2	3.5	V	One LED
LED Forward Current	I_f	--	25	mA	One LED
Operation Temperature	T_{op}	-20	70	°C	
Storage Temperature	T_{st}	-40	80	°C	

Note 1. If the operating condition exceeds the absolute maximum ratings, the TFT-LCD module may be damaged permanently. Also, if the module operated with the absolute maximum ratings for a long time, its reliability may drop

3. Electrical DC Characteristics

a. Typical Operation Condition (AGND =GND = 0V)

Item		Symbol	Min.	Typ.	Max.	Unit	Remark
Power Voltage		VDDIO	1.65	1.8	VDD	V	Digital Power Supply
		VDD	3.0	3.3	3.6	V	Analog Power Supply
Input Signal Voltage	H Level	V _{IH}	0.7xVDDIO	--	VDDIO	V	
	L Level	V _{IL}	GND	--	0.3xVDDIO	V	

b. Current Consumption (AGND=GND=0V)

Parameter	Symbol	Condition	Min.	Typ.	Max.	Unit	Remark
Input Current for VDD	I _{VDD}	VDD=3.3V	-	11	12	mA	Note 1, 2
	I _{VDD} (STANDBY)	VDD=3.3V	-	10	11	uA	Note 3
Input Current for VDDIO	I _{VDDIO}	VDDIO=3.3V	-	44	45	uA	Note 1, 2
	I _{VDDIO} (STANDBY)	VDDIO=3.3V	-	41	42	uA	Note 3

Note 1: Test Condition is under typical Electrical DC and AC characteristics.

Note 2: Test pattern is the following picture.



Note 3: In standby mode, all digital signals are stopped. Ex. DCLK, HSYNC ..etc.

c. Backlight Driving Conditions

The backlight (LED module, Note 1) is suggested to drive by constant current with typical value.

Parameter	Symbol	Min.	Typ.	Max.	Unit	Remark
LED Current	I _L		20	22	mA	Note 1
Power Consumption	P _L		704	847	mW	
LED Life Time	L _L	10,000	---	---	Hr	Note 2, 3

Note 1: LED backlight is two parallel strings and one LED for each string is as below figure. Suggest to drive by 20mA for each LED string.

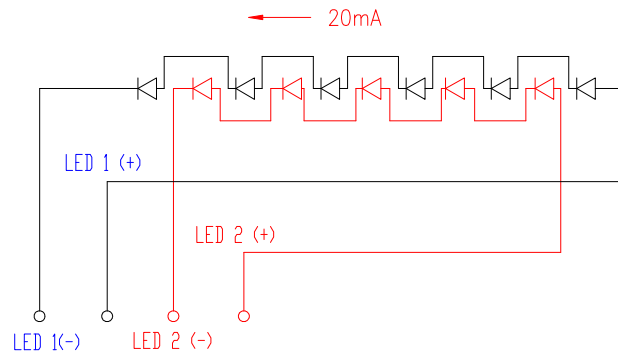

Note 2: Define "LED Lifetime": brightness is decreased to 50% of the initial value. LED Lifetime is restricted under normal condition, ambient temperature = 25°C and LED lightbar current = 35mA.

Note 3: If it uses larger LED lightbar voltage/ current more than 25mA, it maybe decreases the LED lifetime.

4. Electrical AC Characteristics

a. Signal AC Characteristics

Parameter	Symbol	Min.	Typ.	Max.	Unit	Remark
DCLK duty cycle	--	40	50	60	%	$t_{cw} / t_{DCLK} \times 100\%$
CLK pulse duty	T_{cwh}	40	--	--	ns	
CLK pulse duty	T_{cwl}	40	--	--	ns	
Data Setup Time	T_{dsu}	12	--	--	ns	
Data Hold Time	T_{dhd}	12	--	--	ns	
DE Setup Time	T_{desu}	12	--	--	ns	
DE Hold Time	T_{dehd}	12	--	--	ns	
Vsync Setup Time	T_{vst}	12	--	--	ns	
Vsync Hold Time	T_{vhd}	12	--	--	ns	
Hsync Setup Time	T_{hst}	12	--	--	ns	
Hsync Hold Time	T_{hhd}	12	--	--	ns	

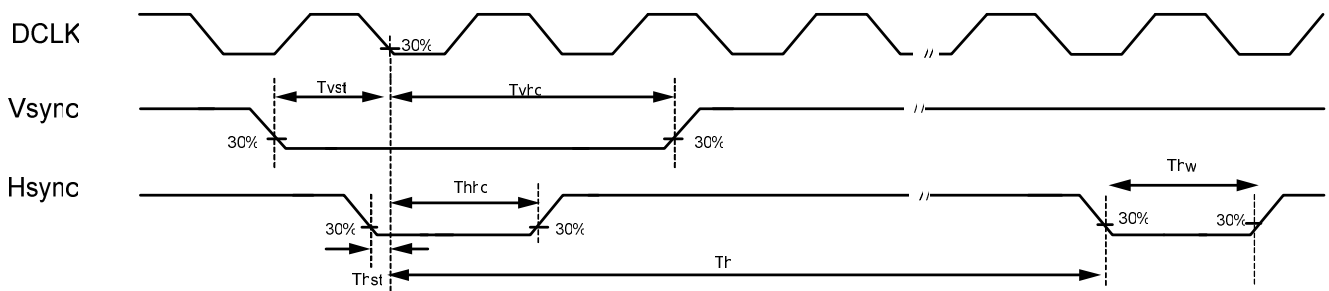
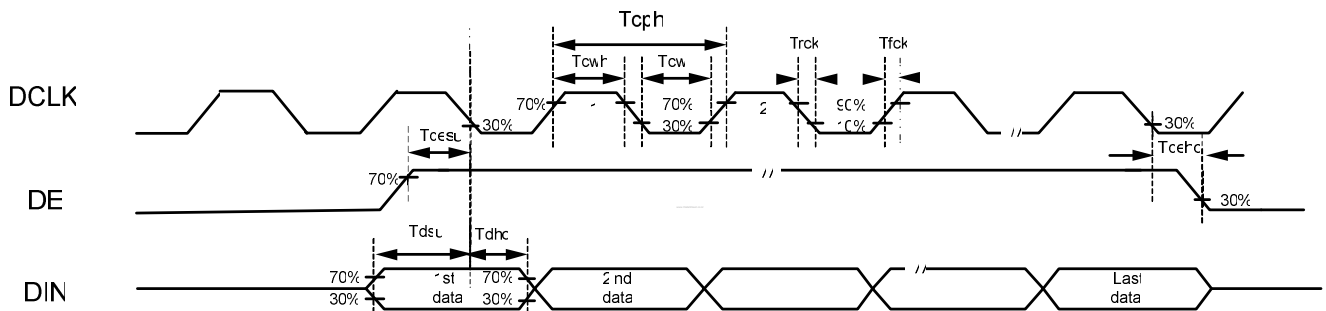

b. Input Timing

Parameter		Symbol	Min.	Typ.	Max.	Unit.	Remark
DCLK	Frequency	1/Tdclk	5	9.2	12	MHz	
Frame Frequency	Cycle	tv		16.7		ms	
1 Frame Scanning Time	Cycle	tv	275	288	335	H	
	Display Period	tvdisp	272			H	
	Front porch	Tvfp	1	4	--	H	
	Pulse width	Tvw	1	10	--	H	
	Back porch	Tvbp	2	12	--	H	
1 Line Scanning Time	Cycle	Th	490	531	605	DCLK	
	Display Period	Thdisp	480			DCLK	
	Front porch	Thfp	2	8	--	DCLK	
	Pulse width	Thw	1	1	--	DCLK	
	Back porch	thbp	8	43	--	DCLK	

Note 1: Sync mode just can be used on the typical timing setting.

c. Timing Diagram

Vertical Timing of Input(Sync-DE mode)

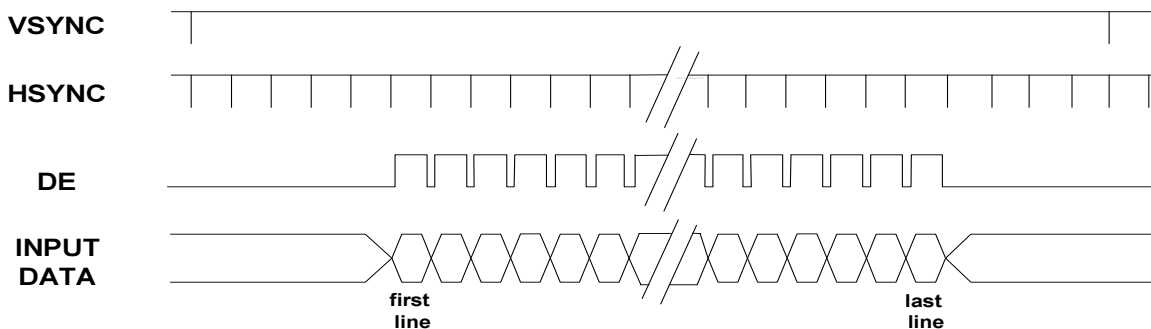

Vertical Timing of Input(Sync mode)

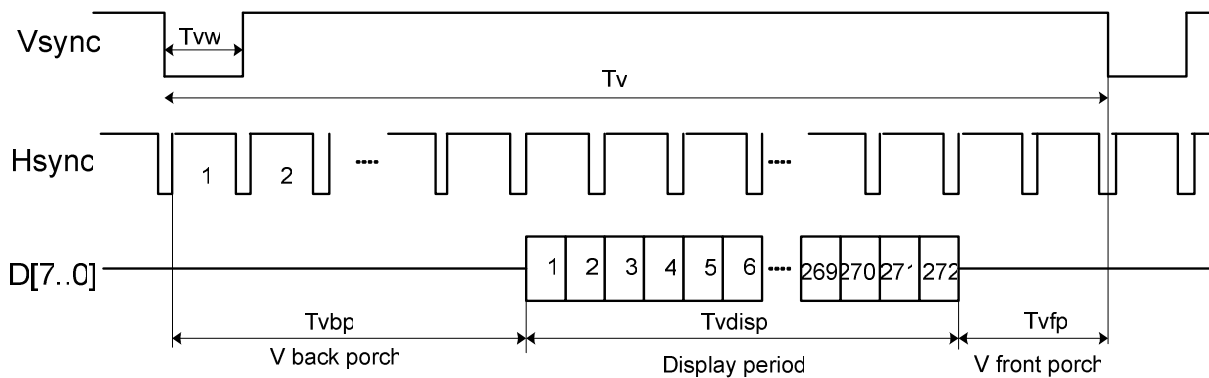

Horizontal Timing of Input(Sync mode)

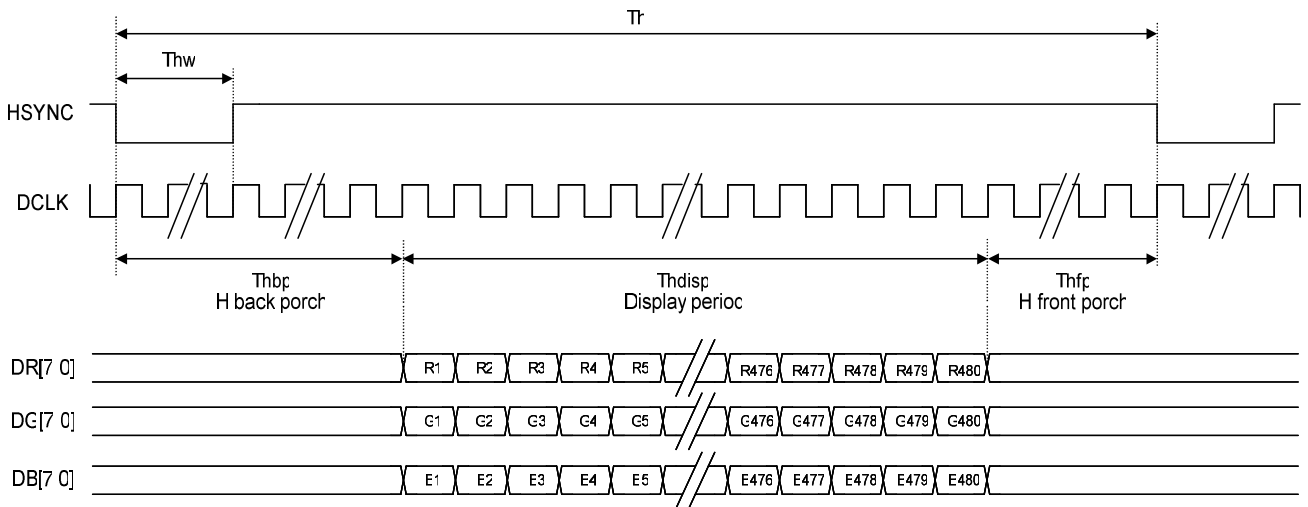

Horizontal Timing of Input (Sync-DE mode)

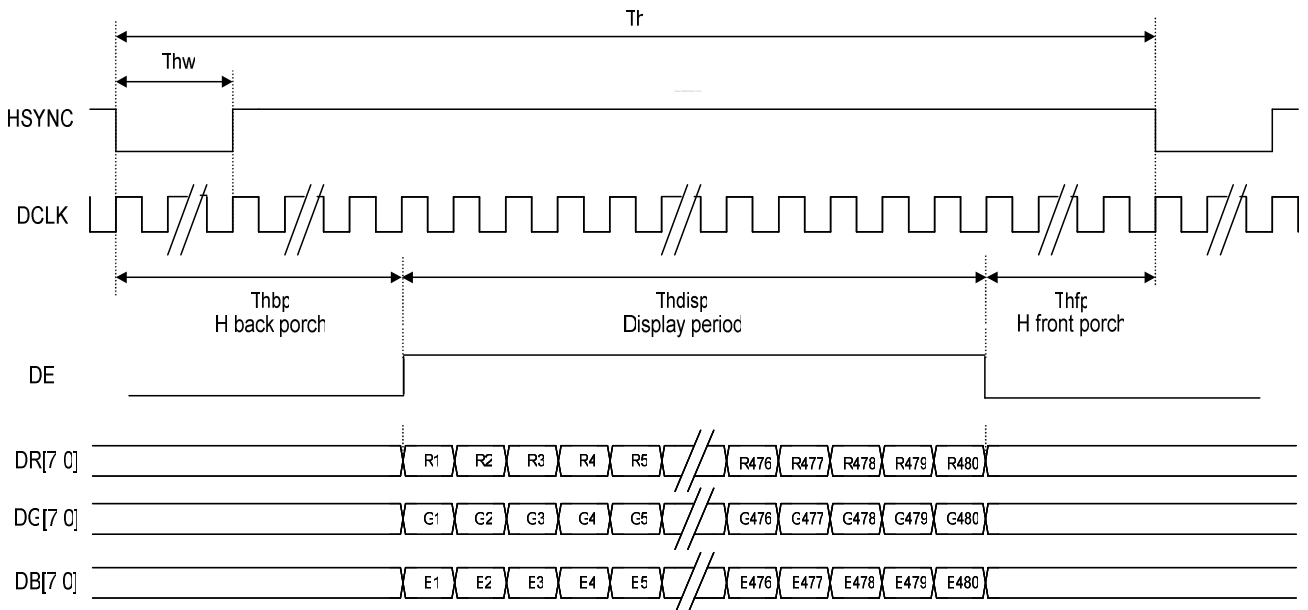

5. Power On/Off Characteristics

a. Recommended Power On Sequence

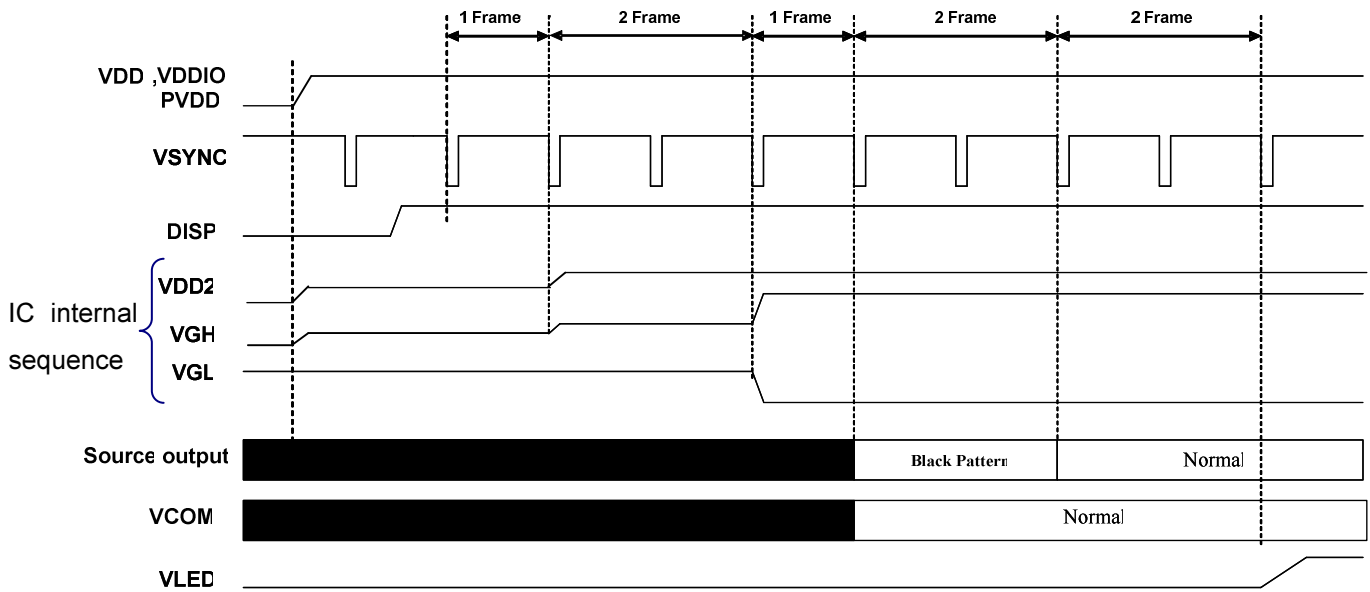

Notes: The driver IC default is on standby mode. It can be changed to normal operation by using DISP hard pin.

b. Recommended Power Off Sequence

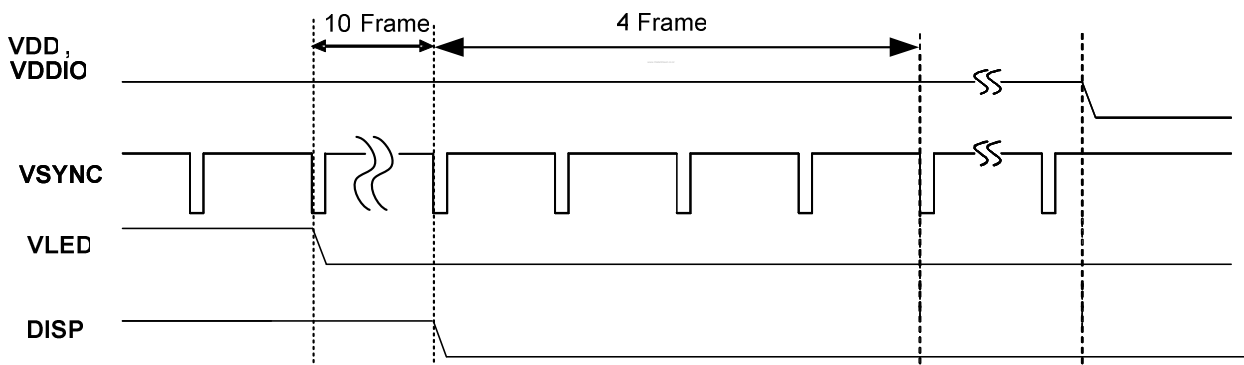

D. Optical Specification

All optical specification is measured under typical condition (Note 1, 2)

Item	Symbol	Condition	Min.	Typ.	Max.	Unit	Remark
Response Time							
Rise	Tr	$\theta=0^\circ$	--	15		ms	Note 3
Fall	Tf		--	20		ms	
Contrast ratio	CR	At optimized viewing angle	300	400	--		Note 4
Viewing Angle	Top	CR \square 10		50	--	deg.	Note 5
	Bottom			55	--		
	Left			65	--		
	Right			65	--		
Brightness	Y_L	$\theta=0^\circ$	320	380	--	cd/m ²	Note 6
Chromaticity	White	X	$\theta=0^\circ$	0.26	0.31	0.36	
		Y	$\theta=0^\circ$	0.28	0.33	0.38	
	Red	X	$\theta=0^\circ$	0.53	0.58	0.63	
		Y	$\theta=0^\circ$	0.29	0.34	0.39	
	Green	X	$\theta=0^\circ$	0.29	0.34	0.39	
		Y	$\theta=0^\circ$	0.53	0.58	0.63	
	Blue	X	$\theta=0^\circ$	0.1	0.15	0.2	
		Y	$\theta=0^\circ$	0.04	0.09	0.14	
Uniformity	ΔY_L	%	75	80	--	%	Note 7

Note 1: Ambient temperature =25°C, and LED lightbar voltage $V_L = 12 V$. To be measured in the dark room.

Note 2: To be measured on the center area of panel with a viewing cone of 1° by Topcon luminance meter BM-5A, after 15 minutes operation.

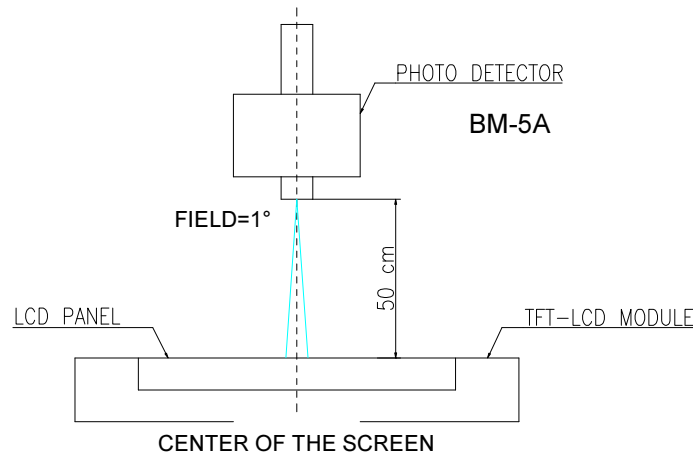

Note 3: Definition of response time:

The output signals of photo detector are measured when the input signals are changed from "black" to "white"(falling time) and from "white" to "black"(rising time), respectively.

The response time is defined as the time interval between the 10% and 90% of amplitudes. Refer to figure as below.

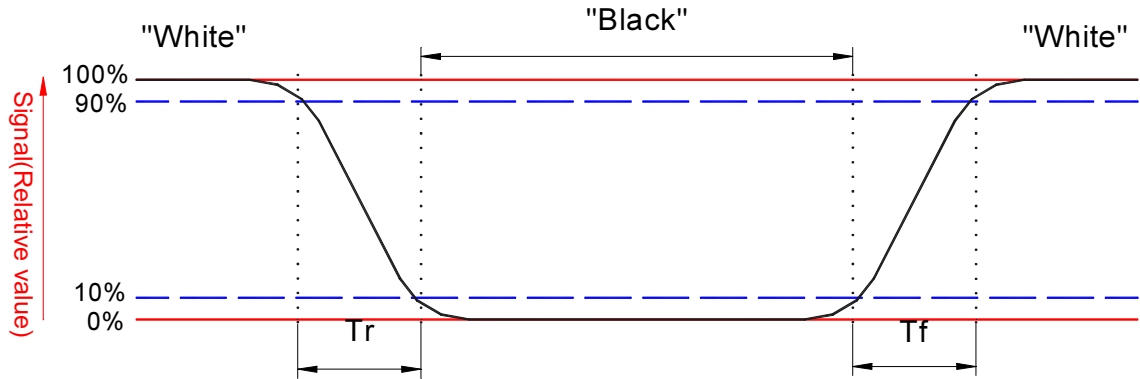

Note 4. Definition of contrast ratio:

Contrast ratio is calculated with the following formula.

$$\text{Contrast ratio (CR)} = \frac{\text{Photo detector output when LCD is at "White" status}}{\text{Photo detector output when LCD is at "Black" status}}$$

Note 5. Definition of viewing angle, θ , Refer to figure as below.

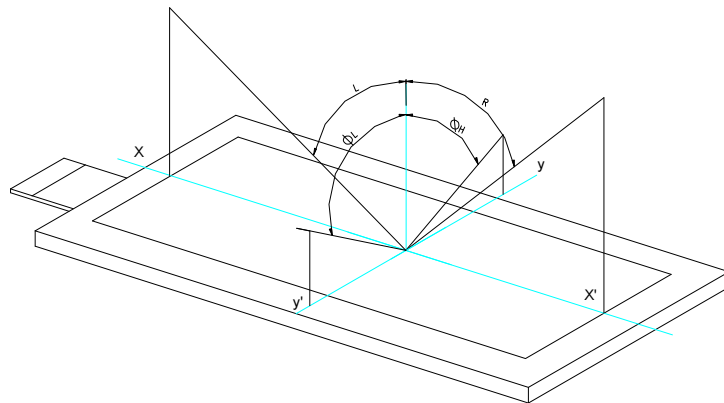

Note 6. Measured at the center area of the panel when all the input terminals of LCD panel are electrically opened.

Note 7: Luminance Uniformity of these 9 points is defined as below:

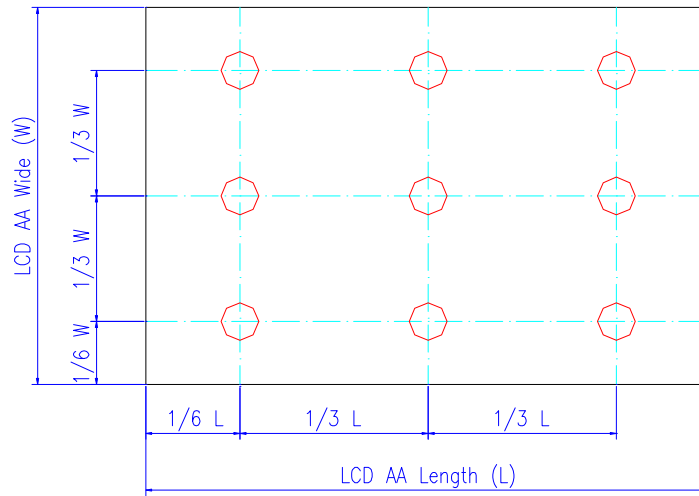

$$\text{Uniformity} = \frac{\text{minimum luminance in 9 points (1-9)}}{\text{maximum luminance in 9 points (1-9)}}$$

E. Touch Screen Panel Specifications

1. FPC Pin Assignment

Pin No.	Symbol	I/O	Description
37	Y2	I/O	Touch panel top electrode
38	X2	I/O	Touch panel left electrode
39	Y1	I/O	Touch panel bottom electrode
40	X1	I/O	Touch panel right electrode

2. Electrical Characteristics

Item	Min.	Typ	Max.	Unit	Remark	
Rate DC Voltage	--	--	7	V		
Resistance	X (Film)	500	--	1500	Ω	At connector
	Y (Glass)	200	--	900		
Linearity	-1.5%		1.5%	--	Note 1	
Response Time		—	20	ms		
Insulation Resistance	20			M Ω	DC 25V	

Note 1: Measurement condition of Linearity: difference between actual voltage & theoretical voltage is an error at any points. Linearity is the value max. error voltage divided by voltage difference on within T/P active area inside 2mm.

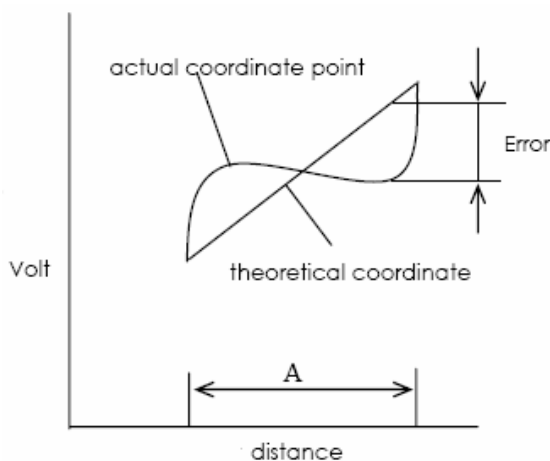

3. Mechanical Characteristics

Item	Min.	Max.	Unit	Remark
Hardness of Surface	3	--	H	JIS K-5600
activation force (Pen or Finger)		80	gf	Note 1, 2

Note 1: Within " active area inside 2mm", but not near the active area boundary and on the dot-spacer.

Note 2: Operation force measurement is under test condition as figure below.

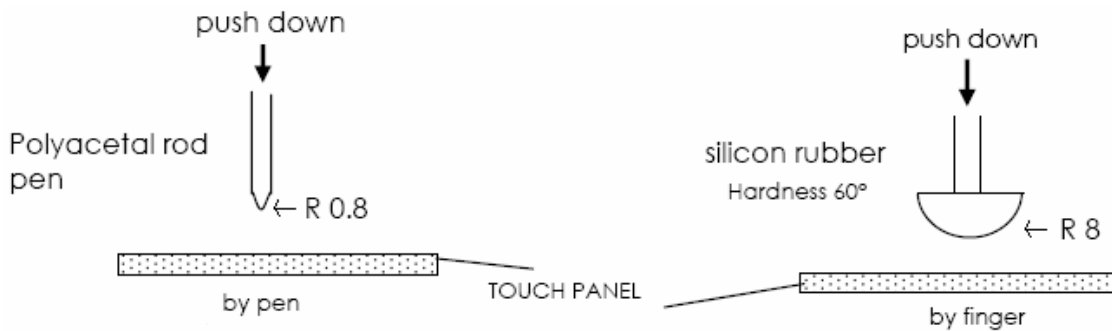

4. Life Test Condition

Item	Min.	Max.	Unit	Remark
Notes Life	10^5	--	lines	Note 1
Input Life	10^6	--	times	Note 2

Note 1: Notes Life test condition (by pen): slide on central 2/3 of active area and use R 0.8mm polyacetal pen, input force : 250gf, frequency : 60mm/sec. Sliding from A to B complete 1 time. shown as figure2.

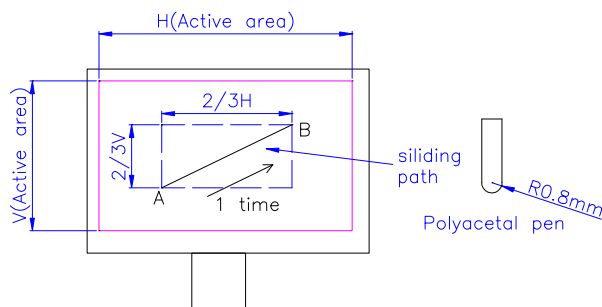

Note 2: Input Life test condition (by finger): test position on active area center and use R8.0mm silicon rubber (hardness 60°), test force: 250gf, frequency : 2times/sec. shown as figure.

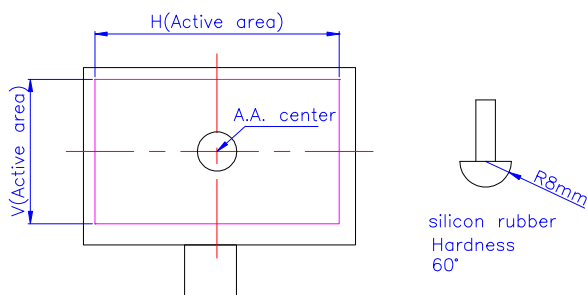

5. Attention

Please pay attention for below matters at mounting design of touch panel of LCD module.

- 1) Do not design casing opening area pressing the active area to prevent from miss input. Suggest casing opening area shown as mechanical drawing. Suggest the gap between casing and touch panel surface at least 0.5mm to avoid miss input.
- 2) Cushion area must not contact with active area. Suggest cushion area shown as mechanical drawing.
- 3) Use elastic or non-conductive material to enclosure touch panel.
- 4) Do not bond film of touch panel with casing.
- 5) The touch panel edge is conductive. Do not touch it with any conductive part after mounting.

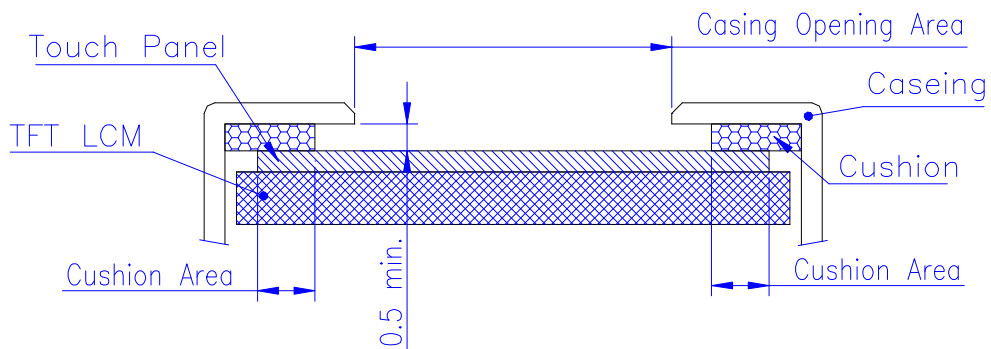

- 6) If user wants to cleaning touch panel by air gun, pressure 2kg/cm^2 below is suggested. Not to blow glass from FPC site to prevent FPC peeled off.
- 7) Do not put a heavy shock or stress on touch panel and film surface. Ex. Don't lift the panel by film face with vacuum.
- 8) Do not lift LCD module by FPC.
- 9) Please use dry cloth or soft cloth with neutral detergent (after wring dry) or one with ethanol at cleaning. Do not use any organic solvent, acid or alkali liquor.
- 10) Do not pile touch panel. Do not put heavy goods on touch panel.

F. Reliability Test Items

No.	Test items	Conditions	Remark
1	High Temperature Storage	Ta= 80□ 240Hrs	
2	Low Temperature Storage	Ta= -40□ 240Hrs	
3	High Ttemperature Operation	Tp= 70□ 240Hrs	
4	Low Temperature Operation	Ta= -20□ 240Hrs	
5	High Temperature & High Humidity	Tp= 60□. 90% RH 240Hrs	Operation
6	Heat Shock	-25□~70□, 50 cycle, 2Hrs/cycle	Non-operation
7	Electrostatic Discharge	Contact = ± 4 kV, class B Air = ± 8 kV, class B	Note 5
8	Vibration	Frequency range : 8~33.3Hz Stoke : 1.3mm Sweep : 2.9G ,33.3~400Hz 2 hours for each direction of X,Y,Z 4 hours for Y direction	Non-operation JIS C7021, A-10 condition A : 15 minutes
9	Mechanical Shock	100G . 6ms, ±X,±Y,±Z 3 times for each direction	Non-operation JIS C7021, A-7 condition C
10	Vibration (With Carton)	Random vibration: 0.015G ² /Hz from 5~200Hz -6dB/Octave from 200~500Hz	IEC 68-34
11	Drop (With Carton)	Height: 60cm 1 corner, 3 edges, 6 surfaces	
12	Pressure	5kg, 5sec	Note 7

Note 1: Ta: Ambient Temperature. Tp: Panel Surface Temperature

Note 2: In the standard conditions, there is not display function NG issue occurred. All the cosmetic specification is judged before the reliability stress.

Note 3: All the cosmetic specification is judged before the reliability stress.

Note 4: temperature and relative umidity range is shown in the figure below

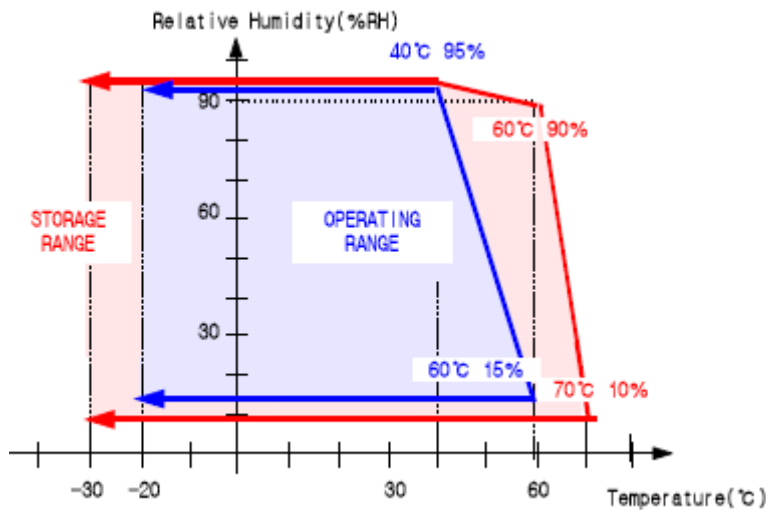

Note5 : All test techniques follow IEC6100-4-2 standard.

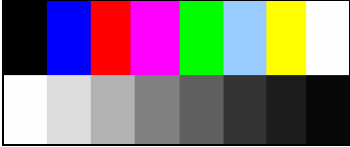
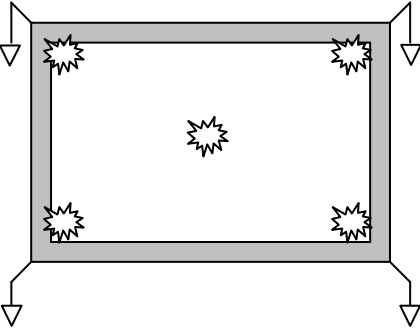
Test Condition			Note
<p>Pattern</p> 			
<p>Procedure And Set-up</p>	<p><u>Contact Discharge</u> : 330Ω, 150pF, 1sec, 5point, 10times/point <u>Air Discharge</u> : 330Ω, 150pF, 1sec, 5 point, 10times/point</p> 		
<p>Criteria</p>	<p>A – Normal operation. No degradation. No failures B – Some performance degradation allowed. No data lost. Self-recoverable. No hardware failures. C – Temporary performance degradation. Recovery by operator is acceptable. No hardware failures. D – Hardware failures.</p>		

Note 6:

1. The metal casing is connected to ground (0V) at four corners.
2. All register commands are repeating transferred.
3. Judging the result after discharging.

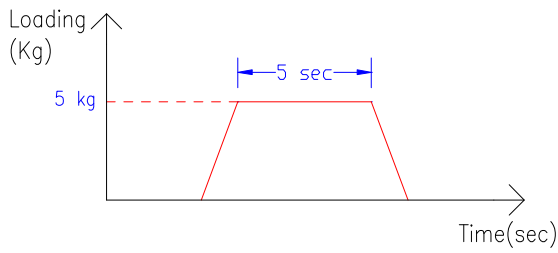
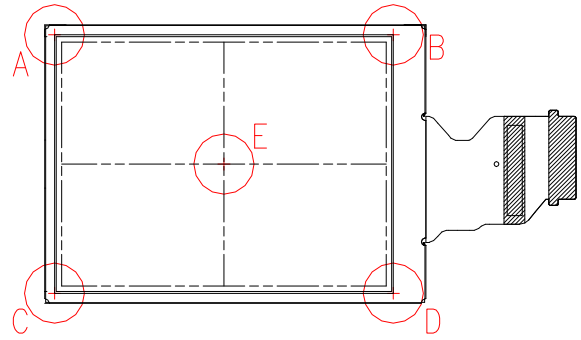
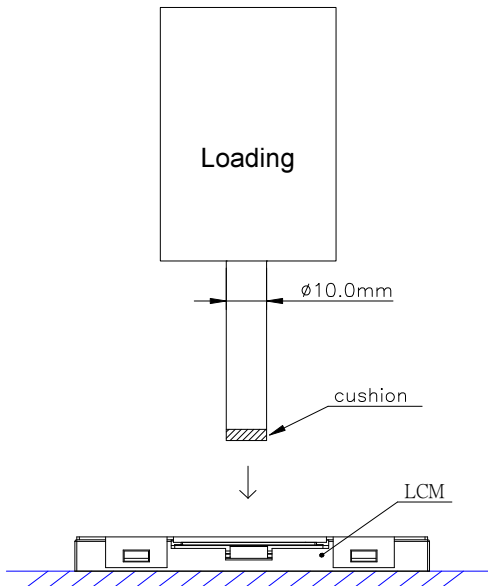

G. Packing and Marking

1. Packing Form

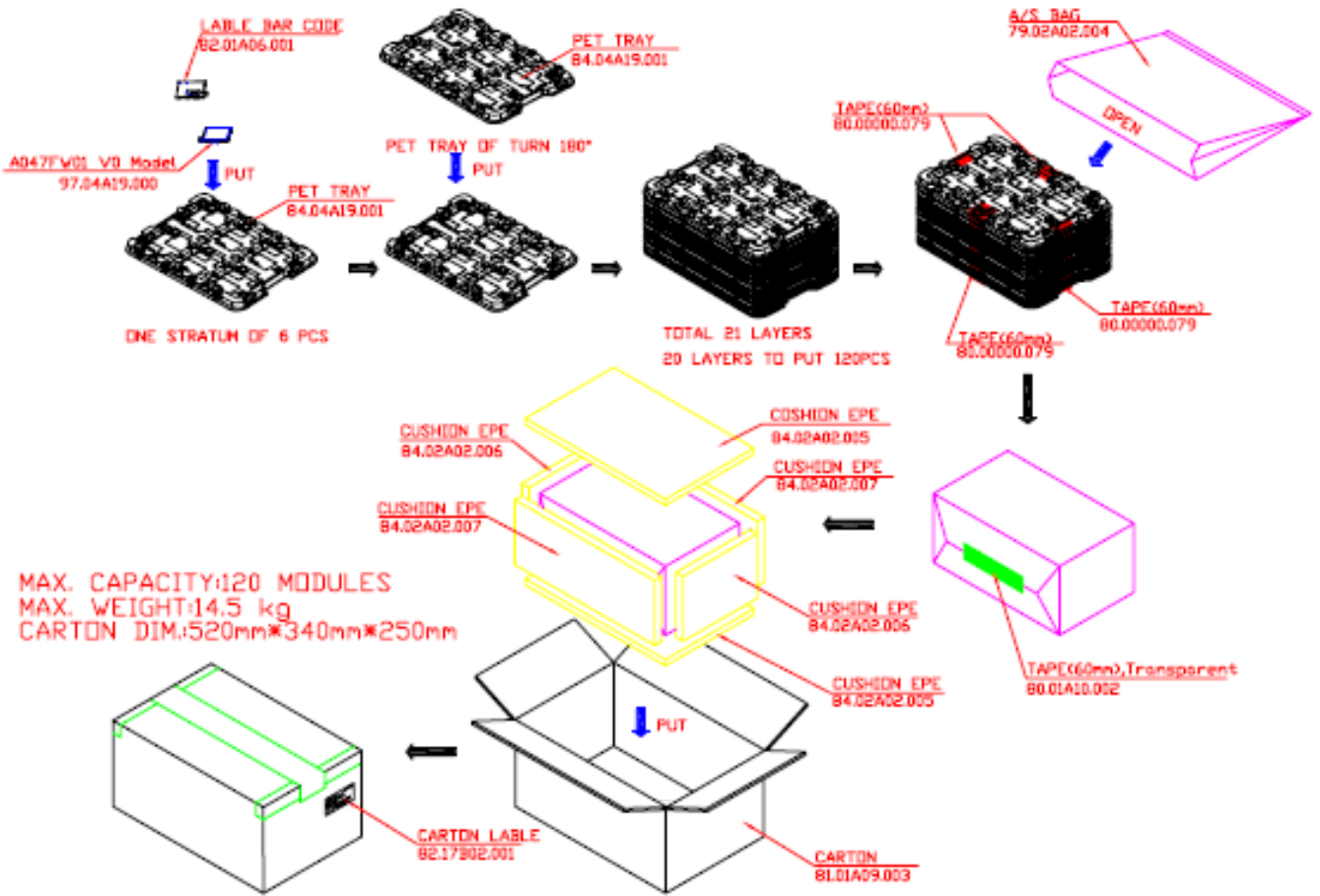

2. Module/Panel Label Information

The module/panel (collectively called as the “Product”) will be attached with a label of Shipping Number which represents the identification of the Product at a specific location. Refer to the Product outline drawing for detailed location and size of the label. The label is composed of a 9-digit serial number with the following definition:

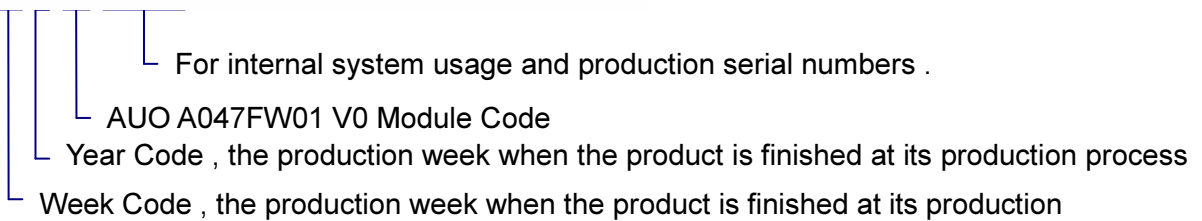

Example:

1690012AB:

Product Manufacturing Week Code: WK16

Product Manufacturing Year Code: Year 2009

3. Carton Label Information

The packing carton will be attached with a carton label where packing Q'ty, AUO Model Name, AUO Part Number, Customer Part Number (Optional) and a series of Carton Number in 13 or 14 digits are printed. The Carton Number is appearing in the following format:

ABC-DEFG-HIJK-LMN

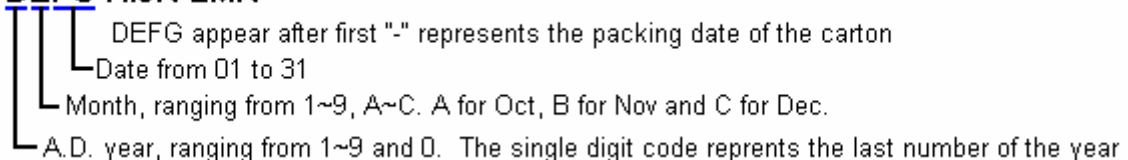

Refer to the drawing of packing format for the location and size of the carton label.

H. Precautions

1. Do not twist or bend the module and prevent the unsuitable external force for display module during assembly.
2. Adopt measures for good heat radiation. Be sure to use the module with in the specified temperature.
3. Avoid dust or oil mist during assembly.
4. Follow the correct power sequence while operating. Do not apply the invalid signal, otherwise, it will cause improper shut down and damage the module.
5. Less EMI: it will be more safety and less noise.
6. Please operate module in suitable temperature. The response time & brightness will drift by different temperature.
7. Avoid to display the fixed pattern (exclude the white pattern) in a long period, otherwise, it will cause image sticking.
8. Be sure to turn off the power when connecting or disconnecting the circuit.
9. Polarizer scratches easily, please handle it carefully.
10. Display surface never likes dirt or stains.
11. A dewdrop may lead to destruction. Please wipe off any moisture before using module.
12. Sudden temperature changes cause condensation, and it will cause polarizer damaged.
13. High temperature and humidity may degrade performance. Please do not expose the module to the direct sunlight and so on.
14. Acetic acid or chlorine compounds are not friends with TFT display module.
15. Static electricity will damage the module, please do not touch the module without any grounded device.
16. Do not disassemble and reassemble the module by self.
17. Be careful do not touch the rear side directly.
18. No strong vibration or shock. It will cause module broken.
19. Storage the modules in suitable environment with regular packing.
20. Be careful of injury from a broken display module.
21. Please avoid the pressure adding to the surface (front or rear side) of modules, because it will cause the display non-uniformity or other function issue.