



CUSTOMER APPROVAL SHEET

Company Name	
MODEL	A050FW02 V1
CUSTOMER APPROVED	Title : Name :

- APPROVAL FOR SPECIFICATIONS ONLY (Spec. Ver.____)
- APPROVAL FOR SPECIFICATIONS AND ES SAMPLE (Spec. Ver.____)
- APPROVAL FOR SPECIFICATIONS AND CS SAMPLE (Spec. Ver.____)
- CUSTOMER REMARK :

AUO PM :

P/N : 91.05A10.100

Comment :



Doc. version :	0.0
Total pages :	18
Date :	2009/04/22

Product Specification

5.0" COLOR TFT-LCD MODULE/PANEL

MODEL NAME: A050FW02 V1

Planned Lifetime:	From 2009/May To 2010/Jun
Phase-out Control:	From 2010/Mar To 2010/Jun
EOL Schedule:	2010/Jun

< >Preliminary Specification

<◆>Final Specification

Note: The content of this specification is subject to change.

© 2009 AU Optonics
All Rights Reserved,
Do Not Copy.



Record of Revision

Version	Revise Date	Page	Content
0.0	2009/04/22		First Draft

Contents

A. General Information	3
B. Outline Dimension	4
1. TFT-LCD Module – Front View	4
2. TFT-LCD Module – Rear View	5
C. Electrical Specifications	6
1. TFT LCD Panel Pin Assignment	6
2. Absolute Maximum Ratings	7
3. Electrical DC Characteristics	7
4. Electrical AC Characteristics	8
5. Power On/Off Characteristics	10
D. Optical Specification	11
E. Reliability Test Items	13
F. Packing and Marking	15
1. Packing Form	15
G. Precautions	16

A. General Information

This product is for portable PND application.

NO.	Item	Unit	Specification	Remark
1	Screen Size	inch	5.0(Diagonal)	
2	Display Resolution	dot	480RGB(H)×272(V)	
3	Overall Dimension	mm	116.5(H) × 71.8(V) × 1.0(T)	Note 1
4	Active Area	mm	110.88(H)×62.832(V)	
5	Pixel Pitch	mm	0.077(H)×0.231(V)	
6	Color Configuration	--	R. G. B. Stripe	Note 2
7	Color Depth	--	16.7M Colors	Note 3
8	NTSC Ratio	%	54	
9	Display Mode	--	Normally White	
10	Panel surface Treatment	--	Anti-Glare, 3H	
11	Weight	g	18.1	
12	Panel Power Consumption	W	TBD	Note 4
13	Backlight Power Consumption	mW	N/A	
14	Viewing direction		6 o'clock (gray inversion)	

Note 1: Not include backlight cable and FPC. Refer next page to get further information.

Note 2: Below figure shows dot stripe arrangement.

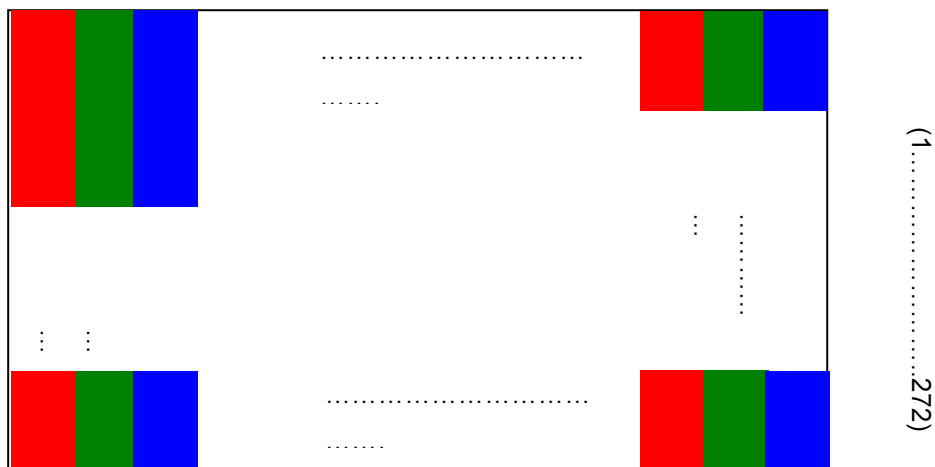

Note 3: The full color display depends on 24-bit data signal (pin 5~28).

Note 4: Please refer to Electrical Characteristics chapter.

B. Outline Dimension – Front View

1. TFT-LCD Module – Front View

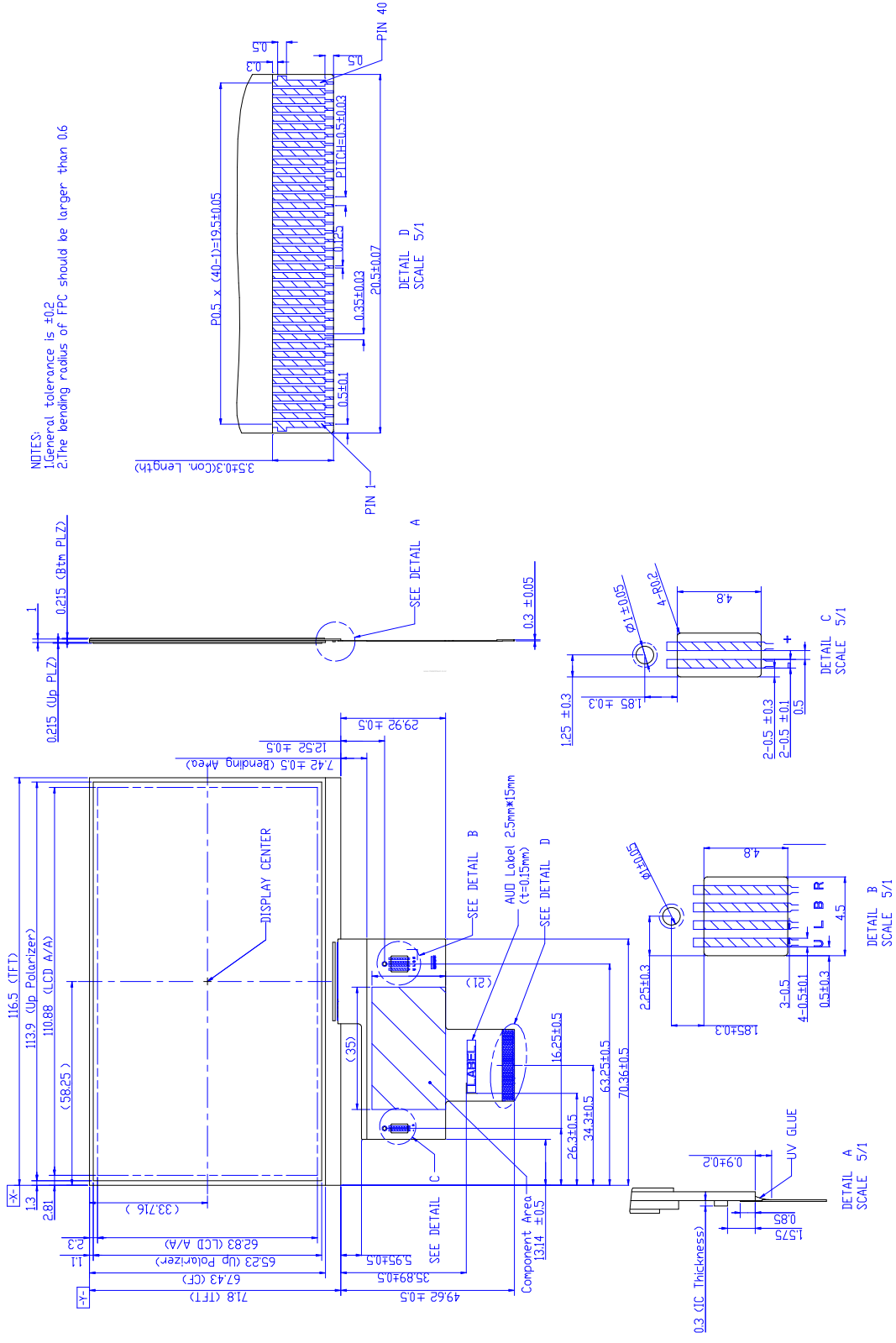

2. TFT-LCD Module – Rear View

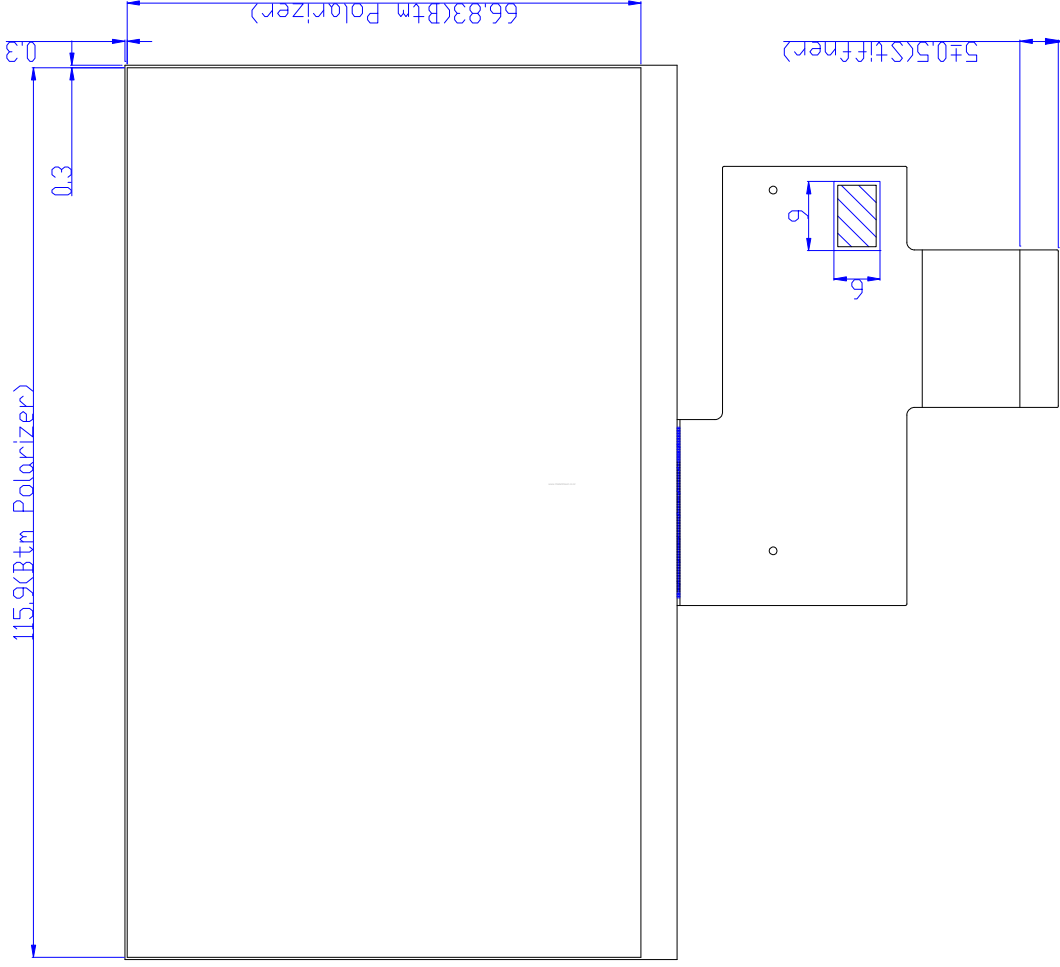

C. Electrical Specifications

1. TFT LCD Panel Pin Assignment

Recommended connector : FH12-40S-0.5SH

No.	Pin Name	I/O	Description	Remarks
1	VLED-	PI	LED backlight cathode	
2	VLED+	PI	LED backlight anode	
3	GND	G	Ground	
4	VDD	PI	Power Supply	
5	R0	I	Red Data (LSB)	
6	R1	I	Red Data	
7	R2	I	Red Data	
8	R3	I	Red Data	
9	R4	I	Red Data	
10	R5	I	Red Data	
11	R6	I	Red Data	
12	R7	I	Red Data (MSB)	
13	G0	I	Green Data (LSB)	
14	G1	I	Green Data	
15	G2	I	Green Data	
16	G3	I	Green Data	
17	G4	I	Green Data	
18	G5	I	Green Data	
19	G6	I	Green Data	
20	G7	I	Green Data (MSB)	
21	B0	I	Blue Data (LSB)	
22	B1	I	Blue Data	
23	B2	I	Blue Data	
24	B3	I	Blue Data	
25	B4	I	Blue Data	
26	B5	I	Blue Data	
27	B6	I	Blue Data	
28	B7	I	Blue Data (MSB)	
29	GND	G	Ground	
30	DCLK	I	Pixel Clock	
31	DISP	I	Display On/Off Signal	
32	NC		Not Connected	
33	NC		Not Connected	

No.	Pin Name	I/O	Description	Remarks
34	DE	I	Data Enable	
35	NC		Not Connected	
36	GND	G	Ground	
37	TP_R	I/O	Touch Panel Right Signal	
38	TP_B	I/O	Touch Panel Bottom Signal	
39	TP_L	I/O	Touch Panel Left Signal	
40	TP_U	I/O	Touch Panel Up Signal	

I: Digital signal input, I/O: Touch Panel input and output signal, G: GND, PI: Power input

2. Absolute Maximum Ratings

Item	Symbol	Condition	Min.	Max.	Unit	Remark
Analog Power Voltage	VDD	GND=0	-0.3	5	V	
Input signal voltage	Data	GND=0	-0.3	3.6	V	Digital Signals

Note 1: Functional operation should be restricted under ambient temperature (25°C).

Note2: Maximum ratings are those values beyond which damages to the device may occur. Functional operation should be restricted to the limits in the Electrical Characteristics chapter.

3. Electrical DC Characteristics

a. Typical Operation Condition (AGND =GND = 0V)

Item	Symbol	Min.	Typ.	Max.	Unit	Remark
Analog and Digital Power Voltage	VDD	3.0	3.3	3.6	V	
Digital Input Signal Voltage	H Level	V_{IH}	$0.7 \times V_{DD}$	--	VDD	V
	L Level	V_{IL}	GND	--	$0.3 \times V_{DD}$	V

b. Current Consumption (AGND=GND=0V)

Parameter	Symbol	Condition	Min.	Typ.	Max.	Unit	Remark
Input Current for VDD	I_{VDD}	VDD=3.3V	-	15	-	mA	Note 1, 2
	I_{VDD} (STANDBY)	VDD=3.3V	-	15		uA	Note 3

Note 1: Test Condition is under typical Electrical DC and AC characteristics.

Note 2: Test pattern is the following picture.

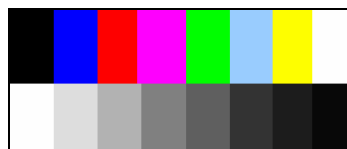

Note 3: In standby mode, all digital signals are stopped. Ex. DCLK, HSYNC ..etc.

4. Electrical AC Characteristics

a. Signal AC Characteristics

Parameter	Symbol	Min.	Typ.	Max.	Unit	Remark
DCLK clock time	T_{clk}	83	-	-	ns	Parallel RGB Mode
DE setup time	t_{desu}	12	-	-	ns	
DE hold time	t_{dehd}	12	-	-	ns	
Data setup time	t_{dst}	12	-	-	ns	
Data hold time	t_{dhd}	12	-	-	ns	

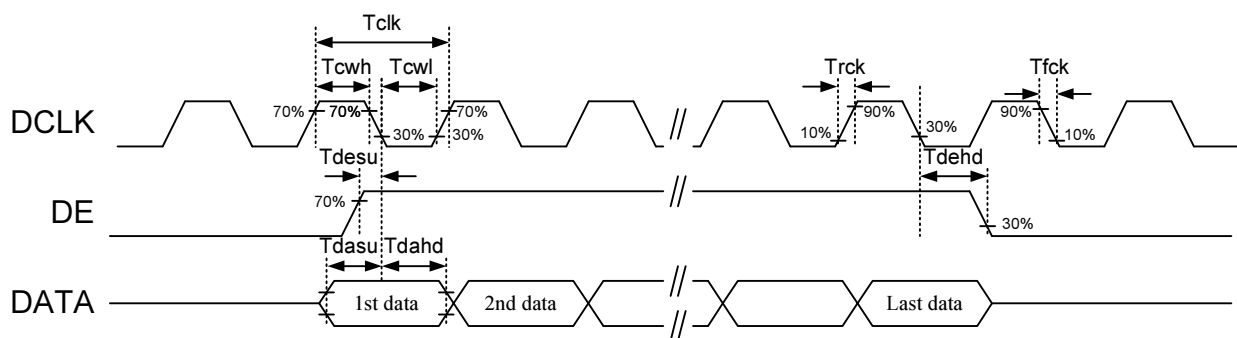

b. Input Timing

Vertical Timing of Input

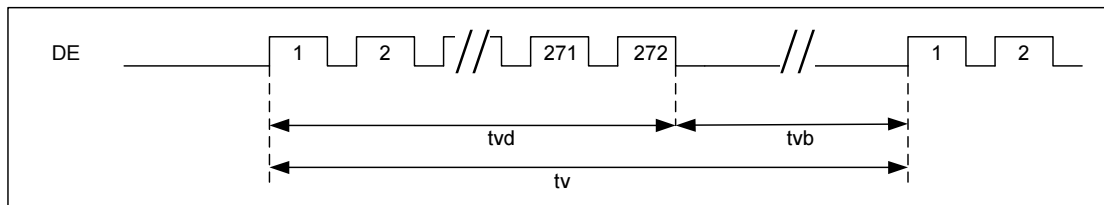

Horizontal Timing of Input

Parallel RGB Mode Data format

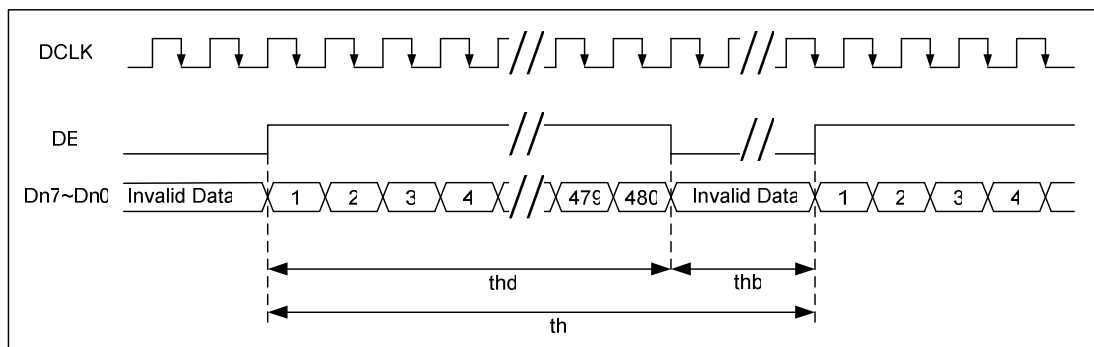

Parallel RGB input timing Parameter

PARAMETER	Symbol	Min	Typ	Max	Unit
Clock cycle	1/tc	-	9	15	MHz
Horizontal cycle	1/fh	-	17.14	-	KHz
Vertical cycle	1/fv	-	59.94	-	Hz
Horizontal Signal					
Horizontal cycle *1	th	-	525	-	DCLK
Horizontal display period	thd	-	480	-	DCLK
Horizontal blank	thb	-	45	-	DCLK
Vertical Signal					
Vertical cycle	tv	-	288	-	H
Vertical display period	tvd	-	272	-	H
Vertical blank	tvb	-	16	-	H

5. Power On/Off Characteristics

a. Recommended Power On Sequence

The LCD adopts high voltage driver IC, so it could be permanently damaged under a wrong power on/off sequence. The suggested LCD power sequence is below :

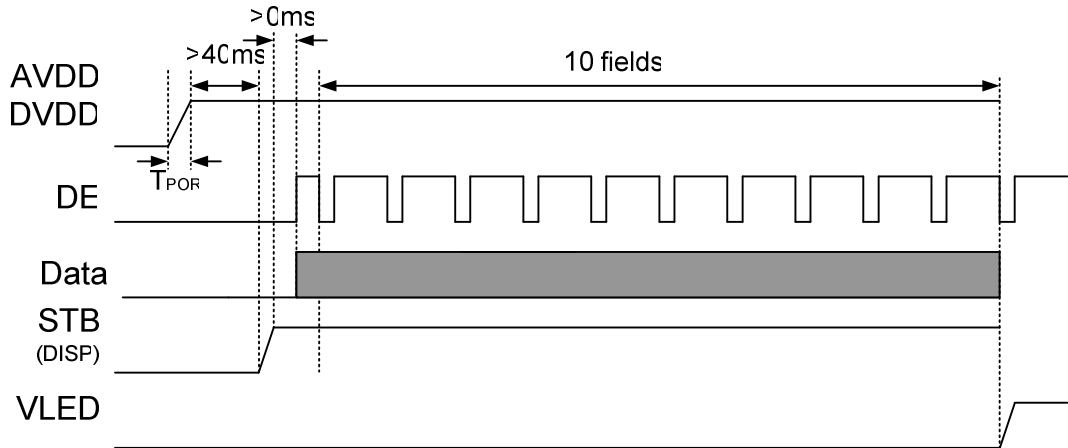

b. Recommended Power Off Sequence

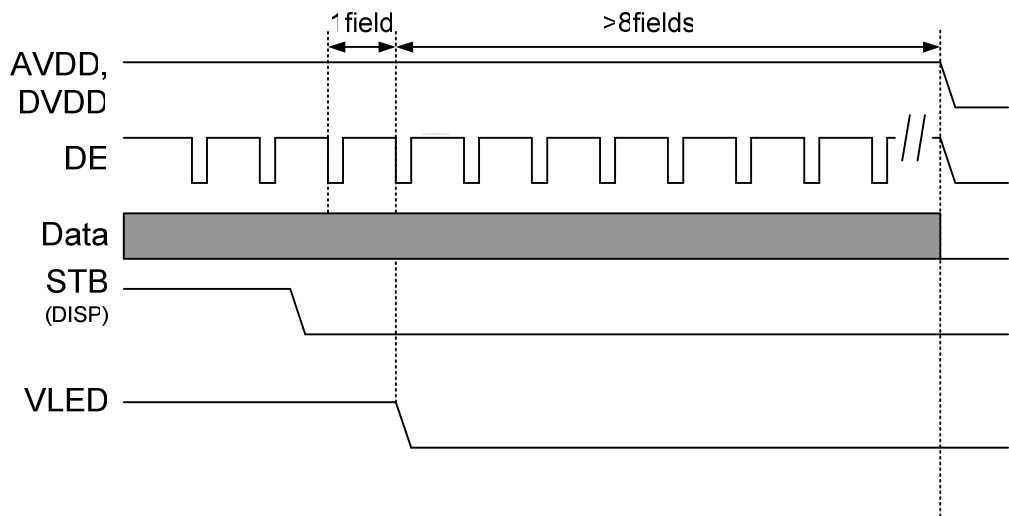

Notes: IC internal default setting STB="1", Normal operation

D. Optical Specification

All optical specification is measured under typical condition (Note 1, 2)

Item	Symbol	Condition	Min.	Typ.	Max.	Unit	Remark
Response Time							
Rise	Tr	$\theta=0^\circ$	--	7	--	ms	Note 3
Fall	Tf		--	23	--	ms	
Contrast ratio	CR	At optimized viewing angle	200	300	--		Note 4
Viewing Angle							
Top		$CR \geq 10$	35	50	--	deg.	Note 5
Bottom			50	65	--		
Left			50	65	--		
Right			50	65	--		
Chromaticity	White	X	$\theta=0^\circ$		TBD		
		Y	$\theta=0^\circ$		TBD		
	Red	X	$\theta=0^\circ$		TBD		
		Y	$\theta=0^\circ$		TBD		
	Green	X	$\theta=0^\circ$		TBD		
		Y	$\theta=0^\circ$		TBD		
	Blue	X	$\theta=0^\circ$		TBD		
		Y	$\theta=0^\circ$		TBD		
Transmittance	%	$\theta=0^\circ$		7		%	Note 2

Note 1: Ambient temperature =25°C, and LED lightbar voltage $V_L = 12$ V. To be measured in the dark room.

Note 2: To be measured on the center area of panel with a viewing cone of 1° by Topcon luminance meter BM-5A, after 15 minutes operation.

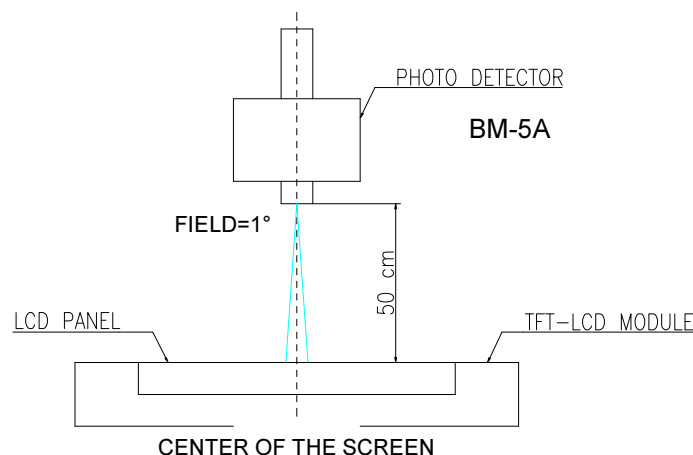

Note 3: Definition of response time:

The output signals of photo detector are measured when the input signals are changed from “black” to “white”(falling time) and from “white” to “black”(rising time), respectively.

The response time is defined as the time interval between the 10% and 90% of amplitudes. Refer to figure as below.

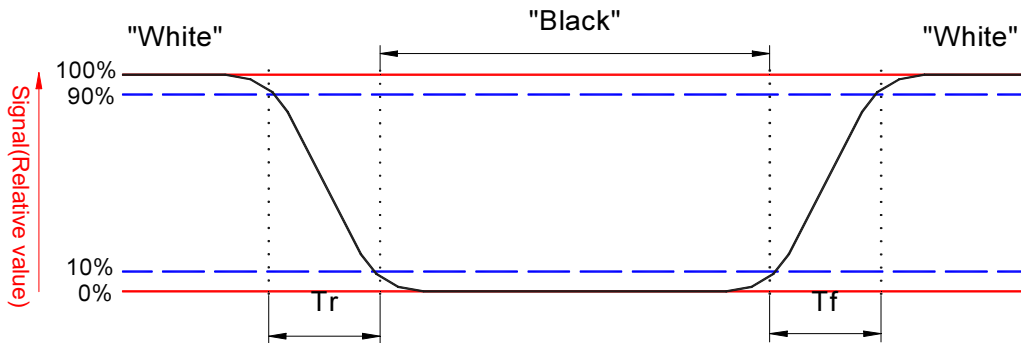

Note 4. Definition of contrast ratio:

Contrast ratio is calculated with the following formula.

$$\text{Contrast ratio (CR)} = \frac{\text{Photo detector output when LCD is at "White" status}}{\text{Photo detector output when LCD is at "Black" status}}$$

Note 5. Definition of viewing angle, θ , Refer to figure as below.

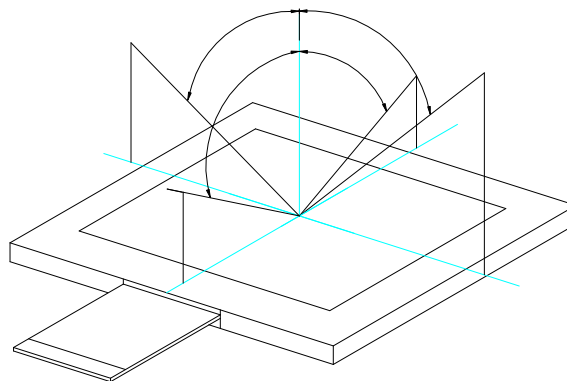

E. Reliability Test Items

No.	Test items	Conditions	Remark
1	High Temperature Storage	Ta= 80°C 240Hrs	
2	Low Temperature Storage	Ta= -40°C 240Hrs	
3	High Temperature Operation	Tp= 70°C 240Hrs	
4	Low Temperature Operation	Ta= -30°C 240Hrs	
5	High Temperature & High Humidity	Tp= 60°C, 90% RH 240Hrs	Operation
6	Heat Shock	-30°C~60°C, 50 cycle, 2Hrs/cycle	Non-operation
7	Electrostatic Discharge	Contact = ± 4 kV, class B Air = ± 8 kV, class B	Note 5
8	Image Sticking	25°C, 4hrs	Note 6
9	Vibration	Frequency range : 8~33.3Hz Stoke : 1.3mm Sweep : 2.9G, 33.3~400Hz 2 hours for each direction of X,Y,Z 4 hours for Y direction	Non-operation JIS C7021, A-10 condition A : 15 minutes
10	Mechanical Shock	100G . 6ms, ±X,±Y,±Z 3 times for each direction	Non-operation JIS C7021, A-7 condition C
11	Vibration (With Carton)	Random vibration: 0.015G ² /Hz from 5~200Hz -6dB/Octave from 200~500Hz	IEC 68-34
12	Drop (With Carton)	Height: 60cm 1 corner, 3 edges, 6 surfaces	

Note 1: Ta: Ambient Temperature. Tp: Panel Surface Temperature

Note 2: In the standard conditions, there is not display function NG issue occurred. All the cosmetic specification is judged before the reliability stress.

Note 3: All the cosmetic specification is judged before the reliability stress.

Note5 : All test techniques follow IEC6100-4-2 standard.

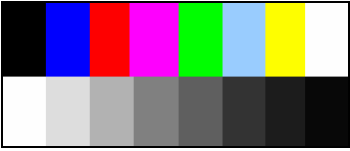
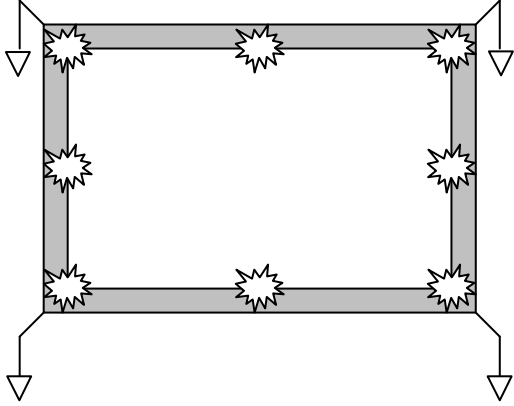
Test Condition		
<p>Pattern</p>		
<p>Procedure And Set-up</p>	<p>Contact Discharge : 330Ω, 150pF, 1sec, 8 point, 25times/point Air Discharge : 330Ω, 150pF, 1sec, 8 point, 25times/point</p> 	
<p>Criteria</p>	<p>B – Some performance degradation allowed. No data lost. Self-recoverable hardware failure.</p>	
<p>Others</p>	<p>1. Gun to Panel Distance 2. No SPI command, keep default register settings.</p>	

Note 6: Operate with chess board pattern as figure and lasting time and temperature as the conditions.

Then judge with 50% gray level, the mura is less than JND 2.5

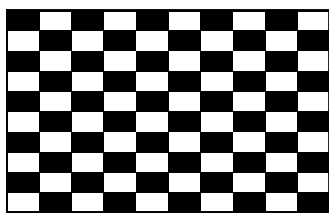

F. Packing and Marking

1. Packing Form

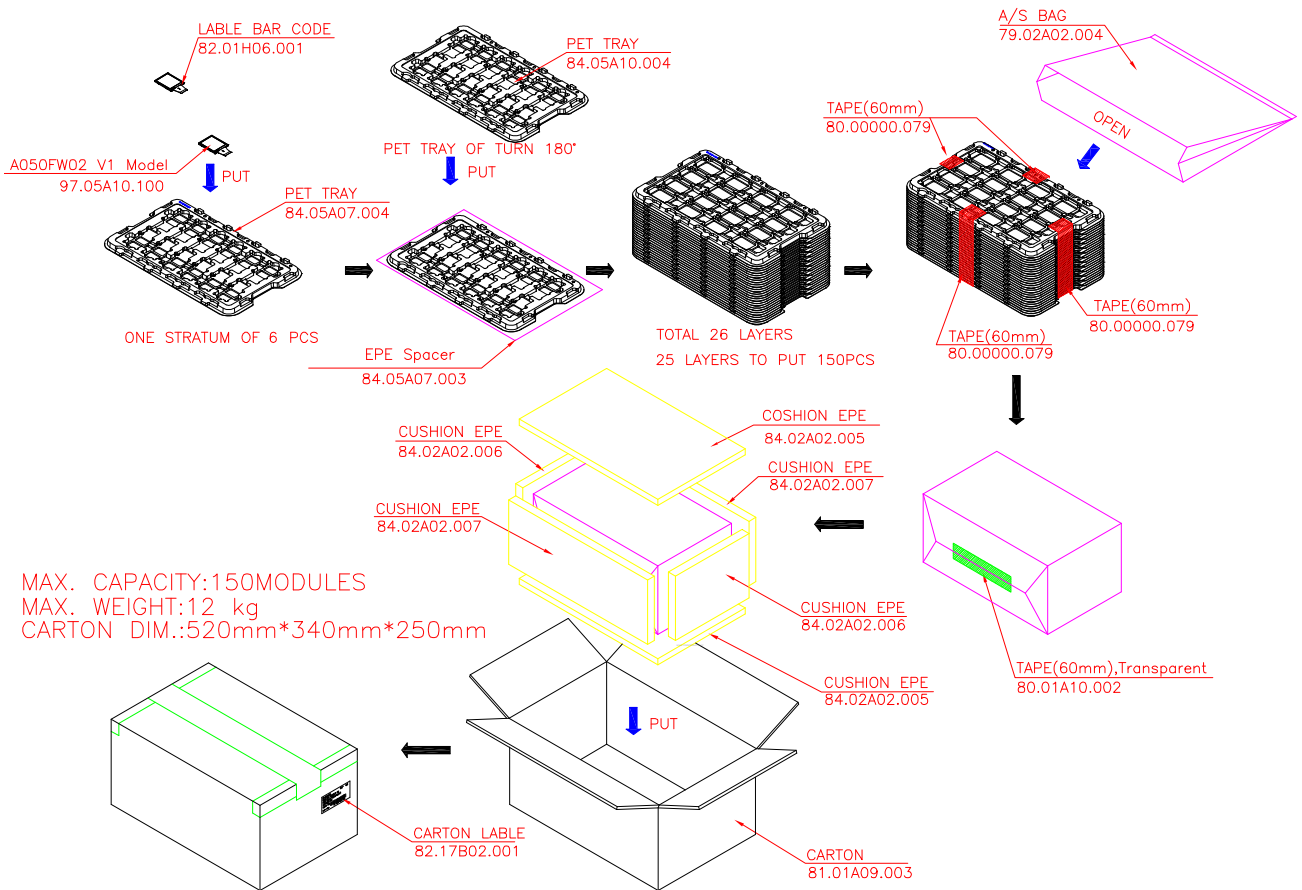

G. Precautions

1. Do not twist or bend the module and prevent the unsuitable external force for display module during assembly.
2. Adopt measures for good heat radiation. Be sure to use the module with in the specified temperature.
3. Avoid dust or oil mist during assembly.
4. Follow the correct power sequence while operating. Do not apply the invalid signal, otherwise, it will cause improper shut down and damage the module.
5. Less EMI: it will be more safety and less noise.
6. Please operate module in suitable temperature. The response time & brightness will drift by different temperature.
7. Avoid to display the fixed pattern (exclude the white pattern) in a long period, otherwise, it will cause image sticking.
8. Be sure to turn off the power when connecting or disconnecting the circuit.
9. Polarizer scratches easily, please handle it carefully.
10. Display surface never likes dirt or stains.
11. A dewdrop may lead to destruction. Please wipe off any moisture before using module.
12. Sudden temperature changes cause condensation, and it will cause polarizer damaged.
13. High temperature and humidity may degrade performance. Please do not expose the module to the direct sunlight and so on.
14. Acetic acid or chlorine compounds are not friends with TFT display module.
15. Static electricity will damage the module, please do not touch the module without any grounded device.
16. Do not disassemble and reassemble the module by self.
17. Be careful do not touch the rear side directly.
18. No strong vibration or shock. It will cause module broken.
19. Storage the modules in suitable environment with regular packing.
20. Be careful of injury from a broken display module.
21. Please avoid the pressure adding to the surface (front or rear side) of modules, because it will cause the display non-uniformity or other function issue.