



CUSTOMER APPROVAL SHEET

| | |
|-------------------|-------------------|
| Company Name | |
| MODEL | A050FW02 V2 |
| CUSTOMER APPROVED | Title : Name : |

- APPROVAL FOR SPECIFICATIONS ONLY (Spec. Ver.)
- APPROVAL FOR SPECIFICATIONS AND ES SAMPLE (Spec. Ver.)
- APPROVAL FOR SPECIFICATIONS AND CS SAMPLE (Spec. Ver.)
- CUSTOMER REMARK :

P/N : 97.05A10.200

: 97.05A10.201

Comment :



| | |
|----------------|------------|
| Doc. version : | 0.7 |
| Total pages : | 26 |
| Date : | 2009/10/05 |

Product Specification

5" COLOR TFT-LCD MODULE/PANEL

MODEL NAME: A050FW02 V2

97.05A10.200

97.05A10.201

< >Preliminary Specification

<□>Final Specification

Note: The content of this specification is subject to change.

© 2009 AU Optronics
All Rights Reserved,
Do Not Copy.

Record of Revision

| Version | Revise Date | Page | Content |
|---------|-------------|---------------|---|
| 0.0 | | | First Draft |
| 0.1 | 2009/4/22 | 5,6 | Modify pin NO. of SPI interface |
| 0.2 | 2009/5/12 | 4 6 | 1)Drawing update 2)Pin 36 : HV mode or DE mode control signal |
| 0.3 | 2009/7/07 | 4 22 | 1)Drawing update : white-line mark change of connect 2) Reliability Test Items : pressure test |
| 0.4 | 2009/7/16 | 4 12 17 | 1) Drawing update 2)Serial Command Setting 3)RGB chromaticity update |
| 0.5 | 2009/8/12 | 4 12 20 | 1)Drawing update : conductive copper tape 2)Suggested Serial Command Settings 3)touch panel : operation force |
| 0.6 | 2009/09/07 | 17 | chromaticity tolerance from +/- 0.05 to +/- 0.04 |
| 0.7 | 2009/10/05 | 4 26 12 | Drawing update:insulation tape Ordering information for touch panel Suggested Serial Command Settings |
| | | | |
| | | | |
| | | | |

Contents

| | |
|---|-----------|
| A. General Information | 3 |
| B. Outline Dimension | 4 |
| 1. TFT-LCD Module – Front and Rear View | 4 |
| C. Electrical Specifications | 5 |
| 1. TFT LCD Panel Pin Assignment | 5 |
| 2. Absolute Maximum Ratings | 6 |
| 3. Electrical DC Characteristics | 7 |
| 4. Electrical AC Characteristics | 8 |
| 5. Serial Interface Characteristics | 10 |
| 6. Power On/Off Characteristics | 16 |
| D. Optical Specification | 17 |
| E. Touch Screen Panel Specifications | 19 |
| 1. FPC Pin Assignment | 19 |
| 2. Electrical Characteristics | 19 |
| 3. Mechanical Characteristics | 20 |
| 4. Life Test Condition | 20 |
| 5. Attention | 21 |
| F. Reliability Test Items | 22 |
| G. Packing and Marking | 24 |
| 1. Packing Form | 24 |
| H. Precautions | 25 |
| I. Ordering Information: | 26 |

A. General Information

This product is for portable PND and digital photo frame application.

| NO. | Item | Unit | Specification | Remark |
|-----|-------------------------|------|------------------------------|--------|
| 1 | Screen Size | inch | 5.0(Diagonal) | |
| 2 | Display Resolution | dot | 480RGB (H) X 272 (V) | |
| 3 | Overall Dimension | mm | 120.7(H) X 75.8(V) X 4.25(T) | Note 1 |
| 4 | Active Area | mm | 110.88 (H) X 62.832 (V) | |
| 5 | Pixel Pitch | mm | 0.231 (H) X 0.231 (V) | |
| 6 | Color Configuration | -- | R. G. B. Stripe | Note 2 |
| 7 | Color Depth | -- | 16.7M Colors | Note 3 |
| 8 | NTSC Ratio (Cell) | % | 54 | |
| 9 | Display Mode | -- | Normally White | |
| 10 | Panel surface Treatment | -- | Anti-Glare, 3H | |
| 11 | Weight | g | 75 | |
| 12 | Power Consumption | mW | 930 | Note 4 |
| 13 | Viewing direction | | 6 o'clock (gray inversion) | |

Note 1: Not include backlight cable and FPC. Refer next page to get further information.

Note 2: Below figure shows dot stripe arrangement.

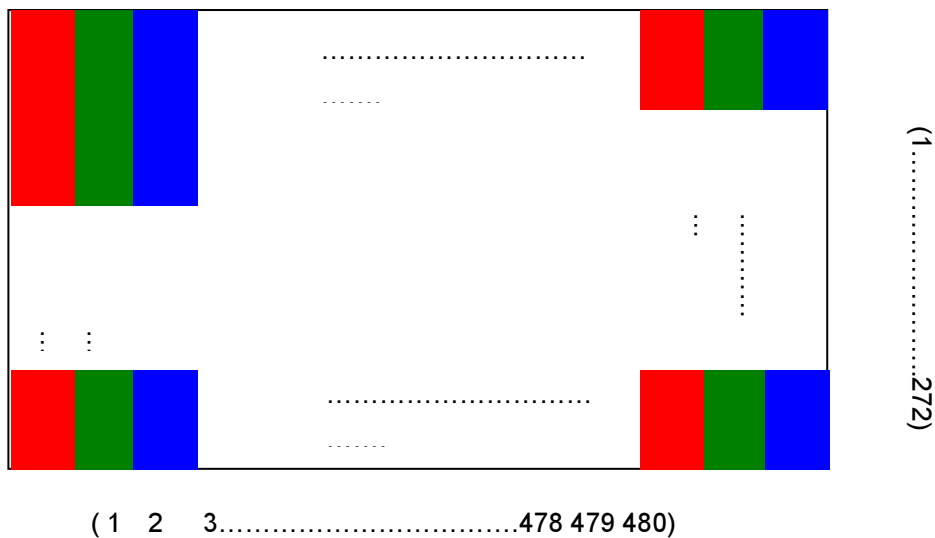

Note 3: The full color display depends on 24-bit data signal.

Note 4: Please refer to Electrical Characteristics chapter.

B. Outline Dimension

1. TFT-LCD Module – Front and Rear View

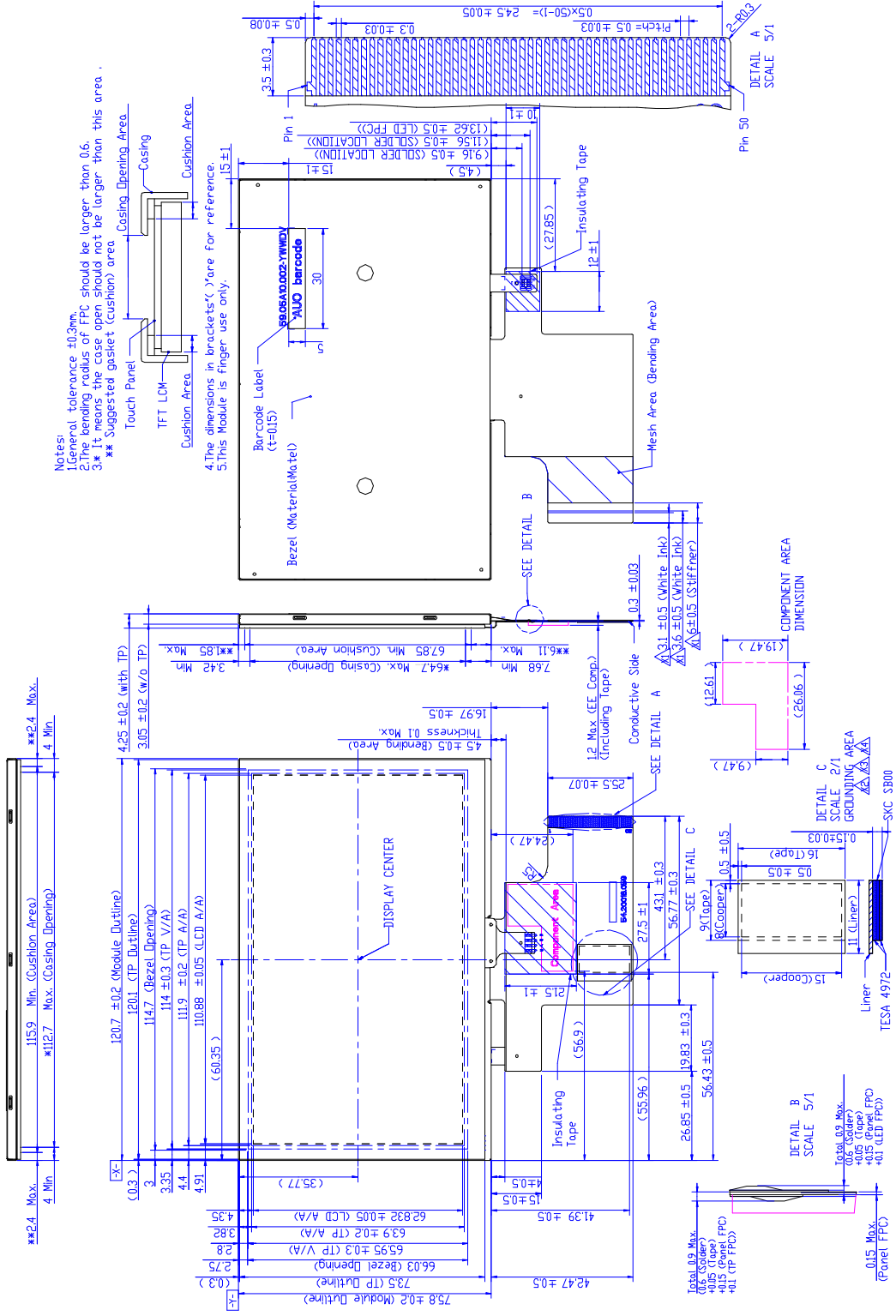

C. Electrical Specifications

1. TFT LCD Panel Pin Assignment

Recommended connector: 6702-E50N-00R

| No. | Pin Name | I/O | Description | Remarks |
|-----|----------|-----|------------------------------------|---------|
| 1 | GND | G | GND | |
| 2 | GND | G | GND | |
| 3 | AVDD | PI | Power supply for analog circuit | |
| 4 | DVDD | PI | Power supply for digital interface | |
| 5 | R0 | I | Red Data Signal (LSB) | |
| 6 | R1 | I | Red Data Signal | |
| 7 | R2 | I | Red Data Signal | |
| 8 | R3 | I | Red Data Signal | |
| 9 | R4 | I | Red Data Signal | |
| 10 | R5 | I | Red Data Signal | |
| 11 | R6 | I | Red Data Signal | |
| 12 | R7 | I | Red Data Signal (MSB) | |
| 13 | G0 | I | Green Data Signal (LSB) | |
| 14 | G1 | I | Green Data Signal | |
| 15 | G2 | I | Green Data Signal | |
| 16 | G3 | I | Green Data Signal | |
| 17 | G4 | I | Green Data Signal | |
| 18 | G5 | I | Green Data Signal | |
| 19 | G6 | I | Green Data Signal | |
| 20 | G7 | I | Green Data Signal (MSB) | |
| 21 | B0 | I | Blue Data Signal (LSB) | |
| 22 | B1 | I | Blue Data Signal | |
| 23 | B2 | I | Blue Data Signal | |
| 24 | B3 | I | Blue Data Signal | |
| 25 | B4 | I | Blue Data Signal | |
| 26 | B5 | I | Blue Data Signal | |
| 27 | B6 | I | Blue Data Signal | |
| 28 | B7 | I | Blue Data Signal (MSB) | |
| 29 | GND | G | GND | |
| 30 | DCLK | I | Pixel clock | |
| 31 | CSB | I | 3-wire I/F chip select pin | |
| 32 | HSYNC | I | Horizontal synchronizing signal | |
| 33 | VSYNC | I | Vertical synchronizing signal | |
| 34 | DE | I | Data enable | |
| 35 | GND | G | GND | |

| No. | Pin Name | I/O | Description | Remarks |
|-----|----------|-----|--|---------|
| 36 | HVDSL | I | HV mode or DE mode control signal. HVDSL="H": Set under HV mode, VSD and HSD signal must be provide by system. HVDSL="L": Set under DE mode, DE signal must be provided by system. | |
| 37 | NC | | No connect | |
| 38 | SCL | I | 3-wire I/F clock input pin | |
| 39 | SDA | I | 3-wire I/F data input pin | |
| 40 | GND | G | GND | |
| 41 | TP_R | I/O | X Right | |
| 42 | TP_B | I/O | Y Bottom | |
| 43 | TP_L | I/O | X Left | |
| 44 | TP_U | I/O | Y Up | |
| 45 | GND | G | GND | |
| 46 | VLED- | PI | LED backlight cathode | |
| 47 | NC | - | No connect | |
| 48 | VLED+ | PI | LED backlight anode | |
| 49 | GND | G | GND | |
| 50 | GND | G | GND | |

I: Digital signal input, O: Digital signal output, G: GND, PI: Power input, C: Capacitor

2. Absolute Maximum Ratings

| Item | Symbol | Condition | Min. | Max. | Unit | Remark |
|----------------------|--------|-----------|------|------|------|-----------------|
| Analog Power Voltage | AVDD | GND=0 | -0.3 | 5 | V | |
| Logic Power Voltage | DVDD | GND=0 | -0.5 | 5 | V | |
| Input signal voltage | Data | GND=0 | -0.3 | 3.6 | V | Digital Signals |

Note 1: Functional operation should be restricted under ambient temperature (25°C).

Note2: Maximum ratings are those values beyond which damages to the device may occur. Functional operation should be restricted to the limits in the Electrical Characteristics chapter.

3. Electrical DC Characteristics

a. Typical Operation Condition (GND = 0V)

| Item | Symbol | Min. | Typ. | Max. | Unit | Remark |
|---------------------------------|---------|----------|-------------------|------|-------------------|--------|
| Analog Power Voltage | AVDD | 3.0 | 3.3 | 3.6 | V | |
| Digital interface Power Voltage | DVDD | 1.7 | - | VDD | V | |
| Digital Input | H Level | V_{IH} | $0.7 \times DVDD$ | -- | DVDD | V |
| Signal Voltage | L Level | V_{IL} | GND | -- | $0.3 \times DVDD$ | V |

b. Current Consumption (GND=0V)

| Parameter | Symbol | Condition | Min. | Typ. | Max. | Unit | Remark |
|------------------------|------------------------|-----------|------|------|------|------|-----------|
| Input Current for AVDD | I_{VDD} | AVDD=3.3V | - | 15 | 18 | mA | Note 1, 2 |
| | I_{VDD} (STANDBY) | AVDD=3.3V | - | 15 | 20 | uA | Note 3 |

Note 1: Test Condition is under typical Electrical DC and AC characteristics.

Note 2: Test pattern is the following picture.

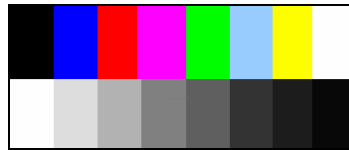

Note 3: In standby mode, all digital signals are stopped. Ex. DCLK, DE ..etc.

c. Backlight Driving Conditions

The backlight (LED module, Note 1) is suggested to drive by constant current with typical value.

| Parameter | Symbol | Min. | Typ. | Max. | Unit | Remark |
|-------------------|--------|--------|------|--------|------|-----------|
| LED Current | I_L | -- | 20 | 22 | mA | Note 1 |
| Power Consumption | V_L | -- | 924 | 1108.8 | mW | |
| LED Life Time | L_L | 10,000 | -- | -- | Hr | Note 2, 3 |

Note 1: LED backlight is two parallel strings and one LED for each string is as below figure. Suggest to drive by 20mA for each LED string.

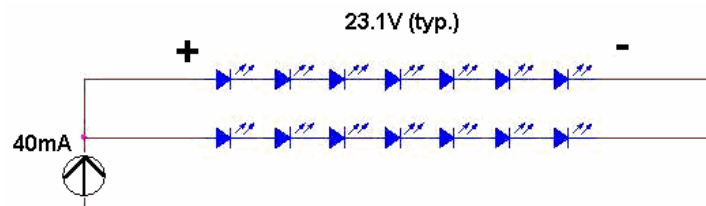

Note 2: Define "LED Lifetime": brightness is decreased to 50% of the initial value. LED Lifetime is restricted under normal condition, ambient temperature = 25°C and LED lightbar current = 20mA.

Note 3: If it uses larger LED lightbar voltage/ current more than 20mA, it maybe decreases the LED lifetime.

4. Electrical AC Characteristics

a. Signal AC Characteristics

| Parameter | Symbol | Min. | Typ. | Max. | Unit | Remark |
|--------------------|------------|------|------|------|------|-------------------|
| DCLK clock time | T_{clk} | 83 | - | - | ns | Parallel RGB Mode |
| Clock rising time | T_{rck} | 9 | - | - | ns | |
| Clock falling time | T_{fck} | 9 | - | - | ns | |
| HSD width | T_{hwh} | 1 | - | - | DCLK | |
| HSD period time | T_h | 55 | - | - | us | |
| HSD setup time | T_{hsu} | 12 | - | - | ns | |
| HSD hold time | T_{hhd} | 12 | - | - | ns | |
| VSD width | T_{vwh} | 1 | - | - | Th | |
| VSD setup time | T_{vsu} | 12 | - | - | ns | |
| VSD hold time | T_{vhhd} | 12 | - | - | ns | |
| DE setup time | t_{desu} | 12 | - | - | ns | |
| DE hold time | t_{dehd} | 12 | - | - | ns | |
| Data setup time | t_{dst} | 12 | - | - | ns | |
| Data hold time | t_{dhhd} | 12 | - | - | ns | |

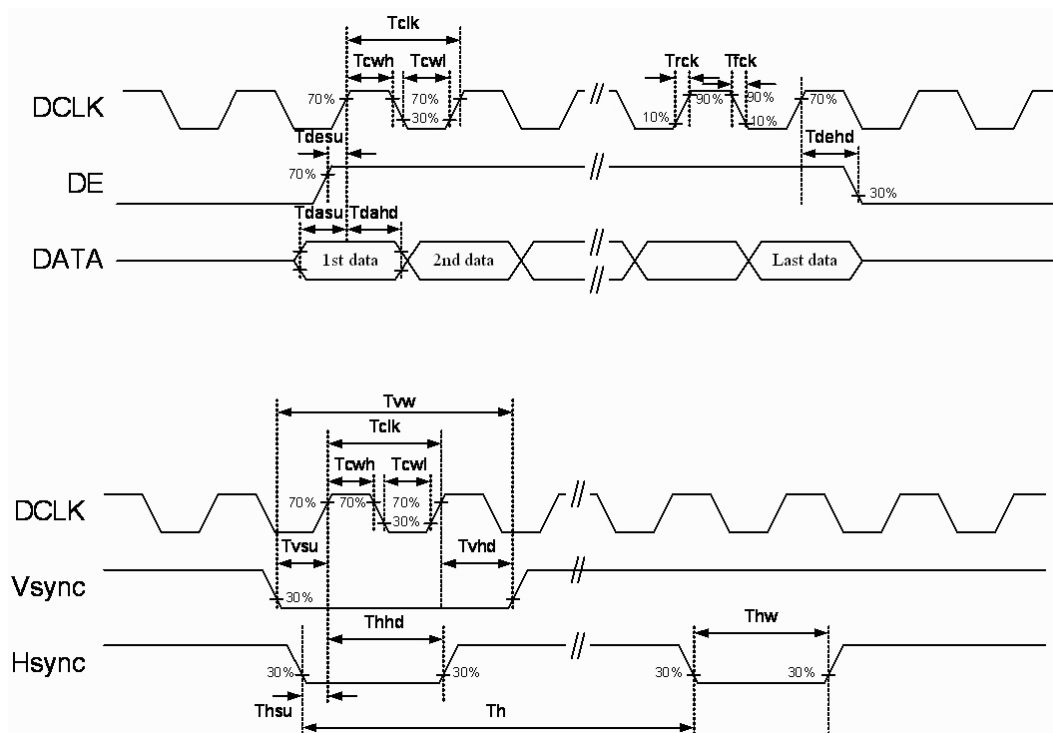

b. Input Timing

Vertical Timing of Input

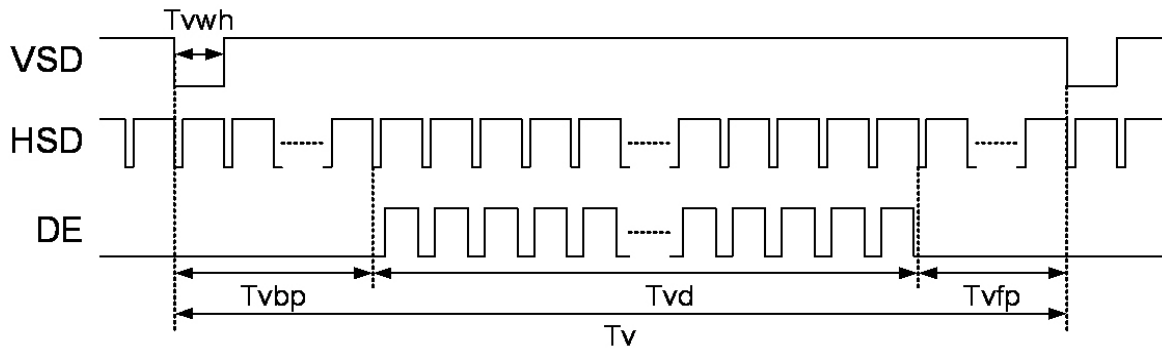

Horizontal Timing of Input

Parallel RGB Mode Data format

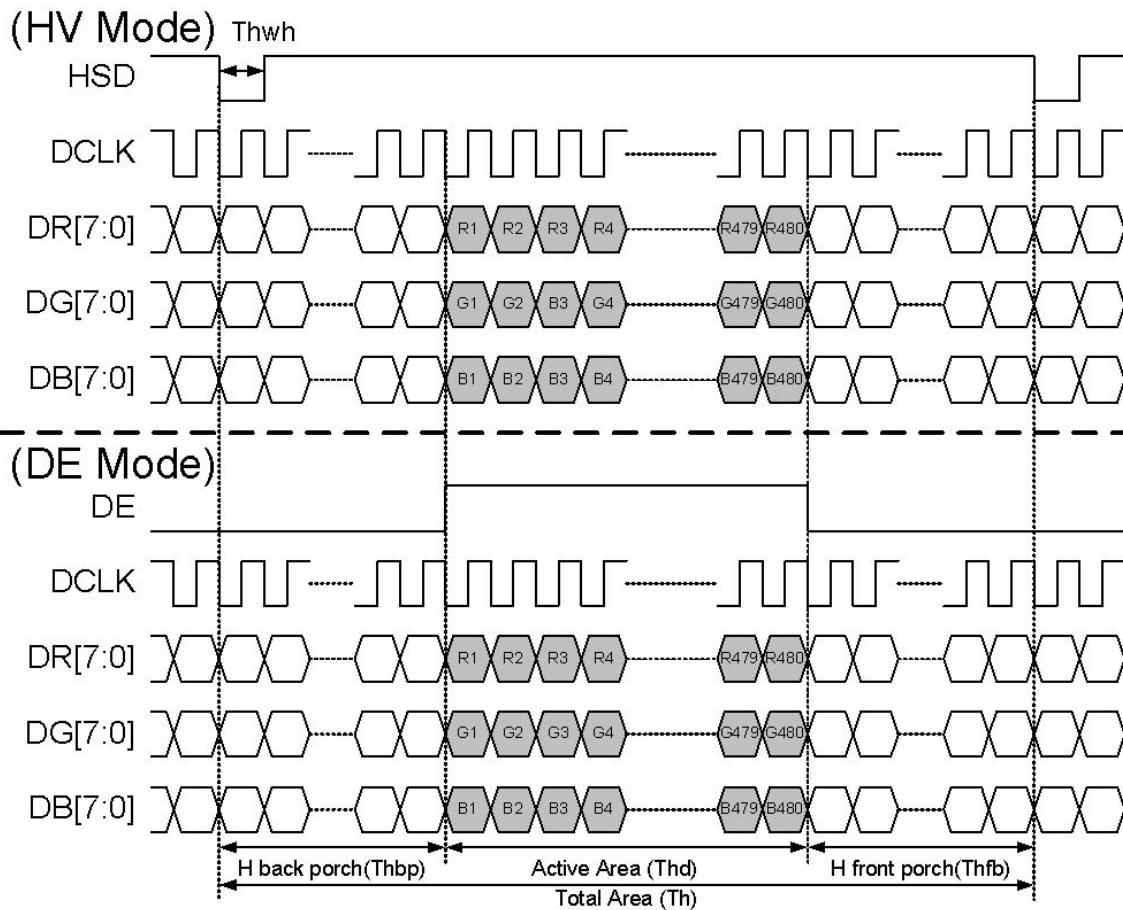

Parallel RGB input timing table

| PARAMETER | Symbol | Min | Typ | Max | Unit |
|-------------------|--------|-----|-----|-----|------|
| DCLK frequency | fclk | 5 | 9 | 12 | MHz |
| Horizontal Signal | | | | | |
| HSD period time | Th | 520 | 525 | 800 | DCLK |
| HSD display area | Thd | - | 480 | - | DCLK |
| HSD back porch | Thbp | 36 | 40 | 255 | DCLK |
| HSD front porch | Thfp | 4 | 5 | 65 | DCLK |
| Vertical Signal | | | | | |
| VSD period time | Tv | 277 | 288 | 400 | H |
| VSD display area | Tvd | - | 272 | - | H |
| VSD back porch | Tvbp | 3 | 8 | 31 | H |
| VSD front porch | Tvfp | 2 | 8 | 93 | H |

5. Serial Interface Characteristics

5.1 3-Wire Command Format

The 3-wire communication can be bi-directionally controlled by the “R/W” bit in the address field. The 3-wire engine acts as a “slave mode” at all times, and will not issue any command to the 3-wire bus itself.

Under read mode, the 3-wire engine will return the data during “Data phase”. The returned data should be latched at the rising edge of SCL by an external controller. Data in the “Hi-Z phase” will be ignored by the 3-wire engine during write operation, and should be ignored during read operation as well. During read operation, an external controller should float the SDA pin under “Hi-Z phase” and “Data phase”.

Each Read/Write operation should be exactly 16 bits. To prevent incorrect setting of the internal register, any write operation with more or less than 16 bits of data during a CSB Low period will be ignored by the 3-wire engine.

To prevent incorrect setting of the internal register, refer to the section “3-Wire Timing Diagram” for detailed timing.

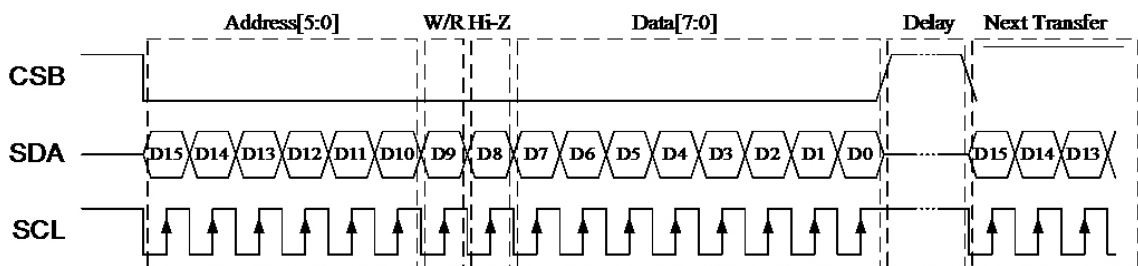

3-Wire Command Format:

| Bit | Description |
|---------|--|
| D15-D10 | Register Address [5:0]. |
| D9 | W/R control bit. "0" for Write; "1" for Read |
| D8 | Hi-Z bit during read mode. Any data within this bits will be ignored during write mode |
| D7-D0 | Data for the W/R operation to the address indicated by Address phase |

3-Wire Writer Format:

| MSB | | | | | | | | | | | | | | | LSB |
|------------------------|-----|-----|-----|-----|-----|----|----|-------------------------------------|----|----|----|----|----|----|-----|
| D15 | D14 | D13 | D12 | D11 | D10 | D9 | D8 | D7 | D6 | D5 | D4 | D3 | D2 | D1 | D0 |
| Register Address [5:0] | | | | | | 0 | X | DATA (Issue by external controller) | | | | | | | |

3-Wire Read Format:

| MSB | | | | | | | | | | | | | | | LSB |
|------------------------|-----|-----|-----|-----|-----|----|------|-------------------------------|----|----|----|----|----|----|-----|
| D15 | D14 | D13 | D12 | D11 | D10 | D9 | D8 | D7 | D6 | D5 | D4 | D3 | D2 | D1 | D0 |
| Register Address [5:0] | | | | | | 1 | Hi-Z | DATA (Issue by 3-Wire engine) | | | | | | | |

5.2 3-Wire Control Register List

| NO. | Address | | | | | | R/W | D8 | MSB | Initial value | | | | | | LSB | | |
|-----|---------|-----|-----|-----|-----|-----|-------|----|------------|----------------|--------|----------|-------|-----|------|-------|----|----|
| | D15 | D14 | D13 | D12 | D11 | D10 | | | | D9 | D7 | D6 | D5 | D4 | D3 | | D2 | D1 |
| R0 | 0 | 0 | 0 | 0 | 0 | 0 | RW(0) | X | HSDPOL | VSDPOL | CLKPOL | FPOL | NFSEL | 00 | | DITHB | | |
| R1 | 0 | 0 | 0 | 0 | 0 | 1 | RW(0) | X | 0 | 0 | 0 | 1 | STB | GRB | SHLR | UPDN | | |
| | | | | | | | | | 0 | 0 | | 1 | 1 | 1 | 1 | | | |
| R4 | 0 | 0 | 0 | 1 | 0 | 0 | RW(0) | X | DDL[7:0] | | | | | | | 0 | 0 | 0 |
| | | | | | | | | | 0 | 0 | 1 | 0 | 1 | 0 | 0 | | | |
| R5 | 0 | 0 | 0 | 1 | 0 | 1 | RW(0) | X | 0 | 0 | 0 | HDL[4:0] | | | | 0 | 0 | |
| | | | | | | | | | | | | 0 | 1 | 0 | 0 | | | 0 |
| R6 | 0 | 0 | 0 | 1 | 1 | 0 | RW(0) | X | 0 | VCOMH[6:0] | | | | | | 0 | 1 | |
| | | | | | | | | | | 1 | 0 | 0 | 1 | 1 | 0 | | | 1 |
| R7 | 0 | 0 | 0 | 1 | 1 | 1 | RW(0) | X | 0 | VCOML[6:0] | | | | | | 0 | 1 | |
| | | | | | | | | | | 0 | 0 | 0 | 1 | 1 | 0 | | | 1 |
| R8 | 0 | 0 | 1 | 0 | 0 | 0 | RW(0) | X | BRI[7:0] | | | | | | | 0 | 0 | |
| | | | | | | | | | 0 | 1 | 0 | 0 | 0 | 0 | 0 | | | 0 |
| R9 | 0 | 0 | 1 | 0 | 0 | 1 | RW(0) | X | CON_B[7:0] | | | | | | | 0 | 0 | |
| | | | | | | | | | 0 | 1 | 0 | 0 | 0 | 0 | 0 | | | 0 |
| R10 | 0 | 0 | 1 | 0 | 1 | 0 | RW(0) | X | 0 | SUB_BRI_R[6:0] | | | | | | 0 | 0 | |
| | | | | | | | | | | 1 | 0 | 0 | 0 | 0 | 0 | | | 0 |
| R11 | 0 | 0 | 1 | 0 | 1 | 1 | RW(0) | X | 0 | SUB_CON_R[6:0] | | | | | | 0 | 0 | |
| | | | | | | | | | | 1 | 0 | 0 | 0 | 0 | 0 | | | 0 |
| R12 | 0 | 0 | 1 | 1 | 0 | 0 | RW(0) | X | 0 | SUB_BRI_B[6:0] | | | | | | 0 | 0 | |
| | | | | | | | | | | 1 | 0 | 0 | 0 | 0 | 0 | | | 0 |
| R13 | 0 | 0 | 1 | 1 | 0 | 1 | RW(0) | X | 0 | SUB_CON_B[6:0] | | | | | | 0 | 0 | |
| | | | | | | | | | | 1 | 0 | 0 | 0 | 0 | 0 | | | 0 |

5.3 Suggested Serial Command Settings

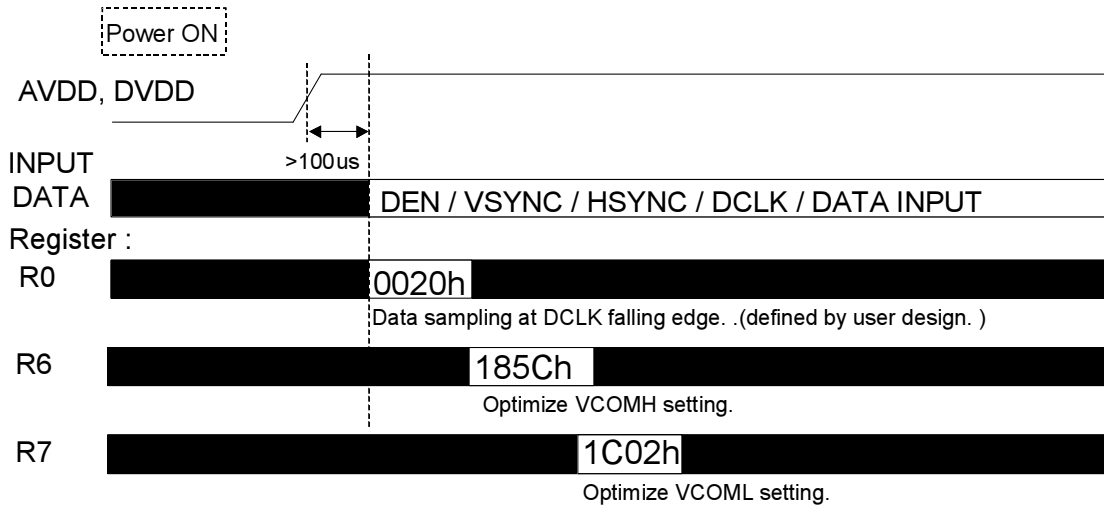

5.4 3-wire Registers Function Description

R0: Timing Controller Function Register

| Designation | Address | Description |
|-------------|---------|--|
| DITHB | R0[0] | Dithering control bit. DITHB="1", Dithering off, (7-bits resolution, truncation last 1-bits of the input data) DITHB="0", Dithering on, (Pseudo 8-bits resolution). (Default) |
| NFSEL | R0[3] | Narrow display mode selection bit. NFSEL="1": Narrow display format is enable. NFSEL="0": Normally display. (Default) |
| FPOL | R0[4] | VCOM polarity inverse control bit. When FPOL="1", VCOM inverse polarity. When FPOL="0", VCOM normal polarity. (Default) |
| CLKPOL | R0[5] | DCLK polarity control bit. CLKPOL="1": Data sampling at DCLK falling edge. CLKPOL="0": Data sampling at DCLK rising edge. (Default) |
| VSDPOL | R0[6] | VSD polarity control bit. VSDPOL="1": VSD positive polarity. VSDPOL="0": VSD negative polarity. (Default) |
| HSDPOL | R0[7] | HSD polarity control bit. VSDPOL="1": HSD positive polarity. VSDPOL="0": HSD negative polarity. (Default) |

Narrow display mode

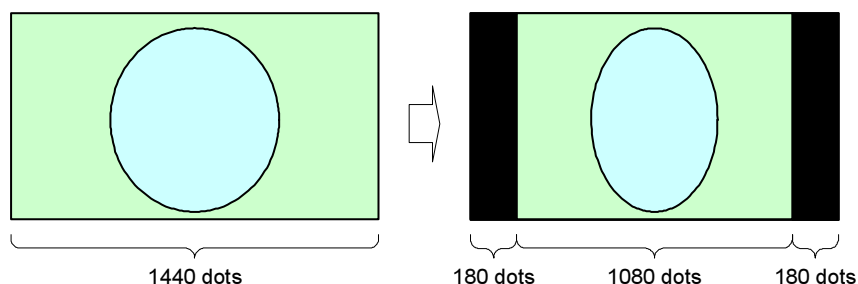

R1: Timing Controller Function Register

| Designation | Address | Description |
|-------------|---------|--|
| UPDN | R1[0] | Gate driver Up/Down scan control of gate driver. UPDN="1", Shift from up to down, First line=L1->L2-> ... ->L543->L544=Last line (Default) UPDN="0", Shift from down to up, First line=L544->L543-> ... ->L2->L1=Last line |
| SHLR | R1[1] | Right/Left sequence control of source driver. SHLR="1", Shift right: First data=S1->S2->S3 ... ->S720=Last data (Default) SHLR="0", Shift left: Last data=S1<-S2<-S3 ... <-S720=First data |
| GRB | R1[2] | Global reset bit. GRB="1", Normal operation. (Default) GRB="0", The controller is in reset state. |
| STB | R1[3] | Standby mode selection bit. STB="1", Normal operation. (Default) STB="0", Timing control, driver and DC-DC converter, are off, and all outputs are High-Z. |

NOTE: When SHLR="0", input RGB sequence does not need to sweep in serial mode.

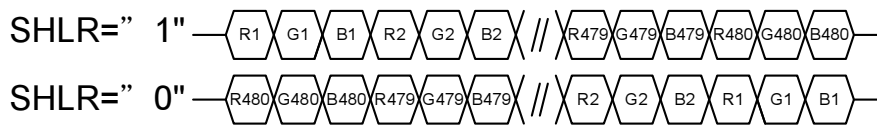

R4: Data Delay Setting

| Designation | Address | Description | | |
|-------------|---------|--|---------------------------------------|------|
| DDL[7:0] | R4[7:0] | Select the HSD signal to 1'st input data delay timing. | | |
| | | DDL[7:0] | DDL function | Unit |
| | | 24H | 36(Minimum setting for Parallel mode) | DCLK |
| | | 28H | 40(Default setting for Parallel mode) | |
| | | 6CH | 108(Minimum setting for Serial mode) | |
| | | 78H | 120(Default setting for Serial mode) | |
| | | FFH | 255 | |

Note: DDL function will be disabled under 8/24 bit DE mode.

R5: HSD Delay Setting

| Designation | Address | Description | | |
|-------------|---------|--|--------------------|------|
| HDL[4:0] | R5[4:0] | Select the Gate start pulse output delay timing. | | |
| | | HDL[4:0] | HDL function | Unit |
| | | 02H | 2(minimum setting) | HSD |
| | | 08H | 8(Default) | |
| 1FH | 31 | | | |

Note: HDL function will be disabled under 8/24 bit DE mode.

R6: VCOMH Level Control Register

| Designation | Address | Description | | | |
|-------------|---------|--|-------------|------|---|
| VCOMH[6:0] | R6[6:0] | VCOMH level adjustment. (20mV/LSB) | | | |
| | | VCOMH[6:0] | VCOMH level | Unit | V |
| | | 00H | 2.46 | | |
| | | 1BH | 3 | | |
| | | 4DH | 4 | | |
| 7FH | 5 | | | | |
| OTP_VCOMH | R6[7] | VCOMH data source selection register OTP_VCOMH="1", VCOMH is switched to the 3-wire register memory when the user wants to adjust the VCOMH level. OTP_VCOMH="0", VCOMH is read from OTP memory. (Default) | | | |

Note: VCOMH setting have to greater then AVDD.

R7: VCOML Control Register

| Designation | Address | Description | | | |
|-------------|---------|--|-------------|------|---|
| VCOML[6:0] | R7[6:0] | VCOML level adjustment. (20mV/LSB) | | | |
| | | VCOML[6:0] | VCOML level | Unit | V |
| | | 00H | -0.46 | | |
| | | 1BH | -1(Default) | | |
| | | 4DH | -2 | | |
| 7FH | -3 | | | | |
| OTP_VCOML | R7[7] | VCOML data source selection register OTP_VCOML="1", VCOML is switched to the 3-wire register memory when the user wants to adjust the VCOML level. OTP_VCOML="0", VCOML is read from OTP memory. (Default) | | | |

R8: Brightness Control Register

| Designation | Address | Description | | |
|-------------|---------|---|-------------------------|--|
| BRI[7:0] | R8[7:0] | Brightness level setting; gain changes 1 step/bit | | |
| | | BRI[7:0] | Brightness gain | |
| | | 00H | Dark (-64) | |
| | | 40H | Center (0) (Default) | |
| | | FFH | Bright (+191) | |

R9: Contrast Control Register

| Designation | Address | Description | |
|-------------|---------|---|---------------|
| CON[7:0] | R9[7:0] | Contrast level setting; gain changes (1/64)/bit | |
| | | CON[7:0] | Contrast gain |
| | | 00H | 0 |
| | | 40H | 1(Default) |
| | | FFH | 3.984 |

R10: SUB_Brightness_R Control Register

| Designation | Address | Description | |
|----------------|----------|--|----------------------|
| SUB_BRI_R[6:0] | R10[6:0] | Red sub-pixel brightness level setting; setting accuracy: 1 step/bit | |
| | | SUB_BRI_R[7:0] | R Brightness gain |
| | | 00H | Dark (-64) |
| | | 40H | Center (0) (Default) |
| | | 7FH | Bright (+63) |

R11: SUB_Contrast_R Control Register

| Designation | Address | Description | |
|----------------|----------|--|-----------------|
| SUB_CON_R[6:0] | R11[6:0] | Red sub-pixel contrast level setting; gain changes (1/256)/bit | |
| | | SUB_CON_R[7:0] | R Contrast gain |
| | | 00H | 0.75 |
| | | 40H | 1(Default) |
| | | 7FH | 1.246 |

R12: SUB_Brightness_B Control Register

| Designation | Address | Description | |
|----------------|----------|---|----------------------|
| SUB_BRI_B[6:0] | R12[6:0] | Blue sub-pixel brightness level setting; setting accuracy: 1 step/bit | |
| | | SUB_BRI_B[7:0] | B Brightness gain |
| | | 00H | Dark (-64) |
| | | 40H | Center (0) (Default) |
| | | 7FH | Bright (+63) |

R13: SUB_Contrast_B Control Register

| Designation | Address | Description | |
|----------------|----------|---|-----------------|
| SUB_CON_B[6:0] | R13[6:0] | Blue sub-pixel contrast level setting; gain changes (1/256)/bit | |
| | | SUB_CON_B[7:0] | B Contrast gain |
| | | 00H | 0.75 |
| | | 40H | 1(Default) |
| | | 7FH | 1.246 |

6. Power On/Off Characteristics

a. Recommended Power On Sequence

The LCD adopts high voltage driver IC, so it could be permanently damaged under a wrong power on/off sequence. The suggested LCD power sequence is below :

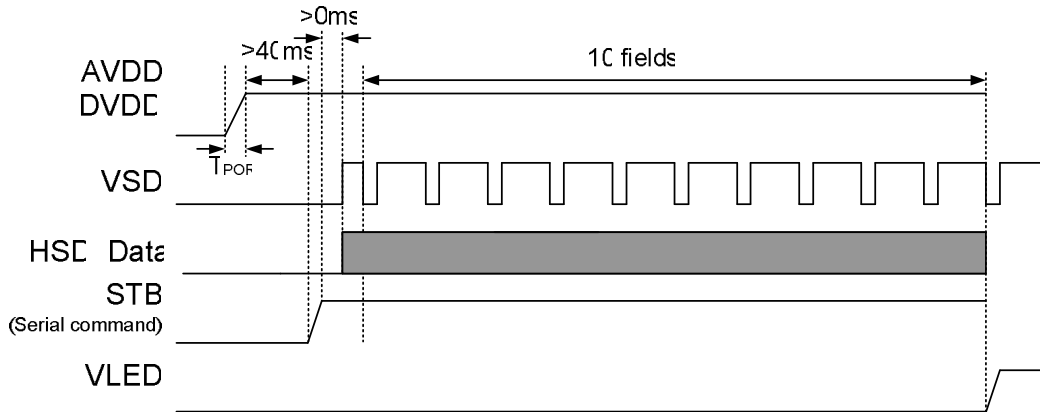

b. Recommended Power Off Sequence

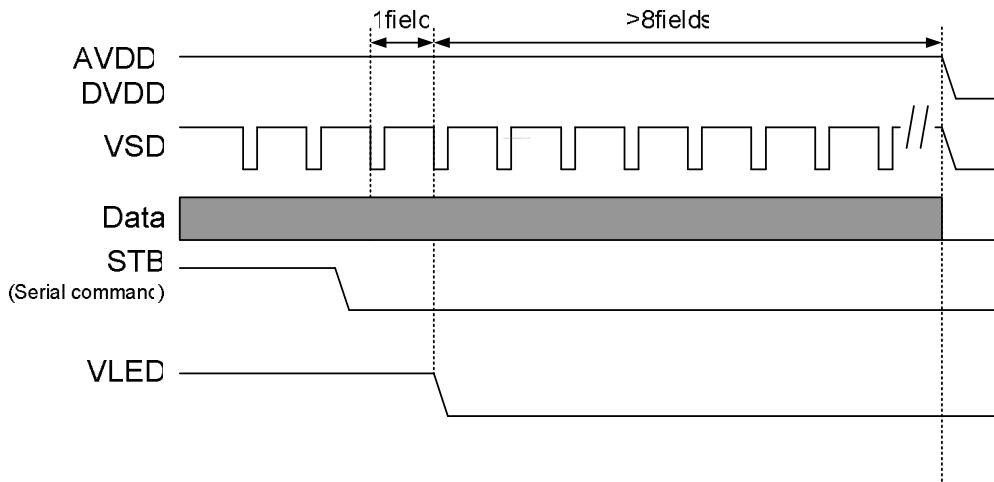

Notes: IC internal default setting STB="1", Normal operation.

D. Optical Specification

All optical specification is measured under typical condition (Note 1, 2)

| Item | Symbol | Condition | Min. | Typ. | Max. | Unit | Remark |
|--------------------|--------|----------------------|-------|-------|-------|----------|--------|
| Response Time Rise | Tr | $\theta=0^\circ$ | - | 7 | - | ms | Note 3 |
| | Tf | | - | 23 | - | ms | |
| Contrast ratio | CR | At optimized viewing | 400 | 500 | - | | Note 4 |
| Viewing Angle | Top | $CR \geq 10$ | - | 40 | - | deg. | Note 5 |
| | Bottom | | - | 60 | - | | |
| | Left | | - | 70 | - | | |
| | Right | | - | 70 | - | | |
| Brightness | Y_L | $\theta=0^\circ$ | 350 | 400 | - | cd/m^2 | Note 6 |
| Chromaticity | Rx | $\theta=0^\circ$ | 0.568 | 0.608 | 0.648 | | |
| | Ry | $\theta=0^\circ$ | 0.311 | 0.351 | 0.391 | | |
| | Gx | $\theta=0^\circ$ | 0.290 | 0.330 | 0.370 | | |
| | Gy | $\theta=0^\circ$ | 0.536 | 0.576 | 0.616 | | |
| | Bx | $\theta=0^\circ$ | 0.113 | 0.153 | 0.193 | | |
| | By | $\theta=0^\circ$ | 0.042 | 0.082 | 0.122 | | |
| | Wx | $\theta=0^\circ$ | 0.27 | 0.31 | 0.35 | | |
| | Wy | $\theta=0^\circ$ | 0.29 | 0.33 | 0.37 | | |

Note 1: Ambient temperature $\approx 25^\circ C$, and LED lightbar voltage $V_L = 12 V$. To be measured in the dark room.

Note 2: To be measured on the center area of panel with a viewing cone of 1° by Topcon luminance meter BM-5A, after 15 minutes operation.

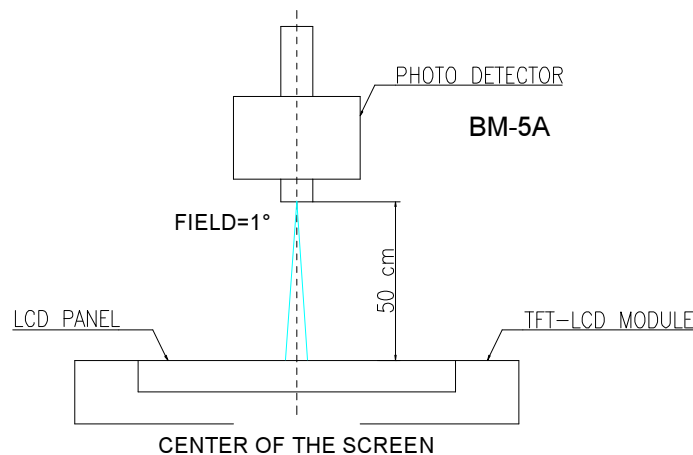

Note 3: Definition of response time:

The output signals of photo detector are measured when the input signals are changed from “black” to “white”(falling time) and from “white” to “black”(rising time), respectively.

The response time is defined as the time interval between the 10% and 90% of amplitudes. Refer to figure as below.

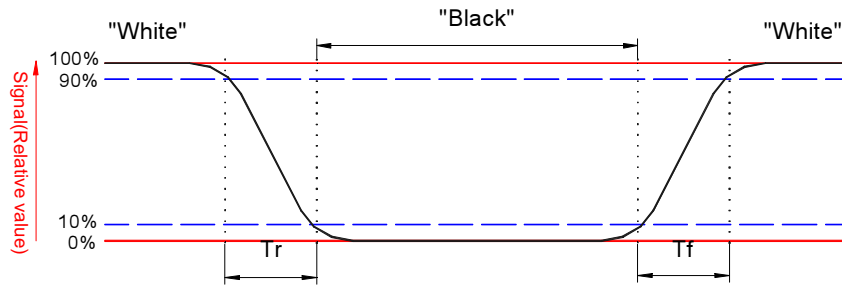

Note 4. Definition of contrast ratio:

Contrast ratio is calculated with the following formula.

$$\text{Contrast ratio (CR)} = \frac{\text{Photo detector output when LCD is at "White" status}}{\text{Photo detector output when LCD is at "Black" status}}$$

Note 5. Definition of viewing angle, θ , Refer to figure as below.

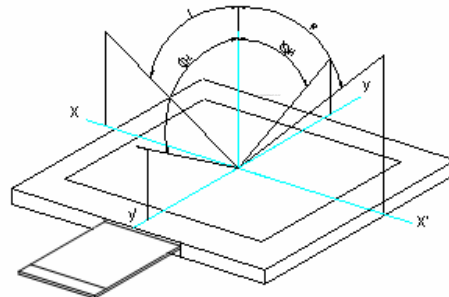

Note 6. Measured at the center area of the panel when all the input terminals of LCD panel are electrically opened.

Note 7: Luminance Uniformity of these 9 points is defined as below:

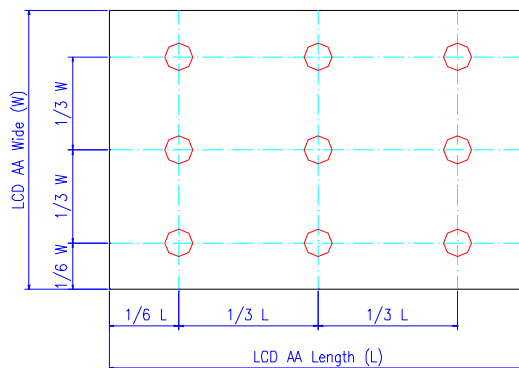

$$\text{Uniformity} = \frac{\text{minimum luminance in 9 points (1-9)}}{\text{maximum luminance in 9 points (1-9)}}$$

E. Touch Screen Panel Specifications

1. FPC Pin Assignment

| Pin No. | Symbol | I/O | Description |
|---------|--------|-----|----------------------------------|
| 1 | X1 | I/O | Touch panel right electrode (R) |
| 2 | Y2 | I/O | Touch panel bottom electrode (B) |
| 3 | X2 | I/O | Touch panel left electrode (L) |
| 4 | Y1 | I/O | Touch panel top electrode (U) |

2. Electrical Characteristics

| Item | | Min. | Typ | Max. | Unit | Remark |
|-----------------------|-----------|-------|-----|------|------|--------------|
| Rate DC Voltage | | -- | -- | 7 | V | |
| Resistance | X (Film) | 500 | -- | 1500 | Ω | At connector |
| | Y (Glass) | 100 | -- | 700 | | |
| Linearity | | -1.5% | | 1.5% | -- | Note 1 |
| Response Time | | | | 30 | ms | |
| Insulation Resistance | | 20 | | | MΩ | DC 25V |

Note 1: Measurement condition of Linearity: difference between actual voltage & theoretical voltage is an error at any points. Linearity is the value max. error voltage divided by voltage difference on active area.

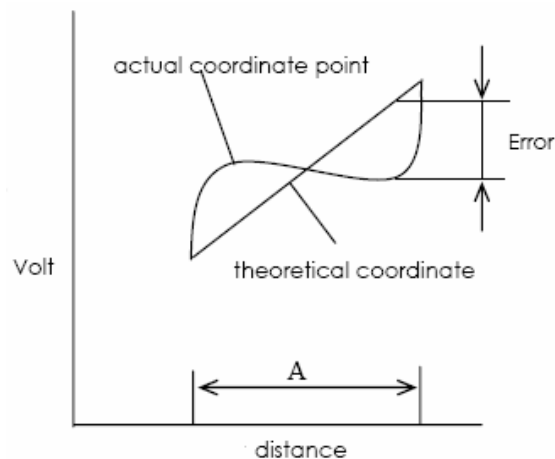

3. Mechanical Characteristics

| Item | Min. | Max. | Unit | Remark |
|---------------------------------|------|------|------|------------|
| Hardness of Surface | 3 | -- | H | JIS K-5600 |
| Operation Force (Pen or Finger) | -- | 80 | gf | Note 1, 2 |

Note 1: Within "active area", but not near the active area boundary and on the dot-spacer.

Note 2: Operation force measurement is under test condition as figure below.

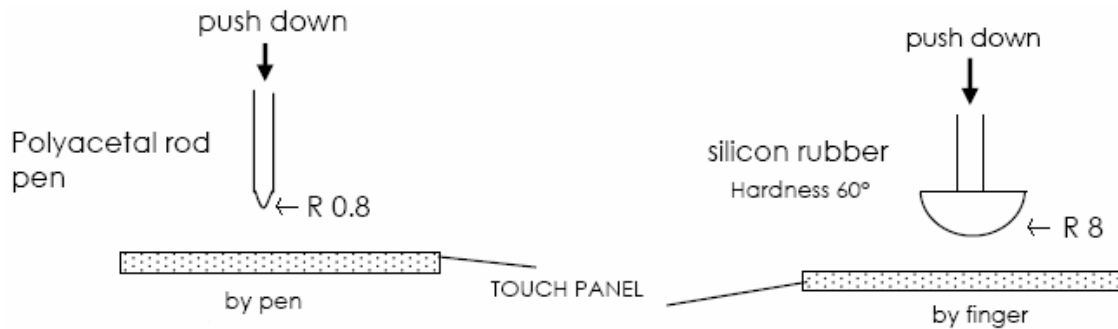

4. Life Test Condition

| Item | Min. | Max. | Unit | Remark |
|------------|--------|------|-------|-----------|
| Notes Life | 10^5 | -- | lines | Note 1, 2 |
| Input Life | 10^6 | -- | times | Note 1, 3 |

Note 1: Notes Life test condition (by pen): slide on central 2/3 of active area and use R 0.8mm polyacetal pen, input force : 250gf, frequency : 60mm/sec. Sliding from A to B complete 1 time. shown as figure.

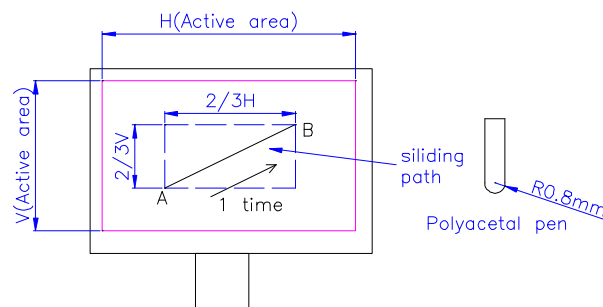

Note 2: Input Life test condition (by finger): test position on active area center and use R8.0mm silicon rubber (hardness 60°), test force: 250gf, frequency : 2times/sec. shown as figure.

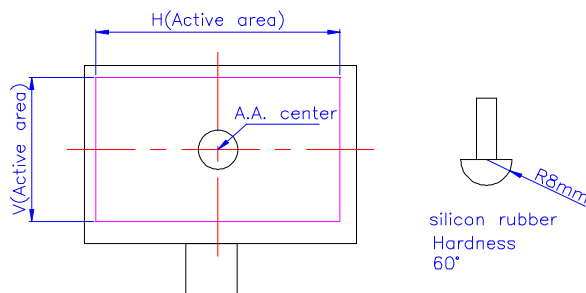

5. Attention

Please pay attention for below matters at mounting design of touch panel of LCD module.

- 1) Do not design casing opening area pressing the active area to prevent from miss input. Suggest casing opening area shown as mechanical drawing. Suggest the gap between casing and touch panel surface at least 0.5mm to avoid miss input.
- 2) Cushion area must not contact with active area. Suggest cushion area shown as mechanical drawing.
- 3) Use elastic or non-conductive material to enclosure touch panel.
- 4) Do not bond film of touch panel with casing.
- 5) The touch panel edge is conductive. Do not touch it with any conductive part after mounting.

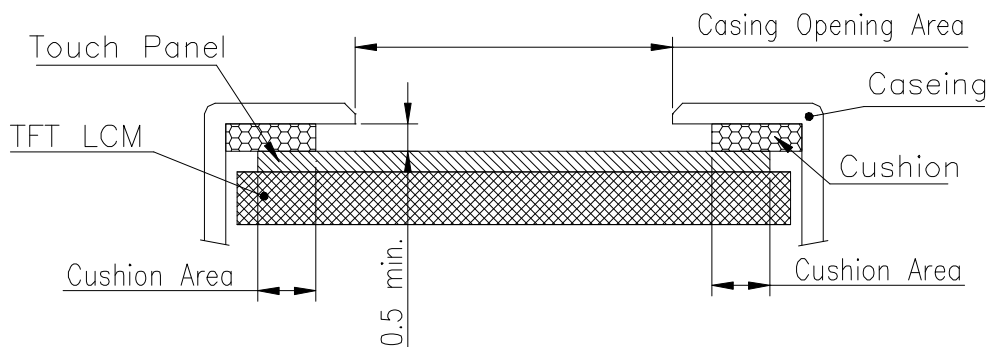

- 6) If user wants to cleaning touch panel by air gun, pressure 2kg/cm^2 below is suggested. Not to blow glass from FPC site to prevent FPC peeled off.
- 7) Do not put a heavy shock or stress on touch panel and film surface. Ex. Don't lift the panel by film face with vacuum.
- 8) Do not lift LCD module by FPC.
- 9) Please use dry cloth or soft cloth with neutral detergent (after wring dry) or one with ethanol at cleaning. Do not use any organic solvent, acid or alkali liquor.
- 10) Do not pile touch panel. Do not put heavy goods on touch panel.

F. Reliability Test Items

| No. | Test items | Conditions | Remark |
|-----|----------------------------------|---|---|
| 1 | High Temperature Storage | Ta= 80°C 240Hrs | |
| 2 | Low Temperature Storage | Ta= -30°C 240Hrs | |
| 3 | High Ttemperature Operation | Tp= 70°C 240Hrs | |
| 4 | Low Temperature Operation | Ta= -20°C 240Hrs | |
| 5 | High Temperature & High Humidity | Tp= 60°C, 90% RH 240Hrs | Operation |
| 6 | Heat Shock | -30 ~ 80°C, 30 cycles | Non-operation |
| 7 | Electrostatic Discharge | Contact = ± 4 kV, class B Air = ± 8 kV, class B | Note 4 |
| 8 | Image Sticking | 25°C, 4hrs | Note 5 |
| 9 | Vibration | Frequency range : 8~33.3Hz Stoke : 1.3mm Sweep : 2.9G ,33.3~400Hz 2 hours for each direction of X,Y,Z 4 hours for Y direction | Non-operation JIS C7021, A-10 condition A : 15 minutes |
| 10 | Mechanical Shock | 100G . 6ms, ±X,±Y,±Z 3 times for each direction | Non-operation JIS C7021, A-7 condition C |
| 11 | Vibration (With Carton) | Random vibration: 0.015G ² /Hz from 5~200Hz -6dB/Octave from 200~500Hz | IEC 68-34 |
| 12 | Drop (With Carton) | Height: 60cm 1 corner, 3 edges, 6 surfaces | |
| 13 | Pressure | 5kg, 5sec | Note 6 |

Note 1: Ta: Ambient Temperature. Tp: Panel Surface Temperature

Note 2: In the standard conditions, there is not display function NG issue occurred. All the cosmetic specification is judged before the reliability stress.

Note 3: All the cosmetic specification is judged before the reliability stress.

Note 4 : All test techniques follow IEC6100-4-2 standard.

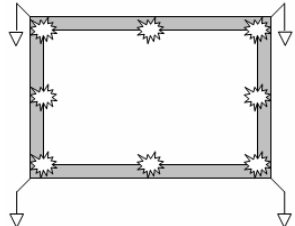
| Test Condition | | Note |
|----------------------|---|------|
| Pattern |  | |
| Procedure And Set-up | <p><u>Contact Discharge</u> : 330Ω, 150pF, 1sec, 8 point, 25times/point <u>Air Discharge</u> : 330Ω, 150pF, 1sec, 8 point, 25times/point</p>  | |
| Criteria | B – Some performance degradation allowed. No data lost. Self-recoverable hardware failure. | |
| Others | 1. Gun to Panel Distance 2. No SPI command, keep default register settings. | |

Note 5: Operate with chess board pattern as figure and lasting time and temperature as the conditions.
Then judge with 50% gray level, the mura is less than JND 2.8

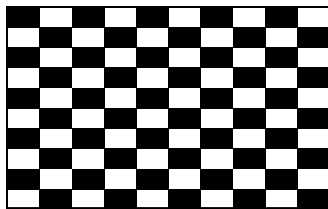

Note 6: The panel is tested as figure. The jig is $\phi 10\text{ mm}$ made by Cu with rubber and the loading speed is 3mm/min on position A~E. After the condition, no glass crack will be found and panel function check is OK.(no guarantee LC mura \ LC bubble)

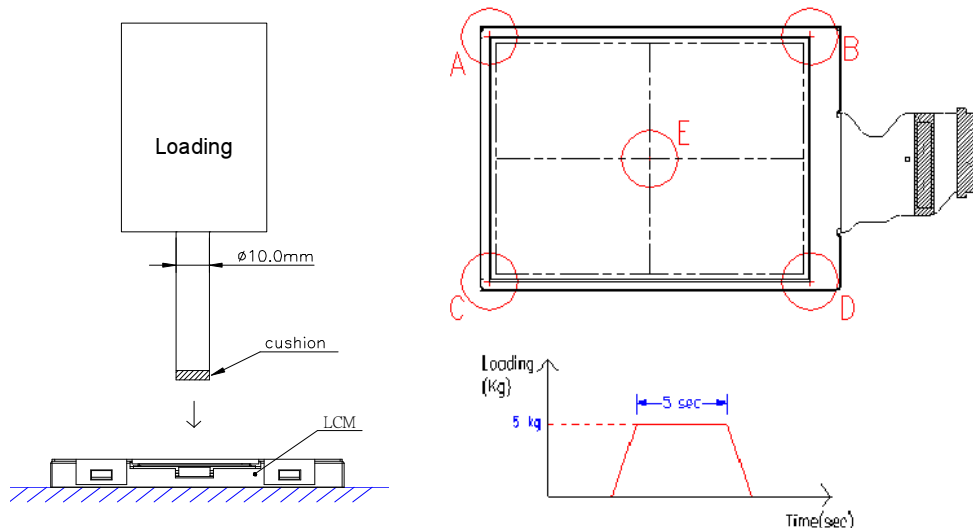

G. Packing and Marking

1. Packing Form

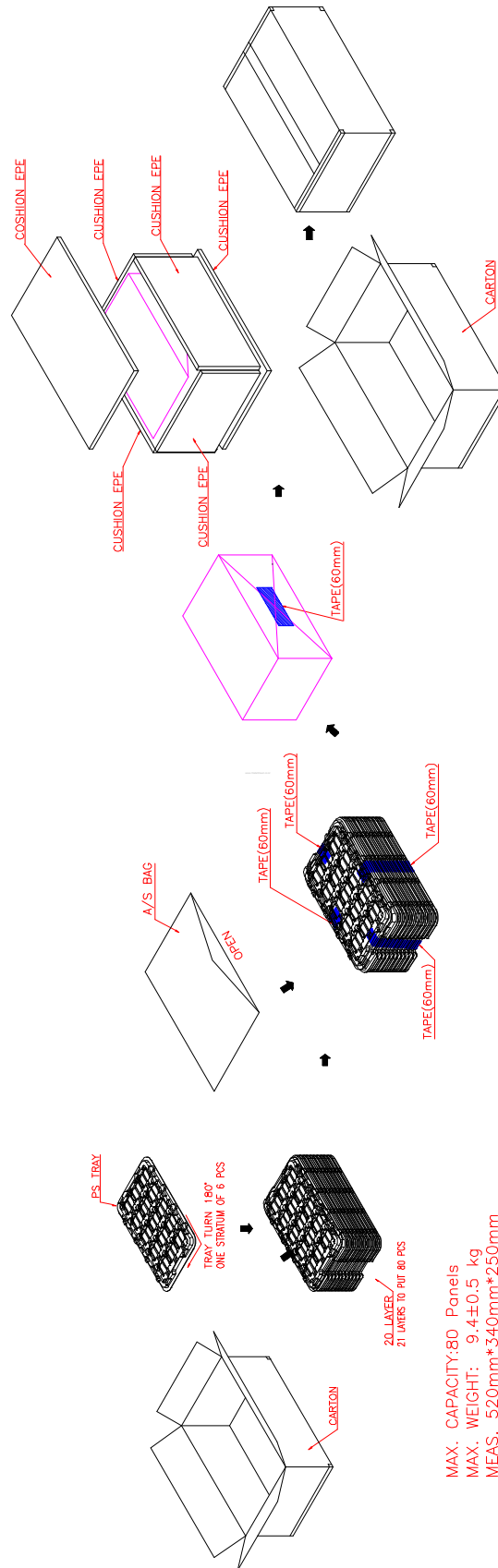

H. Precautions

1. Do not twist or bend the module and prevent the unsuitable external force for display module during assembly.
2. Adopt measures for good heat radiation. Be sure to use the module with in the specified temperature.
3. Avoid dust or oil mist during assembly.
4. Follow the correct power sequence while operating. Do not apply the invalid signal, otherwise, it will cause improper shut down and damage the module.
5. Less EMI: it will be more safety and less noise.
6. Please operate module in suitable temperature. The response time & brightness will drift by different temperature.
7. Avoid to display the fixed pattern (exclude the white pattern) in a long period, otherwise, it will cause image sticking.
8. Be sure to turn off the power when connecting or disconnecting the circuit.
9. Polarizer scratches easily, please handle it carefully.
10. Display surface never likes dirt or stains.
11. A dewdrop may lead to destruction. Please wipe off any moisture before using module.
12. Sudden temperature changes cause condensation, and it will cause polarizer damaged.
13. High temperature and humidity may degrade performance. Please do not expose the module to the direct sunlight and so on.
14. Acetic acid or chlorine compounds are not friends with TFT display module.
15. Static electricity will damage the module, please do not touch the module without any grounded device.
16. Do not disassemble and reassemble the module by self.
17. Be careful do not touch the rear side directly.
18. No strong vibration or shock. It will cause module broken.
19. Storage the modules in suitable environment with regular packing.
20. Be careful of injury from a broken display module.
21. Please avoid the pressure adding to the surface (front or rear side) of modules, because it will cause the display non-uniformity or other function issue.



I. Ordering Information:

| Part Number | Description |
|--------------|---------------------------|
| 97.05A10.200 | Touch panel vendor: SWENC |
| 97.05A10.201 | Touch panel vendor: EELY |