



# CUSTOMER APPROVAL SHEET

Company Name	
MODEL	A050FW03 V4
CUSTOMER APPROVED	Title : Name :

- APPROVAL FOR SPECIFICATIONS ONLY (Spec. Ver. 0.4 )
- APPROVAL FOR SPECIFICATIONS AND ES SAMPLE (Spec. Ver. 0.4 )
- APPROVAL FOR SPECIFICATIONS AND CS SAMPLE (Spec. Ver. 0.4 )
- CUSTOMER REMARK :

**AUO PM : Jesse Kao**

**P/N : 97.05A12.400**

**Comment :**



Doc. version :	0.4
Total pages :	32
Date :	2010/10/11

# **Product Specification**

## **5" COLOR TFT-LCD MODULE/PANEL**

**MODEL NAME: A050FW03 V4**

<  > Preliminary Specification

<  > Final Specification

Note: The content of this specification is subject to change.

© 2010 AU Optronics  
All Rights Reserved,  
Do Not Copy.

## Record of Revision

Version	Revise Date	Page	Content
0.0	2010.05.06		First Draft
0.1	2010.07.15	7	Update Current Consumption
		9	Update Signal AC Characteristics
		10	Add 3-wire AC Characteristics
		21	Update Power On Sequence
0.2	2010.08.25	7	Update Absolute Maximum Ratings
		7	Update Electrical DC Characteristics
		9	Update Electrical AC Characteristics
		22	Update Optical Specification ( add Uniformity )
0.3	2010.08.27	3	Update General Information
		7	Update Absolute Maximum Ratings
		7	Update Electrical DC Characteristics
		9~11	Update Electrical AC Characteristics
0.4	2010.10.11	21	Power ON/OFF sequence
		22	Add uniformity spec.
		26	Modify TP attention content

## Contents

<b>A.</b>	<b>General Information</b> .....	<b>3</b>
<b>B.</b>	<b>Outline Dimension</b> .....	<b>4</b>
	1. TFT-LCD Module – Front and Rear View.....	4
<b>C.</b>	<b>Electrical Specifications</b> .....	<b>5</b>
	1. TFT LCD Panel Pin Assignment .....	5
	2. Absolute Maximum Ratings.....	7
	3. Electrical DC Characteristics.....	7
	4. Electrical AC Characteristics .....	9
	5. Serial Interface Characteristics .....	13
	6. Power On/Off Characteristics.....	21
<b>D.</b>	<b>Optical Specification</b> .....	<b>22</b>
<b>E.</b>	<b>Touch Screen Panel Specifications</b> .....	<b>24</b>
	1. FPC Pin Assignment .....	24
	2. Electrical Characteristics .....	24
	3. Mechanical Characteristics .....	25
	4. Life Test Condition .....	25
	5. Attention.....	26
<b>F.</b>	<b>Reliability Test Items</b> .....	<b>27</b>
<b>G.</b>	<b>Packing and Marking</b> .....	<b>30</b>
	1. Packing Form .....	30
<b>H.</b>	<b>Application Note</b> .....	<b>31</b>
	1. Application Circuit.....	31
<b>I.</b>	<b>Precautions</b> .....	<b>32</b>

## A. General Information

This product is for portable PND and digital photo frame application.

NO.	Item	Unit	Specification	Remark
1	Screen Size	inch	5.0(Diagonal)	
2	Display Resolution	dot	480RGB (H) X 272 (V)	
3	Overall Dimension	mm	120.7(H) X 75.8(V) X 4.25(T)	Note 1
4	Active Area	mm	110.88 (H) X 62.832 (V)	
5	Pixel Pitch	mm	0.231 (H) X 0.231 (V)	
6	Color Configuration	--	R. G. B. Stripe	Note 2
7	Color Depth	--	16.7M Colors	Note 3
8	NTSC Ratio (Cell)	%	50	
9	Display Mode	--	Normally White	
10	Panel surface Treatment	--	Anti-Glare, 3H	
11	Weight	g	75	
12	Power Consumption	mW	834	Note 4
13	Viewing direction		6 o'clock (gray inversion)	

Note 1: Not include backlight cable and FPC. Refer next page to get further information.

Note 2: Below figure shows dot stripe arrangement.

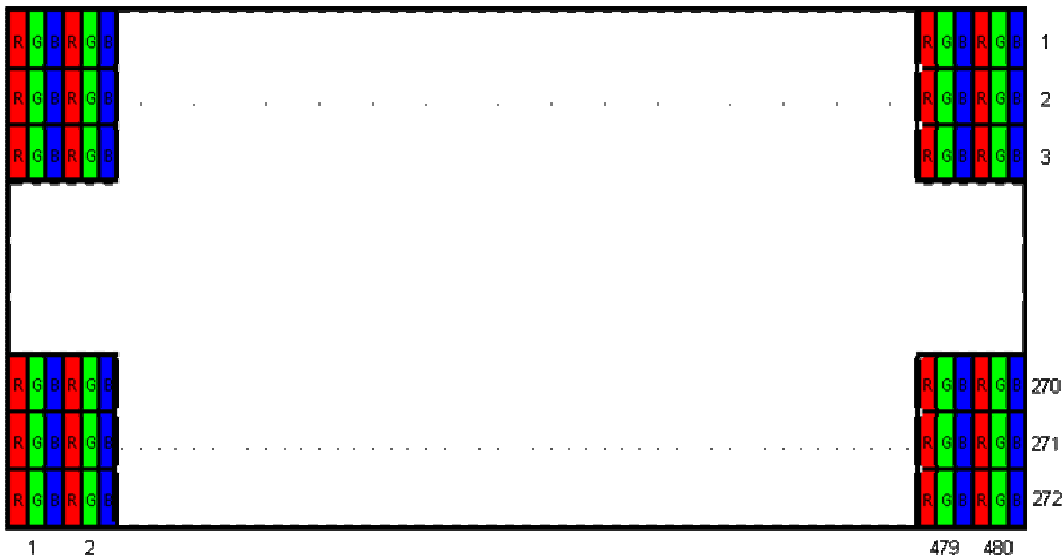

Note 3: The full color display depends on 24-bit data signal.

Note 4: Please refer to Electrical Characteristics chapter.

## B. Outline Dimension

### 1. TFT-LCD Module – Front and Rear View

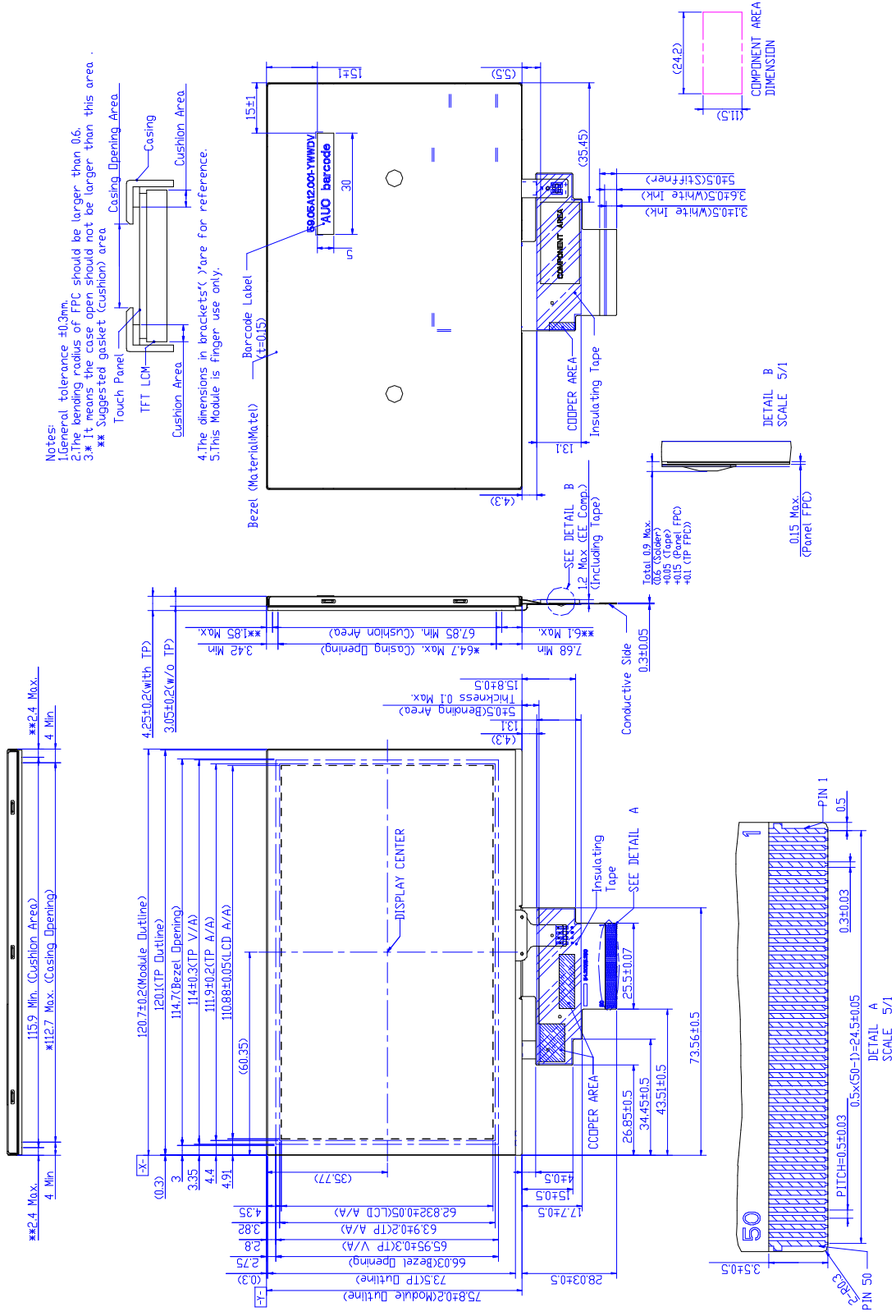

### C. Electrical Specifications

#### 1. TFT LCD Panel Pin Assignment

Recommended connector:

No.	Pin Name	I/O	Description	Remarks
1	GND	G	GND	
2	VDD	PI	Power supply for analog circuit	
3	VDDIO	PI	Power supply for digital interface	
4	GND	G	GND	
5	TP_R	I/O	X Right	
6	TP_B	I/O	Y Bottom	
7	TP_L	I/O	X Left	
8	TP_U	I/O	Y Up	
9	VSYNC	I	Vertical synchronizing signal	
10	HSYNC	I	Horizontal synchronizing signal	
11	DE	I	Data enable	
12	GND	G	GND	
13	DCLK	I	Pixel clock	
14	GND	G	GND	
15	R3	I	Red Data Signal (LSB)	
16	R4	I	Red Data Signal	
17	GND	G	GND	
18	R5	I	Red Data Signal	
19	R6	I	Red Data Signal	
20	GND	G	GND	
21	R7	I	Red Data Signal ( MSB )	
22	G2	I	Green Data Signal (LSB)	
23	GND	G	GND	
24	G3	I	Green Data Signal	
25	G4	I	Green Data Signal	
26	GND	G	GND	
27	G5	I	Green Data Signal	
28	G6	I	Green Data Signal	
29	GND	G	GND	
30	G7	I	Green Data Signal(MSB)	
31	B3	I	Blue Data Signal (LSB)	
32	GND	G	GND	
33	B4	I	Blue Data Signal	
34	B5	I	Blue Data Signal	
35	GND	G	GND	

36	B6	I	Blue Data Signal	
37	B7	I	Blue Data Signal	
38	GND	G	GND	
39	DISP	I	Display on/off signal	
40	NC	-	No connect	
41	GND	G	GND	
42	GND	G	GND	
43	SCL	I	Clock input in serial mode	
44	GND	G	GND	
45	SDA	I	Data input pin in serial mode	
46	CS	I	Chip select pin of serial interface	
47	LED-	PI	LED backlight cathode	
48	NC	-	No connect	
49	LED+	PI	LED backlight anode	
50	GND	G	GND	

I: Digital signal input, O: Digital signal output, G: GND, PI: Power input, C: Capacitor



## 2. Absolute Maximum Ratings

Items	Symbol	Values		Unit	Condition
		Min.	Max.		
Power Supply Voltage	VDD	-0.3	6	V	
Interface Supply Voltage	VDDIO	-0.3	6	V	
LED Reverse Voltage	$V_r$		5	V	One LED
LED Forward Voltage	$V_f$	3		V	One LED
LED Forward Current	$I_f$	--	25	mA	One LED
Operation Temperature	$T_{op}$	-20	70	°C	
Storage Temperature	$T_{st}$	-30	80	°C	

Note 1: Functional operation should be restricted under ambient temperature (25°C).

Note2: Maximum ratings are those values beyond which damages to the device may occur. Functional operation should be restricted to the limits in the Electrical Characteristics chapter.

## 3. Electrical DC Characteristics

### a. Typical Operation Condition (GND = 0V)

Item		Symbol	Min.	Typ.	Max.	Unit	Remark
Power Voltage		VDDIO	1.65	--	VDD	V	Digital Power Supply
		VDD	3.0	3.3	3.6	V	Analog Power Supply
Input Signal Voltage	H Level	$V_{IH}$	$0.7 \times V_{DDIO}$	--	VDDIO	V	
	L Level	$V_{IL}$	GND	--	$0.3 \times V_{DDIO}$	V	

### b. Current Consumption (GND=0V)

Parameter	Symbol	Condition	Min.	Typ.	Max.	Unit	Remark
Input Current for VDD	$I_{VDD}$	VDD=3.3V	-	21	28	mA	Note 1, 2
	$I_{VDD}$ (STANDBY)	VDD=3.3V	-	12	15	uA	Note 3
Input Current for VDDIO	$I_{VDDIO}$	VDDIO=3.3V	-	20	40	uA	Note 1, 2
	$I_{VDDIO}$ (STANDBY)	VDDIO=3.3V	-	35	40	uA	Note 3

Note 1: Test Condition is under typical Electrical DC and AC characteristics.

Note 2: Test pattern is the following picture.

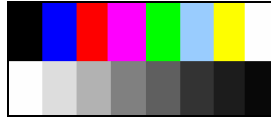

Note 3: In standby mode, all digital signals are stopped. Ex. DCLK, DE ..etc.

### c. Backlight Driving Conditions

The backlight (LED module, Note 1) is suggested to drive by constant current with typical value.

Parameter	Symbol	Min.	Typ.	Max.	Unit	Remark
LED Current	$I_L$	--	20	22	mA	Note 1
Power Consumption	$P_L$	--	768	910.8	mW	
LED Life Time	$L_L$	10,000	--	--	Hr	Note 2, 3

Note 1: LED backlight is two parallel strings and one LED for each string is as below figure. Suggest to drive by 20mA for each LED string.

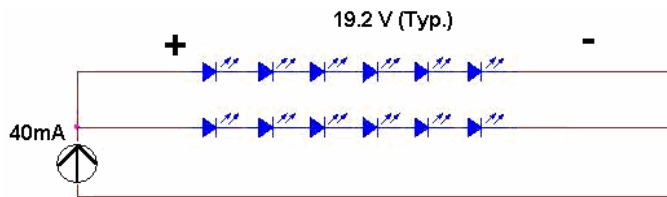

Note 2: Define "LED Lifetime": brightness is decreased to 50% of the initial value. LED Lifetime is restricted under normal condition, ambient temperature = 25°C and LED lightbar current = 20mA.

Note 3: If it uses larger LED lightbar voltage/ current more than 20mA, it maybe decreases the LED lifetime.

## 4. Electrical AC Characteristics

### a. Signal AC Characteristics

Parameter	Symbol	Min.	Typ.	Max.	Unit	Remark
DCLK duty cycle	$D_{cw}$	40	50	60	%	$t_{cw} / t_{DCLK} \times 100\%$
CLK pulse duty	$t_{cw}$	40	--	--	ns	
Data Setup Time	$t_{dst}$	6	--	--	ns	
Data Hold Time	$t_{dhd}$	6	--	--	ns	
DE Setup Time	$t_{dest}$	6	--	--	ns	
DE Hold Time	$t_{dehd}$	6	--	--	ns	
Vsync Setup Time	$t_{vst}$	6	--	--	ns	
Vsync Hold Time	$t_{vhd}$	6	--	--	ns	
Hsync Setup Time	$t_{hst}$	6	--	--	ns	
Hsync Hold Time	$t_{hhd}$	6	--	--	ns	

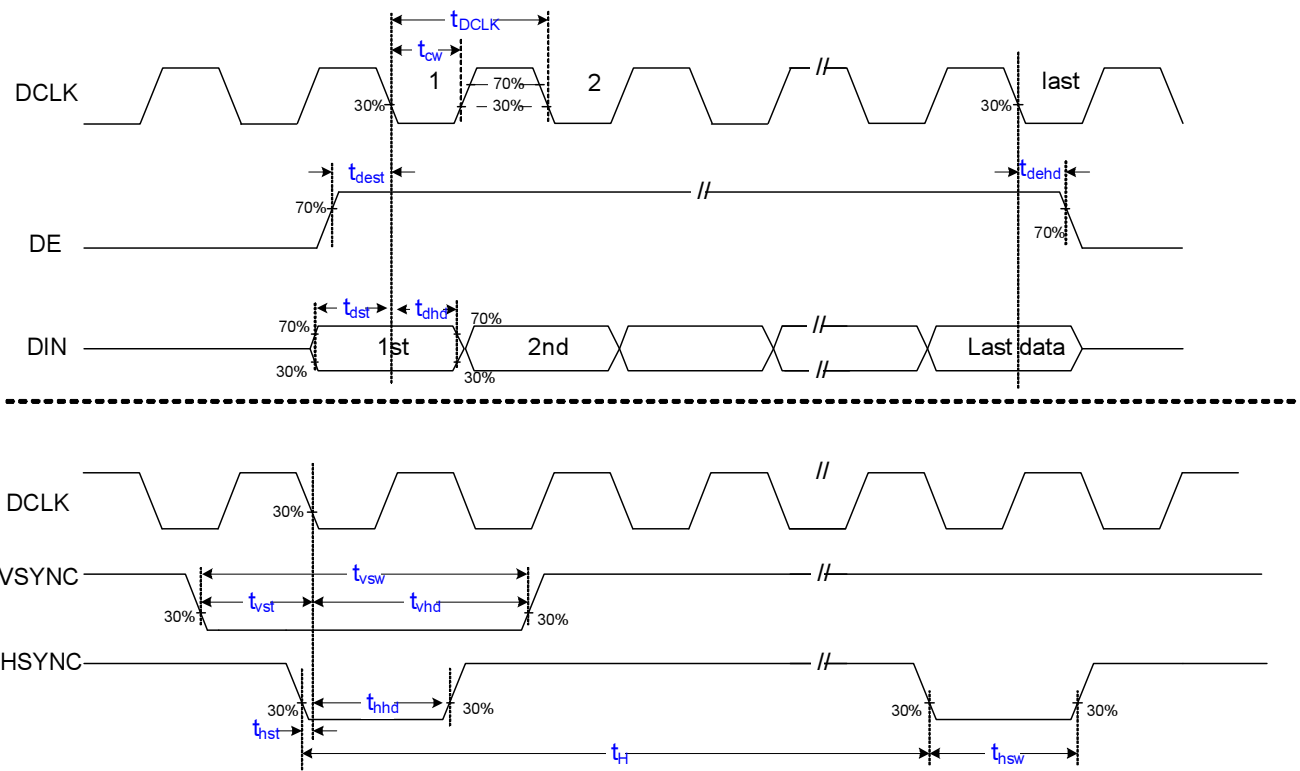

**b. Serial port interface AC characteristics**

(VDDSI=1.65 ~ VDD)

3-wire serial communication AC timing					
Parameter	Symbol	Min	Typ	Max	Unit
CSB input setup time	$t_{s0}$	50	-	-	ns
CSB input hold time	$t_{H0}$	50	-	-	ns
CSB pulse high width	$t_{W2}$	400	-	-	us
SDA input setup time	$t_{s1}$	50	-	-	ns
SDA input hold time	$t_{H1}$	50	-	-	ns
SCL pulse low width	$t_{W1L}$	50	-	-	ns
SCL pulse high width	$t_{W1H}$	50	-	-	ns

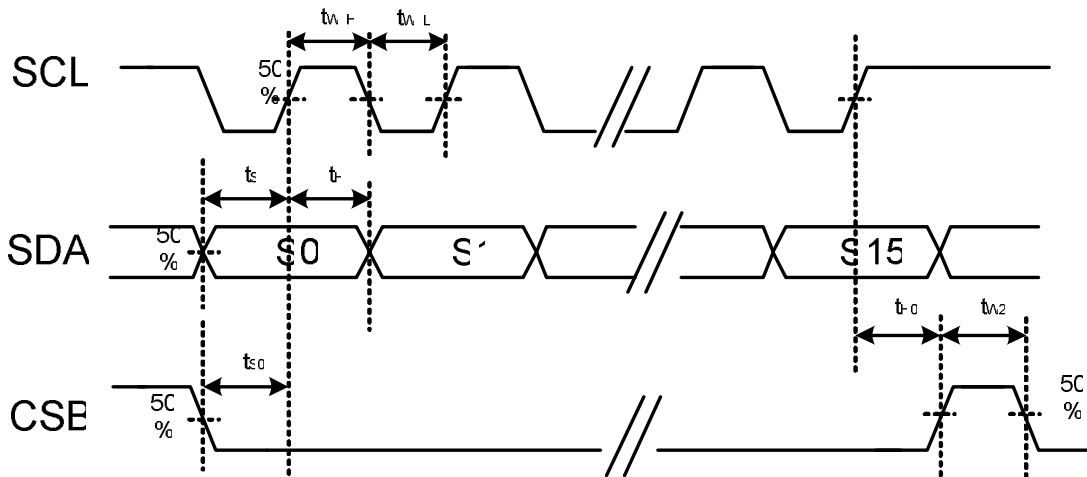
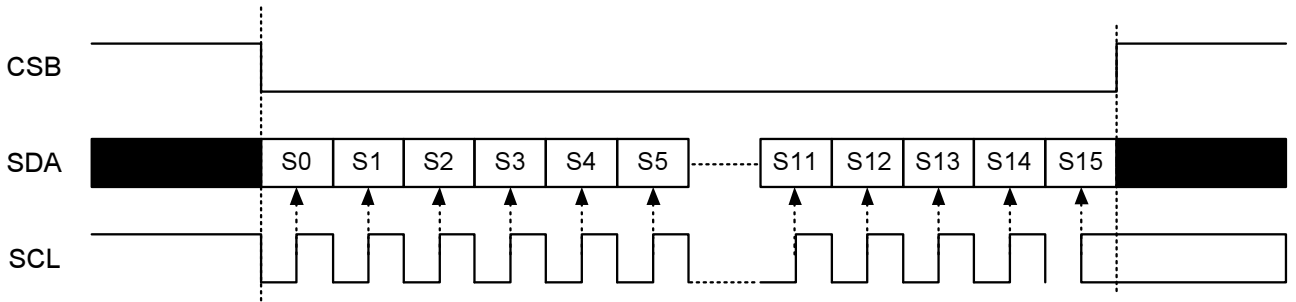

**c. Input Timing**

Parameter		Symbol	Min.	Typ.	Max.	Unit.	Remark
DCLK	Frequency	$1/t_{DCLK}$	5	9	12	MHz	
Frame Rate	Frequency		55	60	70	Hz	
1 Frame Scanning Time	Cycle	$t_v$	282	288	400	$t_H$	
	Display Period	$t_{vd}$	272			$t_H$	
	Blanking	$t_{vbl}$	10	16	128	$t_H$	
1 Line Scanning Time	Cycle	$t_H$	495	525	800	$t_{DCLK}$	
	Display Period	$t_{hd}$	480			$t_{DCLK}$	
	Blanking	$t_{hbl}$	15	45	320	$t_{DCLK}$	

**Vertical Timing of Input(DE mode)**

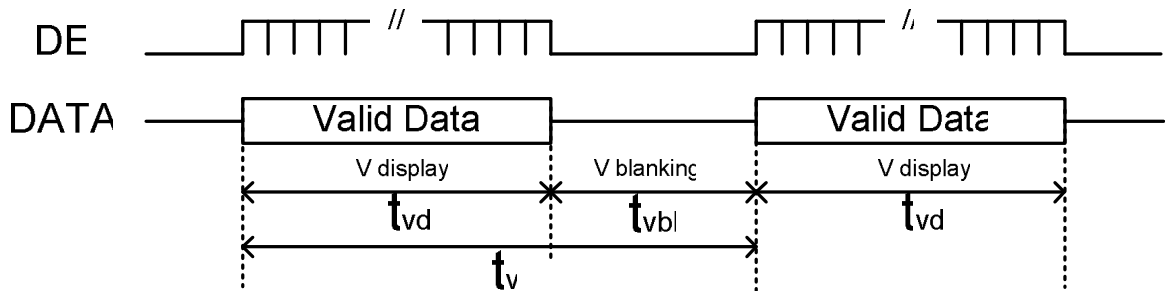

**Horizontal Timing of Input (DE mode)**

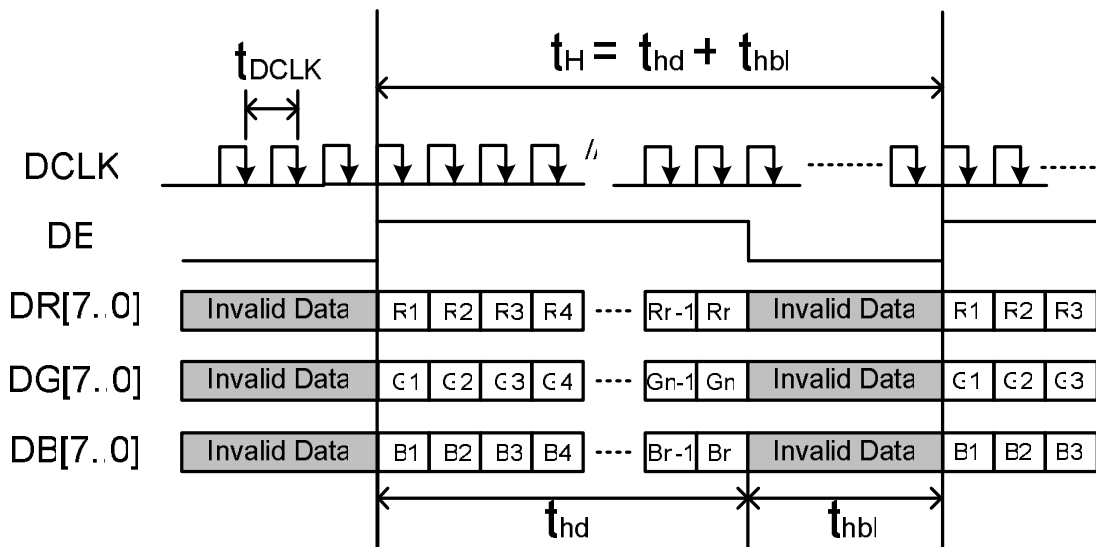

**Note: The DE mode is being recommended as the first option.**

Parameter		Symbol	Min.	Typ.	Max.	Unit.	Remark
DCLK	Frequency	$1/t_{DCLK}$	5	9	12	MHz	
Frame Rate	Frequency		55	60	70	Hz	
VSYNC	Period	$t_v$	277	288	400	$t_H$	
	Display period	$t_{vd}$	272			$t_H$	
	Back porch	$t_{vbp}$	1	8	31	$t_H$	
	Front porch	$t_{vfp}$	4	8	97	$t_H$	
	Pulse width	$t_{vsw}$	$1 t_{DCLK}$	$1 t_{DCLK}$	$6 t_H$		
HSYNC	Period	$t_H$	495	525	800	$t_{DCLK}$	
	Display period	$t_{hd}$	480			$t_{DCLK}$	
	Back porch	$t_{hbp}$	10	40	255	$t_{DCLK}$	
	Front porch	$t_{hfp}$	5	5	65	$t_{DCLK}$	
	Pulse width	$t_{hsw}$	1	1	$t_{hbp} - 1$	$t_{DCLK}$	

### Vertical Timing of Input(Sync mode)

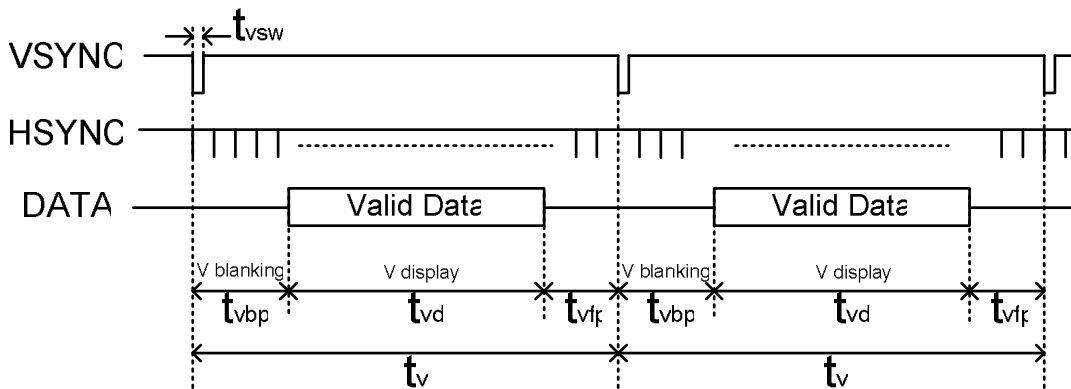

### Horizontal Timing of Input (Sync mode)

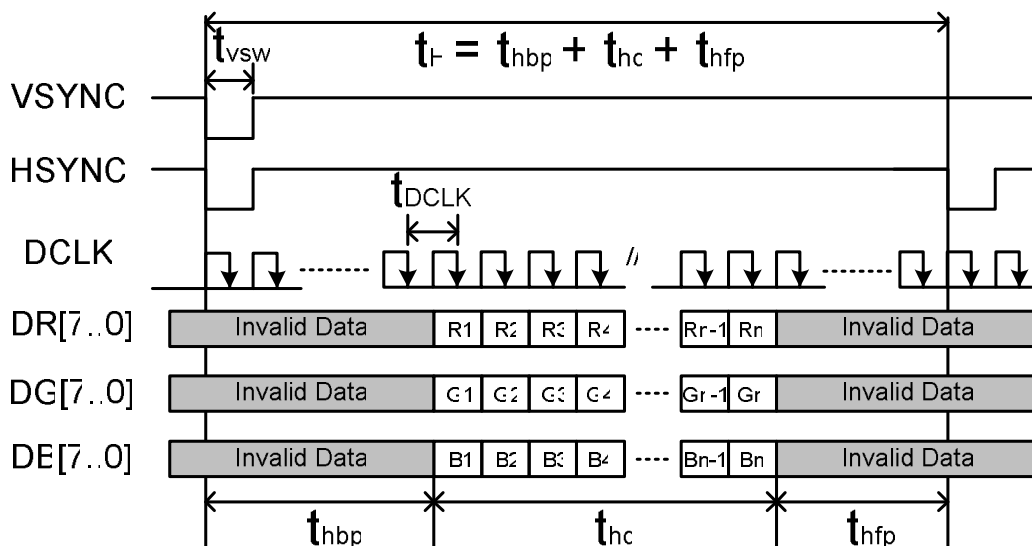

## 5. Serial Interface Characteristics

### 5.1 3-Wire Command Format

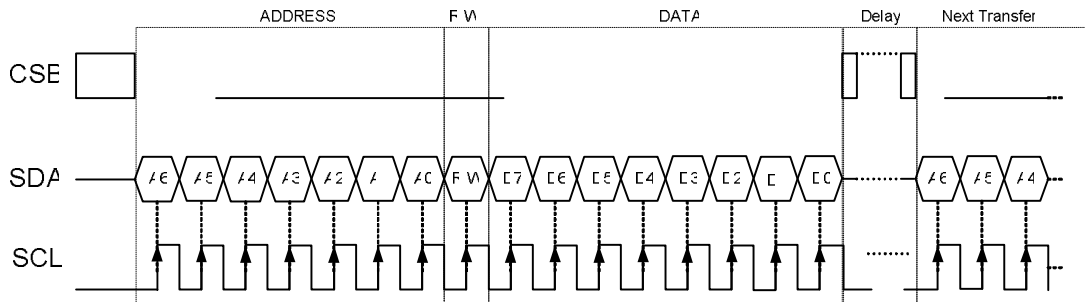

1. Each serial command consists of 16 bits of data which is loaded one bit a time at the rising edge of serial clock SCL.
2. Command loading operation starts from the falling edge of CSB and is completed at the next rising edge of CSB.
3. The serial control block is operational after power on reset, but commands are established by the VSYNC signal. If command is transferred multiple times for the same register, the last command before the VSYNC signal is valid.
4. If less than 16 bits of SCL are input while CSB is low, the transferred data is ignored.(Note1)
5. If 16 bits or more of SCL are input while CSB is low, the previous 16 bits of transferred data after the falling edge of CSB pulse are valid data.(Note2)
6. Serial block operates with the SCL clock.
7. Serial data can be accepted in the standby (power save) mode.

Note1 (data < 16bits):

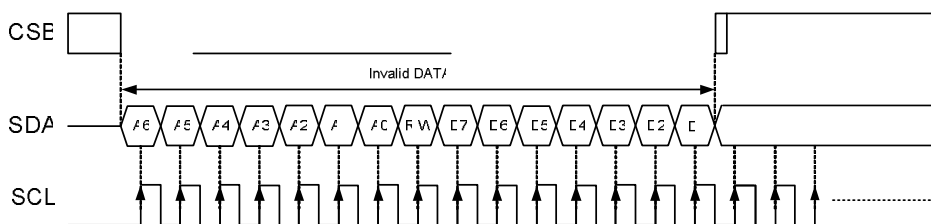

Note2 (data > 16bits):

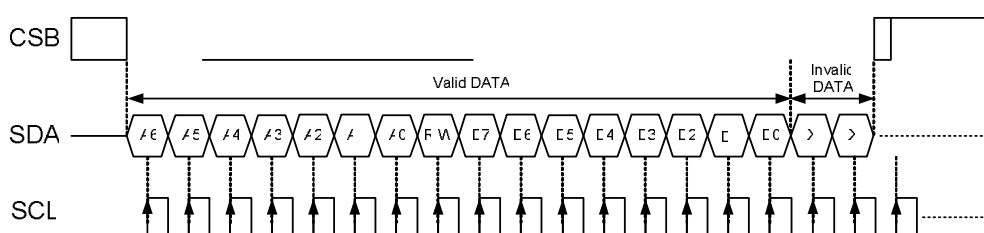

**3-Wire Command Format:**

MSB								LSB							
A6	A5	A4	A3	A2	A1	A0	R/W	D7	D6	D5	D4	D3	D2	D1	D0
Register Address [6:0]							Read or Write	DATA (Issue by external controller)							

**3-Wire Writer Format:**

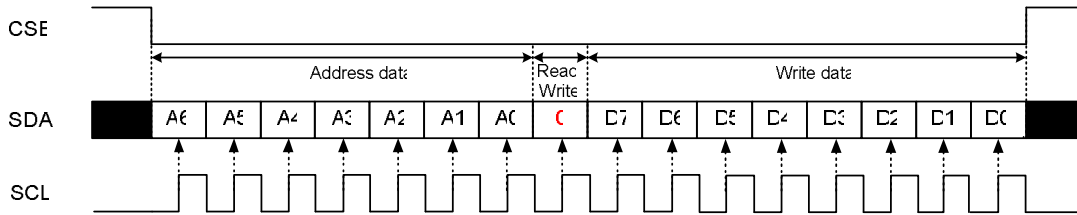

**3-Wire Read Format:**

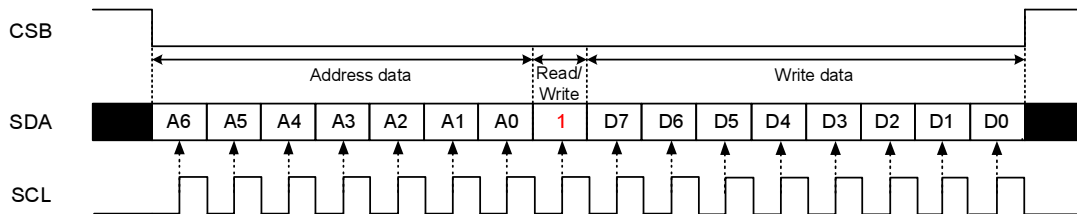

**5.2 3-Wire Control Register List**

NO.	Address								MSB	Initial value								LSB
	A6	A5	A4	A3	A2	A1	A0	R/W		D7	D6	D5	D4	D3	D2	D1	D0	
R2	0	0	0	0	0	1	0	RW(0)				CONTRAST_SW	CONTRAST_A					
									0	0	0	1	0	1	0	0		
R3	0	0	0	0	0	1	1	RW(0)	BRIGHTNESS (40h)									
R5	0	0	0	0	1	0	1	RW(0)		GRB						STB		
									0	1	0	1	1	1	0			
R6	0	0	0	0	1	1	0	RW(0)	HBLK_EN			VBLK (08h)						
									0	0	0							
R7	0	0	0	0	1	1	1	RW(0)	HBLK (28h)									
R8	0	0	0	1	0	0	0	RW(0)	(00h)	(000h)			PS_Timing_SEL (000h)					
R12	0	0	0	1	1	0	0	RW(0)					DEpol	Vdpol	Hdpol	DCLK		
									0	0	0	0	0	1	1	0		
R13	0	0	0	1	1	0	1	RW(0)	CONTRAST_GRB (40h)									
R14	0	0	0	1	1	1	0	RW(0)	SUB_CONTRAST_R (40h)									
R15	0	0	0	1	1	1	1	RW(0)	SUB_BRIGHTNESS_R (40h)									
R16	0	0	1	0	0	0	0	RW(0)	SUB_CONTRAST_B (40)									
R17	0	0	1	0	0	0	1	RW(0)	SUB_BRIGHTNESS_B (40)									



### 5.3 Suggested Serial Command Settings

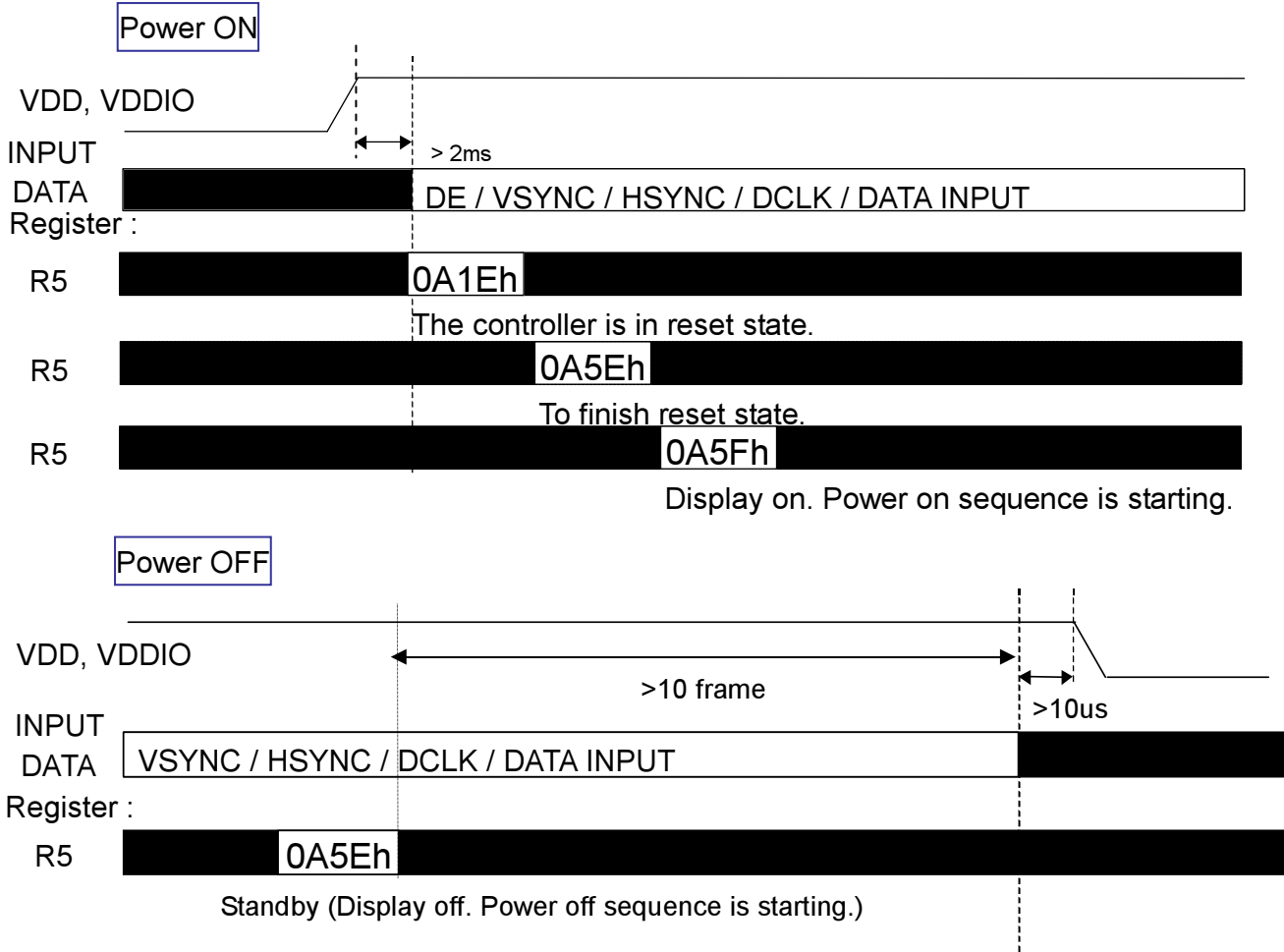

### 5.4 3-wire Registers Function Description

#### R02 Register

Bit	Name	Initial	R/W	Description
Bit[7:5]	-	-	-	Reserve
Bit [4]	CONTRAST_SW	01h	R/W	4-bit or 8-bit contrast selection. CONTRAST_SW = "0", 4bit contrast, Contrast_A(R02) CONTRAST_SW = "1", 8bit contrast, Contrast_RGB(R13). (Default)
Bit[3:0]	CONTRAST_A[3:0]	04h	R/W	RGB contrast level setting.

#### CONTRAST\_A: RGB contrast level setting, the gain changes 0.25 / bit.

CONTRAST_A[3:0]	Contrast level
00h	0
:	:
04h(Default)	1
:	:
0Fh	3.75

**R03 Register**

Bit	Name	Initial	R/W	Description
Bit[7:0]	BRIGHTNESS[7:0]	40h	R/W	Display Brightness level adjustment register. (1 step/bit) Adjust range from 00h(level = -64) to FFh(level = +191) <b>Default value 40h(level = +0)</b>

**BRIGHTNESS: RGB brightness level setting, setting accuracy: 1 step / bit**

BRIGHTNESS[7:0]	Brightness level
00h	Dark(-64)
:	:
40h( <b>Default</b> )	Center(0)
:	:
FFh	Bright(+191)

**R05 Register**

Bit	Name	Initial	R/W	Description
Bit [6]	GRB	01h	R/W	Register reset setting. GRB = "0", Reset all registers to default value. GRB = "1", Normal operation. ( <b>Default</b> )
Bit [0]	STB	00h	R/W	Standby (Power saving) mode setting. STB = "0", Standby; timing control, DAC, and DC/DC converter are off, and register data should be kept. ( <b>Default</b> ) STB = "1", Normal operation, with power on/off sequence.

**R06 Register**

Bit	Name	Initial	R/W	Description
Bit[7]	HBLK_EN	00h	R/W	Horizontal blanking setting enable. HBLK_EN = "0", Horizontal blanking setting disable. ( <b>Default</b> ) HBLK_EN = "1", Horizontal blanking setting enable.
Bit[4:0]	VBLK[4:0]	08h	R/W	Vertical blanking setting.

**VBLK: Vertical blanking setting**

VBLK[4:0]	Vertical blanking	Unit
01h	1	H
:	:	
08h( <b>Default</b> )	8	
:	:	
1Fh	31	

Note: SYNC mode only.

**R07 Register**

Bit	Name	Initial	R/W	Description
Bit[7:0]	HBLK	28h	R/W	Horizontal blanking setting.

**HBLK\_EN & HBLK: Horizontal blanking setting**

HBLK_EN	HBLK[7:0] (HEX)	HBLK[7:0] (Decimal)	Unit	Remark
1	05h	5	DCLK(*)	Parallel 480RGBx272 Parallel 400RGBx240 Parallel 320RGBx240
	28h(Default)	40(Default)		
	FFh	255		
0	28h	40(Fixed)		
1	32h	50	DCLK(*)	Serial 480RGBx272 Serial 400RGBx240 Serial 320RGBx240
	64h	100(Default)		
	FFh	255		
0	64h	100(Fixed)		

\*The frequency of DCLK is different under different input timing.

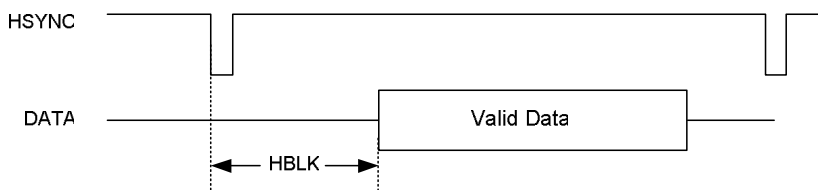

**R08 Register**

Bit	Name	Initial	R/W	Description
Bit[2:0]	PS_Timing_SEL[2:0]	00h	R/W	DE or SYNC mode input timing selection.
				PS_Timing_SEL[2:0] Input data format
				0xx Setting by input pin SYNC. <b>(Default)</b>
				100 DE input timing
				101 SYNC input timing

**Note:** The SYNC pin default setting is in DE mode.

**R12 Register**

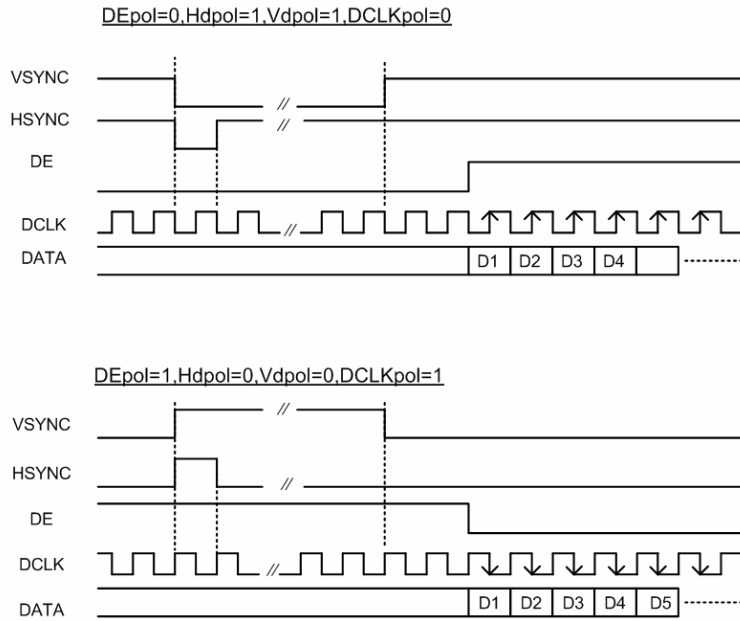
Bit	Name	Initial	R/W	Description
Bit[7:4]	-	-	-	Reserve
Bit[3]	DEpol	00h	R/W	DE polarity selection. DEpol = "0", Positive polarity. <b>(Default)</b> DEpol = "1", Negative polarity
Bit[2]	Vdpol	01h	R/W	VSYNC polarity selection. Vdpol = "0", Positive polarity. Vdpol = "1", Negative polarity. <b>(Default)</b>
Bit[1]	Hdpol	01h	R/W	HSYNC polarity selection. Hdpol = "0", Positive polarity. Hdpol = "1", Negative polarity. <b>(Default)</b>
Bit[0]	DCLKpol	00h	R/W	DCLK polarity selection. DCLKpol = "0", Positive polarity. <b>(Default)</b> DCLKpol = "1", Negative polarity



### R13 Register

Bit	Name	Initial	R/W	Description
Bit[7:0]	CONTRAST_RGB[7:0]	40h	R/W	RGB contrast level setting.

### CONTRAST\_RGB: RGB contrast level setting, the gain changes (1/64) / bit

CONTRAST_RGB[7:0]	Contrast level
00h	0
:	:
40h(Default)	1
:	:
FFh	3.984

### R14 Register

Bit	Name	Initial	R/W	Description
Bit[7]	-	-	-	Reserve.
Bit[6:0]	SUB-CONTRAST_R[6:0]	40h	R/W	R sub-contrast level setting.

### R16 Register

Bit	Name	Initial	R/W	Description
Bit[7]	-	-	-	Reserve.
Bit[6:0]	SUB-CONTRAST_B[6:0]	40h	R/W	B sub-contrast level setting.

### SUB-CONTRAST: R/B sub-contrast level setting, the gain changes (1/256) / bit

SUB-CONTRAST_R/B[6:0]	Sub-Contrast level
00h	0.75

:	:
40h(Default)	1
:	:
7Fh	1.246

### R15 Register

Bit	Name	Initial	R/W	Description
Bit[7]	-	-	-	Reserve.
Bit[6:0]	SUB-BRIGHTNESS_R[6:0]	40h	R/W	R sub-brightness level setting.

### R17 Register

Bit	Name	Initial	R/W	Description
Bit[7]	-	-	-	Reserve.
Bit[6:0]	SUB-BRIGHTNESS_B[6:0]	40h	R/W	B sub-brightness level setting.

**SUB-BRIGHTNESS:** R/B sub-brightness level setting, setting accuracy 1 step / bit

SUB-BRUGHTNESS_R/B[6:0]	Sub-Brightness level
00h	Dark(-64)
:	:
40h(Default)	Center(0)
:	:
7Fh	Bright(+63)

### Contrast / Brightness circuit

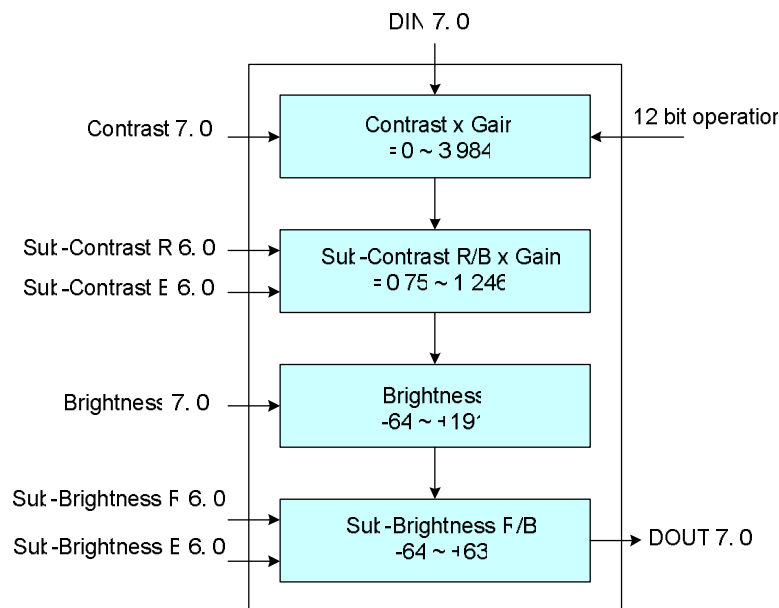

### Contrast Circuit

- 8-bit serial setting to control the contrast (gain) for RGB signals
- 7-bit sub-contrast adjustment for R/B

$$DOUT\_G[7:0] = DIN[7:0] \times Contrast[0 \text{ to } 1.0 \text{ to } 3.984]$$

$$DOUT\_R[7:0] = DIN[7:0] \times Contrast[0 \text{ to } 1.0 \text{ to } 3.984] \times \text{sub-contrast R} [0.75 \text{ to } 1.0 \text{ to } 1.246]$$

$$DOUT\_B[7:0] = DIN[7:0] \times Contrast[0 \text{ to } 1.0 \text{ to } 3.984] \times \text{sub-contrast B} [0.75 \text{ to } 1.0 \text{ to } 1.246]$$

Note: output values above “255” clipped.

<b>CONTRAST</b>	<b>00h</b>	<b>to</b>	<b>40h(Default)</b>	<b>to</b>	<b>FFh</b>
<b>Gain value range</b>	<b>0</b>	<b>to</b>	<b>1</b>	<b>to</b>	<b>3.984</b>

<b>SUB-CONTRAST R/B</b>	<b>00h</b>	<b>to</b>	<b>40h(Default)</b>	<b>to</b>	<b>7Fh</b>
<b>Gain value range</b>	<b>0.75</b>	<b>to</b>	<b>1</b>	<b>to</b>	<b>1.246</b>

### Brightness Circuit

- 8-bit serial setting to control the RGB brightness level
- 7-bit serial setting to control the R/B sub-brightness level

$$DOUT\_G[7:0] = DIN\_G[7:0] + Bright[-64 \text{ to } 0 \text{ to } +191]$$

$$DOUT\_R[7:0] = DIN\_R[7:0] + Bright[-64 \text{ to } 0 \text{ to } +191] + \text{Sub-bright R}[-64 \text{ to } 0 \text{ to } +63]$$

$$DOUT\_B[7:0] = DIN\_B[7:0] + Bright[-64 \text{ to } 0 \text{ to } +191] + \text{Sub-bright B}[-64 \text{ to } 0 \text{ to } +63]$$

Note: Output values below “0” and above “255” clipped.

<b>BRIGHTNESS</b>	<b>00h</b>	<b>to</b>	<b>40h(Default)</b>	<b>to</b>	<b>FFh</b>
<b>Variable range</b>	<b>-64</b>	<b>to</b>	<b>0</b>	<b>to</b>	<b>+191</b>

<b>SUB-BRIGHTNESS R/B</b>	<b>00h</b>	<b>to</b>	<b>40h(Default)</b>	<b>to</b>	<b>7Fh</b>
<b>Variable range</b>	<b>-64</b>	<b>to</b>	<b>0</b>	<b>to</b>	<b>+63</b>

## 6. Power On/Off Characteristics

### a. Recommended Power On Sequence

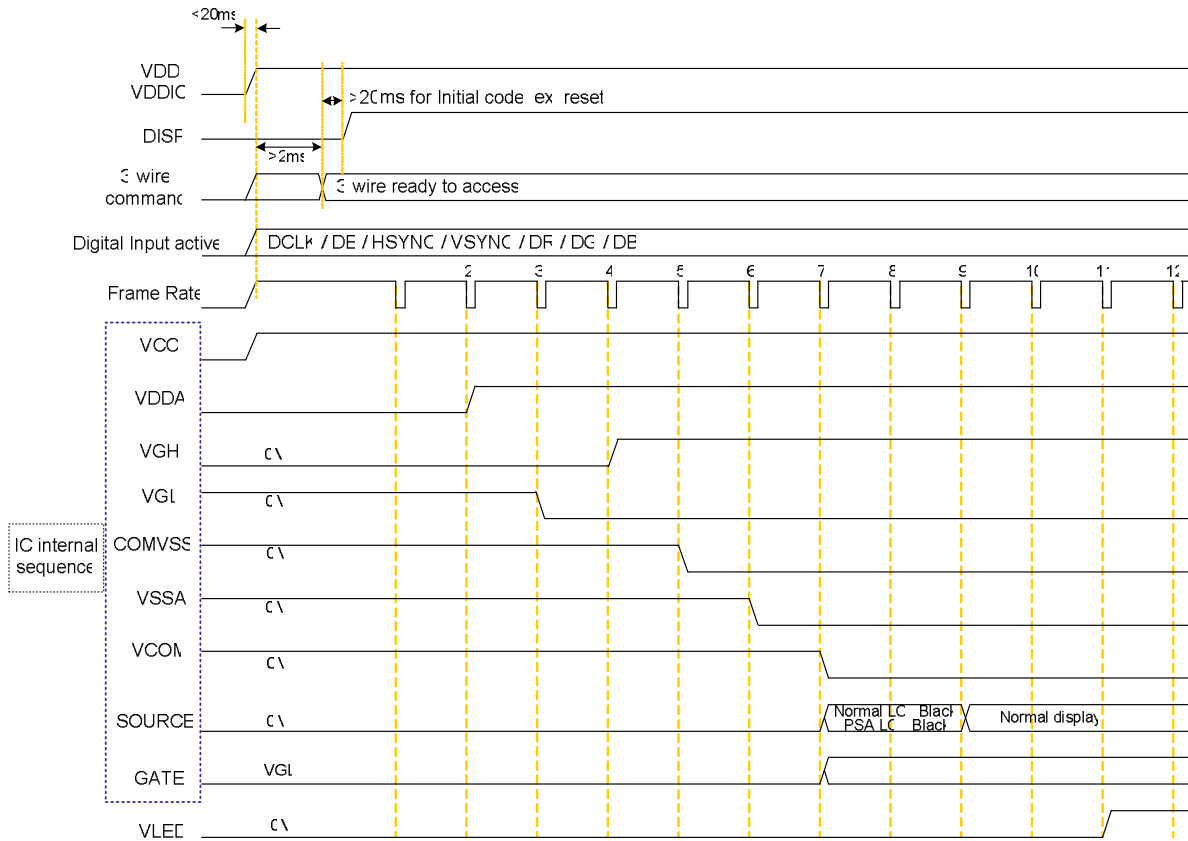

### b. Recommended Power Off Sequence

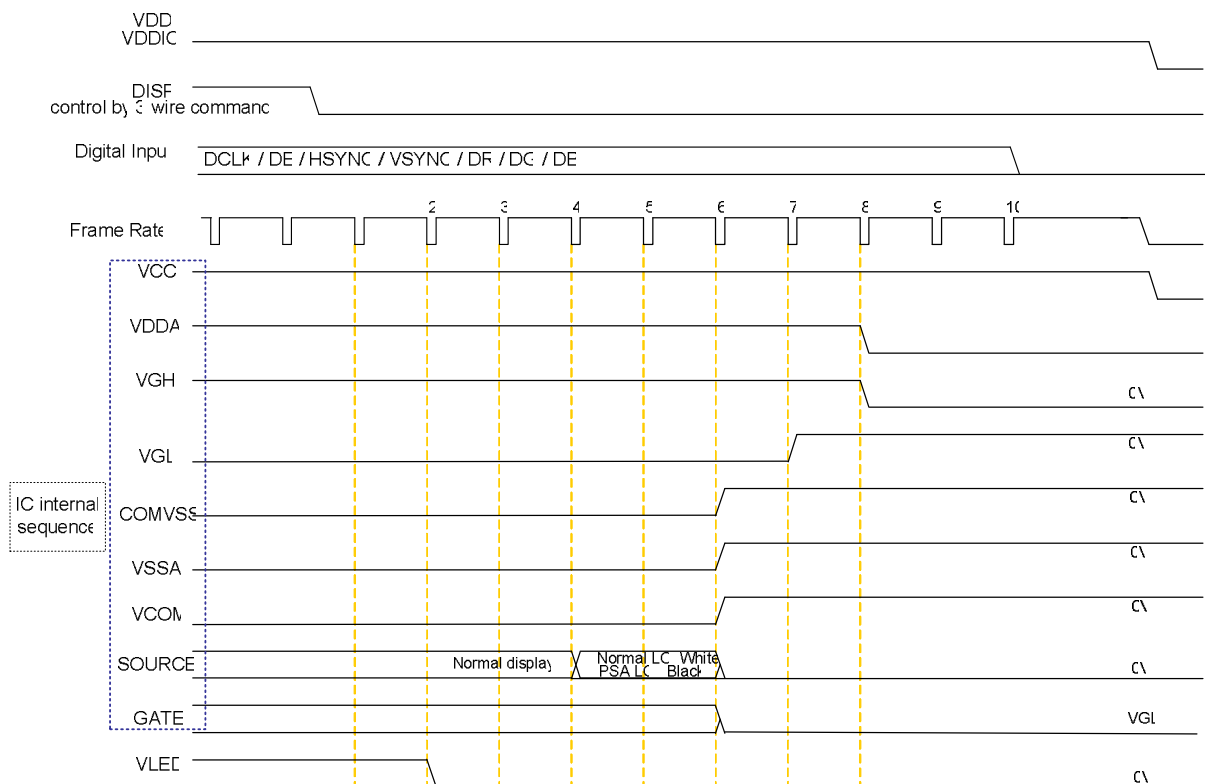

## D. Optical Specification

All optical specification is measured under typical condition (Note 1, 2)

Item	Symbol	Condition	Min.	Typ.	Max.	Unit	Remark
Response Time Rise	Tr	$\theta=0^\circ$	-	7	-	ms	Note 3
	Tf		-	23	-	ms	
Contrast ratio	CR	At optimized viewing	400	500	-		Note 4
Viewing Angle	Top	$CR \geq 10$	-	40	-	deg.	Note 5
	Bottom		-	60	-		
	Left		-	70	-		
	Right		-	70	-		
Brightness	$Y_L$	$\theta=0^\circ$	320	400	-	$cd/m^2$	Note 6
Chromaticity	Rx	$\theta=0^\circ$	0.550	0.590	0.630		
	Ry	$\theta=0^\circ$	0.304	0.344	0.384		
	Gx	$\theta=0^\circ$	0.285	0.325	0.365		
	Gy	$\theta=0^\circ$	0.537	0.577	0.617		
	Bx	$\theta=0^\circ$	0.112	0.152	0.192		
	By	$\theta=0^\circ$	0.080	0.120	0.160		
	Wx	$\theta=0^\circ$	0.270	0.31	0.350		
	Wy	$\theta=0^\circ$	0.290	0.33	0.370		
Uniformity	$\Delta Y_L$	%	70	80	--	%	Note 7

Note 1: Ambient temperature  $\approx 25^\circ C$ , and LED lightbar current  $I_L = 40 \text{ mA}$ . To be measured in the dark room.

Note 2: To be measured on the center area of panel with a viewing cone of  $1^\circ$  by Topcon luminance meter BM-5A, after 15 minutes operation.

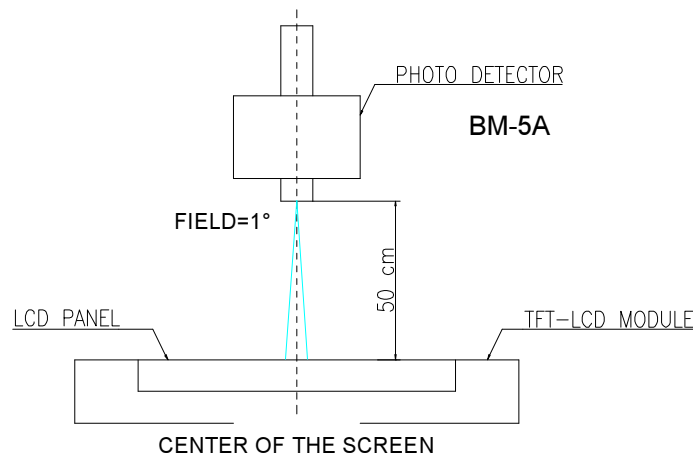



Note 3: Definition of response time:

The output signals of photo detector are measured when the input signals are changed from “black” to “white”(falling time) and from “white” to “black”(rising time), respectively.

The response time is defined as the time interval between the 10% and 90% of amplitudes.

Refer to figure as below.

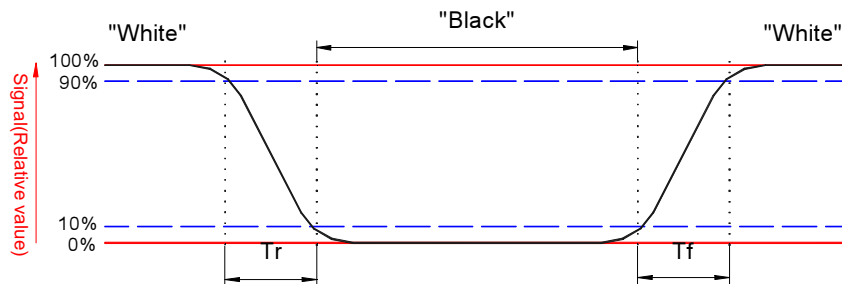

Note 4. Definition of contrast ratio:

Contrast ratio is calculated with the following formula.

$$\text{Contrast ratio (CR)} = \frac{\text{Photo detector output when LCD is at "White" status}}{\text{Photo detector output when LCD is at "Black" status}}$$

Note 5. Definition of viewing angle,  $\theta$ , Refer to figure as below.

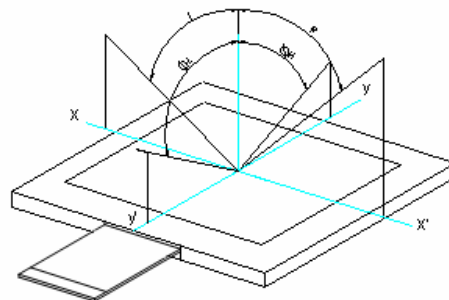

Note 6. Measured at the center area of the panel when all the input terminals of LCD panel are electrically opened.

Note 7: Luminance Uniformity of these 9 points is defined as below:

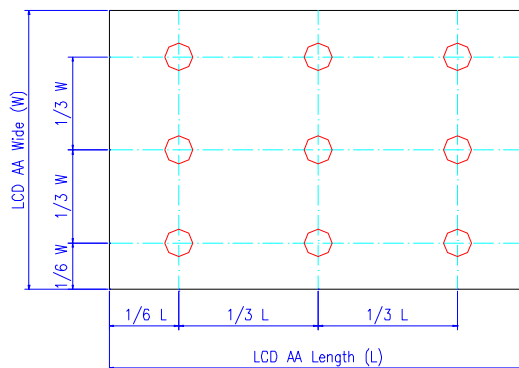

$$\text{Uniformity} = \frac{\text{minimum luminance in 9 points (1-9)}}{\text{maximum luminance in 9 points (1-9)}}$$

## E. Touch Screen Panel Specifications

### 1. FPC Pin Assignment

Pin No.	Symbol	I/O	Description
1	X1	I/O	Touch panel right electrode (R)
2	Y2	I/O	Touch panel bottom electrode (B)
3	X2	I/O	Touch panel left electrode (L)
4	Y1	I/O	Touch panel top electrode (U)

### 2. Electrical Characteristics

Item	Min.	Typ	Max.	Unit	Remark	
Rate DC Voltage	--	--	5	V		
Resistance	X (Film)	300	--	1600	$\Omega$	At connector
	Y (Glass)	50	--	800		
Linearity	-1.5%		1.5%	--	Note 1	
Response Time			15	ms		
Insulation Resistance	20			M $\Omega$	DC 25V	

Note 1: Measurement condition of Linearity: difference between actual voltage & theoretical voltage is an error at any points. Linearity is the value max. error voltage divided by voltage difference on active area.

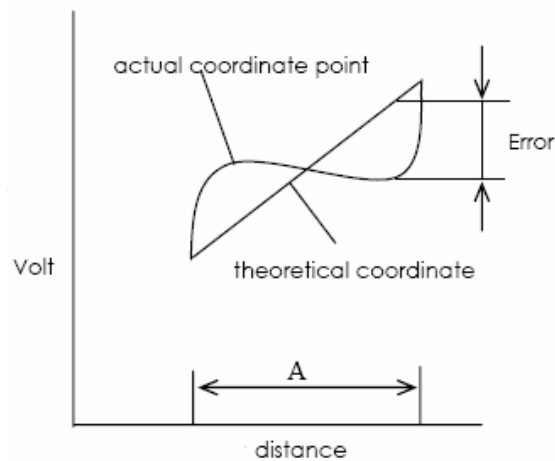

### 3. Mechanical Characteristics

Item	Min.	Max.	Unit	Remark
Hardness of Surface	3	--	H	JIS K-5600
Operation Force (Pen or Finger)	--	80	gf	Note 1, 2

Note 1: Within "active area", but not near the active area boundary and on the dot-spacer.

Note 2: Operation force measurement is under test condition as figure below.

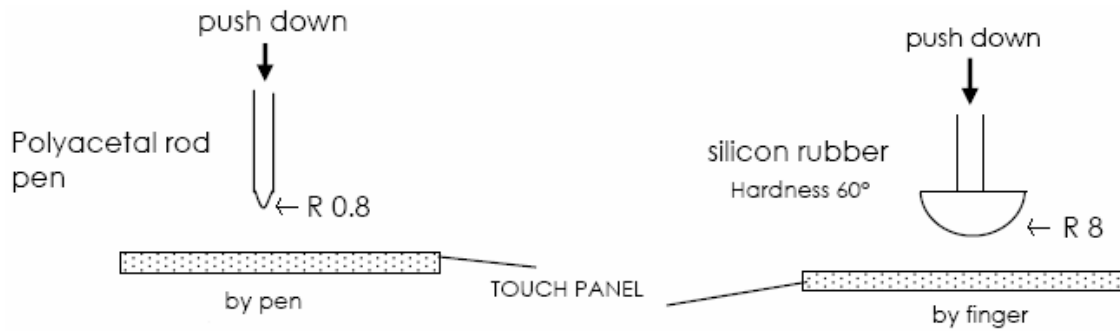

### 4. Life Test Condition

Item	Min.	Max.	Unit	Remark
Notes Life	$10^5$	--	lines	Note 1, 2
Input Life	$10^6$	--	times	Note 1, 3

Note 1: Notes Life test condition (by pen): slide on central 2/3 of active area and use R 0.8mm polyacetal pen, input force : 250gf, frequency : 60mm/sec. Sliding from A to B complete 1 time. shown as figure.

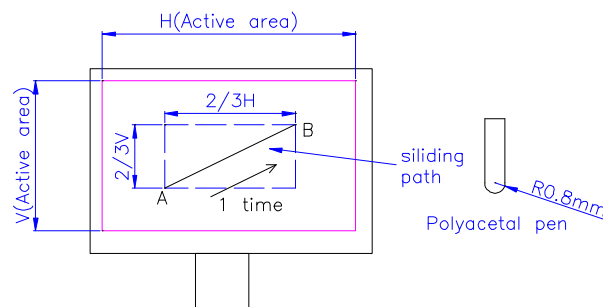

Note 2: Input Life test condition (by finger): test position on active area center and use R8.0mm silicon rubber (hardness 60°), test force: 250gf, frequency : 2times/sec. shown as figure.

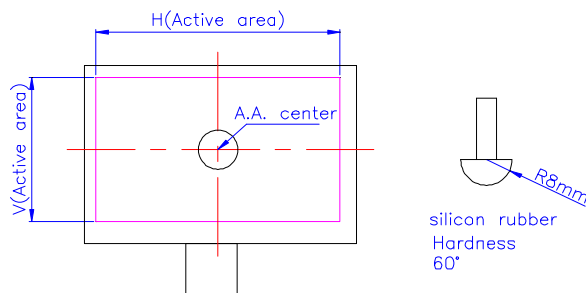

## 5. Attention

Please pay attention for below matters at mounting design for touch panel of LCD module.

- 1) To prevent abnormal work on touch function, casing and T/P ITO film should have a gap.  
Suggestion design show as below figure.
- 2) Cushion area and casing opening must be followed mechanical drawing.
- 3) Don't use glue, hard or conductive material as a cushion to enclosure touch panel.
- 4) The touch panel edge is conductive. Do not touch it with any conductive part after mounting.

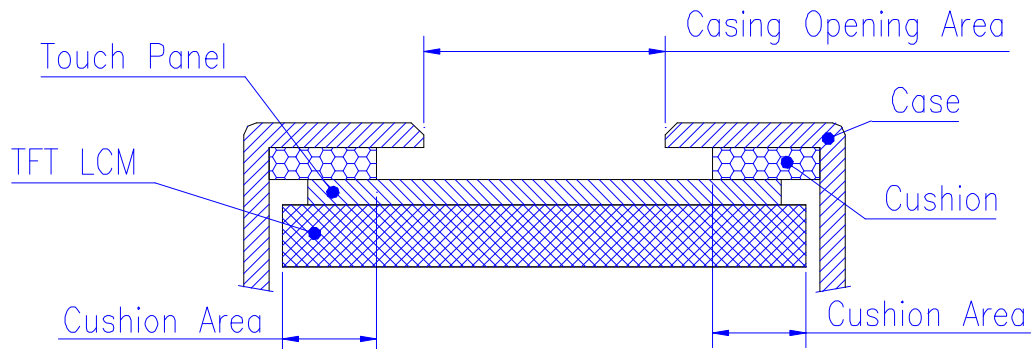

- 5) If users want to cleaning touch panel by air gun, pressure  $2\text{kg}/\text{cm}^2$  below is suggested.
- 6) Do not input with a heavy shock or stress on touch panel and film surface. Ex. Don't transfer the panel from film face with vacuum.
- 7) Do not lift LCD module by FPC.
- 8) Please use dry cloth or soft cloth with neutral detergent (after wring dry) or one with ethanol at cleaning. Do not use any organic solvent, acid or alkali solution.
- 9) Do not pile touch panels. Do not put heavy goods on touch panels.

## F. Reliability Test Items

No.	Test items	Conditions	Remark
1	High Temperature Storage	Ta= 80°C      240Hrs	
2	Low Temperature Storage	Ta= -30°C      240Hrs	
3	High Ttemperature Operation	Tp= 70°C      240Hrs	
4	Low Temperature Operation	Ta= -20°C      240Hrs	
5	High Temperature & High Humidity	Tp= 60°C, 90% RH      240Hrs	Operation
6	Heat Shock	-25°C ~70°C, 50 cycle, 2Hrs/cycle	Non-operation
7	Electrostatic Discharge	Contact = ± 4 kV, class B Air = ± 8 kV, class B	Note 4
8	Image Sticking	25°C, 4hrs	Note 5
9	Vibration	Frequency range : 8~33.3Hz Stoke : 1.3mm Sweep : 2.9G ,33.3~400Hz 2 hours for each direction of X,Y,Z 4 hours for Y direction	Non-operation JIS C7021, A-10 condition A : 15 minutes
10	Mechanical Shock	100G . 6ms, ±X,±Y,±Z 3 times for each direction	Non-operation JIS C7021, A-7 condition C
11	Vibration (With Carton)	Random vibration: 0.015G <sup>2</sup> /Hz from 5~200Hz -6dB/Octave from 200~500Hz	IEC 68-34
12	Drop (With Carton)	Height: 60cm 1 corner, 3 edges, 6 surfaces	
13	Pressure	5kg, 5sec	Note 6

Note 1: Ta: Ambient Temperature. Tp: Panel Surface Temperature

Note 2: In the standard conditions, there is not display function NG issue occurred. All the cosmetic specification is judged before the reliability stress.

Note 3: All the cosmetic specification is judged before the reliability stress.

Note 4 : All test techniques follow IEC6100-4-2 standard.

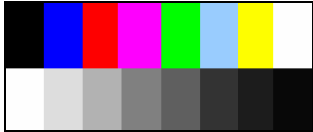
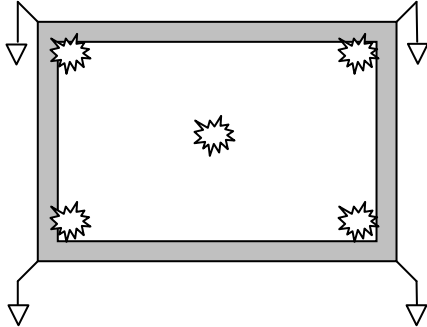
Test Condition			Note
Pattern			
Procedure And Set-up	<p data-bbox="424 427 1165 456"><u>Contact Discharge</u> : 330Ω, 150pF, 1sec, 5point, 10times/point</p> <p data-bbox="424 472 1110 501"><u>Air Discharge</u> : 330Ω, 150pF, 1sec, 5 point, 10times/point</p>  <p data-bbox="424 891 497 920"><u>Note</u> :</p> <ol data-bbox="424 943 1182 1059" style="list-style-type: none"> <li>1. The metal casing is connected to ground (0V) at four corners.</li> <li>2. All register commands are repeating transferred.</li> <li>3. Judging the result after discharging.</li> </ol>		
Criteria	<p data-bbox="424 1077 1246 1149">B – Some performance degradation allowed. No data lost. Self-recoverable hardware failure.</p>		
Others	<ol data-bbox="424 1171 1026 1243" style="list-style-type: none"> <li>1. Gun to Panel Distance</li> <li>2. No SPI command, keep default register settings.</li> </ol>		

Note 5: Operate with chess board pattern as figure and lasting time and temperature as the conditions.  
Then judge with 50% gray level, the mura is less than JND 2.8

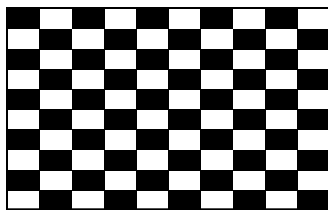

Note 6: The panel is tested as figure. The jig is  $\phi$  10 mm made by Cu with rubber and the loading speed is 3mm/min on position A~E. After the condition, no glass crack will be found and panel function check is OK.( no guarantee LC mura \ LC bubble)

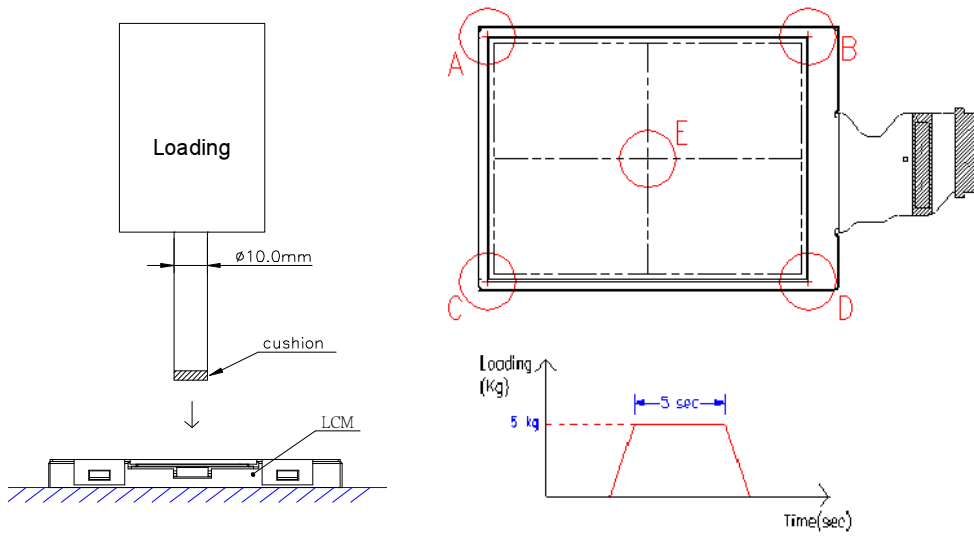



**G. Packing and Marking**  
**1. Packing Form**

TBD



## H. Application Note

### 1. Application Circuit

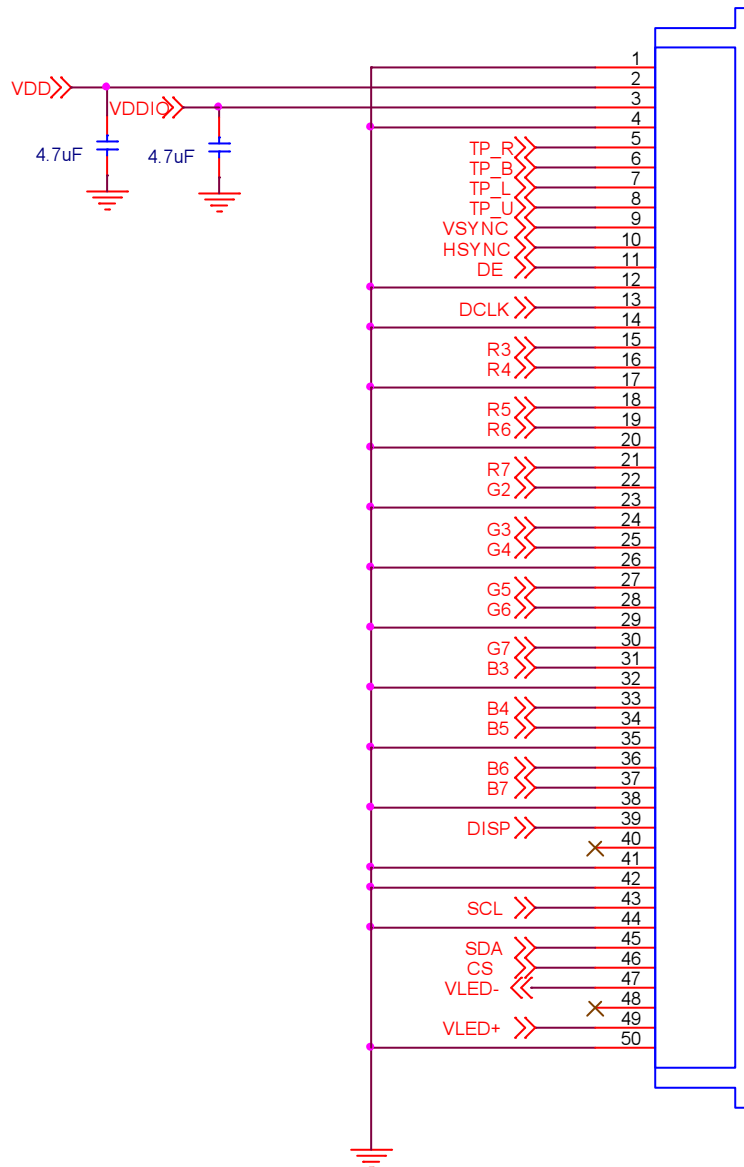

## I. Precautions

1. Do not twist or bend the module and prevent the unsuitable external force for display module during assembly.
2. Adopt measures for good heat radiation. Be sure to use the module with in the specified temperature.
3. Avoid dust or oil mist during assembly.
4. Follow the correct power sequence while operating. Do not apply the invalid signal, otherwise, it will cause improper shut down and damage the module.
5. Less EMI: it will be more safety and less noise.
6. Please operate module in suitable temperature. The response time & brightness will drift by different temperature.
7. Avoid to display the fixed pattern (exclude the white pattern) in a long period, otherwise, it will cause image sticking.
8. Be sure to turn off the power when connecting or disconnecting the circuit.
9. Polarizer scratches easily, please handle it carefully.
10. Display surface never likes dirt or stains.
11. A dewdrop may lead to destruction. Please wipe off any moisture before using module.
12. Sudden temperature changes cause condensation, and it will cause polarizer damaged.
13. High temperature and humidity may degrade performance. Please do not expose the module to the direct sunlight and so on.
14. Acetic acid or chlorine compounds are not friends with TFT display module.
15. Static electricity will damage the module, please do not touch the module without any grounded device.
16. Do not disassemble and reassemble the module by self.
17. Be careful do not touch the rear side directly.
18. No strong vibration or shock. It will cause module broken.
19. Storage the modules in suitable environment with regular packing.
20. Be careful of injury from a broken display module.
21. Please avoid the pressure adding to the surface (front or rear side) of modules, because it will cause the display non-uniformity or other function issue.