

CUSTOMER APPROVAL SHEET

Company Name	
MODEL	A050VW01 V1
CUSTOMER APPROVED	Title : Name :

- APPROVAL FOR SPECIFICATIONS ONLY (Spec. Ver.____)
- APPROVAL FOR SPECIFICATIONS AND ES SAMPLE (Spec. Ver.____)
- APPROVAL FOR SPECIFICATIONS AND CS SAMPLE (Spec. Ver.____)
- CUSTOMER REMARK :

AUO PM :

P/N : 97.05A07.100

Comment :



Doc. version :	0.0
Total pages :	21
Date :	2008/10/07

Product Specification

5.0" COLOR TFT-LCD MODULE

MODEL NAME: A050VW01 V1

< > Preliminary Specification
< > Final Specification

Note: The content of this specification is subject to change.

© 2008 AU Optronics
All Rights Reserved,
Do Not Copy.



Record of Revision

Version	Revise Date	Page	Content
0.0	2008/10/07		First draft.

ALL RIGHTS RESERVED FROM AU OPTRONICS CORP.

Contents

A. General Information	3
B. Outline Dimension	4
1. TFT-LCD Module – Front View	4
2. TFT-LCD Module – Rear View	5
C. Electrical Specifications	6
1. TFT LCD Panel Pin Assignment	6
2. Absolute Maximum Ratings	8
3. Electrical DC Characteristics	8
4. Electrical AC Characteristics	10
5. Power On/Off Characteristics	12
D. Optical Specification	13
E. Reliability Test Items	16
F. Packing and Marking	19
1. Packing Form	19
2. Module/Panel Label Information	20
3. Carton Label Information	20
G. Precautions	21

A. General Information

This product is for PND and MID applications.

NO.	Item	Unit	Specification	Remark
1	Screen Size	inch	5.0(Diagonal)	
2	Display Resolution	dot	800RGB(H)×480(V)	
3	Overall Dimension	mm	119.6(H) × 76.5(V) × 2.84(T)	Note 1
4	Active Area	mm	108.0(H)×64.8(V)	
5	Pixel Pitch	mm	0.045(H)×0.135(V)	
6	Color Configuration	--	R. G. B. Stripe	Note 2
7	Color Depth	--	16.7M Colors	Note 3
8	NTSC Ratio	%	50	
9	Display Mode	--	Normally White	
10	Panel surface Treatment	--	Anti-Glare, 3H	
11	Weight	g	57.8	
12	Panel Power Consumption	W	1.2	Note 4
13	Backlight Power Consumption	mW	896	
14	Viewing direction		6 o'clock (gray inversion)	

Note 1: Not include FPCs. Refer next page to get further information.

Note 2: Below figure shows dot stripe arrangement.

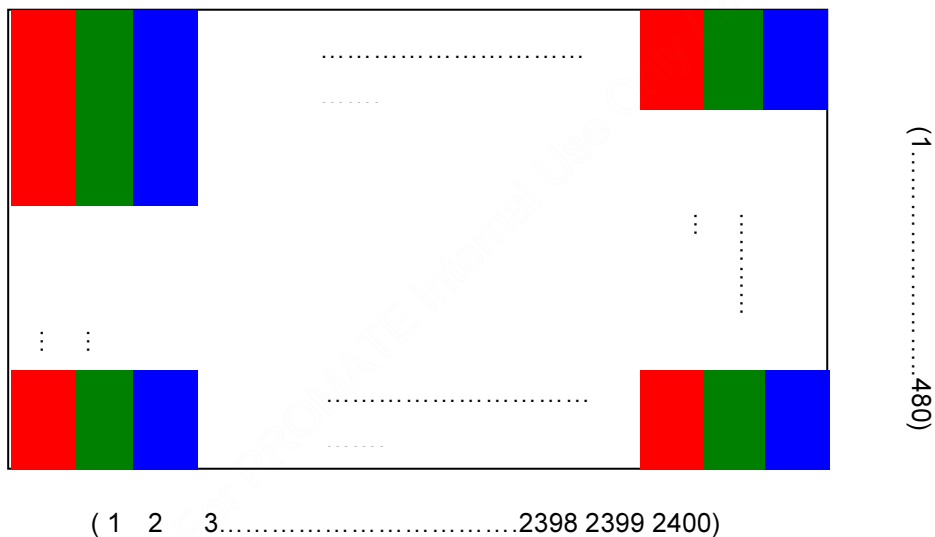

Note 3: The full color display depends on 24-bit data signal (pin 5~28).

Note 4: Please refer to Electrical Characteristics chapter.



B. Outline Dimension
1. TFT-LCD Module – Front View

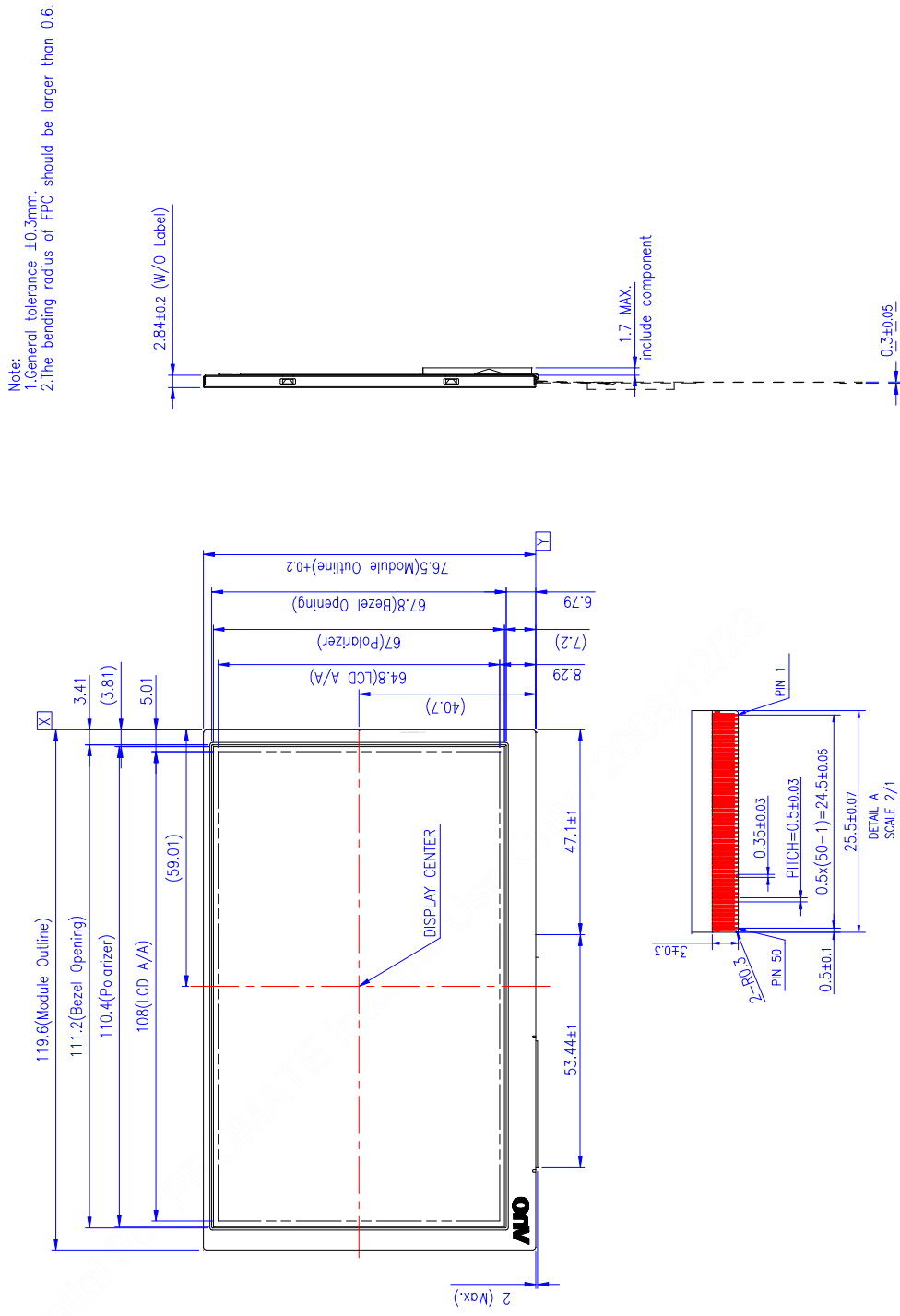

2. TFT-LCD Module – Rear View

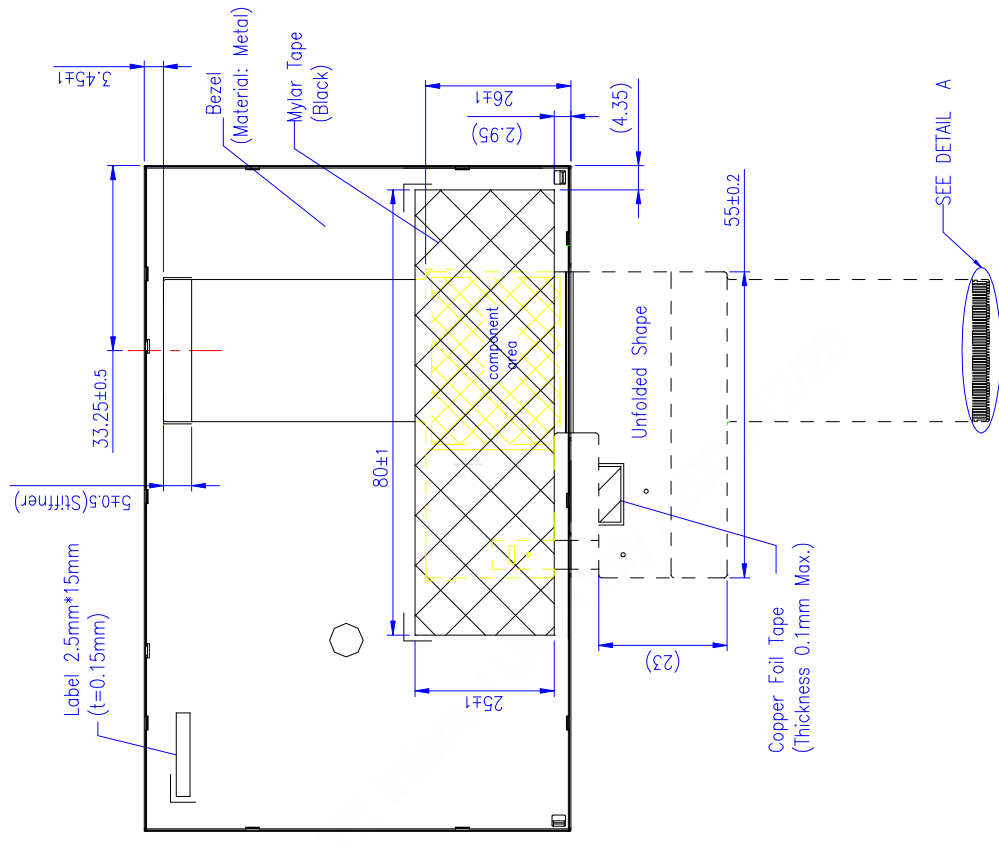

C. Electrical Specifications

1. TFT LCD Panel Pin Assignment

Recommended connector : FH12-50S-0.5SH

Pin No.	Symbol	Type	Description	Remark
1	GND	P	Ground for digital circuit	
2	GND	P	Ground for digital circuit	
3	VDD	P	DC-DC circuit supply voltage	
4	VDD	P	DC-DC circuit supply voltage	
5	DR0	I	Red Data input; LSB	
6	DR1	I	Red Data input	
7	DR2	I	Red Data input	
8	DR3	I	Red Data input	
9	DR4	I	Red Data input	
10	DR5	I	Red Data input	
11	DR6	I	Red Data input	
12	DR7	I	Red Data input; MSB	
13	DG0	I	Green Data input; LSB	
14	DG1	I	Green Data input	
15	DG2	I	Green Data input	
16	DG3	I	Green Data input	
17	DG4	I	Green Data input	
18	DG5	I	Green Data input	
19	DG6	I	Green Data input	
20	DG7	I	Green Data input; MSB	
21	DB0	I	Blue Data input; LSB	
22	DB1	I	Blue Data input	
23	DB2	I	Blue Data input	
24	DB3	I	Blue Data input	
25	DB4	I	Blue Data input	
26	DB5	I	Blue Data input	
27	DB6	I	Blue Data input	
28	DB7	I	Blue Data input; MSB	

29	GND	P	Ground for digital circuit	
30	DCLK	I	Data clock Input	
31	DISP	I	Standby mode control pin. Normally pull high. DISP = "1", normal operation. DISP = "0", standby mode.	
32	NC	-	Not connected. Please leave it open.	
33	NC	-	Not connected. Please leave it open.	
34	DE	I	Data enable input. Active level is high.	
35	U/D	I	U/D = "1", Down scan. U/D = "0", Up scan.	
36	NC	-	No connection. Please leave it open	
37	GND	P	Ground for digital circuit	
38	GND	P	Ground for digital circuit	
39	NC	-	Not connected. Please leave it open.	
40	NC	-	Not connected. Please leave it open.	
41	NC	-	Not connected. Please leave it open.	
42	NC	-	Not connected. Please leave it open.	
43	NC	-	No connection. Please leave it open	
44	NC	-	No connection. Please leave it open	
45	NC	-	No connection. Please leave it open	
46	VLED-	P	Backlight LED cathode	
47	VLED+	P	Backlight LED anode	
48	GND	P	Ground for digital circuit	
49	GND	P	Ground for digital circuit	
50	GND	P	Ground for digital circuit	

Note 1: I: Input; O: Output; P: Power.

Note 2: For correct power on sequence please refer to section 5 "Power On/Off Sequence"

2. Absolute Maximum Ratings

Item	Symbol	Condition	Min.	Max.	Unit	Remark
Power voltage	VDD	GND=0	-0.3	4.5	V	Note 1
Input signal voltage	Data	GND=0	-0.3	VDD+0.3	V	Digital signal

Note 1: Functional operation should be restricted under ambient temperature (25°C).

Note 2: Maximum ratings are those values beyond which damages to the device may occur. Functional operation should be restricted to the limits in the Electrical Characteristics chapter.

3. Electrical DC Characteristics

a. Typical Operation Condition (AGND =GND = 0V)

Item	Symbol	Min.	Typ.	Max.	Unit	Remark
Power supply	VDD	3.1	3.3	3.5	V	
Input high voltage	VIH	0.7*VDD	-	VDD	V	
Input low voltage	VIL	0	-	0.3*VDD		

b. Current Consumption (AGND=GND=0V)

Parameter	Symbol	Condition	Min.	Typ.	Max.	Unit	Remark
Input Current for VDD	I _{VDD}	VDD=3.3V	-	90	110	mA	Note 1, 2
	I _{VDD} (STANDBY)	VDD=3.3V	-	10	50	uA	Note 3

Note 1: Test Condition is under typical Electrical DC and AC characteristics.

Note 2: Test pattern is the following picture (color bar).



Note 3: In standby mode, all digital signals are stopped. Ex. DCLK, DE ...etc.

c. Backlight Driving Conditions

The backlight (LED module, Note 1) is suggested to drive by constant current with typical value.

Parameter	Symbol	Min.	Typ.	Max.	Unit	Remark
LED Current	I _L	--	20	22	mA	Note 1
Power	P _L	--	896	1108	mW	
LED Life Time	L _L	10,000	--	--	Hr	Note 2, 3

Note 1: LED backlight is two parallel strings and one LED for each string is as below figure. Suggest drive by 20mA for each LED string.

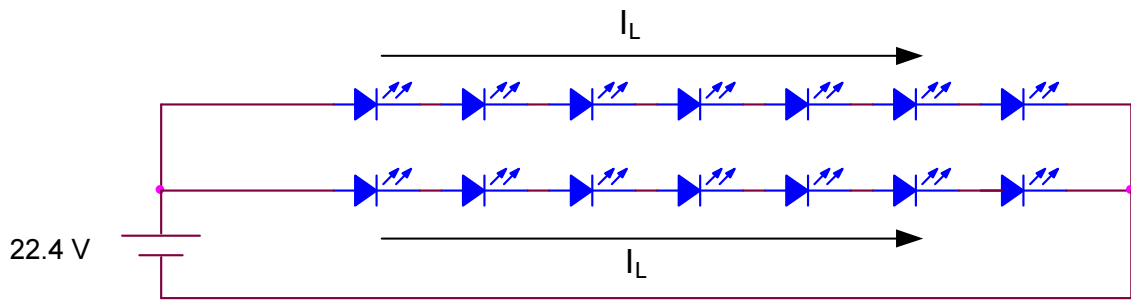

Note 2: Define "LED Lifetime": brightness is decreased to 50% of the initial value. LED Lifetime is restricted under normal condition, ambient temperature = 25°C and LED lightbar current = 20 mA.

Note 3: If it uses larger LED lightbar voltage/ current more than 20mA, it maybe decreases the LED lifetime.

WWW.AUOPTRONICS.COM/PRODUCTS/LED-LIGHTBAR/

4. Electrical AC Characteristics

a. Signal AC Characteristics

Parameter	Symbol	Min.	Typ.	Max.	Unit	Remark
DCLK duty cycle	--	40	50	60	%	$t_{cw} / t_{DCLK} \times 100\%$
DE setup time	T_{est}	8	--	--	ns	
DE hold time	T_{ehd}	8	--	--	ns	
Data setup time	t_{dst}	8	--	--	ns	
Data hold time	t_{dhd}	8	--	--	ns	

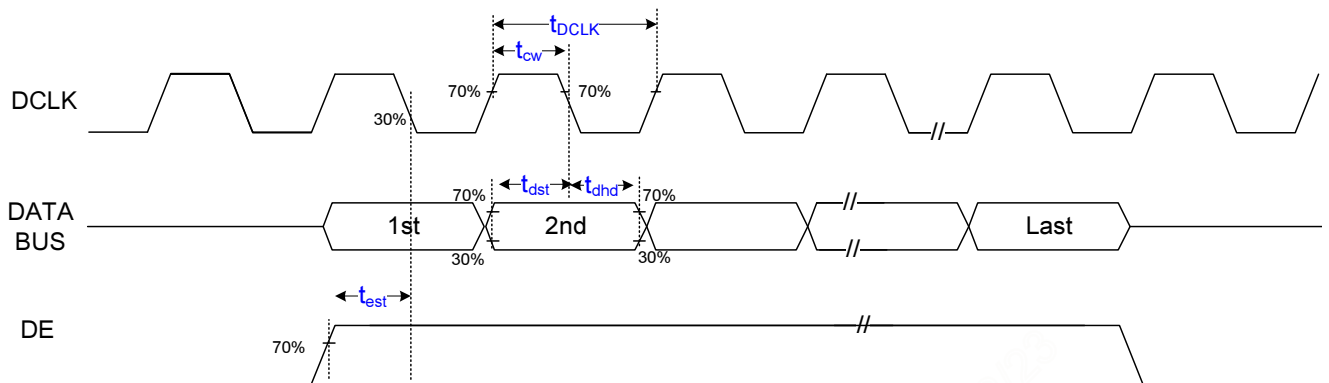

t_{DCLK} : DCLK period

t_{cw} : the width of DCLK high

b. Timing Diagram

1. Vertical Timing of Input

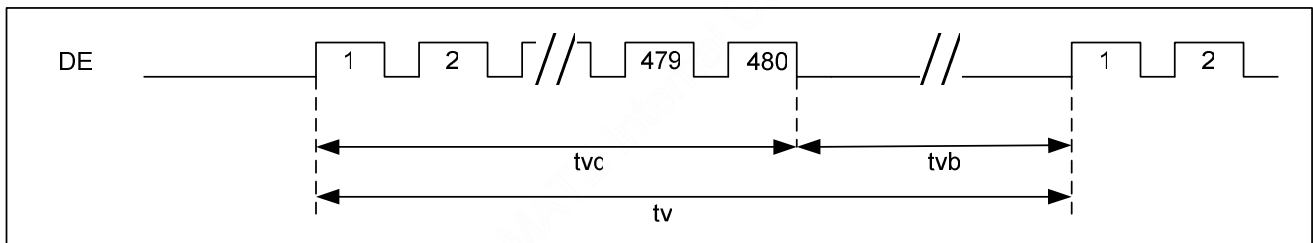

2. Horizontal Timing of Input

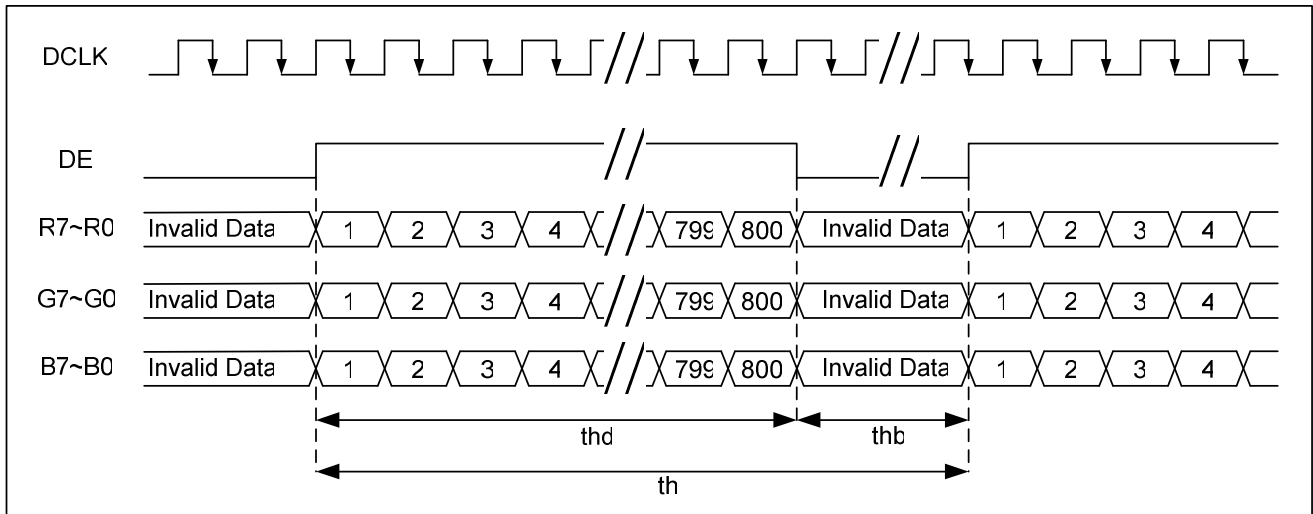

c. Timing Parameters

PARAMETER	Symbol	Min	Typ	Max	Unit
Clock cycle	$1/t_{DCLK}$	-	30	50	MHz
Horizontal cycle	$1/th$	-	32.33	-	KHz
Vertical cycle	$1/tv$	-	61.58	-	Hz
Horizontal Signal					
Horizontal cycle *1	th	880	928	1100	DCLK
Horizontal display period	thd	-	800	-	DCLK
Horizontal blank	thb	80	128	300	DCLK
Vertical Signal					
Vertical cycle	tv	500	525	680	H
Vertical display period	tvd	-	480	-	H
Vertical blank	tvb	20	45	200	H

5. Power On/Off Characteristics

a. Recommended Power On Sequence

The LCD adopts high voltage driver IC, so it could be permanently damaged under a wrong power on/off sequence. The suggested LCD power sequence is below:

Power on sequence: VDD→DCLK→DISP→LED UNIT.

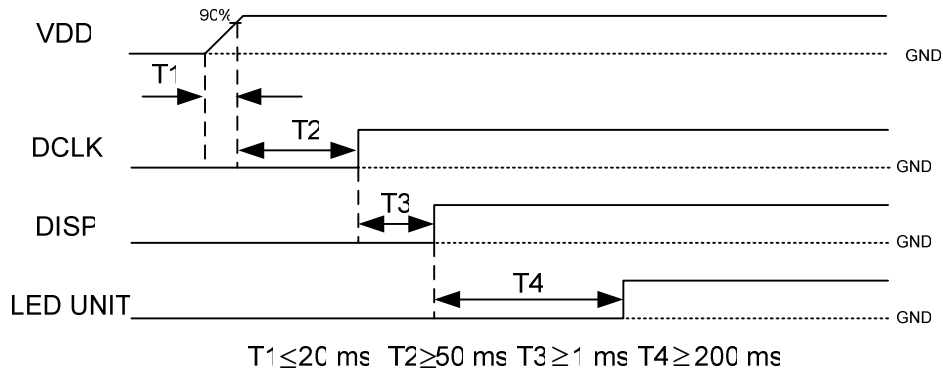

b. Recommended Power Off Sequence

Power off sequence: LED UNIT→DISP →DCLK→ VDD.

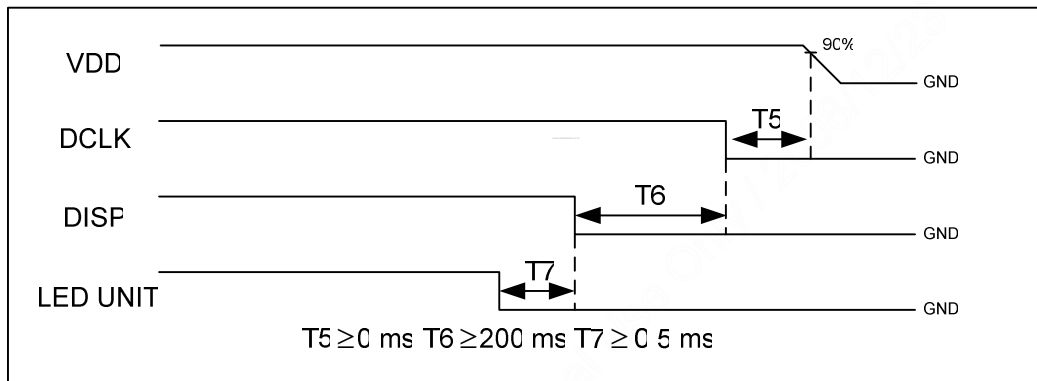

Signals DCLK, DISP and DE must be pulled low at power on. Any power on glitches at these signals can cause abnormal display. Below is an example of DE signal demonstrating a signal glitch power on and a correct signal power on.

D. Optical Specification

All optical specification is measured under typical condition (Note 1, 2)

Item	Symbol	Condition	Min.	Typ.	Max.	Unit	Remark
Response Time							
Rise	Tr	$\theta=0^\circ$	--	15	20	ms	Note 3
Fall	Tf	$\theta=0^\circ$	--	20	25	ms	
Contrast ratio	CR	At optimized viewing angle	250	300	--		Note 4
Viewing Angle							
Top		CR \square 10	--	45	--	deg.	Note 5
Bottom			--	55	--		
Left			--	60	--		
Right			--	60	--		
Brightness	Y_L	$\theta=0^\circ$	400	480	--	cd/m ²	Note 6
Chromaticity	White	X	$\theta=0^\circ$	0.26	0.31	0.36	
		Y	$\theta=0^\circ$	0.28	0.33	0.38	
	Red	X	$\theta=0^\circ$	0.585	0.635	0.685	
		Y	$\theta=0^\circ$	0.300	0.350	0.400	
	Green	X	$\theta=0^\circ$	0.285	0.335	0.385	
		Y	$\theta=0^\circ$	0.485	0.535	0.585	
	Blue	X	$\theta=0^\circ$	0.095	0.145	0.195	
		Y	$\theta=0^\circ$	0.050	0.100	0.150	
Uniformity	ΔY_L	%	70	75	--	%	Note 7

Note 1: Measured under Ambient temperature =25°C, and LED lightbar current $I_L = 20\text{mA}$ in the dark room.

Note 2: To be measured on the center area of panel with a viewing cone of 1° by Topcon luminance meter BM-5A, after 15 minutes operation.

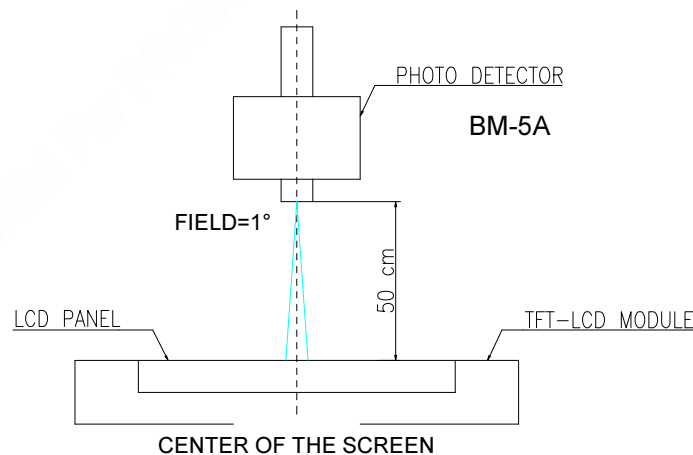

Note 3: Definition of response time:

The output signals of photo detector are measured when the input signals are changed from "black" to "white" (falling time) and from "white" to "black" (rising time), respectively.

The response time is defined as the time interval between the 10% and 90% of amplitudes. Refer to figure as below.

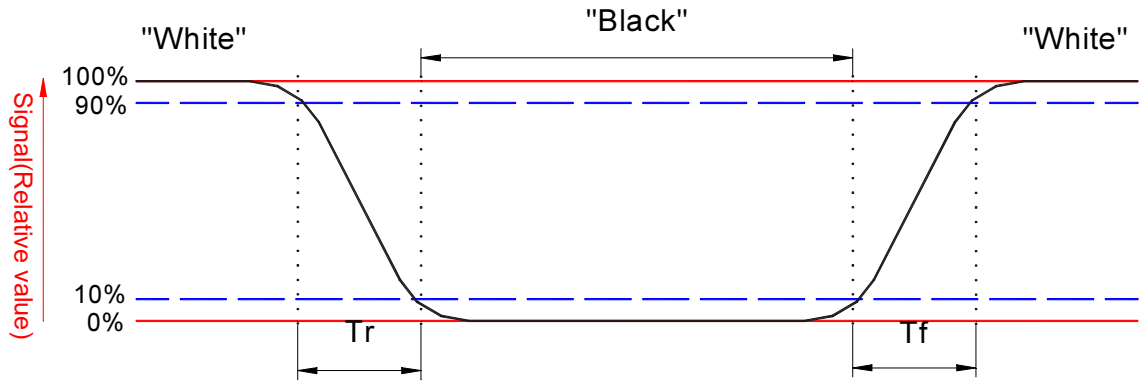

Note 4. Definition of contrast ratio:

Contrast ratio is calculated with the following formula.

$$\text{Contrast ratio (CR)} = \frac{\text{Photo detector output when LCD is at "White" status}}{\text{Photo detector output when LCD is at "Black" status}}$$

Note 5. Definition of viewing angle, θ , Refer to figure as below.

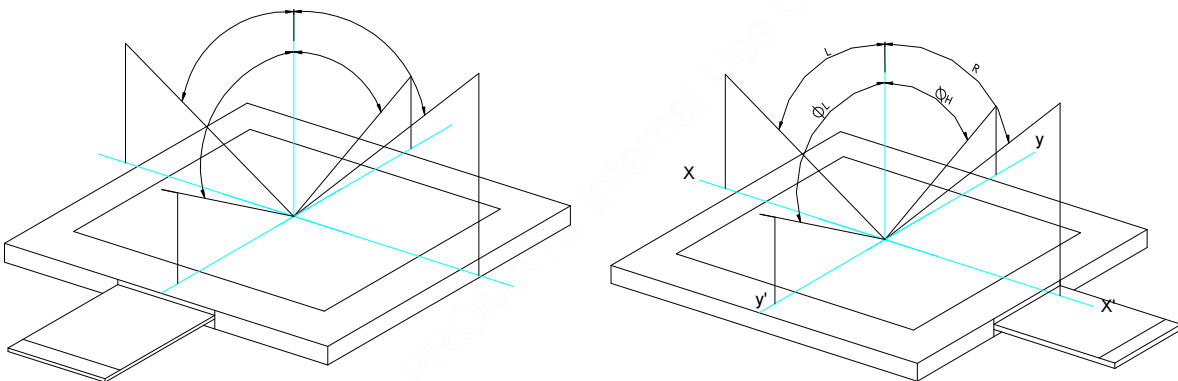

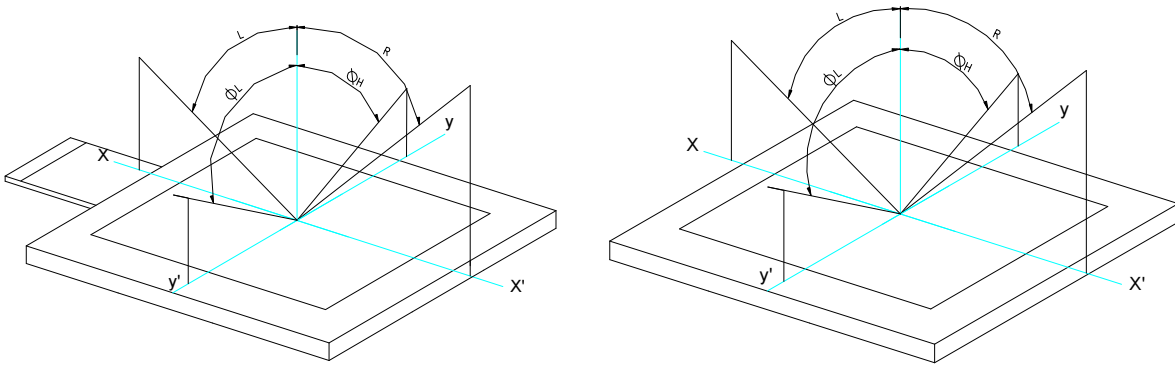

Note 6: Measured at the center area of the panel when all the input terminals of LCD panel are electrically opened.

Note 7: Luminance Uniformity of these 9 points is defined as below:

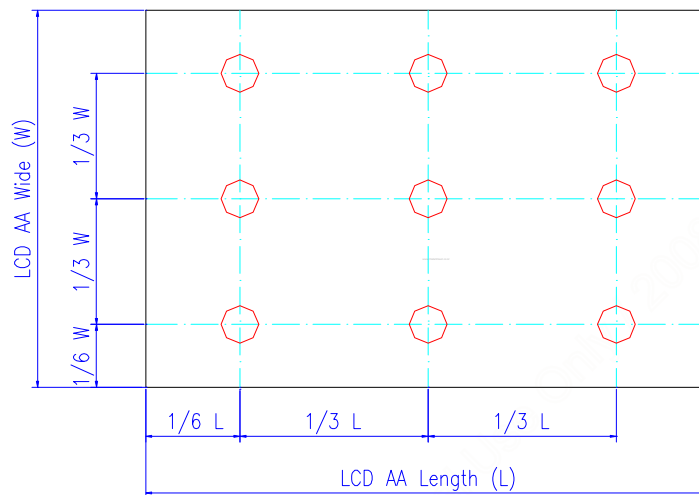

$$\text{Uniformity} = \frac{\text{minimum luminance in 9 points (1-9)}}{\text{maximum luminance in 9 points (1-9)}}$$

E. Reliability Test Items

No.	Test items	Conditions	Remark
1	High Temperature Storage	Ta= 80□ 240Hrs	
2	Low Temperature Storage	Ta= -30□ 240Hrs	
3	High Ttemperature Operation	Tp= 70□ 240Hrs	
4	Low Temperature Operation	Ta= -20□ 240Hrs	
5	High Temperature & High Humidity	Tp= 60□. 90% RH 240Hrs	Operation
6	Heat Shock	-25□~70□, 50 cycle, 2Hrs/cycle	Non-operation
7	Electrostatic Discharge	Contact = ± 4 kV, class B Air = ± 8 kV, class B	Note 5
8	Vibration	Frequency range : 10~55Hz Stoke : 1.5mm Sweep : 10Hz~55Hz~10Hz 2 hours for each direction of X,Y,Z 4 hours for Y direction	Non-operation JIS C7021, A-10 condition A : 15 minutes
9	Mechanical Shock	100G . 6ms, ±X,±Y,±Z 3 times for each direction	Non-operation JIS C7021, A-7 condition C
10	Vibration (With Carton)	Random vibration: 0.015G ² /Hz from 5~200Hz -6dB/Octave from 200~500Hz	IEC 68-34
11	Drop (With Carton)	Height: 60cm 1 corner, 3 edges, 6 surfaces	
12	Pressure	5kgf, 5sec	Note 6

Note 1: Ta: Ambient Temperature. Tp: Panel Surface Temperature

Note 2: In the standard conditions, there is not display function NG issue occurred. All the cosmetic specification is judged before the reliability stress.

Note 3: All the cosmetic specification is judged before the reliability stress.

Note 4: temperature and relative humidity range is shown in the figure below

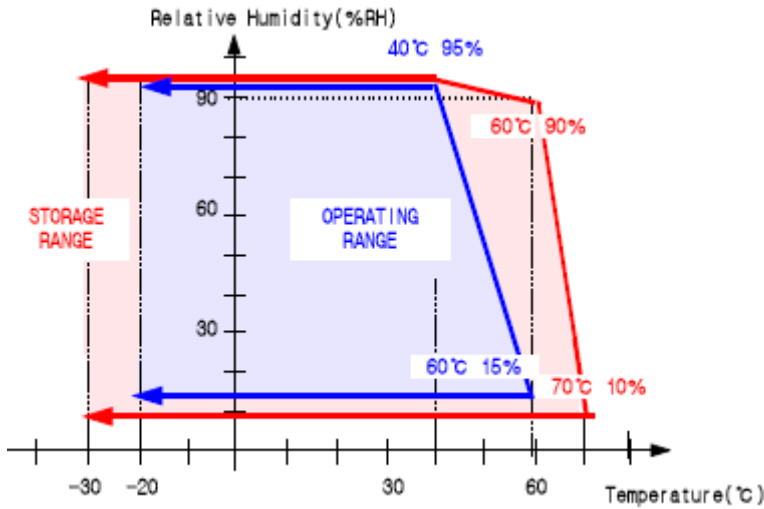

Note 5 : All test techniques follow IEC6100-4-2 standard.

Test Condition		Note
Pattern		
Procedure And Set-up	<p>Contact Discharge : 330Ω, 150pF, 1sec, 5 point, 10times/point Air Discharge : 330Ω, 150pF, 1sec, 5 point, 10times/point</p>	
Criteria	B – Some performance degradation allowed. No data lost. Self-recoverable hardware failure.	

Note 6: The panel is tested as figure. The jig is ϕ 10 mm made by Copper with rubber and the loading speed is 3mm/min on position A~E. After the condition, no glass crack will be found and panel

function check is OK.(no guarantee LC mura · LC bubble)

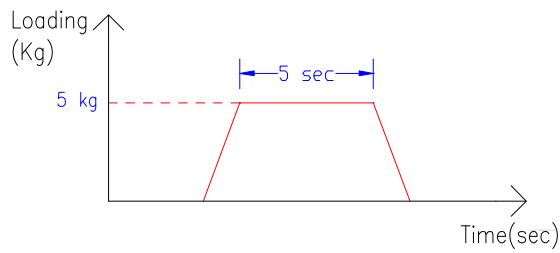
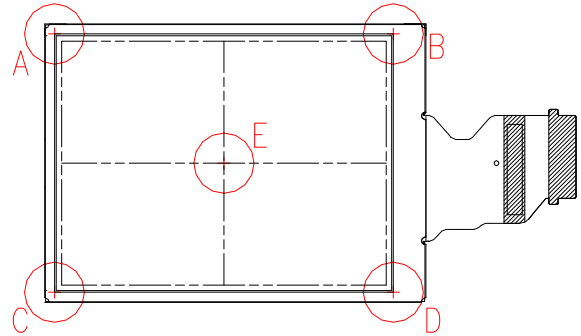
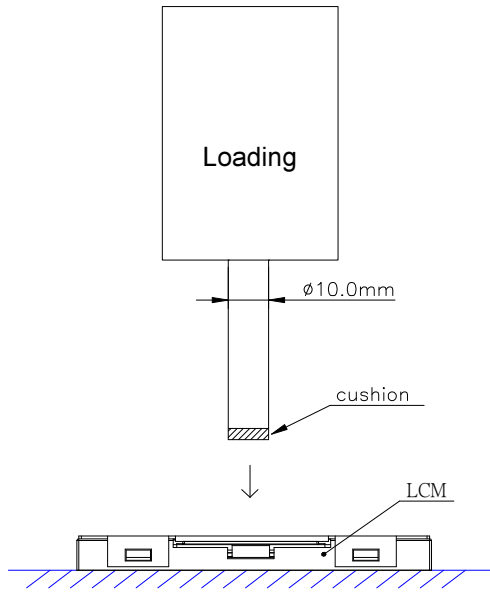

AUO Confidential For PROMOTE Internal Use Only (2007/12/18)

F. Packing and Marking

1. Packing Form

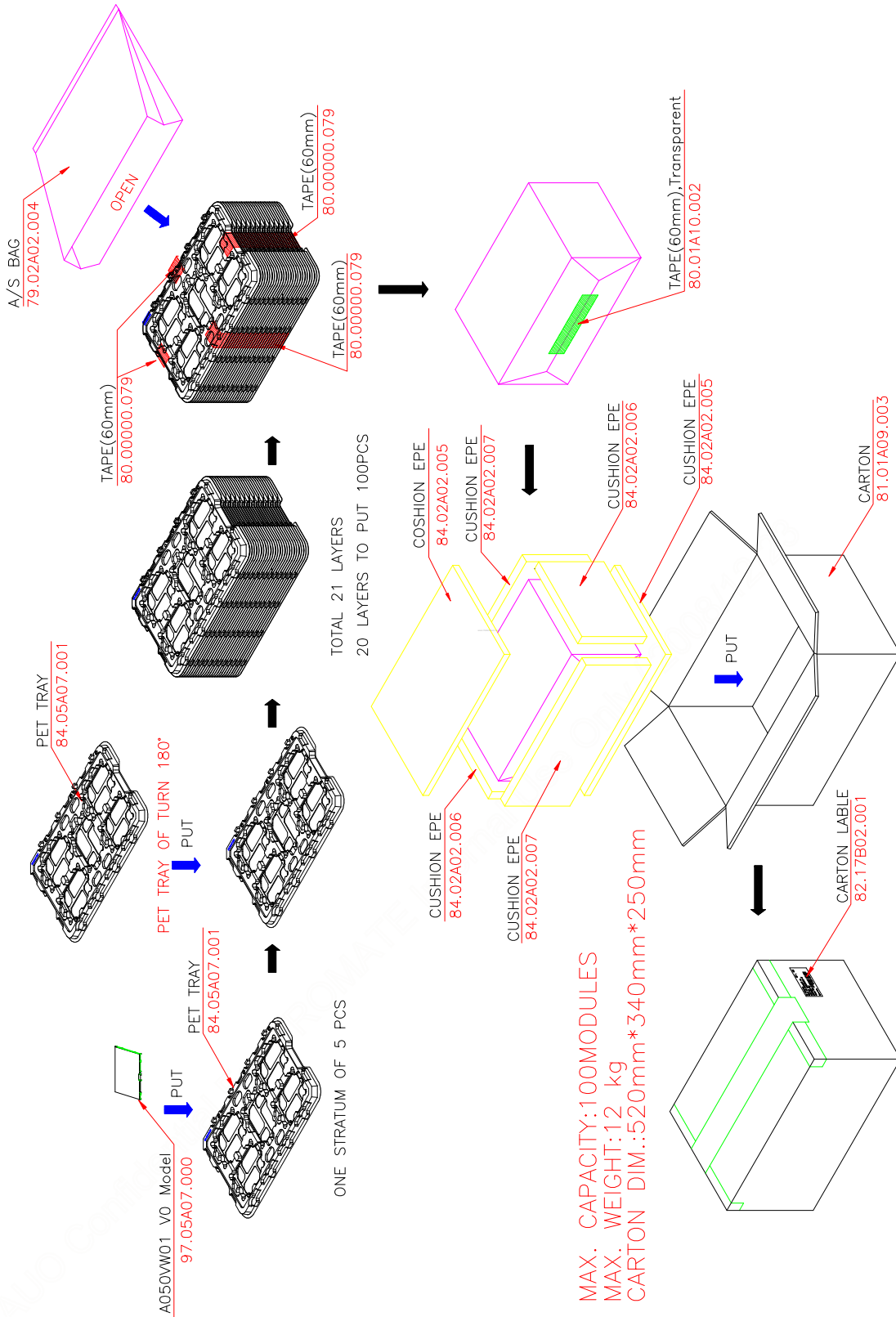

2. Module/Panel Label Information

The module/panel (collectively called as the "Product") will be attached with a label of Shipping Number which represents the identification of the Product at a specific location. Refer to the Product outline drawing for detailed location and size of the label. The label is composed of a 22-digit serial number with the following definition:

ABCDEFGHIJKLMNOPQRSTUV

- └─ For internal system usage and production serial numbers.
- └─ AUO Module or Panel factory code, represents the final production factory to complete the Product
- └─ Product version code, ranging from 0~9 or A~Z (for Version after 9)
- └─ Week Code, the production week when the product is finished at its production process

Example:

501M06ZL06123456781Z05:

Product Manufacturing Week Code: WK50

Product Version: Version 1

Product Manufacturing Factory: M06

3. Carton Label Information

The packing carton will be attached with a carton label where packing Q'ty, AUO Model Name, AUO Part Number, Customer Part Number (Optional) and a series of Carton Number in 13 or 14 digits are printed. The Carton Number is appearing in the following format:

ABC-DEFG-HIJK-LMN

- └─ DEFG appear after first "-" represents the packing date of the carton
- └─ Date from 01 to 31
- └─ Month, ranging from 1~9, A~C. A for Oct, B for Nov and C for Dec.
- └─ A.D. year, ranging from 1~9 and 0. The single digit code represents the last number of the year

Refer to the drawing of packing format for the location and size of the carton label.

G. Precautions

1. Do not twist or bend the module and prevent the unsuitable external force for display module during assembly.
2. Adopt measures for good heat radiation. Be sure to use the module with in the specified temperature.
3. Avoid dust or oil mist during assembly.
4. Follow the correct power sequence while operating. Do not apply the invalid signal, otherwise, it will cause improper shut down and damage the module.
5. Less EMI: it will be more safety and less noise.
6. Please operate module in suitable temperature. The response time & brightness will drift by different temperature.
7. Avoid to display the fixed pattern (exclude the white pattern) in a long period, otherwise, it will cause image sticking.
8. Be sure to turn off the power when connecting or disconnecting the circuit.
9. Polarizer scratches easily, please handle it carefully.
10. Display surface never likes dirt or stains.
11. A dewdrop may lead to destruction. Please wipe off any moisture before using module.
12. Sudden temperature changes cause condensation, and it will cause polarizer damaged.
13. High temperature and humidity may degrade performance. Please do not expose the module to the direct sunlight and so on.
14. Acetic acid or chlorine compounds are not friends with TFT display module.
15. Static electricity will damage the module, please do not touch the module without any grounded device.
16. Do not disassemble and reassemble the module by self.
17. Be careful do not touch the rear side directly.
18. No strong vibration or shock. It will cause module broken.
19. Storage the modules in suitable environment with regular packing.
20. Be careful of injury from a broken display module.
21. Please avoid the pressure adding to the surface (front or rear side) of modules, because it will cause the display non-uniformity or other function issue.