

Product Specifications

5.6" color TFT-LCD module

MODEL NAME: A056DN01 V6

(◆) Preliminary Specification

(.....) Final Specification

Note: The content of this specification is subject to change.

© 2006 AU Optronics Corp.
All Rights Reserved

Table of Contents

A. Physical specifications.....	4
B. Electrical specifications	5
1. Pin assignment.....	5
a. TFT-LCD panel driving section	5
b. Backlight driving section (Refer to Figure 1)	6
2. Absolute maximum ratings	6
3. Electrical characteristics	7
a. Typical operating conditions (GND=AV _{ss} =0V, Note 3).....	7
b. Current consumption (GND=AV _{ss} =0V)	8
c. Backlight driving conditions.....	8
4. AC Timing.....	8
a. Timing conditions	8
b. Timing diagram.....	9
5. Power Sequence.....	9
C. Optical specification (Note 1, Note 2).....	11
D. Reliability test items (Note 2):.....	13
E. Packing form	14

A. Physical specifications

NO.	Item	Specification	Remark
1	Display resolution (dot)	960 (W) X 234 (H)	
2	Active area (mm)	113.3 (W) X 84.7 (H)	
3	Screen size (inch)	5.6 (Diagonal)	
4	Dot pitch (mm)	0.118 (W) X 0.362 (H)	
5	Color configuration	R. G. B. stripe	
6	Overall dimension (mm)	126.5 (W) X 100 (H) X 5.1 (D)	Note 1
7	Weight (g)	TBD	

Note 1: Refer to Fig. 1

B. Electrical specifications

1. Pin assignment

a. TFT-LCD panel driving section

Pin No.	Symbol	I/O	Description	Remark
1	GND	-	Ground for logic circuit	
2	V _{CC}	I	Supply voltage of logic control circuit for scan driver	
3	V _{GL}	I	Negative power for scan driver	
4	V _{GH}	I	Positive power for scan driver	
5	STVR	I/O	Vertical start pulse	Note 1
6	STVL	I/O	Vertical start pulse	Note 1
7	CKV	I	Shift clock input for scan driver	
8	U/D	I	UP/DOWN scan control input	Note 1, 2
9	OEV	I	Output enable input for scan driver	
10	VCOM	I	Common electrode driving signal	
11	VCOM	I	Common electrode driving signal	
12	L/R	I	LEFT/RIGHT scan control input	Note 1, 2
13	MOD	I	Sequential sampling and simultaneous sampling setting	Note 3
14	OEH	I	Output enable input for data driver	
15	STHL	I/O	Start pulse for horizontal scan line	Note 1
16	STHR	I/O	Start pulse for horizontal scan line	Note 1
17	CPH3	I	Sampling and shifting clock pulse for data driver	
18	CPH2	I	Sampling and shifting clock pulse for data driver	
19	CPH1	I	Sampling and shifting clock pulse for data driver	
20	V _{CC}	I	Supply voltage of logic control circuit for data driver	
21	GND	-	Ground for logic circuit	
22	VR	I	Alternated video signal input (Red)	
23	VG	I	Alternated video signal input (Green)	
24	VB	I	Alternated video signal input (Blue)	
25	AV _{DD}	I	Supply voltage for analog circuit	
26	AV _{SS}	-	Ground for analog circuit	

Note 1: Selection of scanning mode (please refer to the following table)

Setting of scan Control input		IN/OUT state For start pulse				Scanning direction
U/D	L/R	STVR	STVL	STHR	STHL	
GND	V _{CC}	OUT	IN	OUT	IN	From up to down, and from left to right.
V _{CC}	GND	IN	OUT	IN	OUT	From down to up, and from right to left.
GND	GND	OUT	IN	IN	OUT	From up to down, and from right to left.
V _{CC}	V _{CC}	IN	OUT	OUT	IN	From down to up, and from left to right.

IN: Input; OUT: Output.

Note 2: Definition of scanning direction.

Refer to the figure as below:

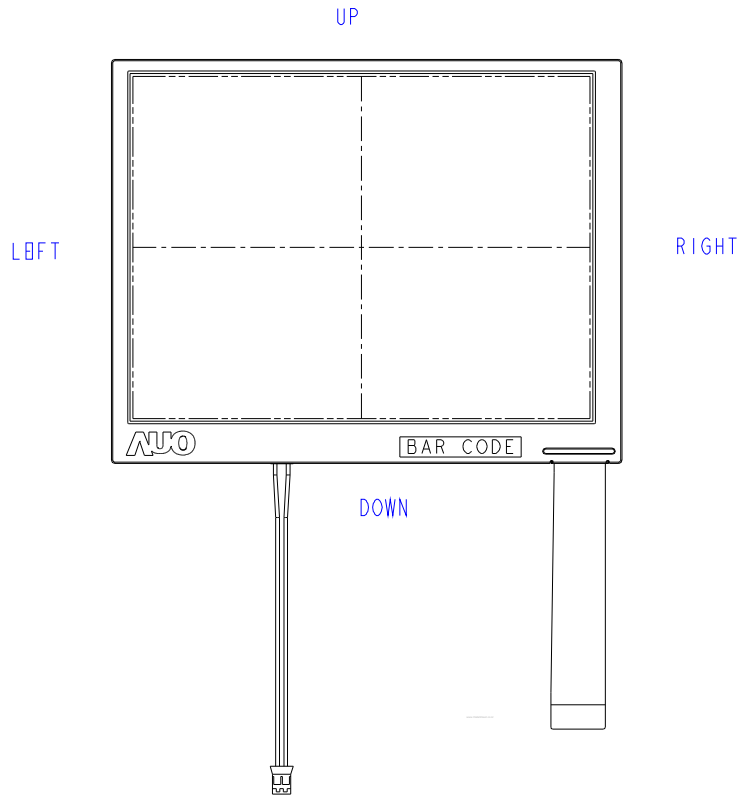

Note 3: MOD = H: Simultaneous sampling.

MOD = L: Sequential sampling.

Please set CPH2 and CPH3 to GND when MOD = H.

b. Backlight driving section (Refer to Figure 1)

No.	Symbol	I/O	Description	Remark
1	HI	I	Power supply for backlight unit (Constant Current)	--
2	GND	-	Ground for backlight unit	--

2. Absolute maximum ratings

Item	Symbol	Condition	Min.	Max.	Unit	Remark
	V_{CC}	GND=0	-0.3	5	V	
	AV_{DD}	$AV_{SS}=0$	-0.3	7	V	
	V_{GH}	GND=0	-0.3	18	V	
	V_{GL}		-15	0.3	V	

	$V_{GH} - V_{GL}$		-	33	V	
Input signal voltage	V_i		-0.3	$AV_{DD}+0.3$	V	Note 1
	V_i		-0.3	$V_{CC}+0.3$	V	Note 2
	VCOM		-2.9	5.2	V	
Storage Temperature	Tstg		-25	+80	□	Note 3
Operation Temperature	Top	Surface	-10	+60	□	Note 3,4,5
LED Max. Rating Current	I_{LED}			220	mA	

Note 1: VR, VG, VB.

Note 2: STHL, STHR, OEH, L/R, CPH1~CPH3, STVR, STVL, OEV, CKV, and U/D.

Note 3: The temperature of panel surface must not exceed this rating

Note 4: Maximum wet-bulb temperature must be less than 58□. No dew condensation.

Note 5: The operating temperature assures only driving. Contrast, response time, the other display quality is judgment at 25□.

3. Electrical characteristics

The following items are measured under stable condition and suggested application circuit.

a. Typical operating conditions (GND=AVss=0V, Note 3)

Item		Symbol	Min.	Typ.	Max.	Unit	Remark
Power supply	VCC		3.0	3.3	3.6	V	
	AVDD		5.0	5.25	5.5	V	
	VGH		14.3	15	15.7	V	
	VGL		-10.5	-10	-9.5	V	
Input Signal voltage	H Level	V_{IH}	$0.8 V_{CC}$	-	V_{CC}	V	Note 2
	L Level	V_{IL}	0	-	$0.2 V_{CC}$	V	
Video signal amplitude (VR, VG, VB)	V_{iA}		0.4	-	$AV_{DD}-0.4$	V	Note 1
	V_{iAC}		-	3	-	V	AC component
	V_{iDC}		-	$AV_{DD}/2$	-	v	DC component
Analog stand by current	I_{st}		-	-	200	uA	DCLK is stopped
VCOM	V_{CAC}		3.5	5.6	6.5	Vp-p	AC component
	V_{CDC}		1.4	1.7	2.0	V	DC component

Note 1: Refer to Fig. 4- (a).

Note 2: STHL, STHR, OEH, L/R, CPH1~CPH3, STVR, STVL, OEV, CKV, U/D.

Note 3: Be sure to apply GND, V_{CC} and V_{GL} to the LCD first, and then apply V_{GH} .

b. Current consumption (GND=AVss=0V)

Parameter	Symbol	Condition	Min.	Typ.	Max.	Unit	Remark
Current for driver	I_{GH}	$V_{GH}=15V$	-	0.20	0.5	mA	
	I_{GL}	$V_{GL}=-10V$	-	0.80	1.5	mA	
	I_{CC}	$V_{CC}=5V$	-	3.0	6.0	mA	
	I_{DD}	$AV_{DD}=5V$	-	17.0	30	mA	

c. Backlight driving conditions

Parameter	Symbol	Min.	Typ.	Max.	Unit	Remark
LED Current	I_L	---	175	185	mA	---
LED Voltage	V_L	5.6	6.6	7.6	V	---
LED Life Time	L_L	10,000	---	---	Hr	Note 2, 3

Note 1: LED backlight is two LEDs serial type.

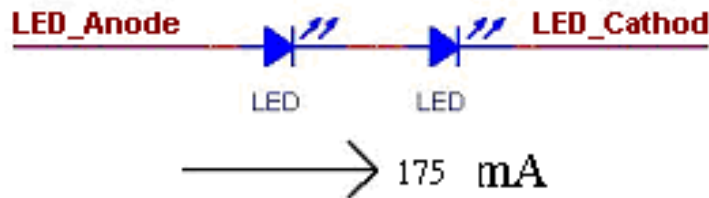

Note 2: Define “LED Lifetime”: brightness is decreased to 50% of the initial value. LED Lifetime is restricted under normal condition, ambient temperature = 25°C and LED current = 175mA.

Note 3: If it uses larger LED current I_L more than 175mA, it maybe decreases the LED lifetime.

4. AC Timing

a. Timing conditions

Parameter	Symbol	Min.	Typ.	Max.	Unit.	Remark
Rising time	t_r	-	-	10	ns	Note 1
Falling time	t_f	-	-	10	ns	Note 1
High and low level pulse width	t_{CPH}	99	103	107	ns	CPH1~CPH3
CPH pulse duty	t_{CWH}	40	50	60	%	CPH1~CPH3
CPH pulse delay	t_{C12} t_{C23} t_{C31}	30	$t_{CPH}/3$	$t_{CPH}/2$	ns	CPH1~CPH3
STH setup time	t_{SUH}	20	-	-	ns	STHR,STHL
STH hold time	t_{HDH}	20	-	-	Ns	STHR,STHL
STH pulse width	t_{STH}	-	1	-	t_{CPH}	STHR,STHL
STH period	t_H	61.5	63.5	65.5	μs	STHR,STHL
OEH pulse width	t_{OEH}	-	1.22	-	μs	OEH

OEV pulse width	t_{OEV}	-	5.40	-	μs	OEV
CKV pulse width	t_{CKV}	-	4.18	-	μs	CKV
Clean enable time	t_{DIS2}	-	3.74	-	μs	
Horizontal display start	t_{SH}	-	0	-	$T_{CPH}/3$	
Horizontal display timing range	t_{DH}	-	1440	-	$T_{CPH}/3$	
STV setup time	t_{SUV}	400	-	-	ns	STVL,STVR
STV hold time	t_{HDV}	400	-	-	ns	STVL,STVR
STV pulse width	t_{STV}	-	-	1	t_H	STVL,STVR
Horizontal lines per field	t_V	256	262	268	t_H	Note 2
Vertical display start	t_{SV}		3	-	t_H	
Vertical display timing range	t_{DV}		234	-	t_H	
VCOM rising time	t_{rCOM}		-	5	μs	
VCOM falling time	t_{fCOM}		-	5	μs	
VCOM delay time	t_{DCOM}		-	3	μs	
RGB delay time	t_{DRGB}		-	1	μs	

Note 1: For all of the logic signals.

Note 2: Please don't use odd horizontal lines to drive LCD panel for both odd and even field Simultaneously.

b. Timing diagram

Please refer to the attached drawing, from Fig.2 to Fig.6.

5. Power Sequence

Sequence for power on/off and Signal on/off

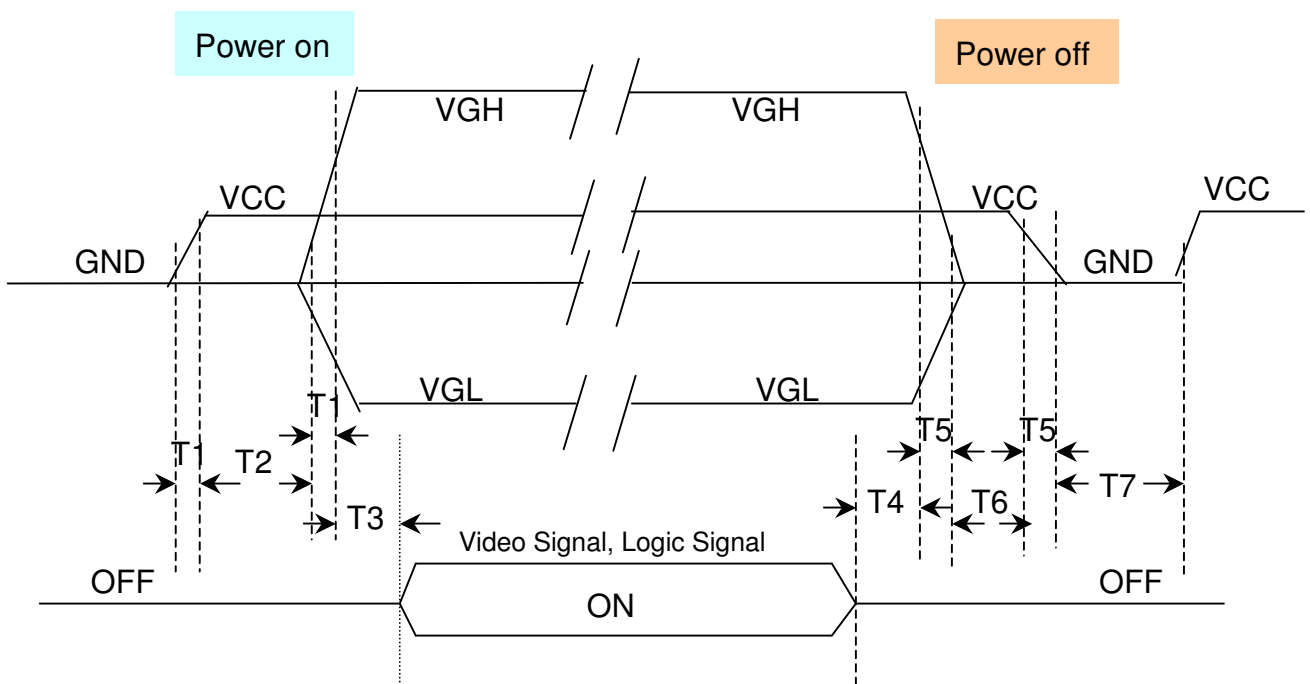

- T2 □ 10ms (From 90%*VCC to 10%*VGH , when VCC is Low to High) ;
- T3 □ 10ms (From 90%*VGH to Video signal , when VGH is Low to High) ;
- T4 □ 10ms (From Video signal to 90%*VGH , when VGH is High to Low) ;
- T5 □ 20ms (From 90%*VCC to 10%*VCC , when VCC is High to Low) ;
- T6 □ 10ms (From 10%*VGH to 90%*VCC , when VCC is Low to High) ;
- T7 □ 0.4s (From 10%*VCC is H→L to 10%*VCC is L→H) 。

C. Optical specification (Note 1, Note 2)

Item		Symbol	Condition	Min.	Typ.	Max.	Unit	Remark
Response time	Rise	Tr	$\theta=0^\circ$	-	12	24	ms	Note 3,5
	Fall	Tf		-	18	36	ms	
Contrast ratio		CR	At optimized Viewing angle	200	300	-		Note 4, 5
Viewing angle	Top		CR \square 10	30	45	-	deg.	Note 5, 6
	Bottom			50	65	-		
	Left			50	65	-		
	Right			50	65	-		
Brightness		Y_L	$I_L=175\text{mA}, 25^\circ$	250	300	-	cd/m^2	Note 7
White chromaticity		X	$\theta=0^\circ$	0.26	0.31	0.36		Note 7
		Y	$\theta=0^\circ$	0.29	0.34	0.39		

Note 1 : Ambient temperature =25 \square , and led current $I_L = 175 \text{ mArms}$. To be measured in the dark room.

Note 2 :To be measured on the center area of panel with a viewing cone of 1 ϕ by Topcon luminance meter BM-5, after 15 minutes operation.

Note 3: Definition of response time:

The output signals of photo detector are measured when the input signals are changed from "black" to "white"(falling time) and from "white" to "black"(rising time), respectively.

The response time is defined as the time interval between the 10% and 90% of amplitudes. Refer to figure as below.

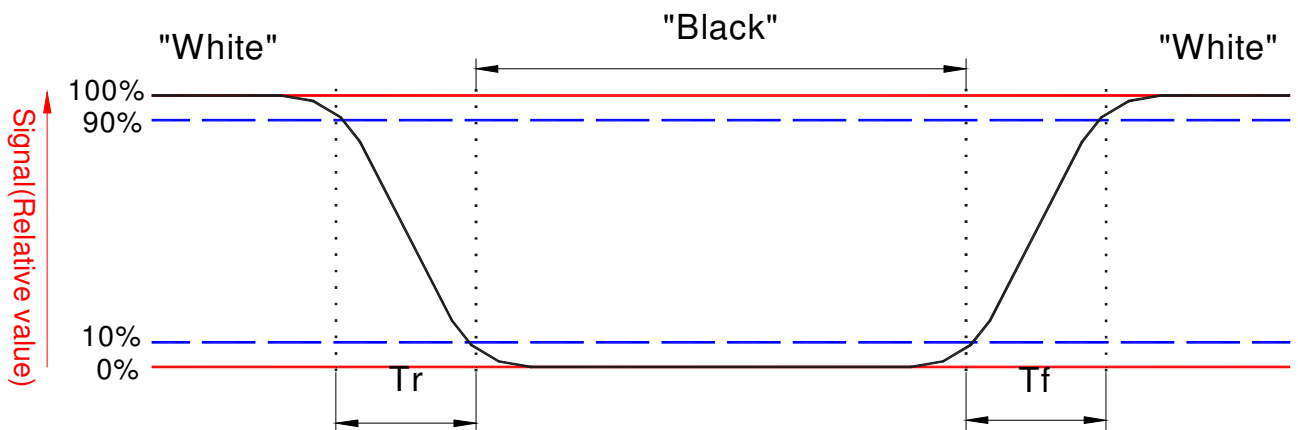

Note 4: Definition of contrast ratio:

Contrast ratio is calculated with the following formula.

$$\text{Contrast ratio (CR)} = \frac{\text{Photo detector output when LCD is at "White" state}}{\text{Photo detector output when LCD is at "Black" state}}$$

Note 5. White $V_i=V_{i50} + 1.5\text{V}$

Black $V_i=V_{i50} \pm 2.0\text{V}$

“±” means that the analog input signal swings in phase with V_{COM} signal.

“ \mp ” means that the analog input signal swings out of phase with V_{COM} signal.

V_{i50} : The analog input voltage when transmission is 50%

The 100% transmission is defined as the transmission of LCD panel when all the input terminals of module are electrically opened.

Note 6: Definition of viewing angle, Refer to figure as below.

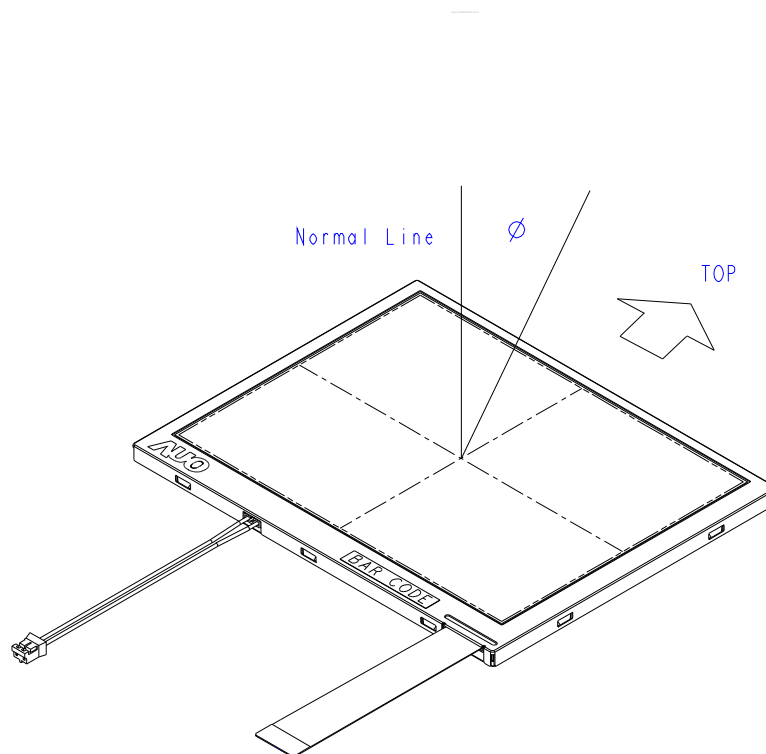

Note 7: Measured at the center area of the panel when all the input terminals of LCD panel are electrically opened.

D. Reliability test items (Note 2):

No.	Test items	Conditions	Remark
1	High temperature storage	Ta= 70□ 240Hrs	
2	Low temperature storage	Ta= -20□ 240Hrs	
3	High temperature operation	Tp= 60□ 240Hrs	
4	Low temperature operation	Ta= -10□ 240Hrs	
5	High temperature and high humidity	Tp= 40□, 90% RH 240Hrs	Operation
6	Heat shock	-10□~60□/100 cycles 1Hrs/cycle	Non-operation
7	Electrostatic discharge	±200V,200pF(0Ω), once for each terminal	Non-operation
8	Vibration	Frequency range : 8~33.3Hz Stoke : 1.3mm Sweep : 2.9G, 33.3 ~ 400Hz Cycle : 15 minutes 2 hours for each direction of X,Z 4 hours for Y direction	JIS C7021, A-10 Condition A
9	Mechanical shock	100G, 6ms, ±X,±Y,±Z 3 times for each direction	JIS C7021, A-7 Condition C
10	Vibration (with carton)	Random vibration: 0.015G ² /Hz from 5~200Hz -6dB/octave from 200~500Hz	IEC 68-34
11	Drop (with carton)	Height: 60cm 1 corner, 3 edges, 6 surfaces	JIS Z0202

Note1: Ta: Ambient temperature.

Note2: Tp: Panel Surface Temperature

Note3: In the standard conditions, there is not display function NG issue occurred. All the cosmetic specification is judged before the reliability stress.

E. Packing form

No.	Part Name	Part No.
1	A/S BAG 056A	79.05A02.001
2	S291 TAPE	84.01A04.001
3	TAPE 18MM(W) L133x1	80.13B01.011
4	CUSHION PACKAGING	83.05A03.002
5	CARTON AB DRG 520*340*250	81.01A09.003
6	CARTON BLANK LABEL	82.17B02.001

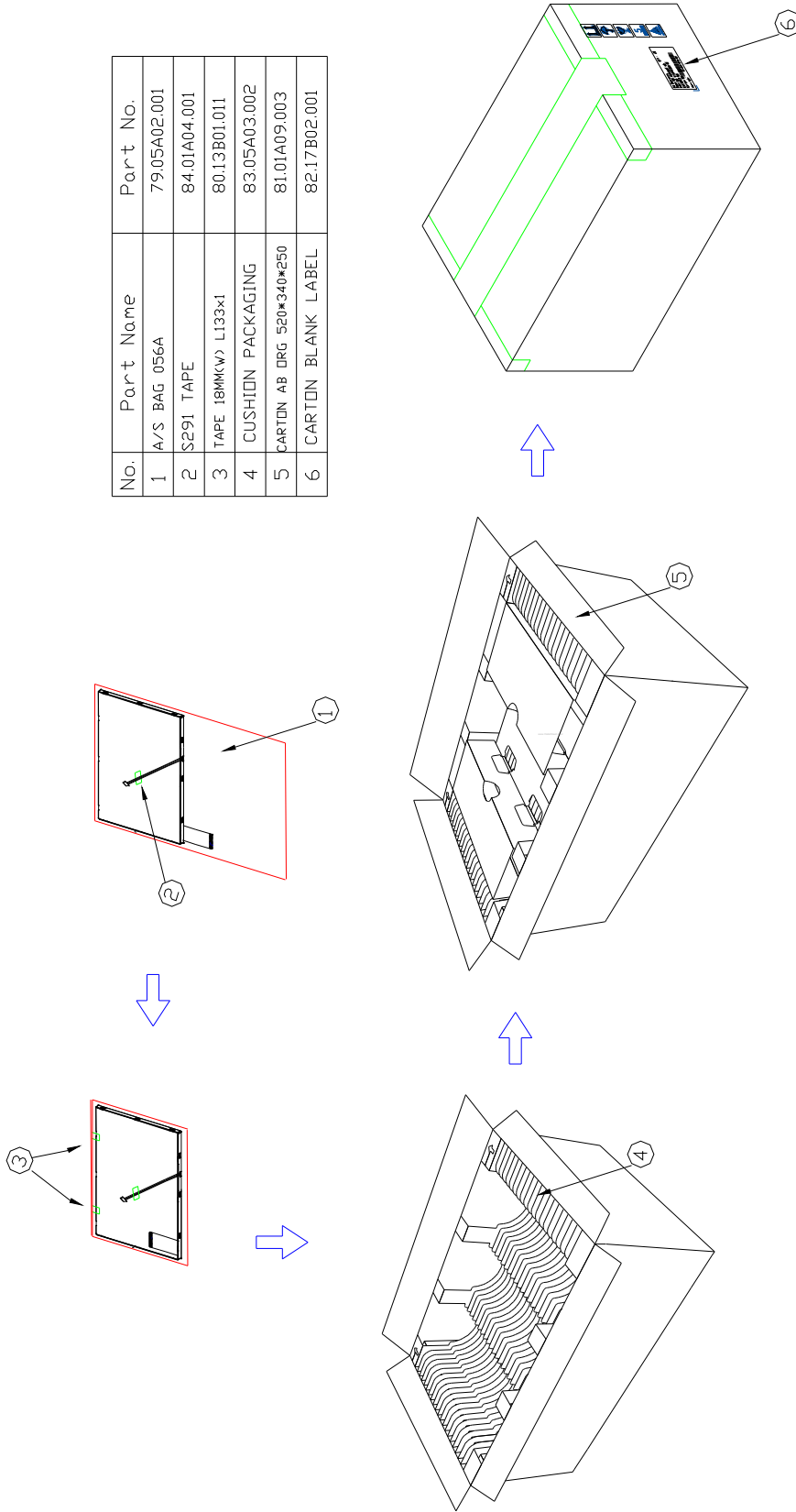

Max. capacity: 60 modules
 Max. Weight : 10kg
 Carton outline : 520 x 340 x 250 mm

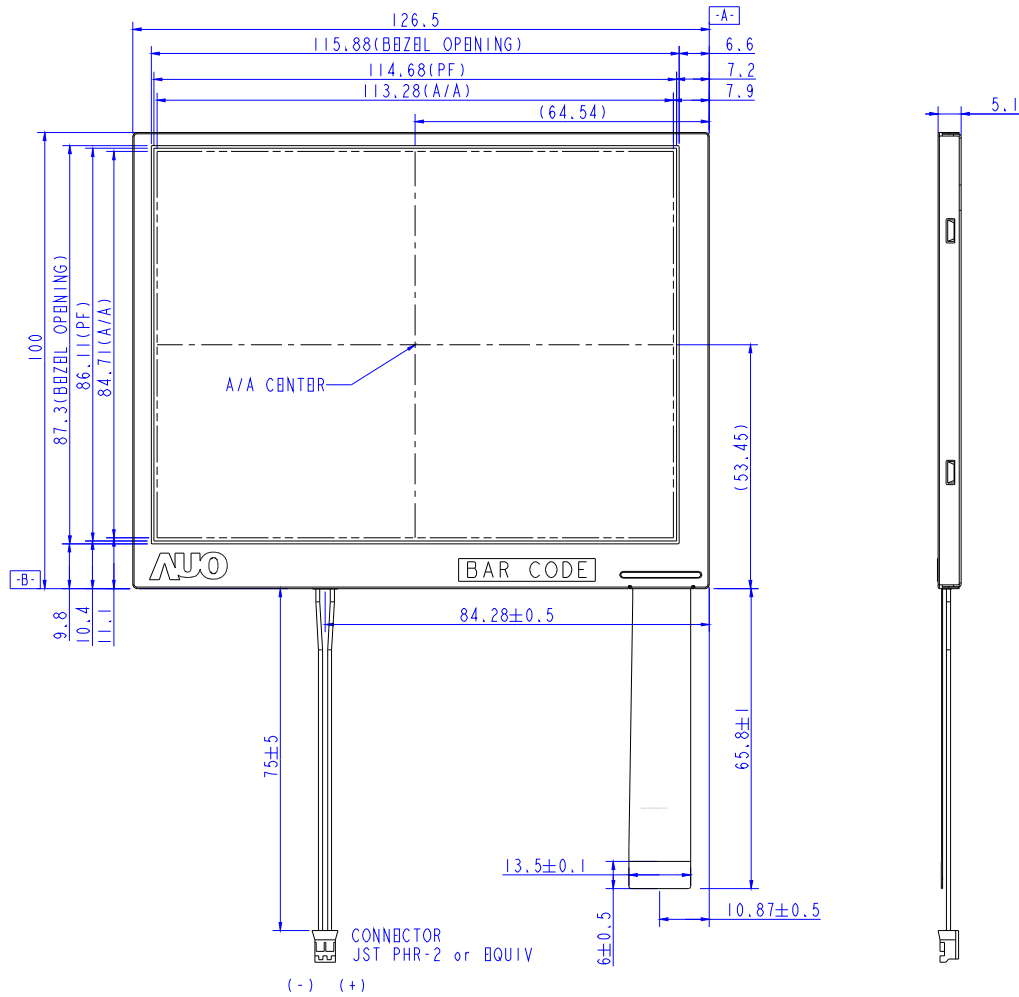

- NOTES:
1. UNIT: mm
 2. GENERAL TOLERANCE: ±0.3
 3. THE BENDING RADIUS OF FPC SHOULD BE LARGER THAN 0.6 mm

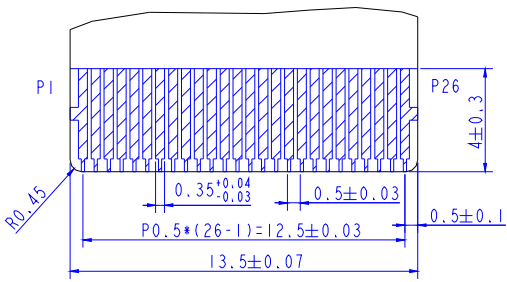

DBTAIL A
SCALE 5/1

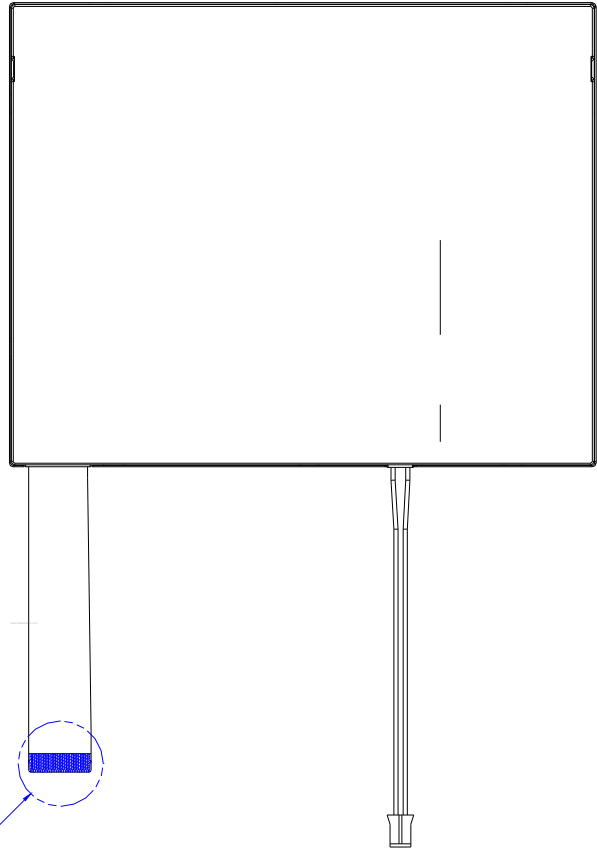
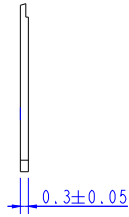

SBB DBTAIL A

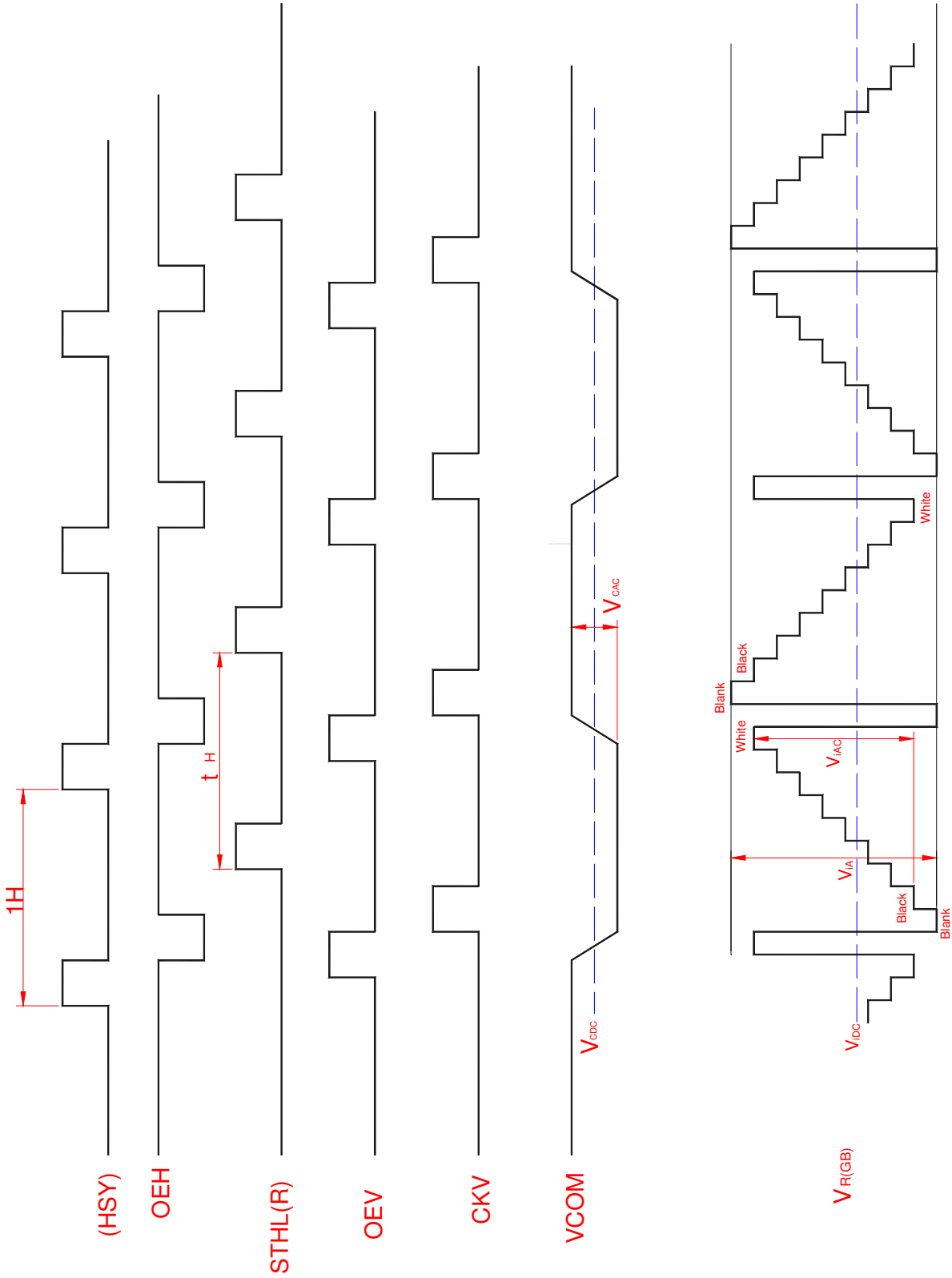
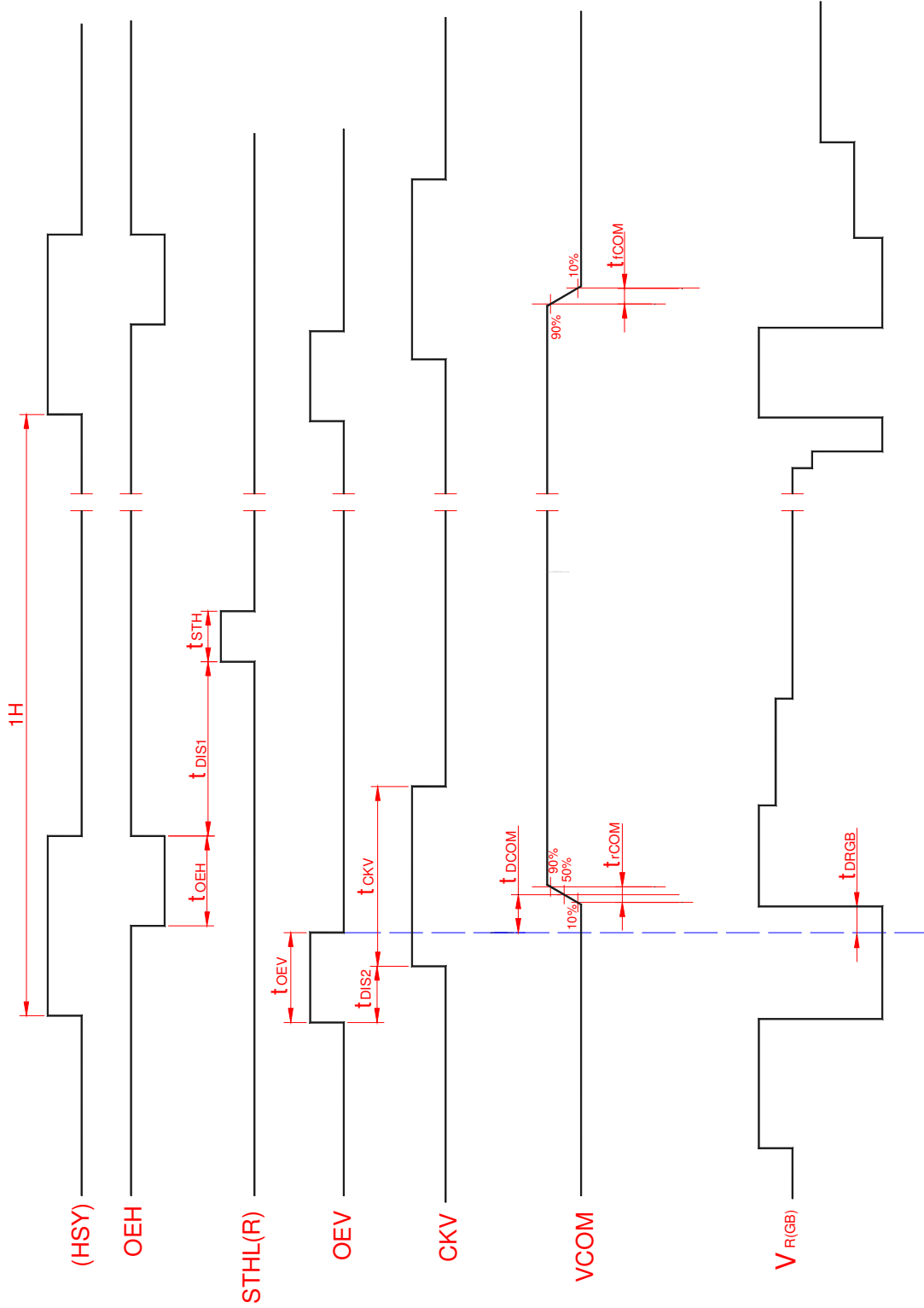

Fig. 4-(a) Horizontal timing



Note: The falling edge of OEV should be synchronized with the falling edge of OEH

Fig. 4-(b) Detail horizontal timing

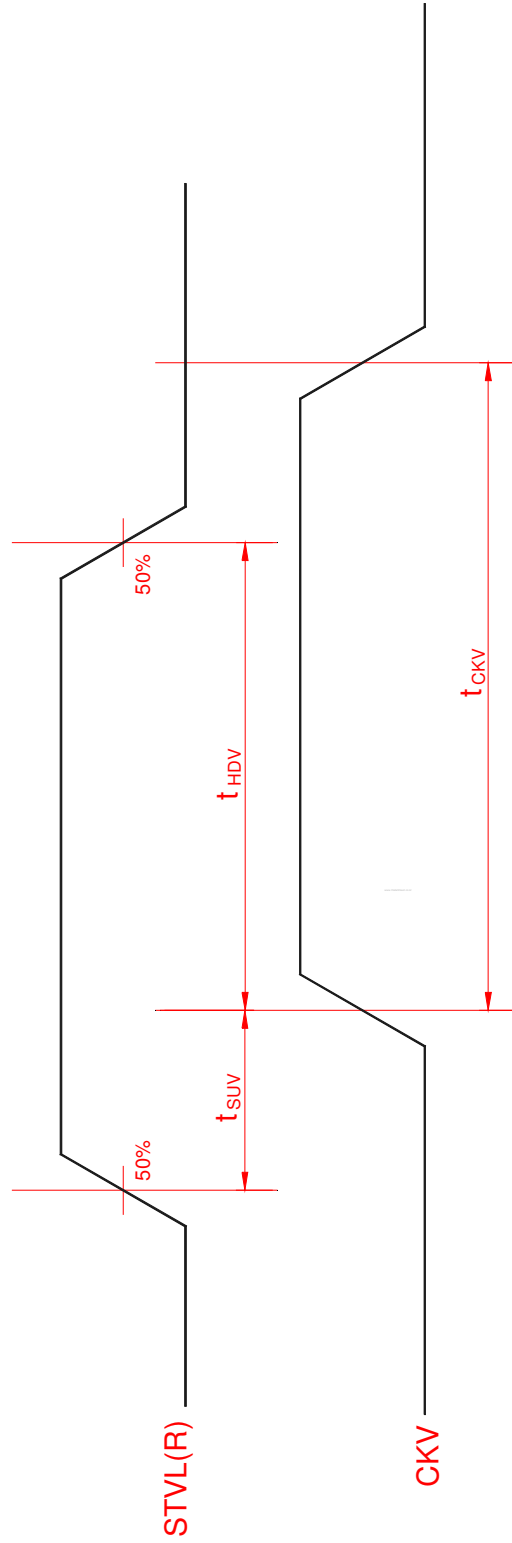

Fig. 5 Vertical shift clock timing

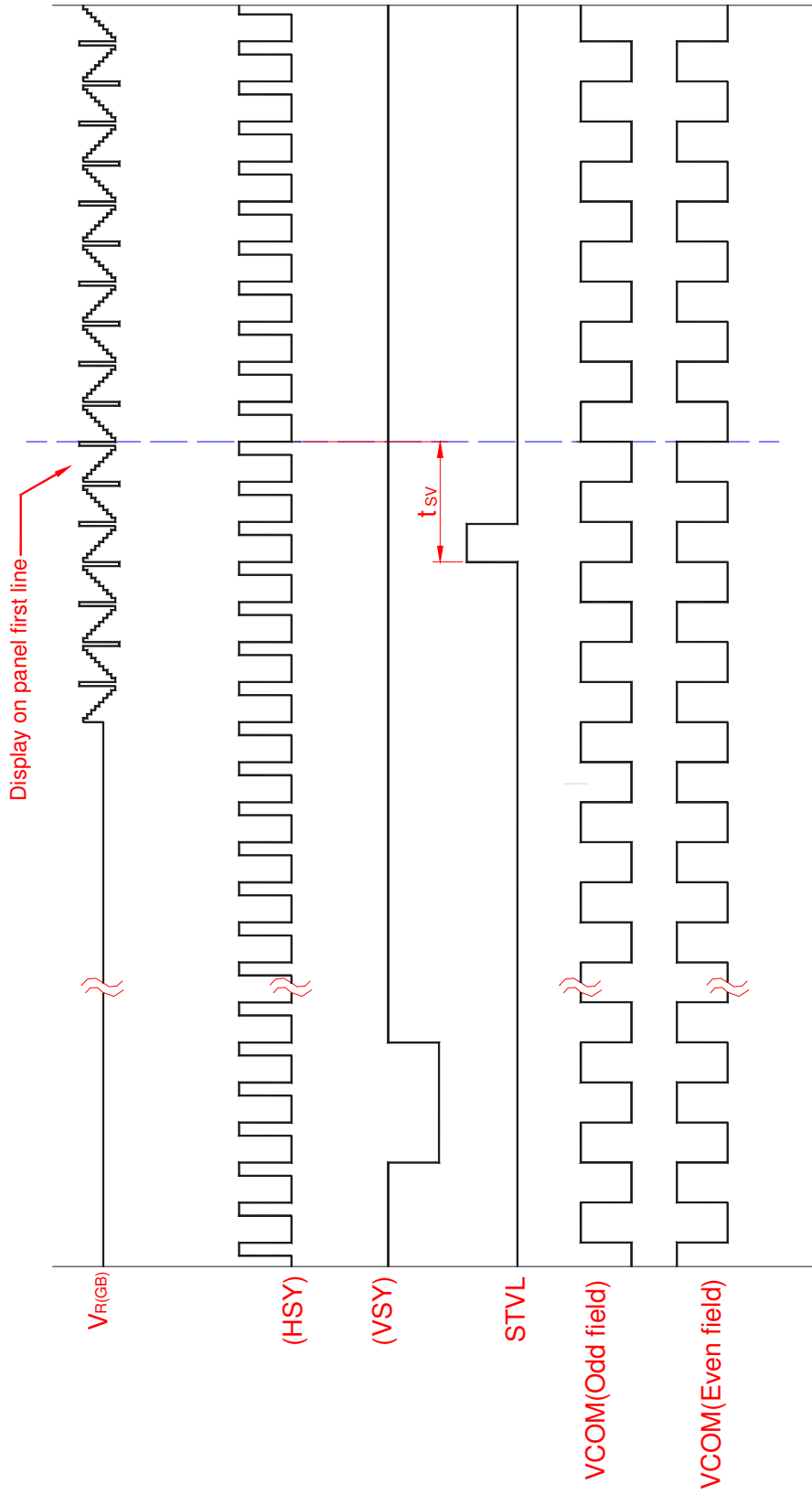

Fig. 6-(a) Vertical timing (From up to down)

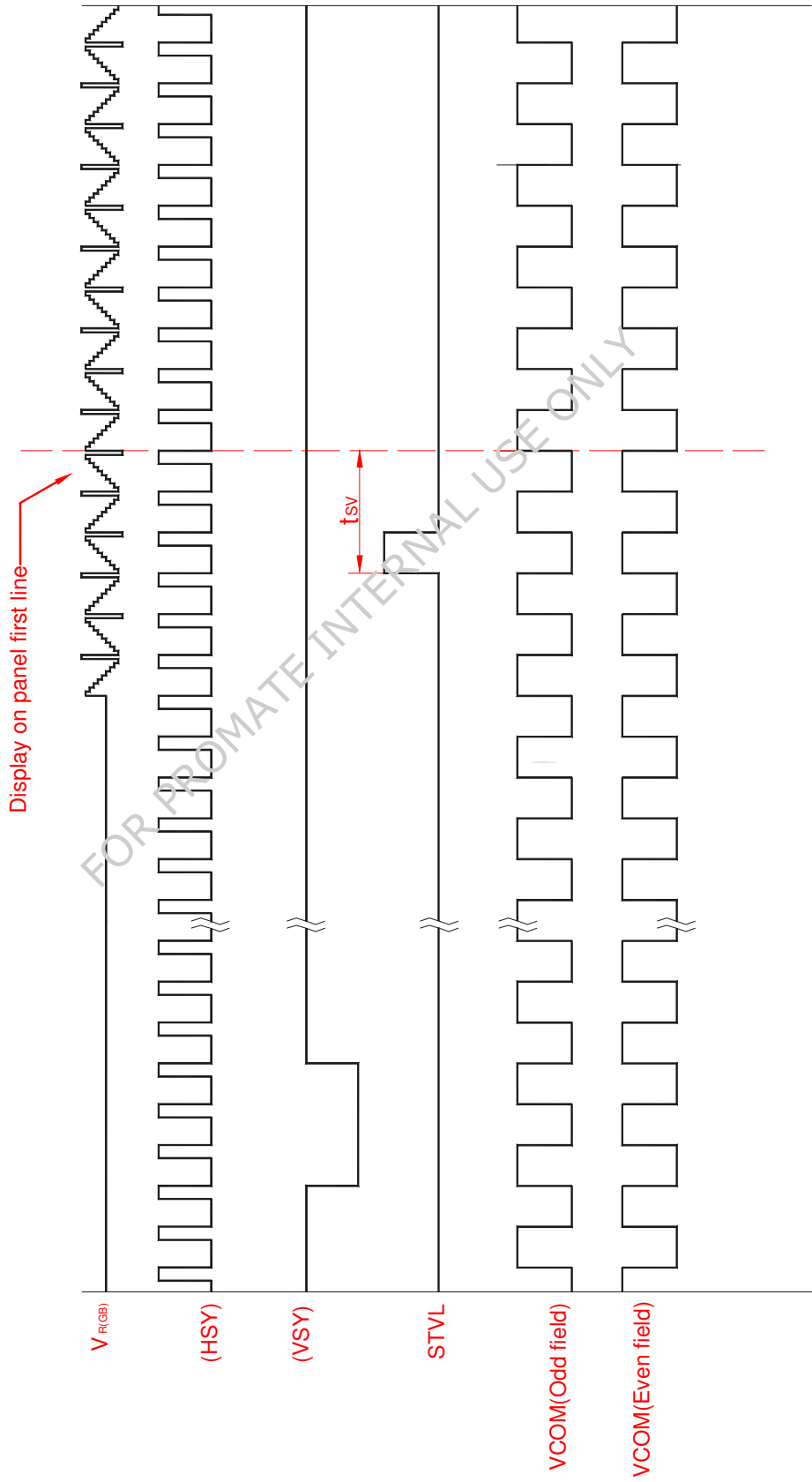

Fig. 6-(b) Vertical timing (From down to up)