



Specifications Approval Sheet

Product Description: 10.2" COLOR TFT-LCD MODULE			
AU Model Name: A102VW01			
Customer Part No:			
Customer Signature	Date	AU	2004/12/16
		Approved By: 徐萬記	
		Reviewed By: 徐萬記	
		Prepared By: 程銀宗	

Please return one copy with your signature and comments for our confirmation.

AU Optronics Corporation

Tel: +886-3-563-2899

Fax: +886-3-564-5785



Version	7
Total pages	18
Date	2004.12.16

Product Specification

10.2" color TFT-LCD module

MODEL NAME: A102VW01

- Preliminary Specification
- Final Specification

Note: The content of this specification is subject to change.

© 2003 AU Optronics
All Rights Reserved,
Do Not Copy.



Contents:

A. Physical specification..... P3

B. Electrical specifications..... P4

1. Pin assignment..... P4

 a. TFT-LCD panel driving section..... P4

 b. Backlight driving section..... P5

2. Absolute maximum ratings..... P5

3. Electrical characteristics..... P6

 a. Typical operating conditions..... P6

 b. Current consumption..... P6

 c. Backlight driving conditions..... P6

4. AC Timing..... P7

 a. Timing conditions..... P7

 b. Timing diagram..... P7

C. Optical specifications..... P8

D. Reliability test items..... P10

E. Packing form..... P11

Appendix:

Fig.1 Outline dimension of TFT-LCD module (Front Side).....	P12
Fig.2 Outline dimension of TFT-LCD module (Rear Side)	P13
Fig.3 Operation Mode 1.....	P14
Fig.4 Operation Mode 2	P15
Fig.5 Horizontal timing.....	P16
Fig.6 Vertical shift timing	P17
Fig.7 Vertical timing (from up to down)	P18

A. Physical specifications

NO.	Item	Specification	Remark
1	Display resolution (dot)	800RGB(W)x480(H)	
2	Active area (mm)	222.0(W)x133.2(H)	
3	Screen size (inch)	10.2(Diagonal)	
4	Pixel pitch (mm)	0.2775(W)x0.2775(H)	
5	Color configuration	R. G. B. stripe	
6	Overall dimension (mm)	235.0(W)x145.8(H)x5.9(D)	Note 1
7	Weight (g)	335 ±10	
8	Surface treatment	Anti-Glare	
9	Backlight unit	CCFL	

Note 1: Refer to Fig.1 and Fig.2

B. Electrical specifications

1. Absolute Maximum Ratings

Items	Symbol	Product Specification			Unit
		Min.	Typ.	Max.	
Power Voltage	V _{CC}	-0.5		5	V
	AVDD	-0.5		12	V
	V _{GH}	-0.3		18	V
	V _{GL}	-15		0.3	V
	V _{GH-VGL}			33	V
Input Signal Voltage	V _i	-0.3		V _{CC} +0.3	V
	V _{ref} (V1~V8)	0.4AVDD		AVDD+0.3	V
	V _{ref} (V8~V14)	-0.3		0.6AVDD	V
	V _{com}	3.27		3.89	V
Operating Temperature	T _{opa}	-30		85	
Storage Temperature	T _{stg}	-40		85	

2. Typical operating conditions (GND=AVSS=0V)

Items	Symbol	Product Specification			Unit
		Min.	Typ.	Max.	
Power Voltage	V _{CC}	3.0	3.3	3.6	V
	AVDD	8.2	8.8	9.2	V
	V _{GH}	14.3	15	15.7	V
	V _{COM}	3.3	3.6	3.8	V
	V _{GL}	-6.8	-7.0	-7.2	V
Input Reference Voltage	V1~V5	0.4AVDD	—	AVDD-0.3	V
	V6~V10	0.1	—	0.6AVDD	V
Input H/L level Voltage	V _{IH}	0.8V _{CC}	—	V _{CC}	V
	V _{IL}	0	—	0.2V _{CC}	V

3. Current consumption conditions(GND=Avss=0V)

Parameter	Symbol	Condition	Min.	Typ.	Max.	Unit
Current For Driver	I _{GH}	V _{GH} =15V		(50)	(100)	uA
	I _{GL}	V _{GL} =-7V		(-0.2)	(-0.6)	mA
	I _{CC}	V _{CC} =3.3V		(3.5)	(5)	mA
	I _{DD}	AVDD=8.8V		(20)	(30)	mA

4. Backlight driving conditions

Parameter	Symbol	Condition	Min.	Typ.	Max.	Unit
Lamp Life Time	-	-	20,000	30,000	-	Hours
Voltage	V_L			770	830	Vrms
Current	I_L			6.0	7.0	mA
Frequency	F_L			60	80	KHz
Lamp Start Voltage	V_s	T=25			1,420	Vrms
		T=0			1,850	Vrms
		T=-20			TBD	Vrms
		Dark (Note)			1,850	Vrms

The "Lamp life time" is defined as the module brightness decrease to 50% original brightness at $T_a=25^\circ\text{C}$, $I_L=6\text{mA}$. The lamp driving voltage is measured from the panel connector site.

Note: In 14lux dark environment after leaving for 24 hours

5. Timing conditions

AC Electrical Characteristics ($V_{CC}=3.3\text{V}$, $AV_{DD}=8.4\text{V}$, $AV_{SS}=\text{GND}=0\text{V}$, $T_A=25^\circ\text{C}$)

Parameter	Symbol	Min.	Typ.	Max.	Unit
CLK frequency	Fclk		40	42	MHz
CLK pulse width	TCW	6			ns
Data set-up time	Tsu	4			ns
Data hold time	Thd	2			ns
Propagation delay of DIO2/1	Tphl	6	10	15	ns
Time that the last data to LD	Tld	1			Tcw
Pulse width of LD	Twld	2			Tcw
Time that LD to DIO1/2	Tlds	5			Tcw
POL set-up time	Tpsu	6			ns
POL hold time	Tphd	6			ns
OEV pulse width	TOEV		12		Tcw
CKV pulse width	TCKV	16	28	40	Tcw
Horizontal display start	TSH		0		Tcw/3
Horizontal display timing range	TDH		800		Tcw/3
STV setup time	TSUV	400			ns
STV hold time	THDV	400			ns
STV pulse width	TSTV			1	TDH
Horizontal lines per field	TV	512	525	610	TDH
Vertical display start	TSV		3		TDH
Vertical display timing range	TDV		480		TDH

DC Electrical Characteristics

Parameter	Symbol	Min.	Typ.	Max.	Unit
Supply Voltage	V_{CC}	2.7	3.3	3.6	V
Low Level Input Voltage	V_{IL}	0	-	$0.3 \cdot V_{CC}$	V
High Level Input Voltage	V_{IH}	$0.7 \cdot V_{CC}$	-	V_{CC}	V
High Level Output Voltage	V_{OH}	$V_{CC}-0.4$	-	-	V
Low Level Output Voltage	V_{OL}	GND	-	$\text{GND}+0.4$	V
Supply Voltage	AVDD	(6.5)	(8.8)	(10)	V
Sinking Current of Outputs	IOL	-80	-	-	uA
Driving Current of Outputs	IOH	80	-	-	uA

1.Pin assignment

a. TFT-LCD panel driving section

(1.)FH12-30S-0.5SH(Hirose) — FPC I/O Pin Assignment

Pin no	Symbol	I/O	Description	Remark
1	POL	O	Polarity selection	
2	DIO2	I/O	Vertical start pulse signal input or output	
3	OE	I	Output enable	
4	CPV	I	Vertical clock	
5	DIO1	I	Vertical start pulse signal input or output	
6	GND	I	Power ground	
7	EDGSL	I	Select rising edge or rising/falling edge	
8	VCC	I	Digital voltage for source driver	
9	V9	I	Gamma voltage level 9	
10	VGL	I	Gate OFF voltage	
11	V2	I	Gamma voltage level 2	
12	VGH	I	Gate ON voltage	
13	V6	I	Gamma voltage level 6	
14	U/D	I	Up/down selection	
15	VCOM1	I	Common voltage	
16	GND	I	Power ground	
17	AVDD1	I	Power supply for analog circuit	
18	V14	I	Gamma voltage level 14	
19	V11	I	Gamma voltage level 11	
20	V8	I	Gamma voltage level 8	
21	V5	I	Gamma voltage level 5	
22	V3	I	Gamma voltage level 3	
23	GND	I	Power ground	
24	R5	I	Red data(MSB)	
25	R4	I	Red data	
26	R3	I	Red data	
27	R2	I	Red data	
28	R1	I	Red data	
29	R0	I	Red data(LSB)	
30	GND	I	Power ground	

Pin no	Symbol	I/O	Description	Remark
31	GND	I	Power ground	
32	G5	I	Green data (MSB)	
33	G4	I	Green data	
34	G3	I	Green data	
35	G2	I	Green data	
36	G1	I	Green data	
37	G0	I	Green data (LSB)	
38	STHL	I/O	Horizontal start pulse signal input or output	
39	INV	I	Control signal are inverted by ASIC or not	
40	GND	I	Power ground	
41	DCLK	I	Sample clock	
42	DVDD	I	Voltage for digital circuit	
43	STHR	I/O	Horizontal start pulse signal input or output	
44	LD	I	Latches the polarity of outputs and switches the new data to outputs	
45	B5	I	Blue data (MSB)	
46	B4	I	Blue data	
47	B3	I	Blue data	
48	B2	I	Blue data	
49	B1	I	Blue data	
50	B0	I	Blue data (LSB)	
51	R/L	I	Right/ left selection	
52	V1	I	Gamma voltage level 1	
53	V4	I	Gamma voltage level 4	
54	V7	I	Gamma voltage level 7	
55	V10	I	Gamma voltage level 10	
56	V12	I	Gamma voltage level 12	
57	V13	I	Gamma voltage level 13	
58	AVDD2	I	Voltage for analog circuit	
59	GND	I	Power ground	
60	VCOM2	I	Common voltage	

C. Optical specification (Note 1, Note 2)

Item	Symbol	Condition	Min.	Typ.	Max.	Unit	Remark
Response time	Rise Fall	$=0^\circ$	- -	12 18	24 36	ms ms	Note 3,5
Contrast ratio	CR	At optimized Viewing angle	250	400	-		Note 4, 5
Viewing angle	Top Bottom Left Right	CR 10	40 55 55 55	45 65 65 65	- - - -	deg.	Note 5, 6
Brightness	Y_L	$I_L=6mA, 25$	350	400	-	nit	Note 7
White chromaticity	X	$=0^\circ$	0.26	0.29	0.34		Note 7
	Y	$=0^\circ$	0.28	0.32	0.36		

Note 1 : Ambient temperature $=25^\circ$, and lamp current $I_L = 6$ mArms. To be measured in the dark room. DC/AC inverter driving frequency: 60 kHz.

Note 2 :To be measured on the center area of panel with a viewing cone of 1° by Topcon luminance meter BM-5, after 10 minutes operation.

Note 3. Definition of response time:

The output signals of photo detector are measured when the input signals are changed from "black" to "white"(falling time) and from "white" to "black"(rising time), respectively. The response time is defined as the time interval between the 10% and 90% of amplitudes. Refer to figure as below.

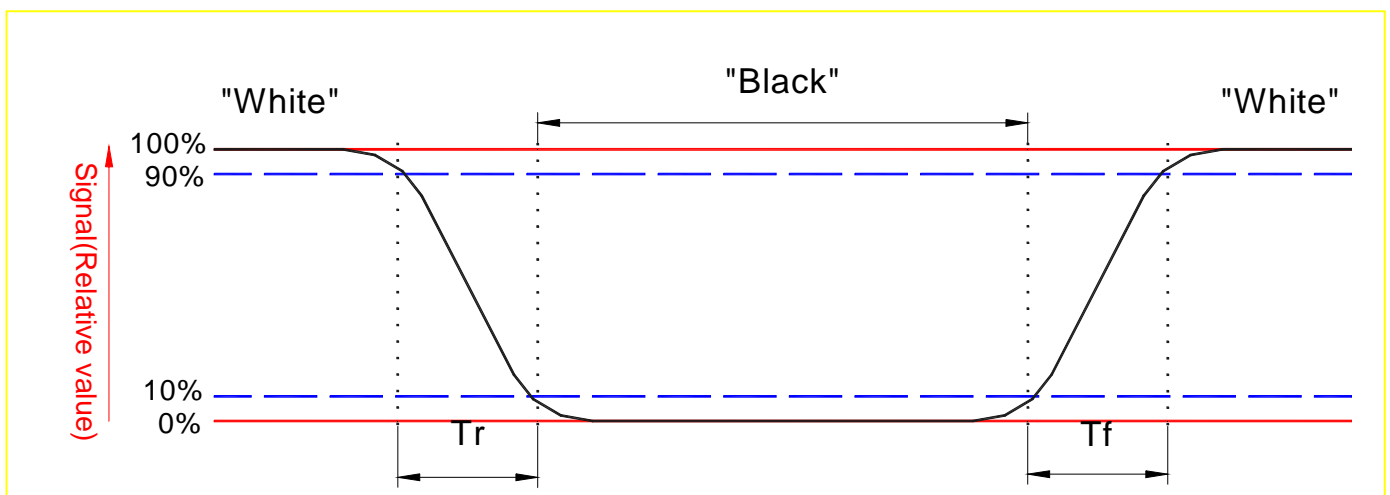

Note 4. Definition of contrast ratio:

Contrast ratio is calculated with the following formula.

$$\text{Contrast ratio (CR)} = \frac{\text{Photo detector output when LCD is at "White" state}}{\text{Photo detector output when LCD is at "Black" state}}$$

Note 5. The 100% transmission is defined as the transmission of LCD panel when all the input terminals of module are electrically opened.

Note 6. Definition of viewing angle, Refer to figure as below.

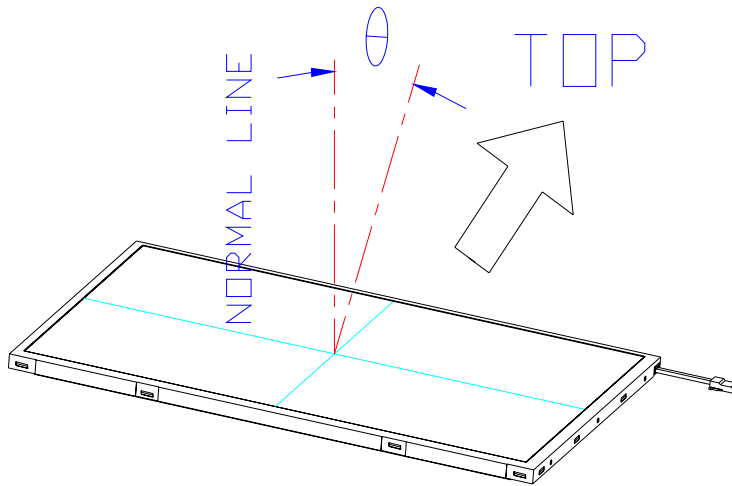

Note 7. Measured at the center area of the panel when all the input terminals of LCD panel are electrically opened.

D. Reliability test items(Note 2):

No.	Test items	Conditions	Remark
1	High temperature storage	Ta= 85 240Hrs	
2	Low temperature storage	Ta= -30 240Hrs	
3	High temperature operation	Tp= 85 240Hrs	
4	Low temperature operation	Ta= -40 240Hrs	
5	High temperature and high humidity	Tp= 60 , 90% RH 240Hrs	Operation
6	Thermal shock	-30 ~85 / 100 cycles 1Hrs/cycle	Non-operation
7	Electrostatic discharge	±200V,200pF(0), once for each terminal	Non-operation
8	Vibration	Frequency range : 8~33.3Hz Stoke : 1.3mm Sweep : 2.9G, 33.3 ~ 400Hz Cycle : 15 minutes 2 hours for each direction of X,Z 4 hours for Y direction	JIS D1601, A-10 Condition A
9	Mechanical shock	100G, 6ms, ±X,±Y,±Z 3 times for each direction	JIS C0041, A-7 Condition C
10	Vibration (with carton)	Random vibration: 0.015G ² /Hz from 5~200Hz -6dB/octave from 200~500Hz	IEC 68-34
11	Drop (with carton)	Height: 60cm 1 corner, 3 edges, 6 surfaces	JIS Z0202

Note1: Ta: Ambient temperature.

Note2: Tp: Panel Surface Temperature

Note3: All the cosmetic specification is judged before the reliability stress.

E. Packing form

No.	Part Name	Part No.
1	FILM PROTECT	77.10A01.001
2	TAPE CREPED PAPER 40*20MM	80.14B04.003
3	SPEC LABEL 83*9	82.15M03.003
4	TAPE 18MM(W) L133x1	80.13B01.011
5	A/S Bag	79.10B01.002
6	Cushion T/B (EPP)	84.10A01.003
7	Cushion CEN (EPP)	84.10A01.004
8	Cushion L/R (EPP)	84.10A01.005
9	Carton AB	81.10B01.001
10	Label Carton	82.01A04.001

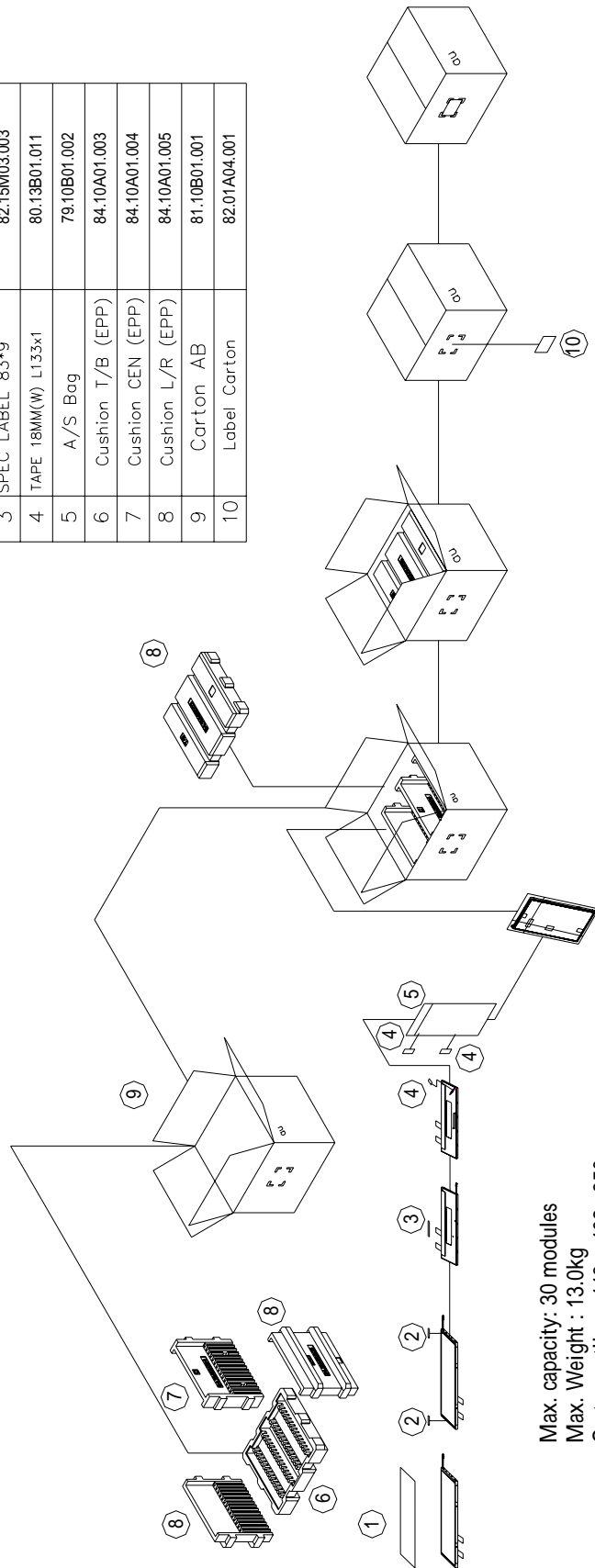

Max. capacity: 30 modules
Max. Weight : 13.0kg
Carton outline : 448 x 402 x350 mm

- NOTE: 1: 6 O'CLOCK DIRECTION IS THE OPTIMUM VIEWING ANGLE
 2: GENERAL TOLERANCE : 0.3mm
 3: ALLOWED DEPTH OF USERHOLE SCREW INSERTION IS 2.2mm MAX
 4: CCFL CONNECTOR FOR BACKLIGHT TO BE SPECIFIED IS JST BHSR-02VS-1

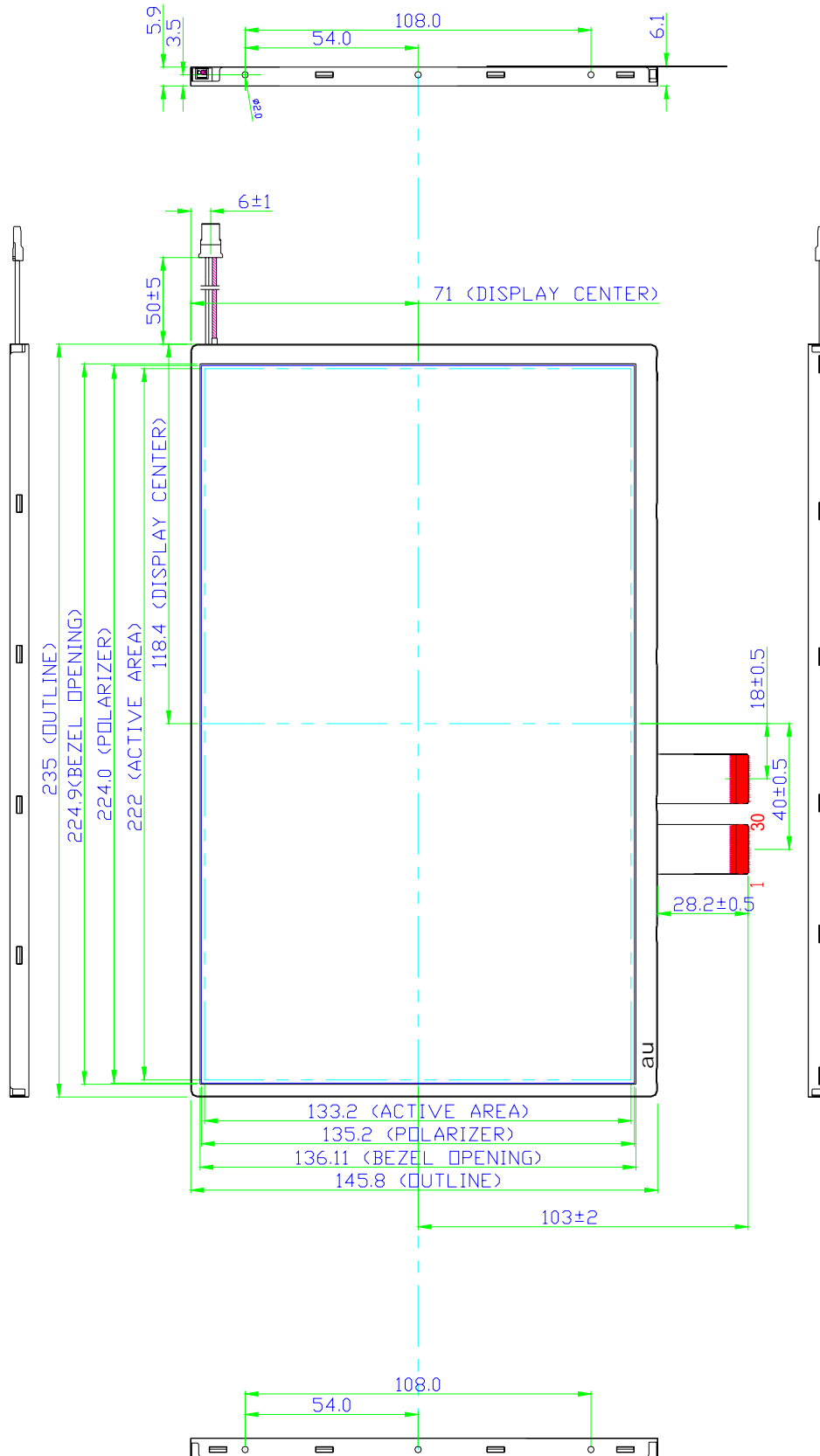

Fig.1 Outline dimension of TFT-LCD module (Front Side)

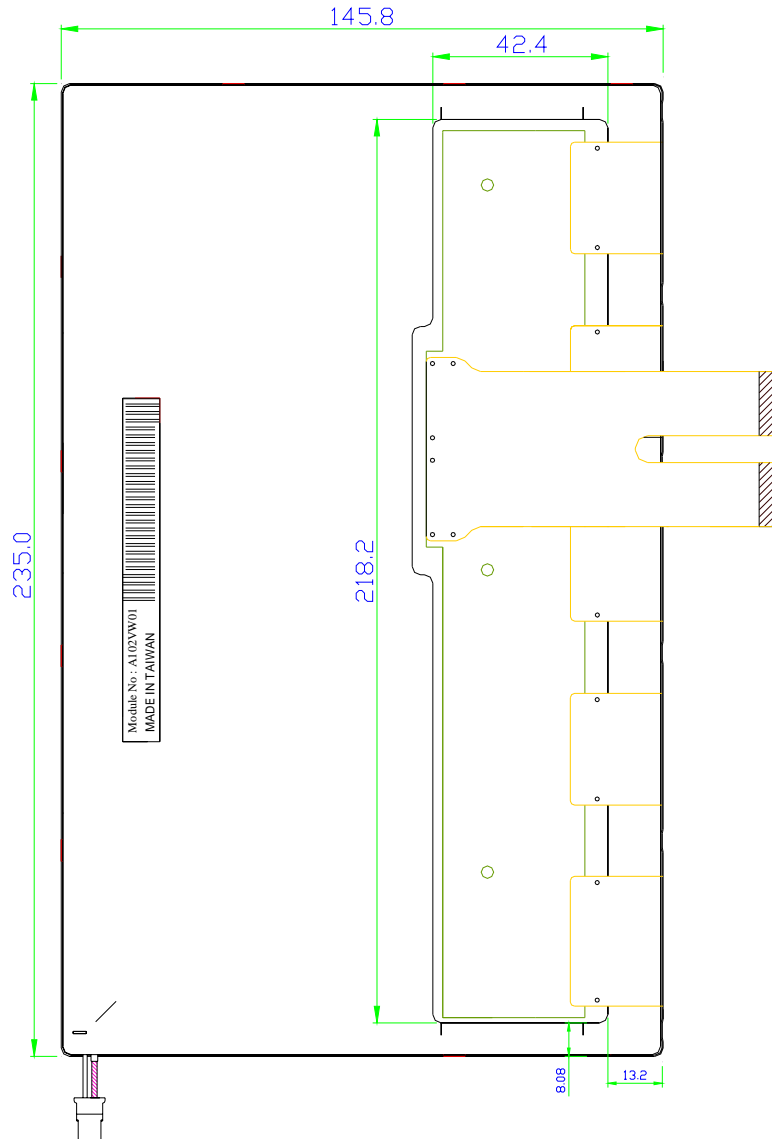

Fig.2 Outline dimension of TFT-LCD module (Rear Side)

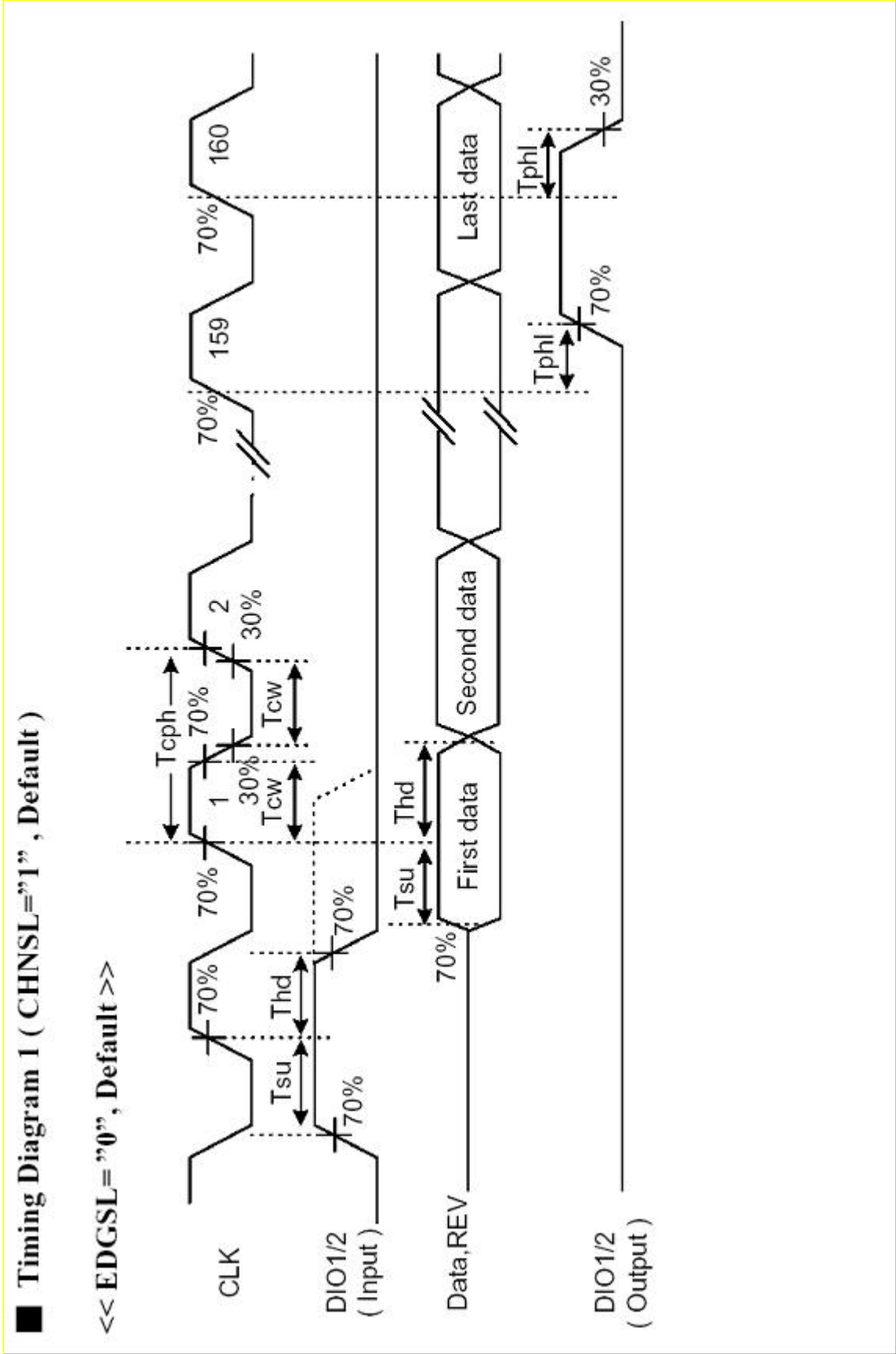

Fig.3 Operation Mode 1

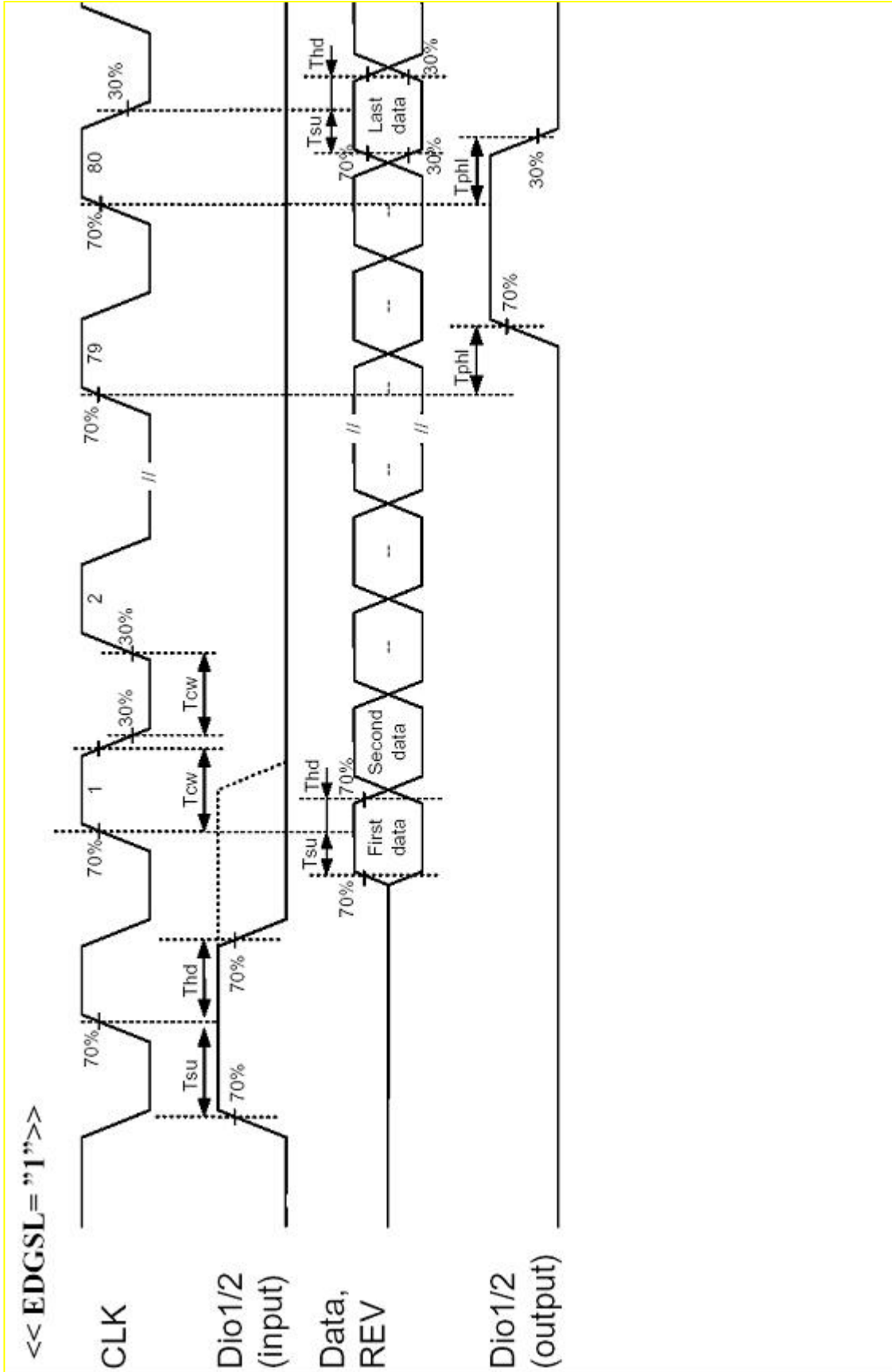

Fig.4 Operation Mode 2

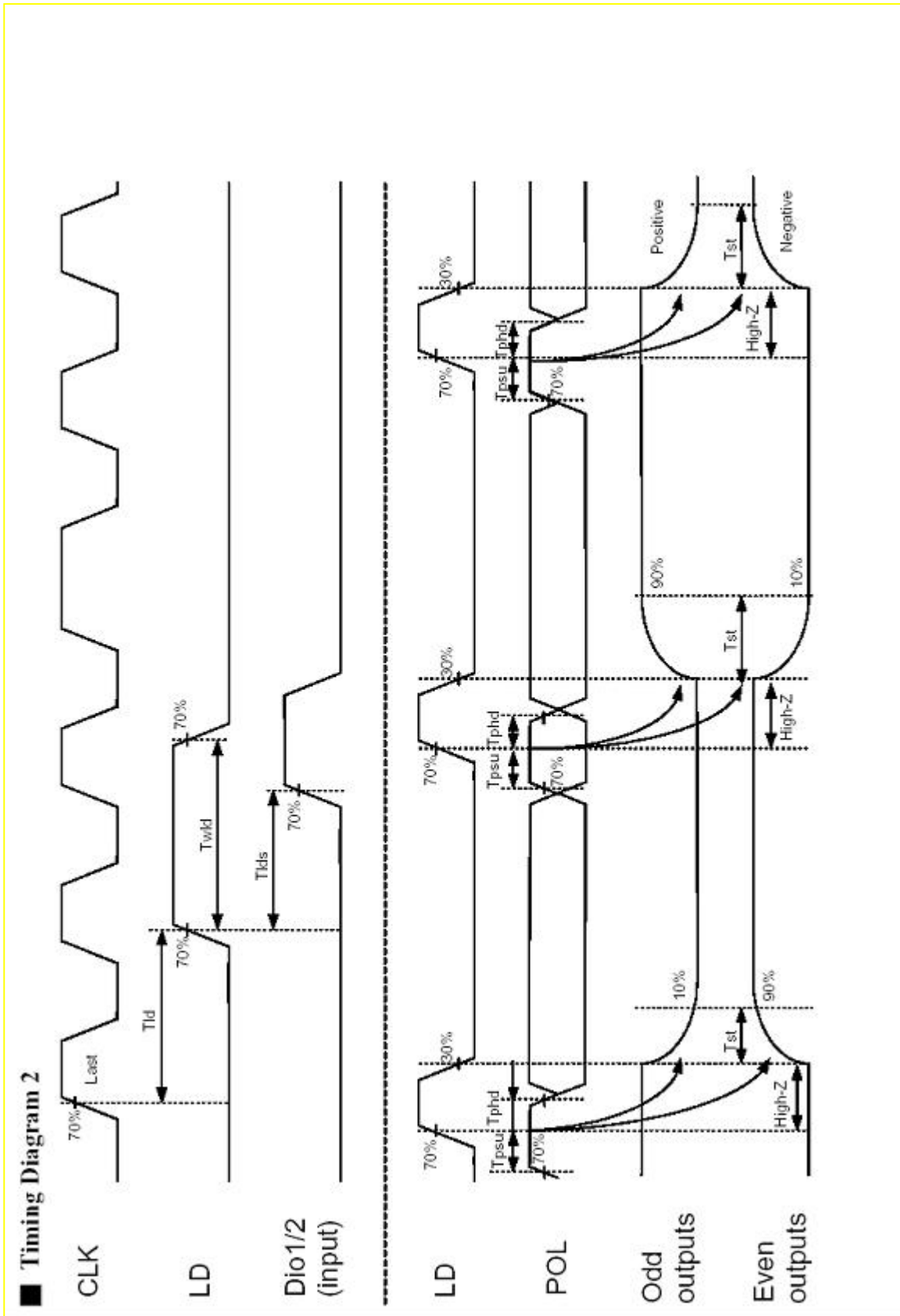

Fig.5 Horizontal timing

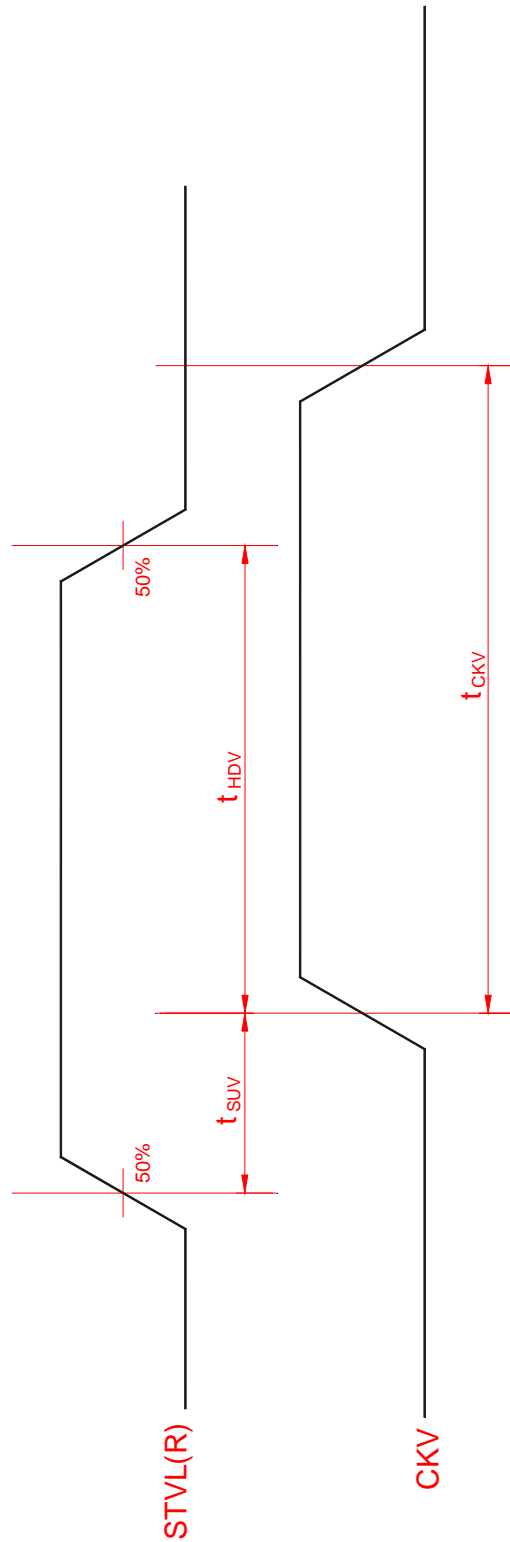

Fig.6 Vertical shift clock timing

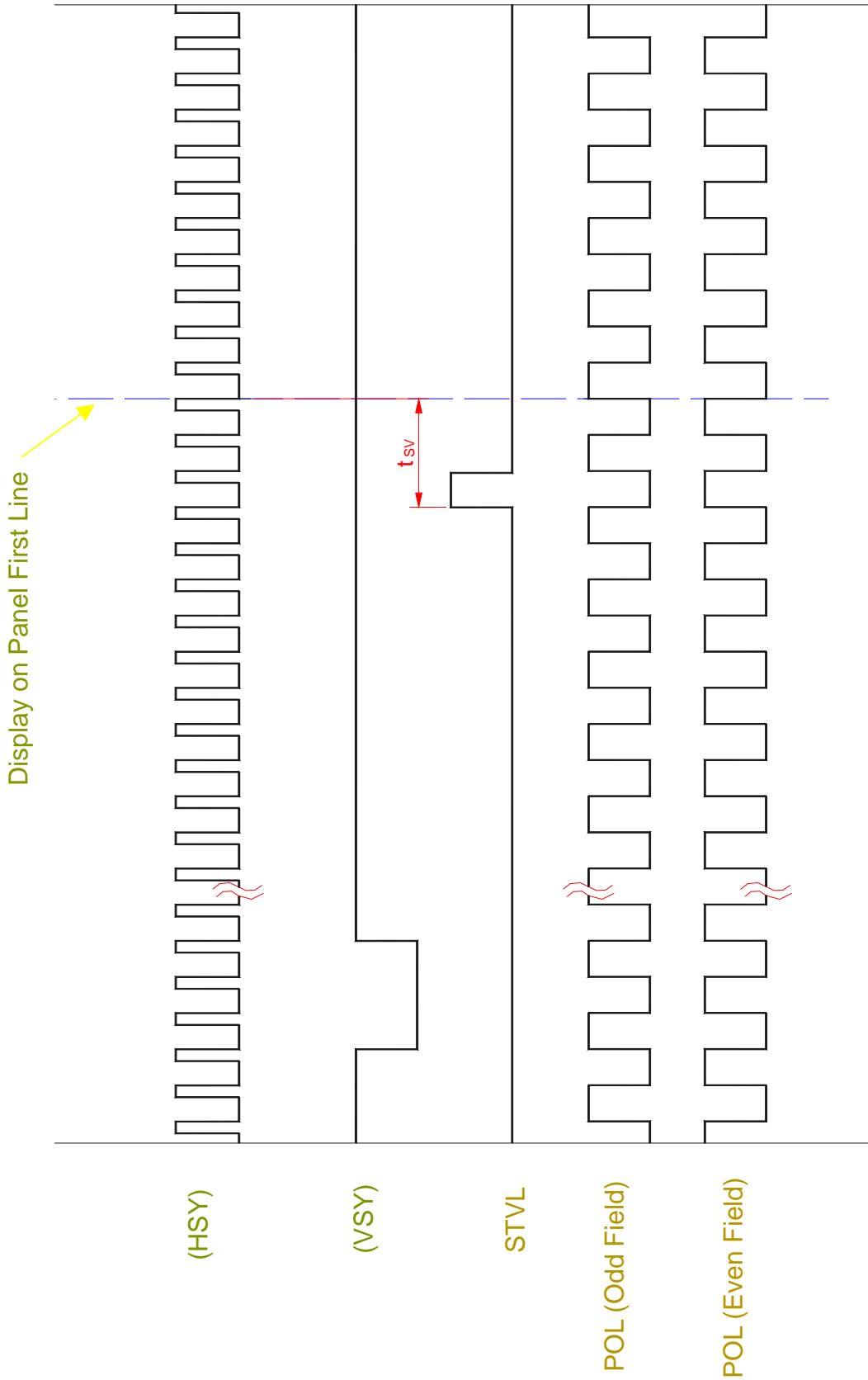

Fig.7 Vertical timing (from up to down)