

NHK® SERIES A ROCKER SWITCHES

A-25-15

SUPER-SUBMINIATURE/PCB MOUNTING/WASHABLE

Rocker

TYPICAL SWITCH ORDERING EXAMPLE

A 2 9 K V - C C

POLES	
1	SPDT
2	DPDT SP3T

PC TERMINALS	
P	Straight
B	Straight w/Bracket
B1	Straight w/Inline Bracket (SP only)
H	Right Angle w/Bracket
V	Vertical w/Bracket
V1	Vertical w/Inline Bracket (SP only)

CIRCUITS			
2	ON	NONE	ON
3	ON	OFF	ON
5	ON	NONE	(ON)
R	(ON)	NONE	ON
8	(ON)	OFF	(ON)
9	ON	OFF	(ON)
S	(ON)	OFF	ON
4	ON	ON	ON
6	(ON)	ON	(ON)
7	ON	ON	(ON)

() = Momentary

ACTUATORS	
K	Snap Top for Rocker AT469
K1	Snap Top for Rockers AT062 & AT066

ROCKERS	
C	.260" Wide
D	.250" Wide
E	.300" Wide

COLORS	
A	Black
B	White
C	Red

DESCRIPTION FOR TYPICAL ORDERING EXAMPLE (A29KV-CC)

SERIES A ROCKER

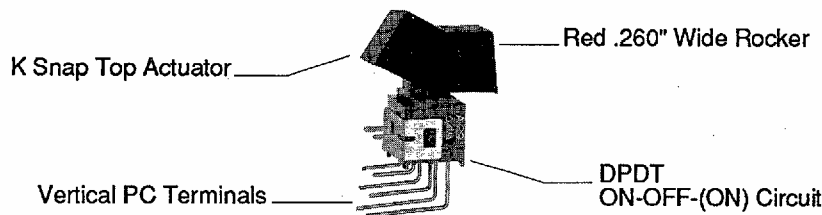



Electrical Capacity: 0.4VA max. @ 28V AC/DC max.
(See page A4 for further general specifications.)

NKK® SERIES A ROCKER SWITCHES

SUPER-SUBMINIATURE/PCB MOUNTING/WASHABLE

Rockers

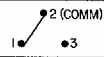
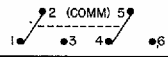
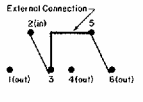
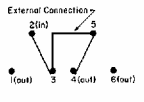
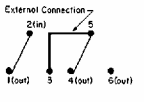
POLES AND CIRCUITS				
POLE & THROW	MODEL	ROCKER POSITION & TERMINAL NUMBER		
		() = Momentary		
		Up 	Center 	Down 
SPDT	A12	ON	NONE	ON
	A13	ON	OFF	ON
	A15	ON	NONE	(ON)
	A1R	(ON)	NONE	ON
	A18	(ON)	OFF	(ON)
	A19	ON	OFF	(ON)
	A1S	(ON)	OFF	ON
CONNECTED TERMINALS		2-3	OPEN	2-1
SCHEMATIC 				
DPDT	A22	ON	NONE	ON
	A23	ON	OFF	ON
	A25	ON	NONE	(ON)
	A2R	(ON)	NONE	ON
	A28	(ON)	OFF	(ON)
	A29	ON	OFF	(ON)
	A2S	(ON)	OFF	ON
CONNECTED TERMINALS		2-3 5-6	OPEN	2-1 5-4
SCHEMATIC 				
SP3T	A24	ON	ON	ON
	A26	(ON)	ON	(ON)
	A27	ON	ON	(ON)
CONNECTED TERMINALS W/O EXTRA CONNECTION		2-3 5-6	2-3 5-4	2-1 5-4
SCHEMATICS W/EXTERNAL CONNECTIONS				

Terminal numbers are not actually on switch. Additional 3-on info page A5.

PC TERMINALS

Gold Material Only
Rated 0.4VA max. @ 28V max. AC/DC

Dimensions for the following terminals appear on the rocker drawings in this section.

- | | |
|----------------------------------|----------------------------------|
| P Straight | H Right Angle |
| B Straight w/Bracket | V Vertical |
| B1 Straight w/Inline Brkt | V1 Vertical w/Inline Brkt |

Dimensions for W, D, R, & T long length terminals appear in the toggle section.

ACTUATORS

K Snap Top for Rocker AT469

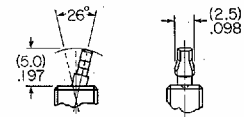

K1 Snap Top for Rockers AT062 and AT066

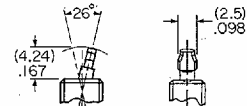

ROCKERS

C AT469 .260" Wide Rocker

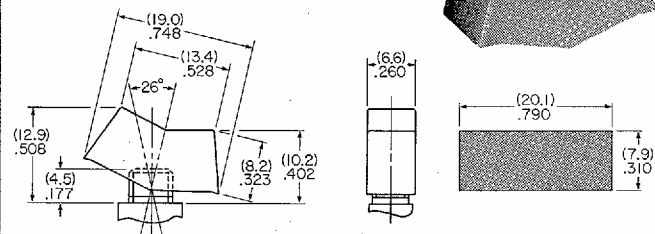

D AT062 .250" Wide Rocker

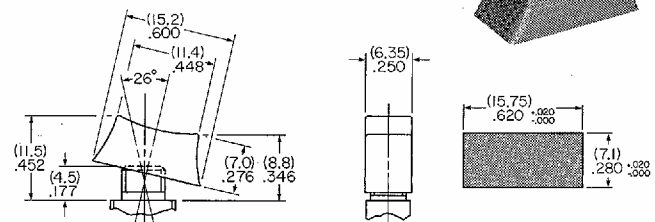

E AT066 .300" Wide Rocker

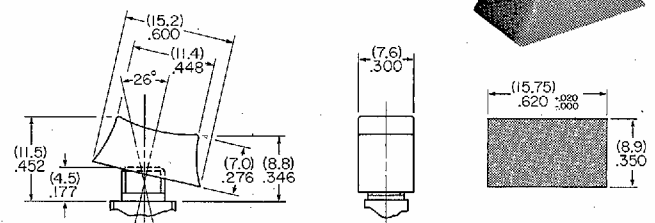

All Rockers are Antirotational
Material of Rockers: Nylon
Colors Available: **A** Black **B** White **C** Red
Contact factory for other colors.

NKK® SERIES A ROCKER SWITCHES

SUPER-SUBMINIATURE/PCB MOUNTING/WASHABLE

Rockers

P Straight Terminals without Bracket/Single Pole

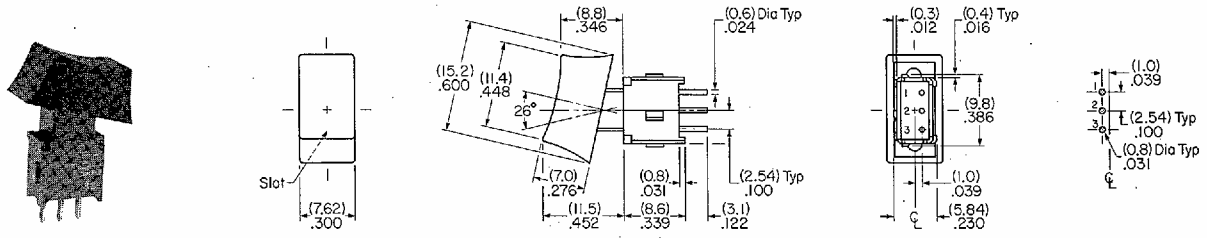

A12K1P-EA Model Shown

P Straight Terminals without Bracket/Double Pole

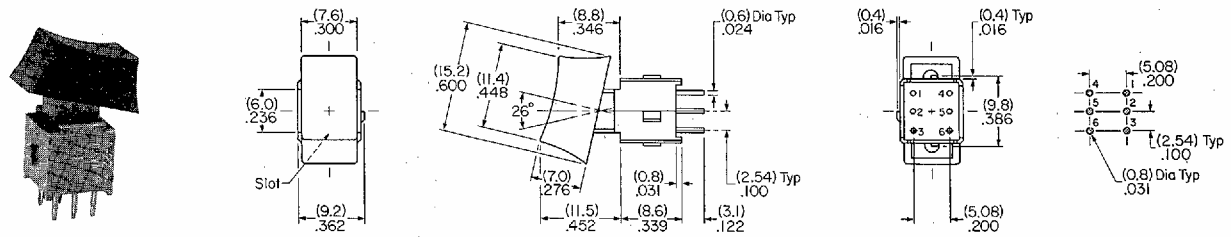

A22K1P-EA Model Shown

B B1 Straight Terminals with Bracket/Single Pole

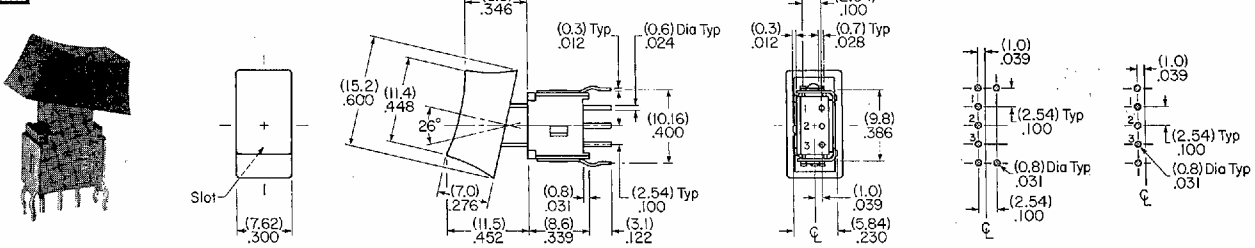

A12K1B-EA Model Shown

B Terminals

B1 Terminals

B Straight Terminals with Bracket/Double Pole

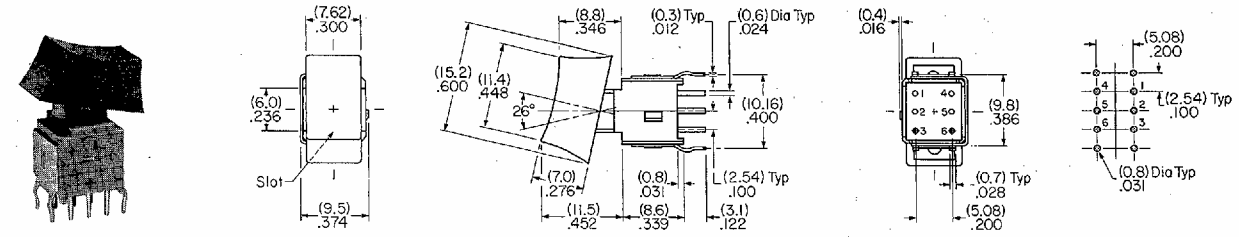

A22K1B-EA Model Shown

H Right Angle Terminals with Bracket/Single Pole

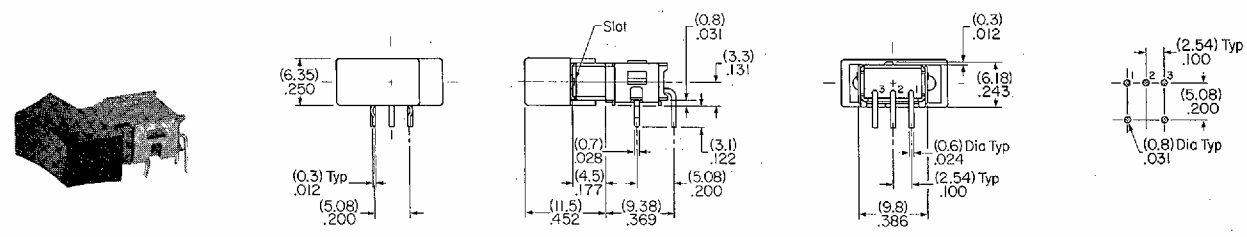

A12K1H-DA Model Shown

NKK® SERIES A ROCKER SWITCHES

SUPER-SUBMINIATURE/PCB MOUNTING/WASHABLE

Rockers

H Right Angle Terminals with Bracket/Double Pole



A22K1H-EA Model Shown

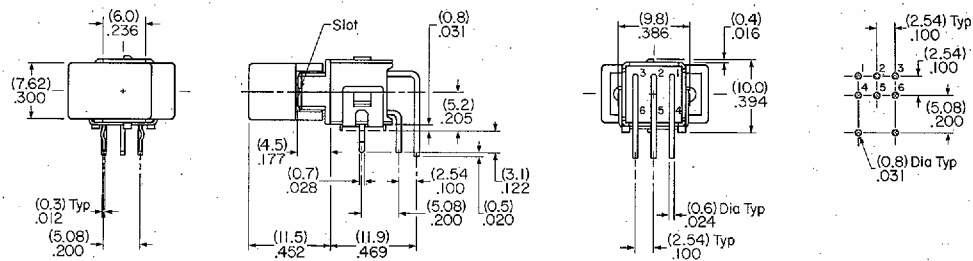

V V1 Vertical Terminals with Bracket/Single Pole

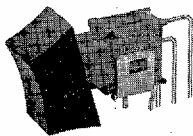

A12K1V-EA Model Shown

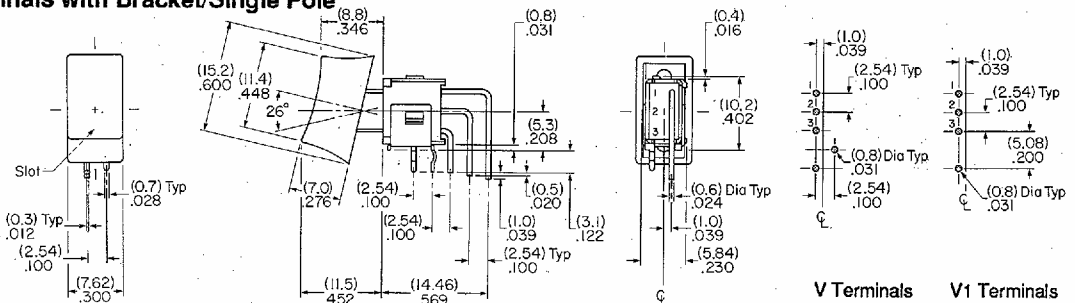

V Terminals V1 Terminals

V Vertical Terminals with Bracket/Double Pole



A22K1V-EA Model Shown

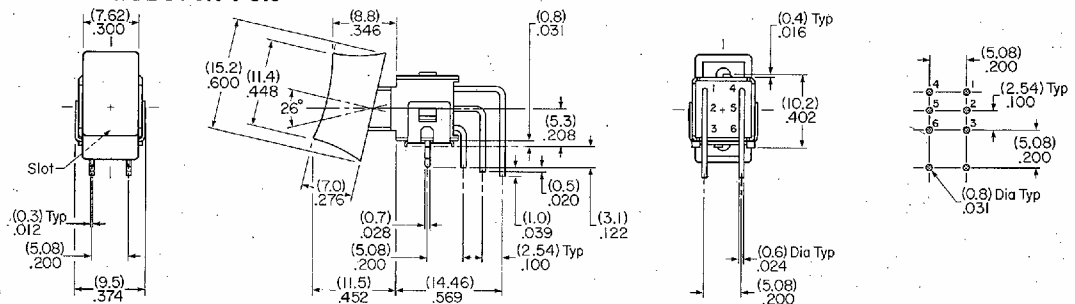

ROCKER MOUNTING PRECAUTION

Rocker switches with vertical and right angle terminals must be mounted so that extension of the PC board beyond the top of the switch housing does not interrupt rocker movement, in turn causing incomplete switching operation.

The MAXIMUM limit of the PC board extension is 1.3mm (.051"), as illustrated below.

This precaution does not apply to the double pole switch with right angle terminals due to the extra width of the switch allowing the rocker to clear the PC board.

End View of Rocker
Right Angle Mounting PC
Single Pole Only

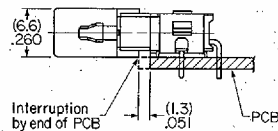

Side View of Rocker
Vertical Mounting PC
Single and Double Pole

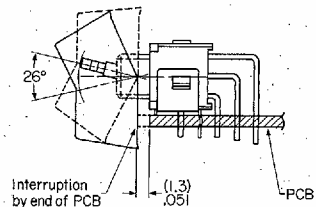

PCB MOUNTING AND SOLDERING CONSIDERATIONS

The use of a support bracket or placement of the square bushing in a panel cutout is recommended to increase PCB mounting stability.

Soldering time and temperature limits are 3 seconds at 350°C or 5 seconds at 270°C.

NKK[®]

SERIES A

SUPER-SUBMINIATURE/PCB MOUNTING/WASHABLE

A-25-13

DISTINCTIVE FEATURES



Super-subminiature size (1/3 size of Series M switches) saves space on PC boards.

Totally sealed body prevents contact contamination, allows time- and money-saving automated wave soldering and washing.

Patented Sliding Twin Crossbar (STC) mechanism provides unequalled logic-level reliability and smoother, positive detent actuation.

Molded-in, epoxy sealed terminals lock out flux, solvents, and other contaminants.

Actual Size



.100" x .100" terminal spacing conforms to standard PC board grid spacing.

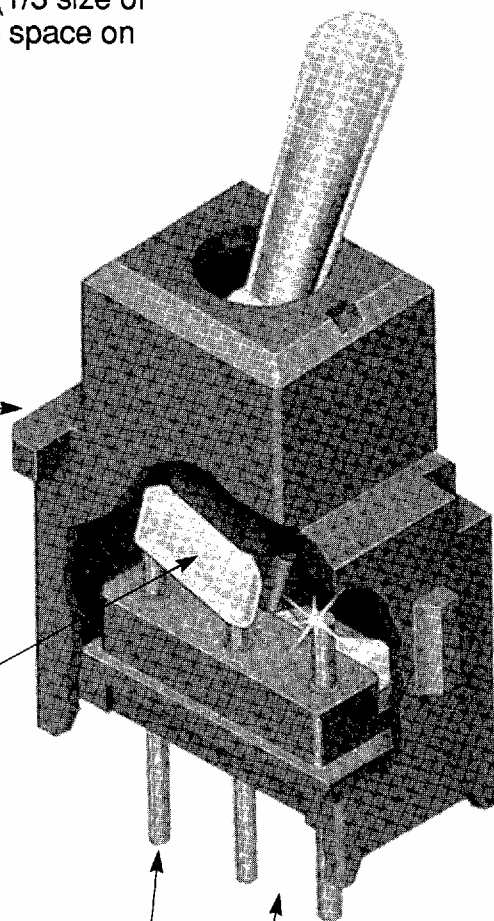

NKK® SERIES A SWITCHES

SUPER-SUBMINIATURE/PCB MOUNTING/WASHABLE

GENERAL SPECIFICATIONS

Electrical Capacity: (Resistive Load)	0.4VA maximum @ 28V AC/DC maximum (Applicable Range 0.1mA ~ 0.1A @ 20mV ~ 28V)
Contact Resistance:	50 milliohms maximum
Insulation Resistance:	500 megohms minimum @ 500V DC
Dielectric Strength:	500V AC minimum
Mechanical Life:	Toggles & Rockers: 100,000 operations minimum for ON-NONE-ON & ON-OFF-ON 50,000 operations minimum for other circuits Pushbuttons: 50,000 operations minimum
Electrical Life:	50,000 operations minimum
Ambient Temp Range:	-10°C through +85°C (+14°F through +185°F) Optional low temperature lubricant available
Toggle Angle of Throw:	26°
Rocker Angle of Throw:	26°
Pushbutton Travel:	Pretravel 0.7mm (.028") Overtravel 0.4mm (.016") Total 1.1mm (.043")
Nominal Operating Force:	Toggles A & E & K w/Long Paddle: 150g (momentary); 120g (maintained) Toggles J & H & K w/Short Paddle: 278g (momentary); 188g (maintained) Rockers w/Actuators K & K1: 253g (momentary); 206g (maintained) Pushbuttons: 260g

MATERIALS & FINISHES

Toggle/Rocker Actuator	Nickel plated brass
Pushbutton Plunger	Polyacetal
Case Housing	Glass fiber reinforced polyamide
Support Bracket	Tin plated phosphor bronze
Movable Contact	Phosphor bronze with gold plating over silver plating
Stationary Contacts	Brass with gold plating over nickel undercoating

SEALED FOR WASHABILITY

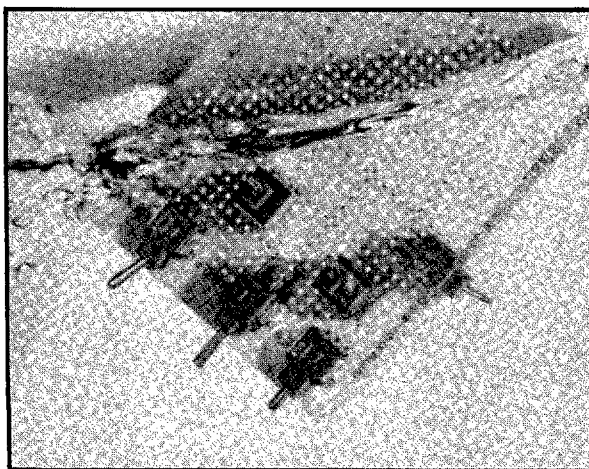

Sealed body construction permits Series A switches to be subjected to time- and money-saving automated soldering techniques. As a result, they can be safely cleaned of flux without fear of compromising operating characteristics.

STC CONTACT MECHANISM

NKK's patented, award-winning STC contact mechanism offers benefits unavailable in conventional mechanisms. For example, movable twin contact surfaces pinch the stationary contacts to provide increased contact stability and unparalleled logic-level reliability.

Continued reliability is assured since the gold-plated contacts are wiped clean with each actuation. Furthermore, if one side of the twin contacts should fail to conduct, the other side functions as a backup, or fail-safe path for the current. The combination of rounded movable and stationary contacts provides smooth contact feel previously unavailable in sliding contact type mechanisms.

