

Description

- General small signal amplifier

Features

- Low collector saturation voltage : $V_{CE(sat)} = -0.3V$ (Max.)
- Low output capacitance : $C_{ob} = 4pF$ (Typ.)
- Complementary pair with 2SC5343

Ordering Information

Type NO.	Marking	Package Code
2SA1980	A1980	TO-92

Outline Dimensions

unit : mm

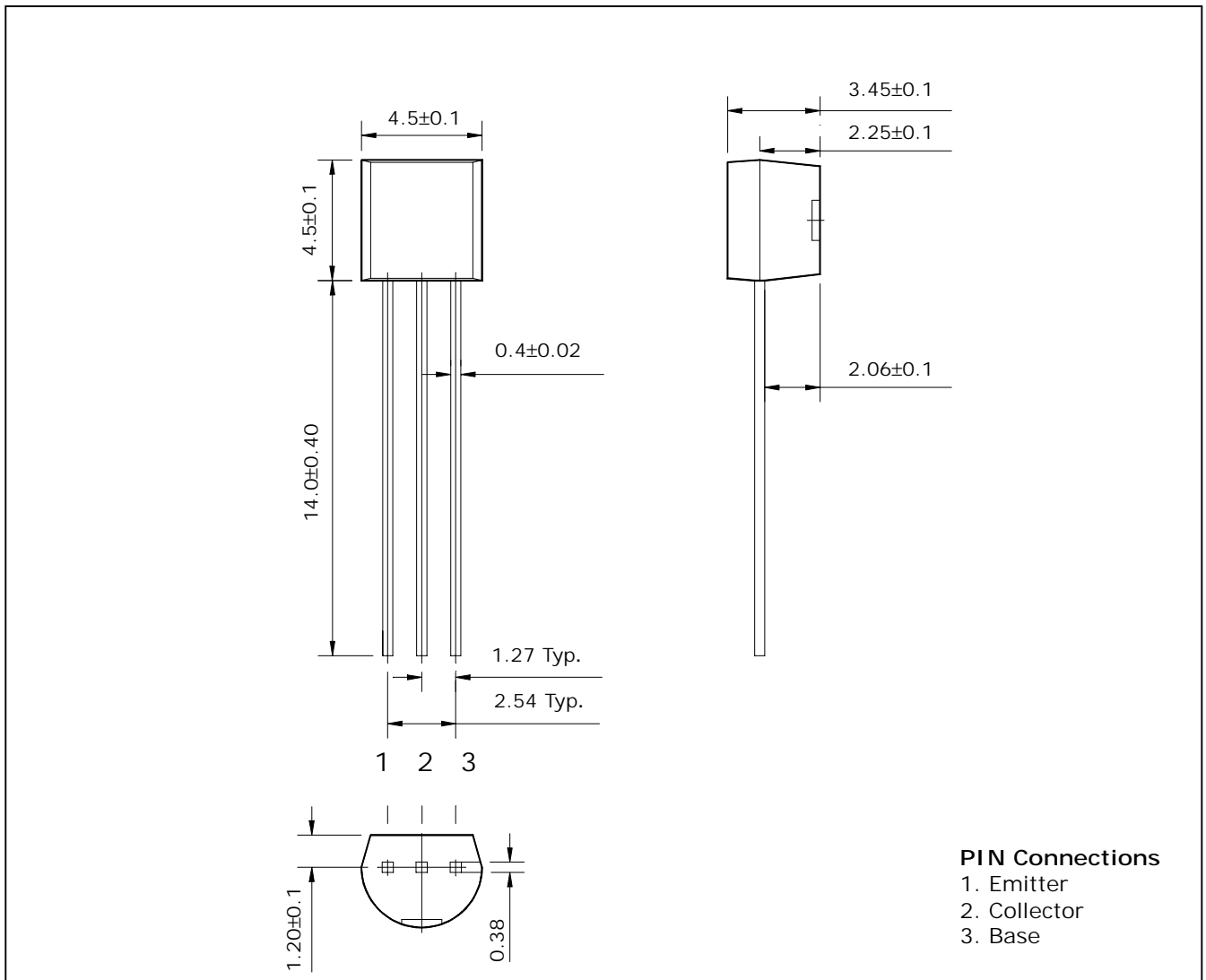

Absolute maximum ratings

(Ta=25°C)

Characteristic	Symbol	Ratings	Unit
Collector-Base voltage	V_{CBO}	-50	V
Collector-Emitter voltage	V_{CEO}	-50	V
Emitter-Base voltage	V_{EBO}	-5	V
Collector current	I_C	-150	mA
Collector dissipation	P_C	625	mW
Junction temperature	T_j	150	°C
Storage temperature	T_{stg}	-55 ~ 150	°C

Electrical Characteristics

(Ta=25°C)

Characteristic	Symbol	Test Condition	Min.	Typ.	Max.	Unit
Collector-Base breakdown voltage	BV_{CBO}	$I_C = -100\mu A, I_E = 0$	-50	-	-	V
Collector-Emitter breakdown voltage	BV_{CEO}	$I_C = -10mA, I_B = 0$	-50	-	-	V
Emitter-Base breakdown voltage	BV_{EBO}	$I_E = -10\mu A, I_C = 0$	-5	-	-	V
Collector cut-off current	I_{CBO}	$V_{CB} = -50V, I_E = 0$	-	-	-0.1	μA
Emitter cut-off current	I_{EBO}	$V_{EB} = -5V, I_C = 0$	-	-	-0.1	μA
DC current gain	h_{FE}^*	$V_{CE} = -6V, I_C = -2mA$	70	-	700	-
Collector-Emitter saturation voltage	$V_{CE(sat)}$	$I_C = -100mA, I_B = -10mA$	-	-	-0.3	V
Transition frequency	f_T	$V_{CE} = -10V, I_C = -1mA$	80	-	-	MHz
Collector output capacitance	C_{ob}	$V_{CB} = -10V, I_E = 0, f = 1MHz$	-	4	7	pF
Noise figure	NF	$V_{CE} = -6V, I_C = -0.1mA$ $f = 1KHz, R_g = 10K\Omega$	-	-	10	dB

*: h_{FE} rank / O : 70~140, Y : 120~240, G : 200~400, L : 300~700.

Electrical Characteristic Curves

Fig. 1 P_C - T_a

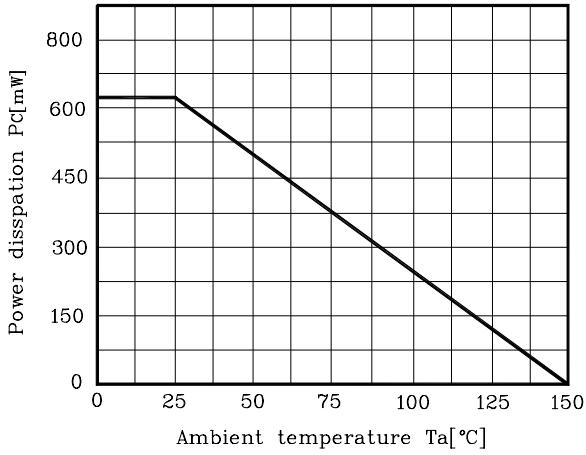

Fig. 2 I_C - V_{BE}

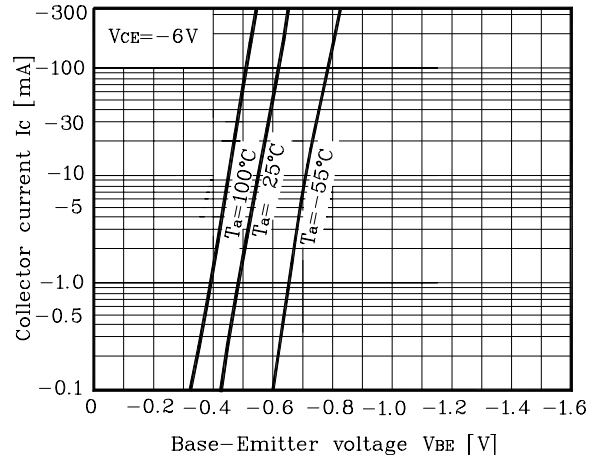

Fig. 3 I_C - V_{CE}

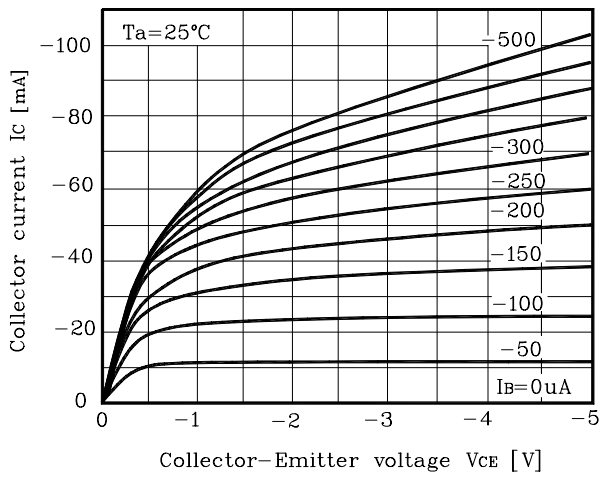

Fig. 4 h_{FE} - I_C

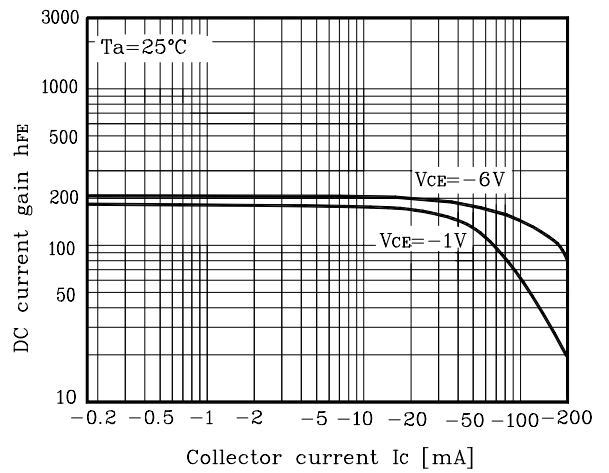

Fig. 5 $V_{CE(sat)}$ - I_C

