

Specifications

Model No. : A220Z-001
(CR 700:1)

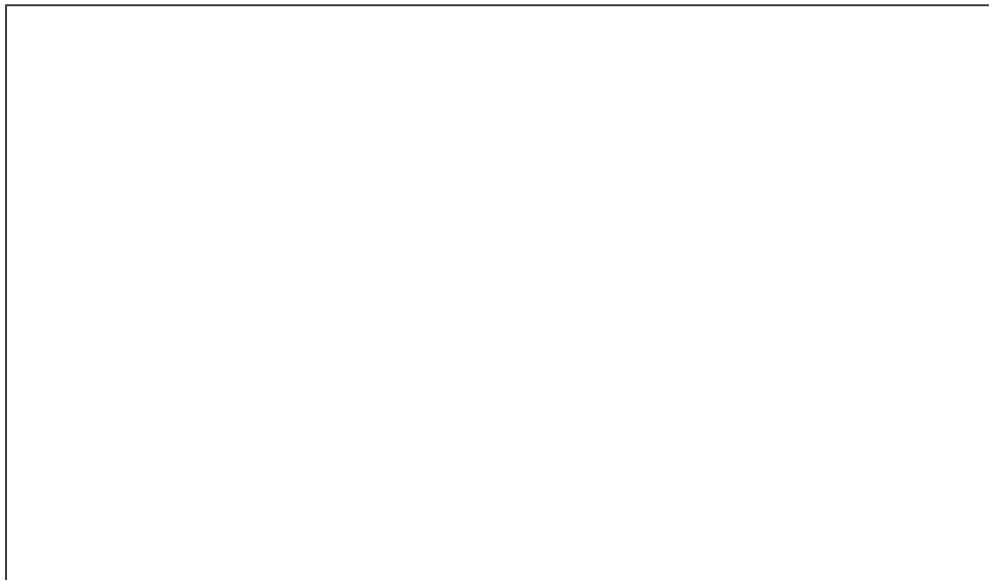

Liquid Crystal Display Division	
QRA Division.	OA Head Division.
Approval	Approval

- CONTENTS -

REVISION HISTORY	-----	3
1. GENERAL DESCRIPTION	-----	4
1.1 OVERVIEW		
1.2 FEATURES		
1.3 APPLICATION		
1.4 GENERAL SPECIFICATIONS		
1.5 MECHANICAL SPECIFICATIONS		
2. ABSOLUTE MAXIMUM RATINGS	-----	5
2.1 ABSOLUTE RATINGS OF ENVIRONMENT		
2.2 ELECTRICAL ABSOLUTE RATINGS		
2.2.1 TFT LCD MODULE		
2.2.2 BACKLIGHT UNIT		
3. ELECTRICAL CHARACTERISTICS	-----	7
3.1 TFT LCD MODULE		
3.2 BACKLIGHT UNIT		
4. BLOCK DIAGRAM	-----	11
4.1 TFT LCD MODULE		
4.2 BACKLIGHT UNIT		
5. INPUT TERMINAL PIN ASSIGNMENT	-----	12
5.1 TFT LCD MODULE		
5.2 BACKLIGHT UNIT		
5.3 COLOR DATA INPUT ASSIGNMENT		
6. INTERFACE TIMING	-----	15
6.1 INPUT SIGNAL TIMING SPECIFICATIONS		
6.2 POWER ON/OFF SEQUENCE		
7. DRIVER DC CHARACTERISTIC	-----	17
7.1 RSDS CHARACTERISTICS		
7.2 Electrical Characteristics		
8. Driver AC CHARACTERISTICS	-----	19
9. VERTICAL TIMING	-----	20
10. OPTICAL CHARACTERISTICS	-----	21
10.1 TEST CONDITIONS		
10.2 OPTICAL SPECIFICATIONS		
11. PACKAGING	-----	24
11.1 PACKING SPECIFICATIONS		
11.2 PACKING METHOD		
12. DEFINITION OF LABELS	-----	26
13. PRECAUTIONS	-----	27
13.1 ASSEMBLY AND HANDLING PRECAUTIONS		
13.2 SAFETY PRECAUTIONS		
14. MECHANICAL CHARACTERISTICS	-----	28

REVISION HISTORY

Version	Date	Section	Description
Ver 3.0	Dec, 12, '07	-	A220Z1 S-ISM Approval Specifications was first issued °

1. GENERAL DESCRIPTION

1.1 OVERVIEW

A220Z1-001 is a 22" wide TFT Liquid Crystal Display module with a 4-CCFL Backlight Unit and RSDS interface. This module supports 1680 x 1050 WSXGA⁺ (16:10 wide screen) mode and displays up to 16.7 millions colors. The inverter module for the Backlight Unit is not built in.

1.2 FEATURES

- Super wide viewing angle
- High contrast ratio
- Fast response time
- High color saturation (EBU Like Specifications)
- WSXGA⁺ (1680 x 1050 pixels) resolution
- DE (Data Enable) only mode
- RSDS (reduced swing differential signaling) interface
- RoHS Compliance

1.3 APPLICATION

- TFT LCD Monitor

1.4 GENERAL SPECIFICATIONS

Item	Specification	Unit	Note
Diagonal size	558.68	mm	
Active Area	473.76x296.1	mm	(1)
Bezel Opening Area	477.7 (H) x 300.1 (V)	mm	
Driver Element	a-Si TFT active matrix	-	-
Pixel Number	1680 x R.G.B. x 1050	pixel	-
Pixel Pitch	0.282(H) x 0.282(V)	mm	-
Pixel Arrangement	RGB vertical stripe	-	-
Display Colors	16.7 millions	color	-
Transmissive Mode	Normally White	-	-
Surface Treatment	Hard coating (3H), AG (Haze 25%)	-	-

1.5 MECHANICAL SPECIFICATIONS

Item	Min.	Typ.	Max.	Unit	Note	
Module Size	Horizontal(H)	493.2	493.7	494.2	mm	(1)
	Vertical(V)	319.6	320.1	320.6	mm	
	Depth(D)	16	16.5	17	mm	
Weight			2900	g		
I/F connector mounting position	The mounting inclination of the connector makes the screen center within ± 0.5 mm as the horizontal.					

Note (1) Please refer to the attached drawings for more information of front and back outline dimensions.

2. ABSOLUTE MAXIMUM RATINGS

2.1 ABSOLUTE RATINGS OF ENVIRONMENT

Item	Symbol	Value		Unit	Note
		Min.	Max.		
Storage Temperature	T _{ST}	-20	+60	°C	(1)
Operating Ambient Temperature	T _{OP}	0	+50	°C	(1), (2)
Shock (Non-Operating)	S _{NOP}	-	50	G	(3), (5)
Vibration (Non-Operating)	V _{NOP}	-	1	G	(4), (5)
LCD Cell Life Time	L _{CELL}	50,000	-	Hrs	MTBF based

Note (1) Temperature and relative humidity range is shown in the figure below.

(a) 90% RH Max. ($T_a \leq 40$ °C).

(b) Wet-bulb temperature should be 39 °C Max. ($T_a > 40$ °C).

(c) No condensation.

Note (2) The temperature of panel surface should be 0 °C Min. and 60 °C Max.

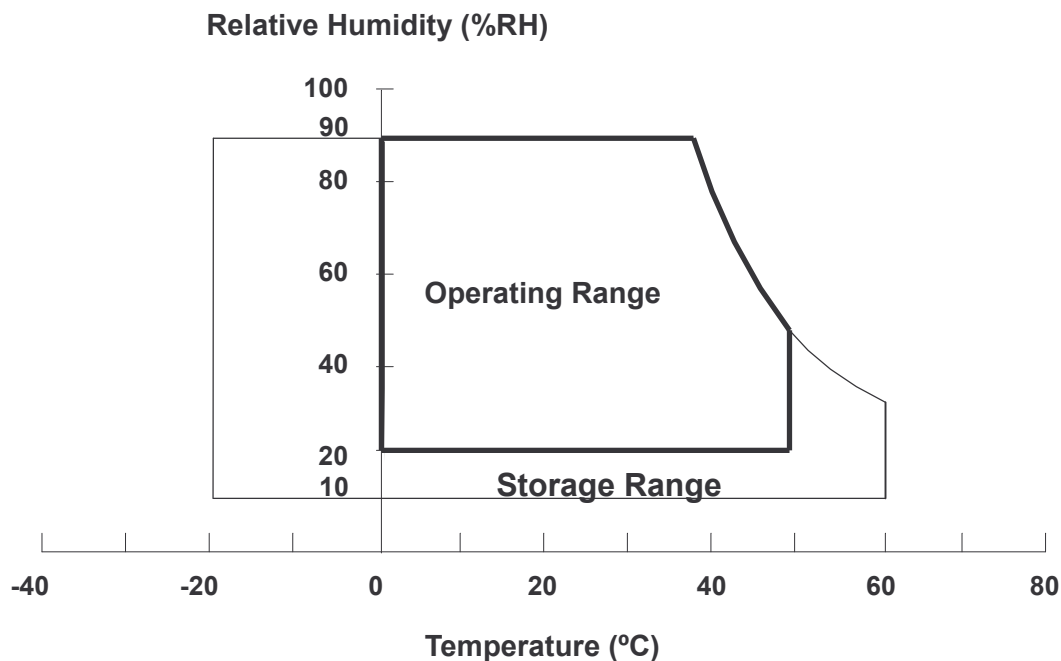

Note (3) 11 ms, half-sine wave, 1 time for $\pm X$, $\pm Y$, $\pm Z$.

Note (4) 10 ~ 300 Hz, sweep rate 10 min / cycle , 30 min for X,Y,Z axis

Note (5) Upon the Vibration and Shock tests, the fixture used to hold the module must be firm and rigid enough to prevent the module from twisting or bending by the fixture.

2.2 ELECTRICAL ABSOLUTE RATINGS

2.2.1 TFT LCD MODULE

Item	Symbol	Value		Unit	Note
		Min.	Max.		
Power Supply Voltage for LCD	V _{in}	12.42	15.18	V	(1)
Logic Input Voltage	V _{5A}	-0.3	6	V	
Logic Input Voltage	V _{DD}	-0.3	4	V	

2.2.2 BACKLIGHT UNIT

Item	Symbol	Value		Unit	Note
		Min.	Max.		
Lamp Voltage	V _L	-	2.5K	V _{RMS}	(1), (2), I _L = 7.0 mA
Lamp Current	I _L	3.0	8.0	mA _{RMS}	(1), (2)
Lamp Frequency	F _L	40	80	KHz	

Note (1) Permanent damage might occur if the module is operated at conditions exceeding the maximum values.

Note (2) Specified values are for lamp (Refer to 3.2 for further information).

3. ELECTRICAL CHARACTERISTICS

3.1 TFT LCD MODULE

Ta = 25 ± 2 °C

Parameter	SYMBOL	Value			UNIT	Note	
		MIN	TYP	MAX			
Power Supply Voltage for LCD	Vin	12.42	13.8	15.18	V		
Power Supply Current for LCD	Iin		300		mA		
Logic Input Voltage	V5A	4.75	5	5.25	V		
Logic Input Current	I5A		0.64		A		
Driver Logic Input Voltage	VDD	3.135	3.3	3.465	V		
Driver Logic Input Current	IDD		60		mA		
Differential Impedence	Zm		100		Ω		
Logic Input Voltage	High	VIH	0.8VDD	-	VDD	V	
	Low	VIL	0	-	VDD	V	
LCD Inrush Current	Irush		3		A	(2)	
Power Consumption	P		5		W		
PANEL On	High	PANEL_ON	2.5	3.3		V	MAX=3.6 is ok
	Low				0.6	V	
DCDC On	High	DCDC_ON	2.5	3.3		V	MAX=3.6 is ok
	Low				0.6	V	
VCOM PWM	High	VCOM_PWM	2.5			V	MAX=5.45 is ok
	Low				0.6	V	
VCOM PWM Frequency	VCOM_PWM		27		KHz	Adjustable Duty Cycle	

Note (1) The module should be always operated within above ranges.

Note (2) Measurement Conditions:

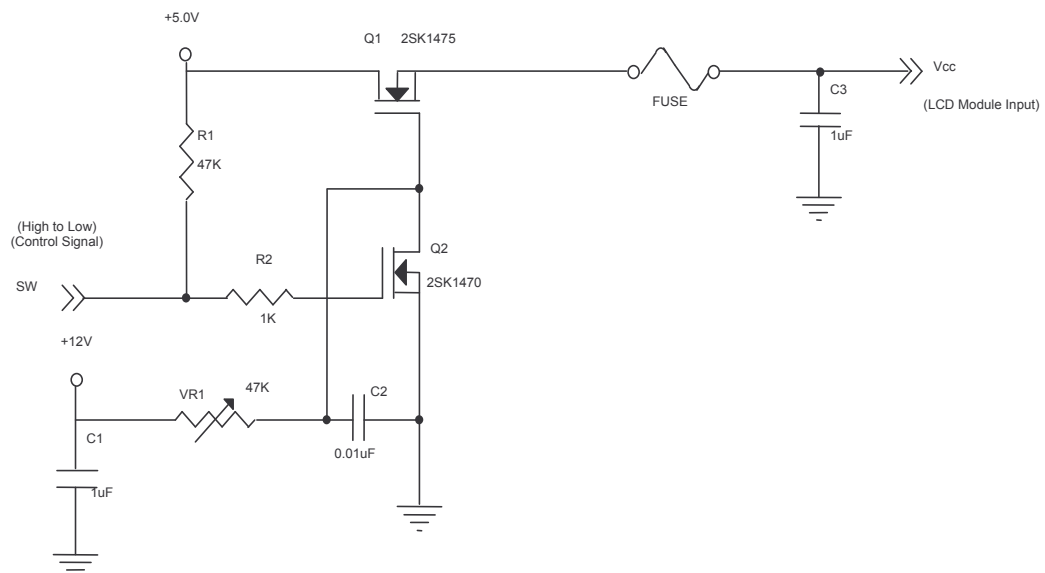

Vcc rising time is 470μs

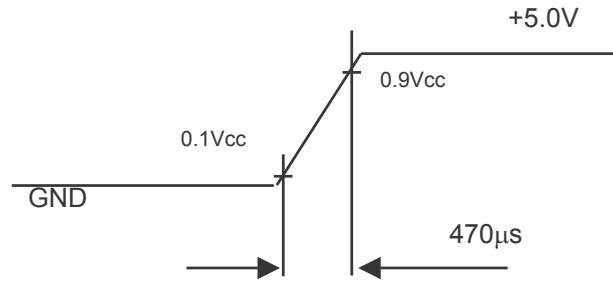

Note (3) The specified power supply current is under the conditions at $V_{cc} = 5.0\text{ V}$, $T_a = 25 \pm 2\text{ }^\circ\text{C}$, $f_v = 60\text{ Hz}$, whereas a power dissipation check pattern below is displayed.

a. White Pattern



Active Area

b. Black Pattern



Active Area

c. Vertical Stripe Pattern

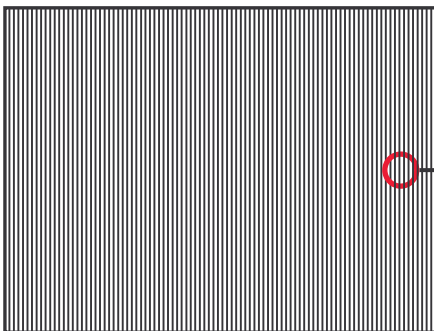

Active Area

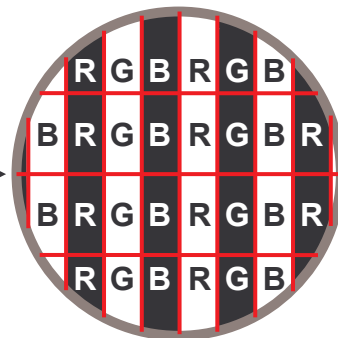

3.2 BACKLIGHT UNIT

Ta = 25 ± 2 °C

Parameter	Symbol	Value			Unit	Note
		Min.	Typ.	Max.		
Lamp Input Voltage	V _L	738	820	902	V _{RMS}	I _L = 7.0 mA
Lamp Current	I _L	3	7.0	8	mA _{RMS}	(1)
Lamp Turn On Voltage	V _s	-	-	1560(25°C)	V _{RMS}	(2)
		-	-	1800(0°C)	V _{RMS}	(2)
Operating Frequency	F _L	40	60	80	KHz	(3)
Lamp Life Time	L _{BL}	50000		-	Hrs	(5) I _L = (7.0) mA
Power Consumption	P _L	-	22.96	-	W	(4), I _L = 7.0 mA

Note (1) Lamp current is measured by utilizing high frequency current meters as shown below:

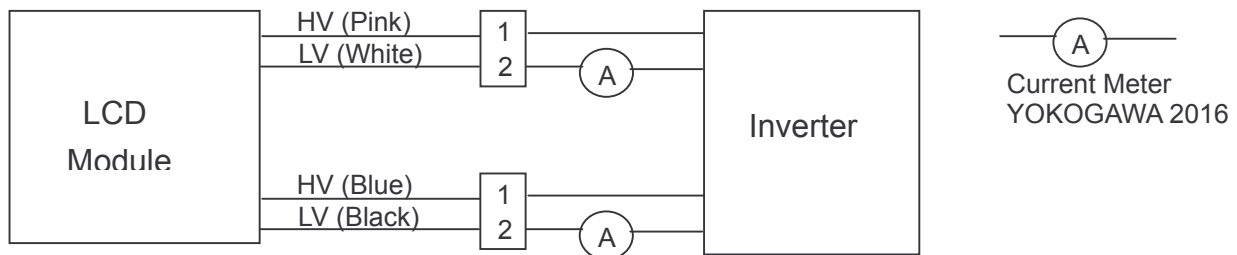

Note (2) The voltage that must be larger than V_s should be applied to the lamp for more than 1 second after startup. Otherwise the lamp may not be turned on.

Note (3) The lamp frequency may produce interference with horizontal synchronous frequency from the display, and this may cause line flow on the display. In order to avoid interference, the lamp frequency should be detached from the horizontal synchronous frequency and its harmonics as far as possible.

Note (4) $P_L = I_L \times V_L \times 4$ CCFLs

Note (5) The lifetime of lamp can be defined as the time in which it continues to operate under the condition Ta = 25 ± 2 °C and I_L = 7.0 mA rms until one of the following events occurs:

- (a) When the brightness becomes or lower than 50% of its original value.
- (b) When the effective ignition length becomes or lower than 80% of its original value. (Effective ignition length is defined as an area that has less than 70% brightness compared to the brightness in the center point.)

Note (6) The waveform of the voltage output of inverter must be area-symmetric and the design of the inverter must have specifications for the modularized lamp. The performance of the Backlight, such as lifetime or brightness, is greatly influenced by the characteristics of the DC-AC inverter for the lamp. All the parameters of an inverter should be carefully designed to avoid producing too much current leakage from high voltage output of the inverter. When designing or ordering the inverter please make sure that a poor lighting caused by the mismatch of the Backlight and the inverter (miss-lighting, flicker, etc.) never occurs. If the above situation is confirmed, the module should be operated in the same manners when it is installed in your instrument.

The output of the inverter must have symmetrical (negative and positive) voltage waveform and symmetrical current waveform. (Unsymmetrical ratio is less than 10%) Please do not use the inverter which has unsymmetrical voltage and unsymmetrical current and spike wave. Lamp frequency may produce interface with horizontal synchronous frequency and as a result this may cause beat on the display. Therefore lamp frequency shall be as away possible from the horizontal synchronous frequency and from its harmonics in order to prevent interference.

Requirements for a system inverter design, which is intended to have a better display performance, a better power efficiency and a more reliable lamp. It shall help increase the lamp lifetime and reduce its leakage current.

- a. The asymmetry rate of the inverter waveform should be 10% below;
- b. The distortion rate of the waveform should be within $\sqrt{2} \pm 10\%$;
- c. The ideal sine wave form shall be symmetric in positive and negative polarities.

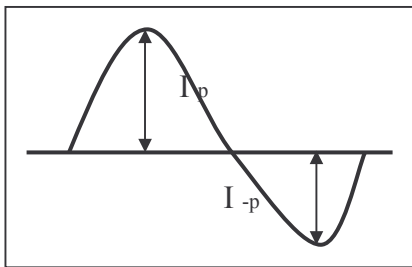

* Asymmetry rate:

$$| I_p - I_{-p} | / I_{rms} * 100\%$$

* Distortion rate

$$I_p \text{ (or } I_{-p}) / I_{rms}$$

4. BLOCK DIAGRAM

4.1 TFT LCD MODULE

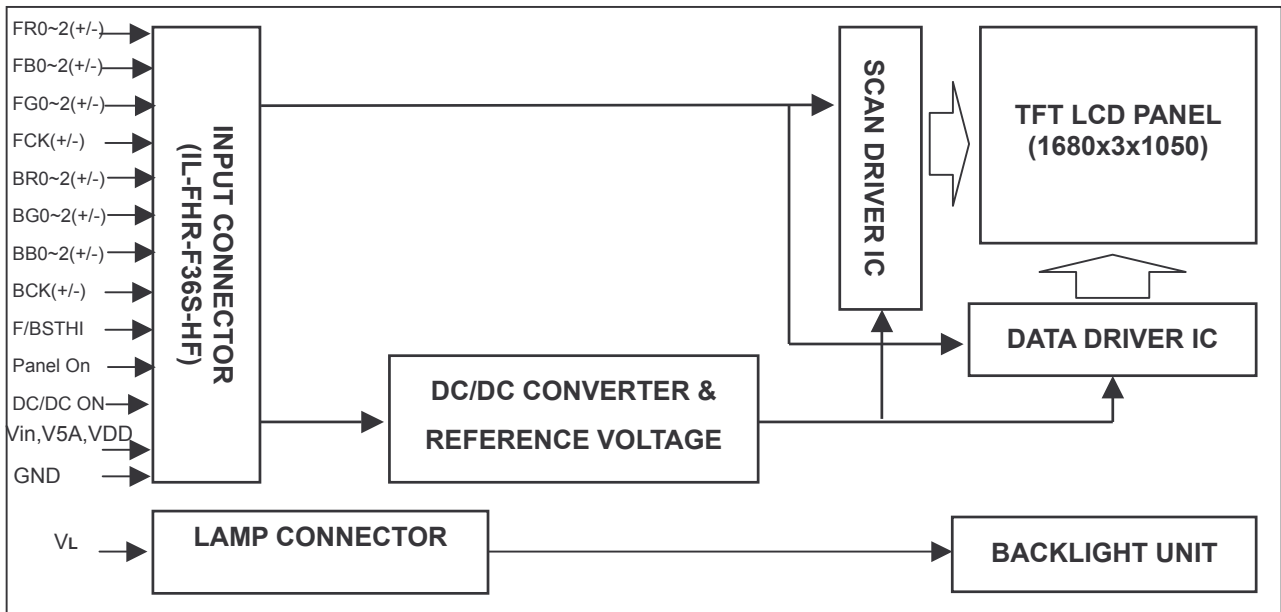

4.2 BACKLIGHT UNIT

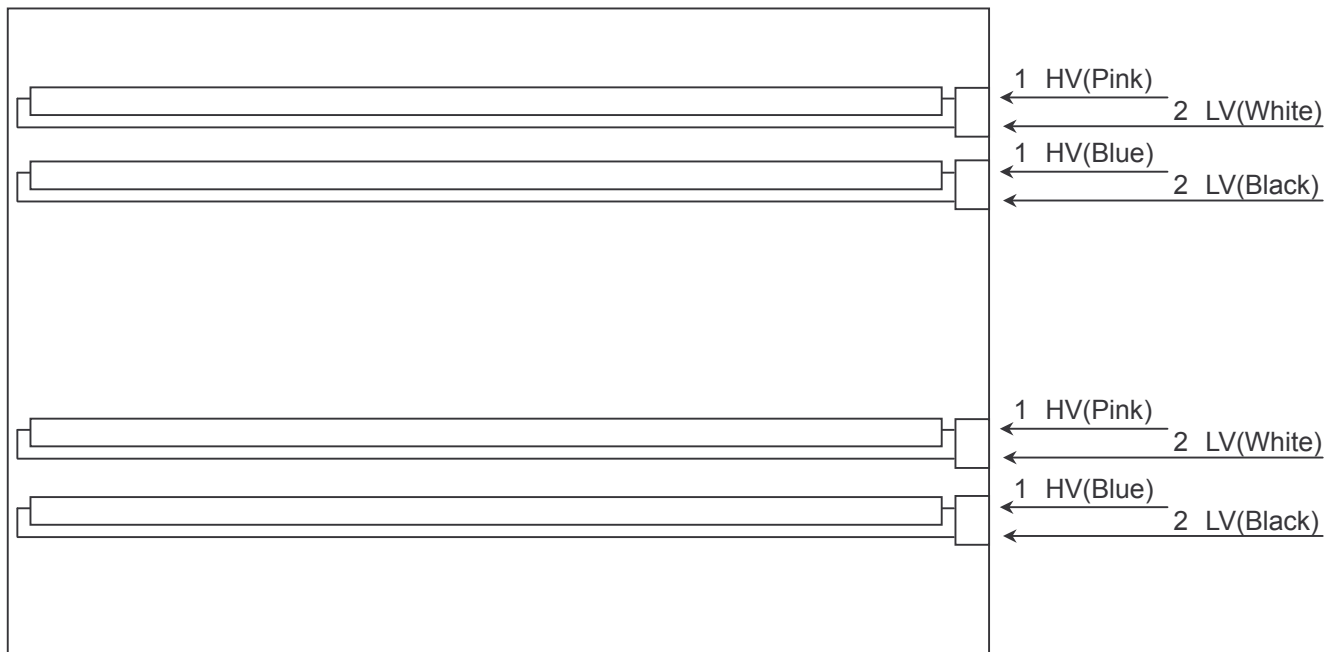

5. INPUT TERMINAL PIN ASSIGNMENT

5.1 TFT LCD MODULE

(1)CN1 (Panel Interface)

Pin	Name	Description
1	Vin	Driver Power Input Voltage
2	Vin	Driver Power Input Voltage
3	V5A	Logic Input Voltage +5V
4	PANEL_ON	This pin is used to control the driver Logic Input Voltage VDD. When PANEL_ON input is "H", VDD will be to driver.
5	DCDC_ON	This pin is used to control the PWM IC. When DCDC_ON input is "H", it enable PWM IC.
6	VCM_PWM	This pin is used to generate common voltage for panel. Adjust pulse width could be changed common voltage.
7	GVOFF	Gate driver high voltage switch timing control.
8	NC	No connect
9	GND	Ground
10	BSTHI	Data driver start pulse input(Back)
11	GND	Ground
12	BR0N	Negative RSDS differential data input. Channel R0(Back)
13	BR0P	Positive RSDS differential data input. Channel R0(Back)
14	BR1N	Negative RSDS differential data input. Channel R1(Back)
15	BR1P	Positive RSDS differential data input. Channel R1(Back)
16	BR2N	Negative RSDS differential data input. Channel R2(Back)
17	BR2P	Positive RSDS differential data input. Channel R2(Back)
18	GND	Ground
19	BCKN	Negative RSDS differential clock input. (Back)
20	BCKP	Positive RSDS differential clock input. (Back)
21	GND	Ground
22	BG0N	Negative RSDS differential data input. Channel G0(Back)
23	BG0P	Positive RSDS differential data input. Channel G0(Back)
24	BG1N	Negative RSDS differential data input. Channel G1(Back)
25	BG1P	Positive RSDS differential data input. Channel G1(Back)
26	BG2N	Negative RSDS differential data input. Channel G2(Back)
27	BG2P	Positive RSDS differential data input. Channel G2(Back)
28	GND	Ground
29	BB0N	Negative RSDS differential data input. Channel B0(Back)
30	BB0P	Positive RSDS differential data input. Channel B0(Back)
31	BB1N	Negative RSDS differential data input. Channel B1(Back)
32	BB1P	Positive RSDS differential data input. Channel B1(Back)
33	BB2N	Negative RSDS differential data input. Channel B2(Back)
34	BB2P	Positive RSDS differential data input. Channel B2(Back)
35	GND	Ground
36	GND	Ground

(2)CN1 (Panel Interface)

Pin	Name	Description
1	VDD	Driver Logic Input Voltage
2	VDD	Driver Logic Input Voltage
3	XAO	When /XAO input pin is low, all the Gate driver output pins are forced to VGH level. Note that this pin has higher priority than OE.
4	STV	Gate driver start pulse is read at the rising edge of CKV and a scan signal is output from the gate driver output pin.
5	CKV	Gate driver shift clock
6	OE	This pin is used to control the Gate driver output. When OE input is "H", gate driver output is fixed to VGL level regardless CKV.
7	GND	Ground
8	FR0N	Negative RSDS differential data input. Channel R0(Front)
9	FR0P	Positive RSDS differential data input. Channel R0(Front)
10	FR1N	Negative RSDS differential data input. Channel R1(Front)
11	FR1P	Positive RSDS differential data input. Channel R1(Front)
12	FR2N	Negative RSDS differential data input. Channel R2(Front)
13	FR2P	Positive RSDS differential data input. Channel R2(Front)
14	GND	Ground
15	POL	Data driver polarity inverting input
16	STB	The contents of the data driver register are transferred to the latch circuit at the rising edge of STB. Then the gray scale voltage is output from the device at the falling edge of STB.
17	GND	Ground
18	FCKN	Negative RSDS differential clock input. (Front)
19	FCKP	Positive RSDS differential clock input. (Front)
20	GND	Ground
21	FG0N	Negative RSDS differential data input. Channel G0(Front)
22	FG0P	Positive RSDS differential data input. Channel G0(Front)
23	FG1N	Negative RSDS differential data input. Channel G1(Front)
24	FG1P	Positive RSDS differential data input. Channel G1(Front)
25	FG2N	Negative RSDS differential data input. Channel G2(Front)
26	FG2P	Positive RSDS differential data input. Channel G2(Front)
27	GND	Ground
28	FB0N	Negative RSDS differential data input. Channel B0(Front)
29	FB0P	Positive RSDS differential data input. Channel B0(Front)
30	FB1N	Negative RSDS differential data input. Channel B1(Front)
31	FB1P	Positive RSDS differential data input. Channel B1(Front)
32	FB2N	Negative RSDS differential data input. Channel B2(Front)
33	FB2P	Positive RSDS differential data input. Channel B2(Front)
34	FSTHI	Data driver start pulse input(Front)
35	GND	Ground
36	GND	Ground

Note (1) Connector Part No.: IL-FHR-F36S-HF.

5.2 BACKLIGHT UNIT

Pin	Symbol	Description	Remark
1	HV	High Voltage	Pink
2	LV	Low Voltage	White
1	HV	High Voltage	Blue
2	LV	Low Voltage	Black

Note (1) Connector Part No.: JST-BHSR-02VS-1 or equivalent

Note (2) User's connector Part No.: JST-SM02B-BHSS-1-TB (JST) or equivalent

5.3 COLOR DATA INPUT ASSIGNMENT

The brightness of each primary color (red, green and blue) is based on the 8-bit gray scale data input for the color. The higher the binary input, the brighter the color. The table below provides the assignment of color versus data input.

Color		Data Signal																							
		Red								Green								Blue							
		R7	R6	R5	R4	R3	R2	R1	R0	R7	R6	G5	G4	G3	G2	G1	G0	R7	R6	B5	B4	B3	B2	B1	B0
Basic Colors	Black	0	0	0	0	0	0	0	0	0	0	0	0	0	0	0	0	0	0	0	0	0	0	0	0
	Red	1	1	1	1	1	1	1	1	0	0	0	0	0	0	0	0	0	0	0	0	0	0	0	0
	Green	0	0	0	0	0	0	0	0	1	1	1	1	1	1	1	1	0	0	0	0	0	0	0	0
	Blue	0	0	0	0	0	0	0	0	0	0	0	0	0	0	0	0	1	1	1	1	1	1	1	1
	Cyan	0	0	0	0	0	0	0	0	1	1	1	1	1	1	1	1	1	1	1	1	1	1	1	1
	Magenta	1	1	1	1	1	1	1	1	0	0	0	0	0	0	0	0	1	1	1	1	1	1	1	1
	Yellow	1	1	1	1	1	1	1	1	1	1	1	1	1	1	1	1	0	0	0	0	0	0	0	0
	White	1	1	1	1	1	1	1	1	1	1	1	1	1	1	1	1	1	1	1	1	1	1	1	1
Gray Scale Of Red	Red(0) / Dark	0	0	0	0	0	0	0	0	0	0	0	0	0	0	0	0	0	0	0	0	0	0	0	0
	Red(1)	0	0	0	0	0	0	1	0	0	0	0	0	0	0	0	0	0	0	0	0	0	0	0	0
	Red(2)	0	0	0	0	0	1	0	0	0	0	0	0	0	0	0	0	0	0	0	0	0	0	0	0
	⋮	⋮	⋮	⋮	⋮	⋮	⋮	⋮	⋮	⋮	⋮	⋮	⋮	⋮	⋮	⋮	⋮	⋮	⋮	⋮	⋮	⋮	⋮	⋮	⋮
	⋮	⋮	⋮	⋮	⋮	⋮	⋮	⋮	⋮	⋮	⋮	⋮	⋮	⋮	⋮	⋮	⋮	⋮	⋮	⋮	⋮	⋮	⋮	⋮	⋮
	Red(253)	1	1	1	1	1	1	0	1	0	0	0	0	0	0	0	0	0	0	0	0	0	0	0	0
	Red(254)	1	1	1	1	1	1	1	0	0	0	0	0	0	0	0	0	0	0	0	0	0	0	0	0
	Red(255)	1	1	1	1	1	1	1	0	0	0	0	0	0	0	0	0	0	0	0	0	0	0	0	0
Gray Scale Of Green	Green(0) / Dark	0	0	0	0	0	0	0	0	0	0	0	0	0	0	0	0	0	0	0	0	0	0	0	0
	Green(1)	0	0	0	0	0	0	0	0	0	0	0	0	0	0	1	0	0	0	0	0	0	0	0	0
	Green(2)	0	0	0	0	0	0	0	0	0	0	0	0	0	1	0	0	0	0	0	0	0	0	0	0
	⋮	⋮	⋮	⋮	⋮	⋮	⋮	⋮	⋮	⋮	⋮	⋮	⋮	⋮	⋮	⋮	⋮	⋮	⋮	⋮	⋮	⋮	⋮	⋮	⋮
	⋮	⋮	⋮	⋮	⋮	⋮	⋮	⋮	⋮	⋮	⋮	⋮	⋮	⋮	⋮	⋮	⋮	⋮	⋮	⋮	⋮	⋮	⋮	⋮	⋮
	Green(253)	0	0	0	0	0	0	0	1	1	1	1	1	1	1	0	1	0	0	0	0	0	0	0	0
	Green(254)	0	0	0	0	0	0	0	1	1	1	1	1	1	1	0	0	0	0	0	0	0	0	0	0
	Green(255)	0	0	0	0	0	0	0	1	1	1	1	1	1	1	1	0	0	0	0	0	0	0	0	0
Gray Scale Of Blue	Blue(0) / Dark	0	0	0	0	0	0	0	0	0	0	0	0	0	0	0	0	0	0	0	0	0	0	0	0
	Blue(1)	0	0	0	0	0	0	0	0	0	0	0	0	0	0	0	0	0	0	0	0	0	0	0	1
	Blue(2)	0	0	0	0	0	0	0	0	0	0	0	0	0	0	0	0	0	0	0	0	0	0	1	0
	⋮	⋮	⋮	⋮	⋮	⋮	⋮	⋮	⋮	⋮	⋮	⋮	⋮	⋮	⋮	⋮	⋮	⋮	⋮	⋮	⋮	⋮	⋮	⋮	⋮
	⋮	⋮	⋮	⋮	⋮	⋮	⋮	⋮	⋮	⋮	⋮	⋮	⋮	⋮	⋮	⋮	⋮	⋮	⋮	⋮	⋮	⋮	⋮	⋮	⋮
	Blue(253)	0	0	0	0	0	0	0	0	0	0	0	0	0	0	0	1	1	1	1	1	1	1	0	1
	Blue(254)	0	0	0	0	0	0	0	0	0	0	0	0	0	0	0	1	1	1	1	1	1	1	1	0
	Blue(255)	0	0	0	0	0	0	0	0	0	0	0	0	0	0	0	1	1	1	1	1	1	1	1	1

Note (1) 0: Low Level Voltage, 1: High Level Voltage

6. INTERFACE TIMING

6.1 INPUT SIGNAL TIMING SPECIFICATIONS

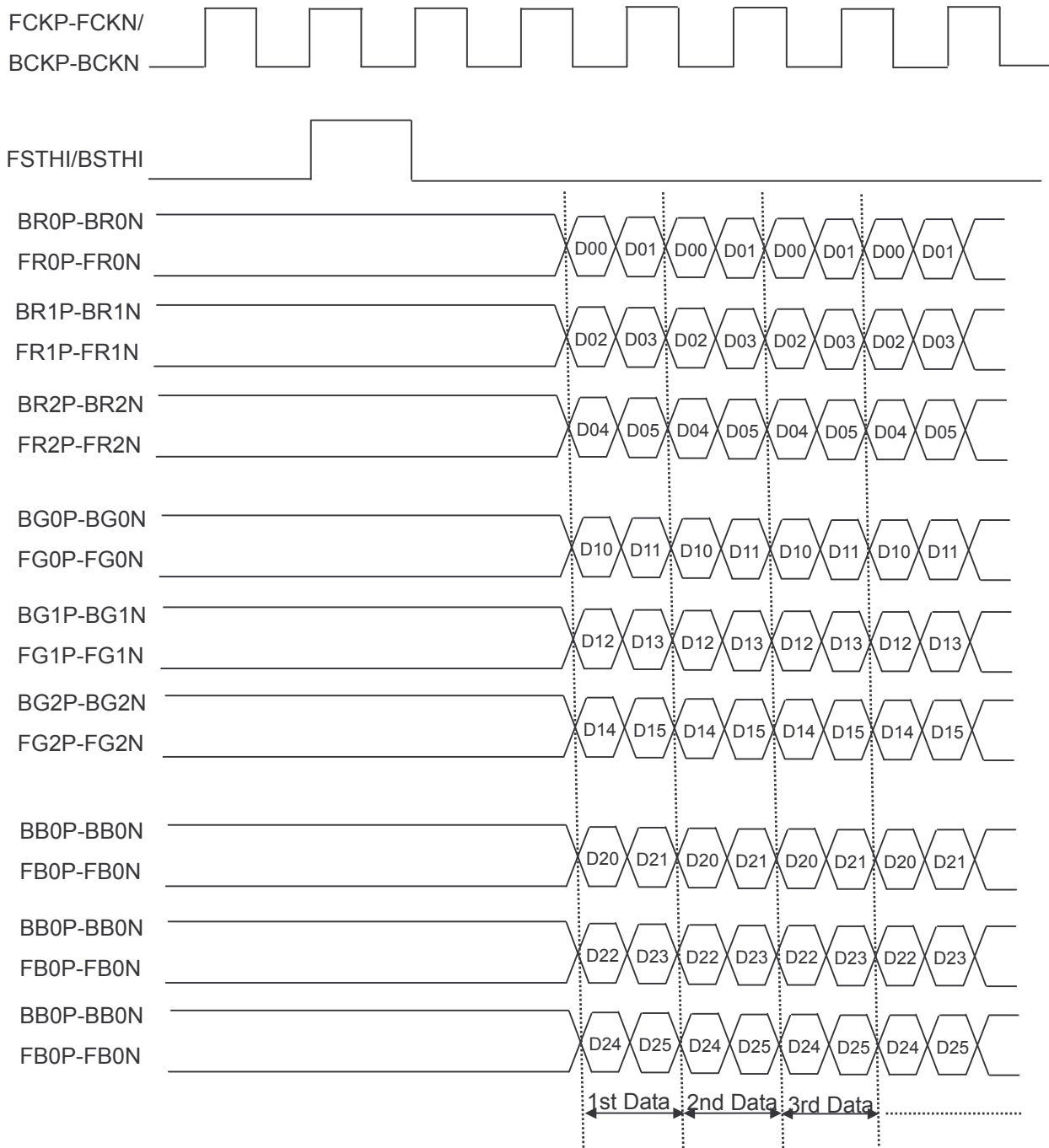

6.2 POWER ON/OFF SEQUENCE

To prevent a latch-up or DC operation of LCD module, the power on/off sequence should be as the diagram below.

Parameter	Symbol	Condition	Spec			Unit
			Min.	Typ.	Max.	
Panel On to DC/DC On	t_1	-	10	-	-	mS
DC/DC On to RSDS Data	t_2	-	40	50	60	
RSDS Data to BL_On	t_3	-	100	200	-	
RSDS Data Off to Panel Off	t_4	-	80	100	120	

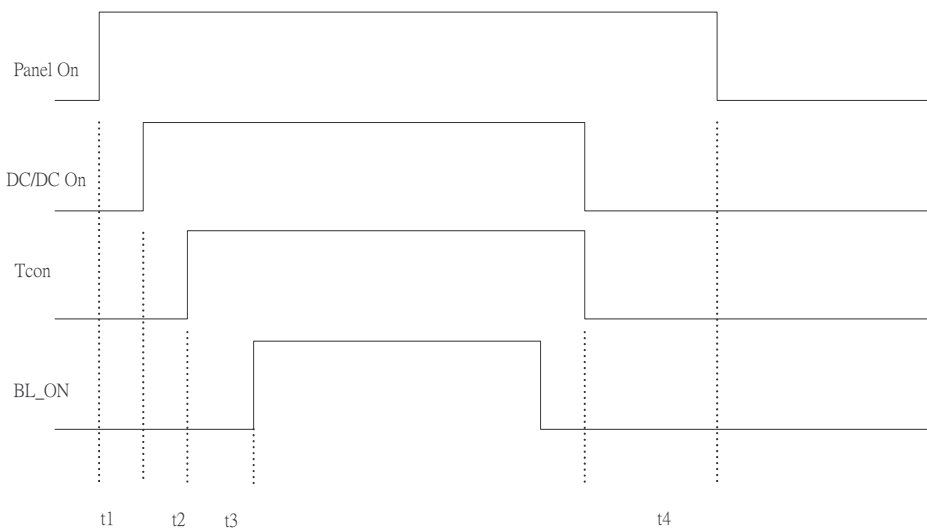

7. Driver DC Characteristics

7.1 RSDS CHARACTERISTICS

($T_a = -10$ to $+85$ °C, $V_{DD} = 2.3$ to 3.6 V, $V_{DDA} = 8.0$ to 13.5 V, $V_{SSD} = V_{SSA} = 0$ V)

Parameter	Symbol	Condition	Min.	Typ.	Max.	Unit
RSDS high input voltage	$V_{DIFFRSDS}$	$V_{CMRSDS} = +1.2$ V ⁽¹⁾	100	200	-	mV
RSDS low input voltage	$V_{DIFFRSDS}$	$V_{CMRSDS} = +1.2$ V ⁽¹⁾	-	-200	-100	mV
RSDS common mode input voltage range	V_{CMRSDS}	$V_{DIFFRSDS} = +200$ mV ⁽²⁾	$V_{SSD} + 0.1$	-	$V_{DDD} - 1.2$	V
RSDS input leakage current	IDL	DxxP, DxxN, CLKP, CLKN	-10	-	10	μA

Note: (1) $V_{CMRSDS} = (V_{CLKP} + V_{CLKN}) / 2$ or $V_{CMRSDS} = (V_{DxxP} + V_{DxxN}) / 2$

(2) $V_{DIFFRSDS} = V_{CLKP} - V_{CLKN}$ or $V_{DIFFRSDS} = V_{DxxP} - V_{DxxN}$

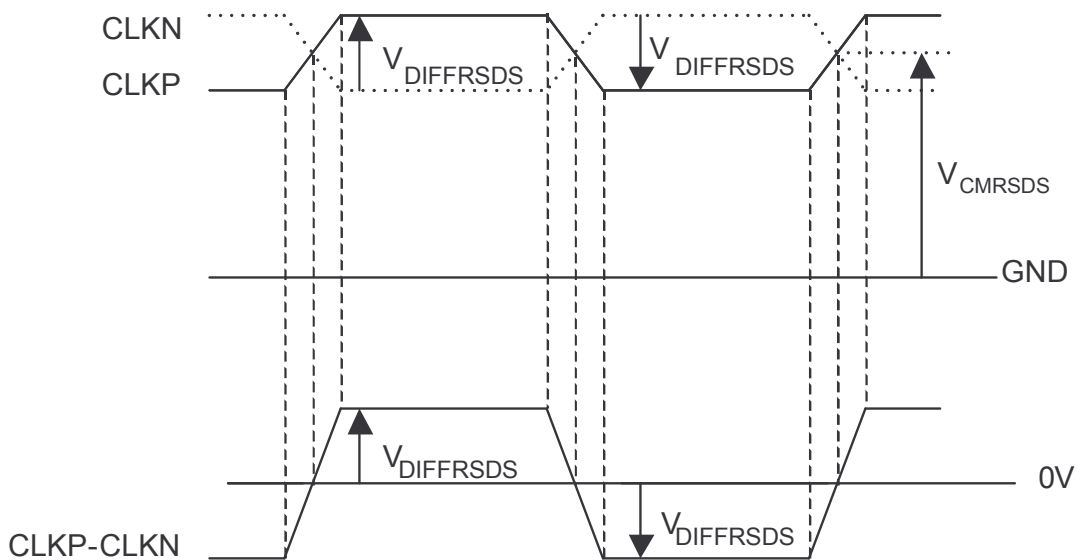

7.2 Electrical Characteristics (VSSD=VSSA=0V)

Parameter	Symbol	Condition	Spec			Unit
			Min.	Typ.	Max.	
RSDS input "Low" Voltage	$V_{DIFFRSDS}$	DX[2:0]P,DX[2:0]N, CLKP,CLKN	-	-200	-	mV
RSDS input "High" Voltage	$V_{DIFFRSDS}$		-	200	-	mV
RSDS reference voltage	V_{CMRSDS}		VSSD+0.1	1.2	VDDD-1.2	V
Input "Low" voltage	V_{IL}	EIO1,EIO2,DIR,TP1, POL	GND	-	0.2VDDD	μ A
Input "High" voltage	V_{IH}		0.8VDDD	-	VDDD	μ A
Input leak current	IL		-1	-	1	μ A
Supply current (In operation mode)	I_{CCD1}	VDDD=3.6V	-	80	- ⁽¹⁾	mA
Supply current (In operation mode)	I_{CCA1}	VDDA=13.5V	-	600	- ⁽¹⁾⁽²⁾	mA
Output current	I_{VOH}	$V_{out}=V_{\gamma 1-1V}$	-	-	-100	μ A
	I_{VOL}	$V_{out}=V_{\gamma 14+1V}$	100	-	-	μ A
Output Voltage range	V_{out}	OUT1~OUT432	VSSA+0.1	-	VDDA-0.1	V
Output Voltage deviation	$V_{cho-dev}$	VDDA=13.5V Dxx=0 to 63 Gray	-	± 5	± 10	mV
Gamma impedance	Rr	$V_{\gamma 2} \sim V_{\gamma 6}, V_{\gamma 9} \sim V_{\gamma 13}$	0.7Typ	11270	1.3Typ	Ω

 Note: (1) Test condition: TP1= 20 μ s, CLK =54MHz, data pattern =1010....checkerboard pattern, Ta=25 $^{\circ}$ C

(2) No load condition

8.Driver AC Characteristics

Parameter	Symbol	Condition	Spec			Unit
			Min.	Typ.	Max.	
Clock pulse width	t_{CLK}	-	11.8	-	-	ns
Clock pulse low period	$t_{CLK(L)}$	-	5	-	-	ns
Clock pulse high period	$t_{CLK(H)}$	-	5	-	-	ns
Data setup time	t_{SETUP1}	-	2	-	-	ns
Data hold time	t_{HOLD1}	-	0	-	-	ns
Start pulse setup time	t_{SETUP2}	-	1	-	-	ns
Start pulse hold time	t_{HOLD2}	-	2	-	-	ns
TP1 high period	$t_{TP1(H)}$	-	15	-	-	CLKP
Last data CLK to TP1 high	t_{LAST}	-	1	-	-	CLKP
TP1 high to EIO high	t_{NEXT}	-	6	-	-	CLKP
POL to TP1 setup time	$t_{POL-TP1}$	POL toggle to TP1 rising	3	-	-	ns
TP1 to POL hold time	$t_{TP1-POL}$	TP1 falling to POL toggle	2	-	-	ns

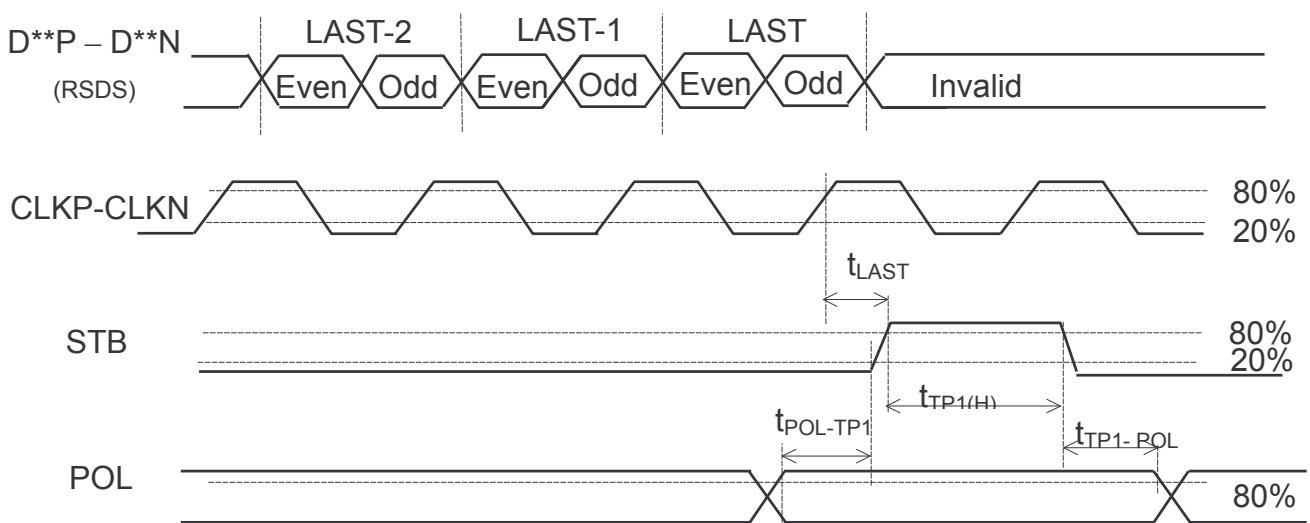
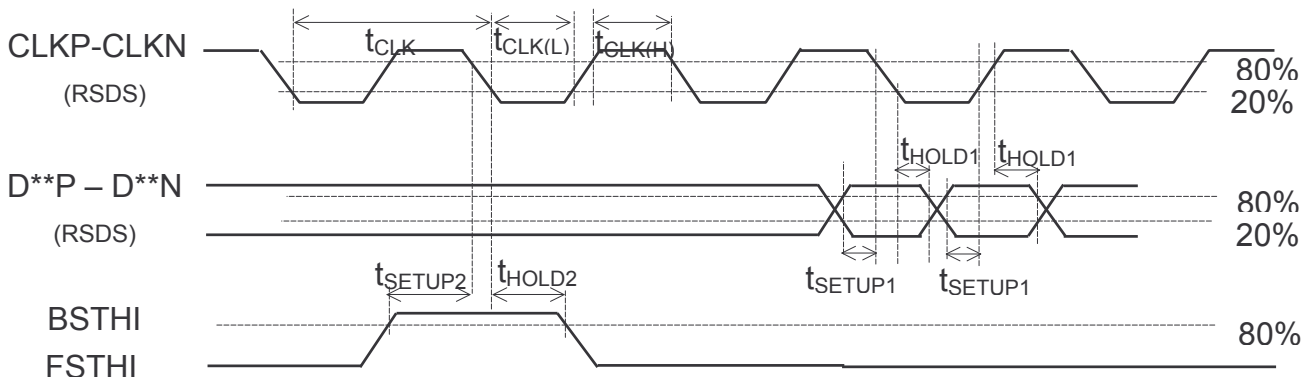

9.Vertical Timing

Parameter	Symbol	Condition	Spec			Unit	Remark
			Min.	Typ.	Max.		
CKV period	t_{CKV}	-	5	-	-	μs	
CKV pulse width	t_{CKVH}, t_{CKVL}	50% duty cycle	2.5	-	-	μs	
OE pulse width	t_{OE}	-	1	-	3.5	μs	Note2
/XAO pulse width	t_{WXAO}	-	6	-	-	μs	
Data setup time	t_{SU}	-	700	-	-	ns	
Data hold time	t_{HD}	-	700	-	-	ns	
OE to CKV time	t_{OE-CKV}			0.5		μs	
STB to CKV	$t_{STB-CKV}$		0	0	0	μs	
STB Pulse Width	t_{STB}			0.5		μs	
CKV to GVOFF	$t_{CKV-GVOFF}$			-0.5		μs	
GVOFF Pulse width	t_{GVOFF}			12.8		μs	Note1

Note 1:GVOFF,OE,STB frequency same as CKV

Note 2:Width of OE pulse should be according to vertical frequency.

Ex:2.4 μs with 75Hz V-Sync ; 3.0 μs with 60Hz V-Sync.

Note 3 : GVOFF is used to make 3-step wave form to avoid V-Through on panel.

Note 4 : OE is used to control VGH_P output to panel. When OE is "H" , VGH_P output to panel is fixed to "L" regardless CKV.

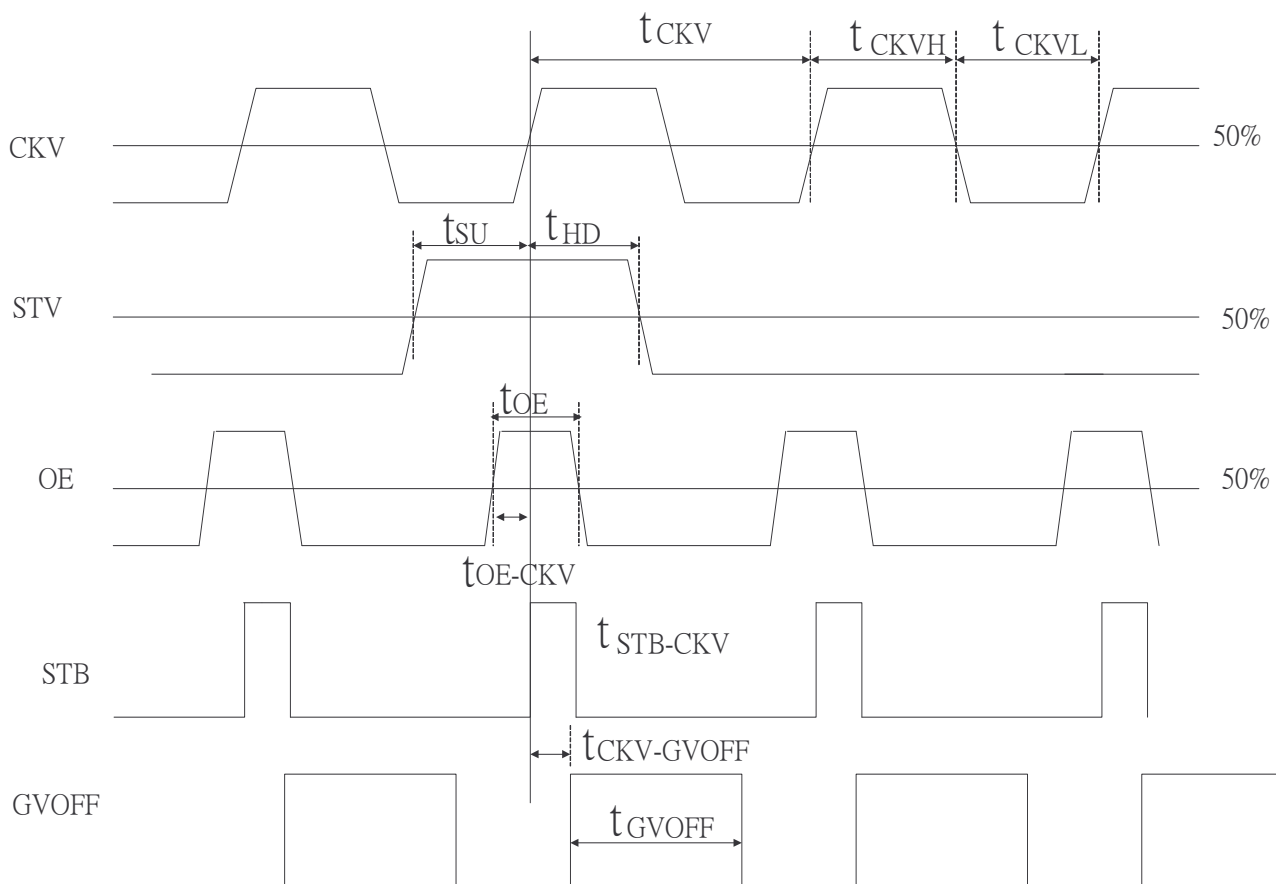

10. OPTICAL CHARACTERISTICS

10.1 TEST CONDITIONS

Item	Symbol	Value	Unit
Ambient Temperature	Ta	25±2	°C
Ambient Humidity	Ha	50±10	%RH
Supply Voltage	V _{CC}	5.0	V
Input Signal	According to typical value in "3. ELECTRICAL CHARACTERISTICS"		
Inverter Current	I _L	7.0	mA
Inverter Driving Frequency	F _L	61	KHz
Inverter	SUMIDA H05 5307		

10.2 OPTICAL SPECIFICATIONS

The relative measurement methods of optical characteristics are shown in 7.2. The following items should be measured under the test conditions described in 7.1 and stable environment shown in Note (6).

Item	Symbol	Condition	Min.	Typ.	Max.	Unit	Note	
Color Chromaticity	Red	Rx	Typ - 0.03	0.640	Typ + 0.03		(1), (5)	
		Ry		0.333				
	Green	Gx		0.285				
		Gy		0.602				
	Blue	Bx		0.152				
		By		0.074				
	White	Wx		0.313				
		Wy		0.329				
Center Luminance of White	L _C		200	280	---	cd/m ²	(4), (5)	
Contrast Ratio	CR		450	700	---	-	(2), (6)	
Response Time	T _R	θ _x =0°, θ _y =0°	---	2	7	ms	(3)	
	T _F		---	3	8	ms		
White Variation	δW	θ _x =0°, θ _y =0°	---	1.3	1.5	-	(5), (6)	
Viewing Angle	Horizontal	θ _{x+}	CR>10	75	85	---	Deg.	(1), (5)
		θ _{x-}		75	85	---		
	Vertical	θ _{y+}		70	80	---		
		θ _{y-}		70	80	---		

Note (1) Definition of Viewing Angle (θ_x, θ_y):

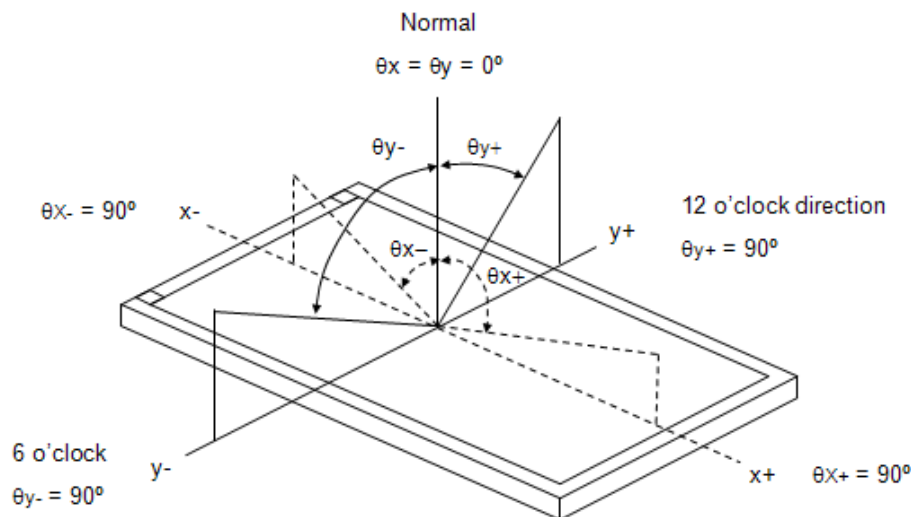

Note (2) Definition of Contrast Ratio (CR):

The contrast ratio can be calculated by the following expression.

$$\text{Contrast Ratio (CR)} = L_{255} / L_0$$

L255: Luminance of gray level 255

L 0: Luminance of gray level 0

$$\text{CR} = \text{CR (7)}$$

CR (X) is corresponding to the Contrast Ratio of the point X at Figure in Note (6).

Note (3) Definition of Response Time (T_R , T_F):

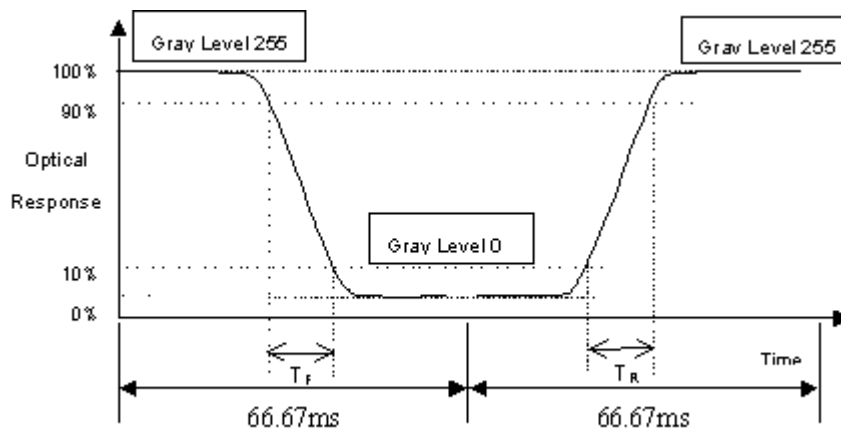

Note (4) Definition of Luminance of White (L_C):

Measure the luminance of gray level 255 at center point

$$L_C = L (7)$$

L (x) is corresponding to the luminance of the point X at Figure in Note (6).

Note (5) Measurement Setup:

The LCD module should be stabilized at given temperature for 20 minutes to avoid abrupt temperature change during measuring. In order to stabilize the luminance, the measurement should be executed after lighting Backlight for 20 minutes in a windless room.

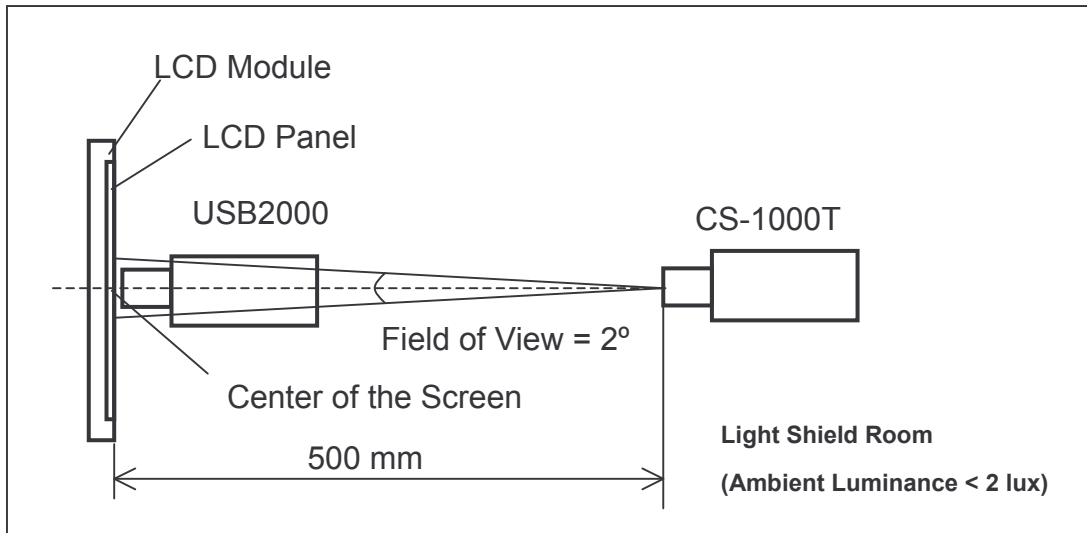
Note (6) Definition of White Variation (δW):

Measure the luminance of gray level 255 at 13 points

$$\delta W = \text{Maximum [L (1) ~ L (13)]} / \text{Minimum [L (1) ~ L (13)]}$$

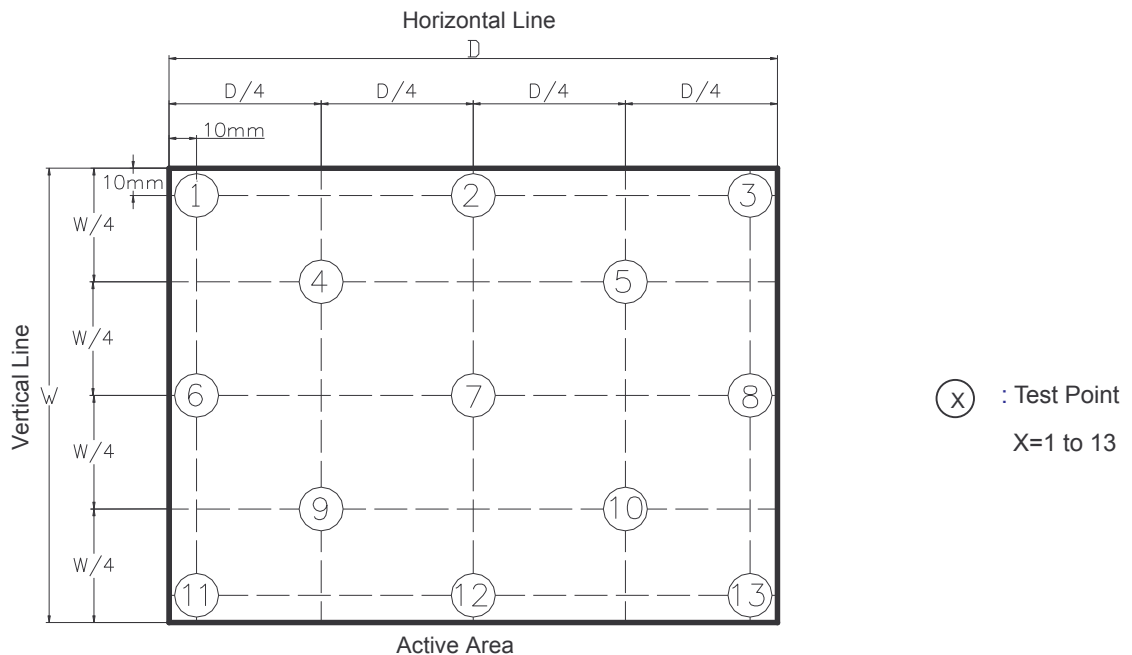

11. PACKAGING

11.1 PACKING SPECIFICATIONS

- (1) 6 LCD modules / 1 Box
- (2) Box dimensions: 595(L) X 330 (W) X 440 (H) mm
- (3) Weight: 19.2 Kg (6 modules per box)

11.2 PACKING METHOD

- (1) Carton Packing should have no failure in the following reliability test items.

Test Item	Test Conditions	Note
Vibration	ISTA STANDARD Random, Frequency Range: 1 – 200 Hz Top & Bottom: 30 minutes (+Z), 10 min (-Z), Right & Left: 10 minutes (X) Back & Forth 10 minutes (Y)	Non Operation
Dropping Test	1 Angle, 3 Edge, 6 Face, 60cm	Non Operation

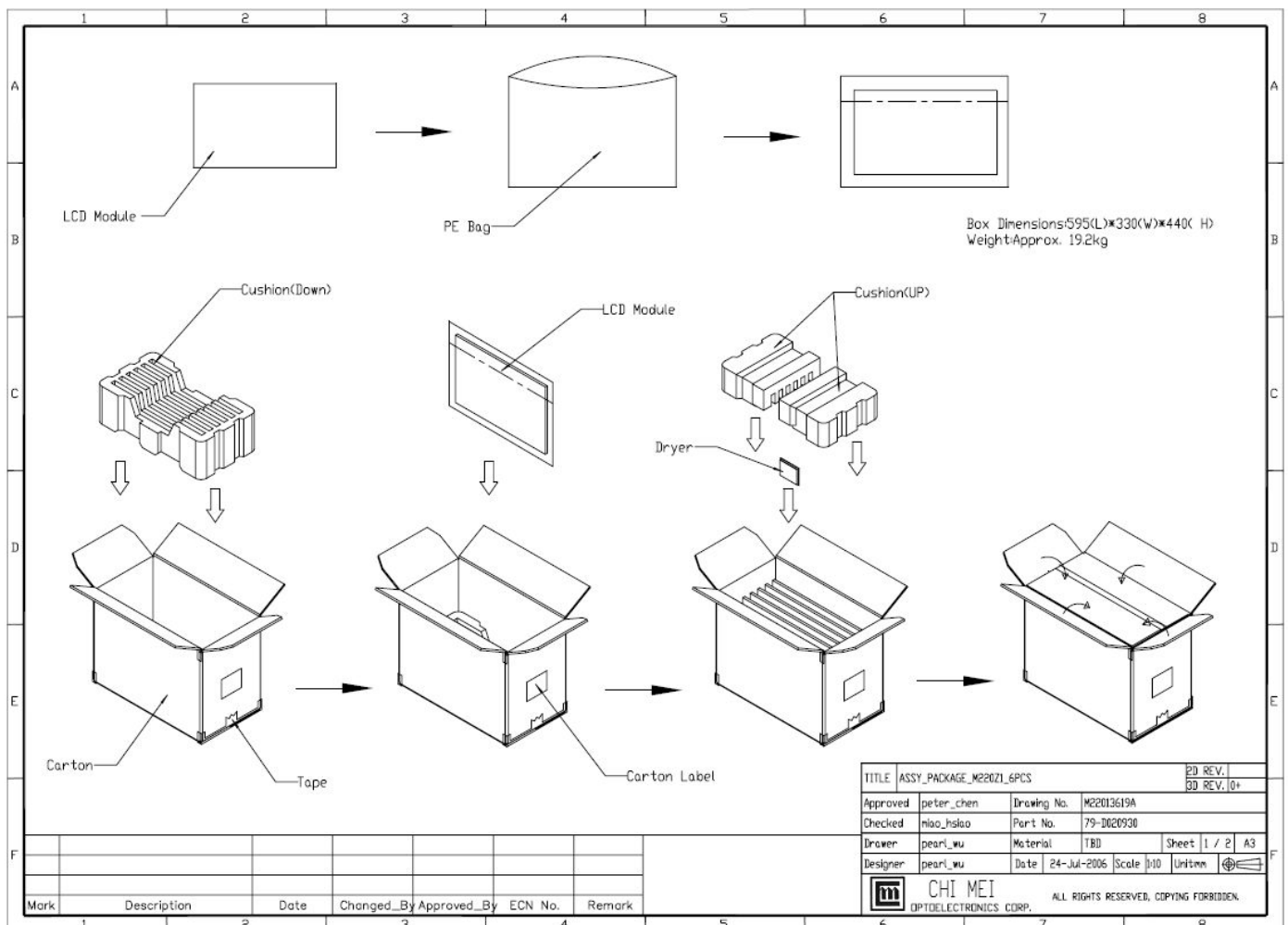

By sea

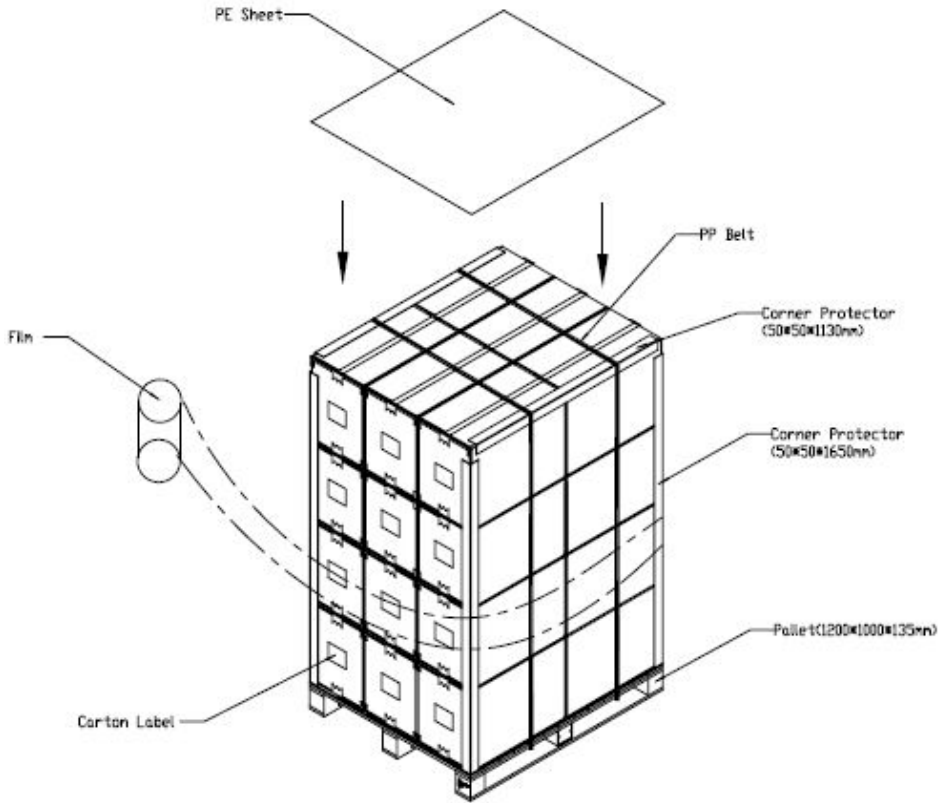

By air

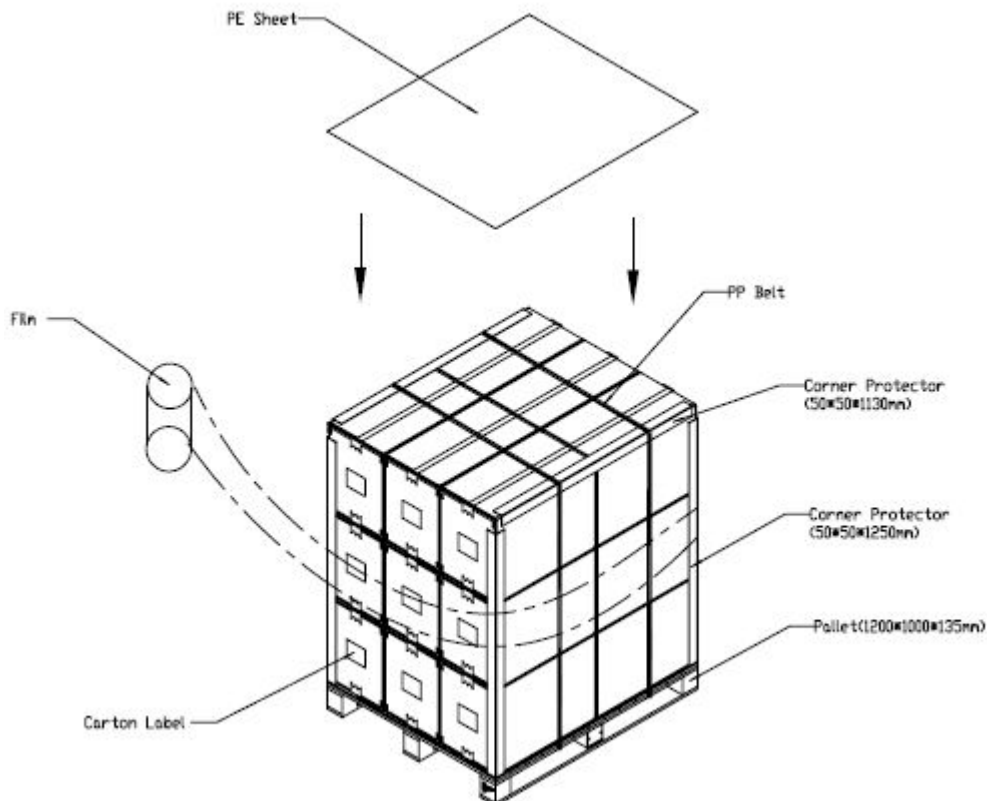

12. DEFINITION OF LABELS

12.1 CMO MODULE LABEL

The barcode nameplate is pasted on each module as illustration, and its definitions are as following explanation.

(a) GP label:



(b) S/N label:



1. Model Name: A220Z1-001
2. Revision: Rev. XX, for example: A0, A1... B1, B2... or C1, C2...etc.
3. CMO barcode definition:

Serial ID: XX-XX-X-XX-XXX-X-XXXX

Code	Meaning	Description
XX	CMO internal use	-
XX	Revision	Cover all the change
X	CMO internal use	-
XX	CMO internal use	-
XXX	Year, month, day	Year: 2001=1, 2002=2, 2003=3, 2004=4... Month: 1~12=1, 2, 3, ~, 9, A, B, C Day: 1~31=1, 2, 3, ~, 9, A, B, C, ~, W, X, Y, exclude I, O, and U.
X	Product line #	Line 1=1, Line 2=2, Line 3=3, ...
XXXX	Serial number	Manufacturing sequence of product

13. PRECAUTIONS

13.1 ASSEMBLY AND HANDLING PRECAUTIONS

- (1) Do not apply rough force such as bending or twisting to the module during assembly.
- (2) To assemble or install module into user's system can be only in clean working areas. The dust and oil may cause electrical short or worsen the polarizer.
- (3) It's not permitted to have pressure or impulse on the module because the LCD panel and Backlight will be damaged.
- (4) Always follow the correct power sequence when LCD module is connecting and operating. This can prevent damage to the CMOS LSI chips during latch-up.
- (5) Do not pull the I/F connector in or out while the module is operating.
- (6) Do not disassemble the module.
- (7) Use a soft dry cloth without chemicals for cleaning, because the surface of polarizer is very soft and easily scratched.
- (8) It is dangerous that moisture come into or contacted the LCD module, because moisture may damage LCD module when it is operating.
- (9) High temperature or humidity may reduce the performance of module. Please store LCD module within the specified storage conditions.
- (10) When ambient temperature is lower than 10°C may reduce the display quality. For example, the response time will become slowly, and the starting voltage of CCFL will be higher than room temperature.

13.2 SAFETY PRECAUTIONS

- (1) The startup voltage of Backlight is approximately 1000 Volts. It may cause electrical shock while assembling with inverter. Do not disassemble the module or insert anything into the Backlight unit.
- (2) If the liquid crystal material leaks from the panel, it should be kept away from the eyes or mouth. In case of contact with hands, skin or clothes, it has to be washed away thoroughly with soap.
- (3) After the module's end of life, it is not harmful in case of normal operation and storage.

14. MECHANICAL CHARACTERISTICS

