



6950/2039*

SUPER-POWER SHIELDED-GRID BEAM TRIODE

Double-Ended Coaxial-
Electrode Structure
Ceramic-Metal Seals

For Grid-Driven Plate-Pulsed RF
Power Amplifier Service
1500 Kw Useful Peak Power
Output at 200 Mc

Integral Water Ducts
37.24" Max. Length
20.50" Max. Diameter

RCA-6950 is a water-cooled, shielded-grid beam triode of unique design intended for use as a plate-pulsed rf power amplifier. It is especially suited for use in long-range search-radar and in particle-accelerator service. In such service, the 6950 can provide a useful peak power output of 1500 kilowatts at 200 Mc.

The 6950 can be operated with maximum ratings at frequencies up to 200 Mc and with reduced ratings to higher frequencies. The capabilities of the 6950 for operation at higher frequencies and at higher powers have not yet been completely determined, but requests for information on specific applications will be welcomed.

Design features of the 6950 include its double-ended configuration which makes possible an extended operating frequency range in comparison with that of an equivalent single-ended tube, as described in Reference 1; shielded-grid construction which permits separation of the rf input and rf output circuits and makes feasible grid-drive operation at very-high frequencies; rf electrode terminals insulated from each other by low-loss ceramic bushings which are extremely strong mechanically; large-area terminals with radial compression seals so that rf currents to the active portions of the tube flow exclusively on low-loss copper surfaces; internal ducts for water cooling the plate and beam-forming cylinder; hose couplings with simplified connections; a symmetrical array of unit electron-optical systems embodying a mechanical structure which permits close spacing and accurate alignment of the electrodes to a degree unusual in high-power tubes; and a multistrand thoriated-tungsten filament for economical operation, high emission capability, and long life.

The capabilities of the generic design of the 6950 for cw applications have not yet been completely determined, but a useful cw power output of about 500 kilowatts at 425 kc may be expected. Requests for information on a cw version of the 6950 are invited.

RCA-6950 is supplied in accordance with the RCA-6950 Acceptance Specification in effect at the time of purchase.

GENERAL DATA

Electrical:

Filament[†], Multistrand Thoriated Tungsten:

Voltage (Single-Phase AC or DC) ^{††}	{ 7.3 min.	volts
Current at 7.3 volts	{ 7.8 max.	volts
	1140	amp

* RCA Commercial Designation for Dev. Type A-2342.

Starting Current	Must never exceed 1700 amperes, even momentarily	
Cold Resistance	0.0007	ohm
Minimum time to reach normal operating voltage.	30	seconds
Minimum heating time at normal operating filament voltage before plate voltage is applied.	30	seconds
Amplification Factor, for dc grid voltage of -50 volts and dc plate voltage adjusted to give dc plate current of 10 amperes	57	
Direct Interelectrode Capacitances:		
Grid to plate	12	$\mu\mu\text{f}$
Grid to filament.	1400	$\mu\mu\text{f}$
Plate to filament	160	$\mu\mu\text{f}$

Mechanical:

Operating Position.	Vertical, with filament terminal down
Maximum Overall Length.	37.24"
Maximum Diameter.	20.50"
Terminal Connections.	See <i>Dimensional Outline</i>

Air Cooling:

It is important that the temperature of any external part of the tube should not exceed 150° C. In general, forced-air cooling of the ceramic bushings will not be required unless the 6950 is used in cavity-type circuits or in a confined space without free circulation of air. Under such conditions, provision should be made for blowing an adequate quantity of air at the ceramic bushings to limit their temperature to 150° C. Forced-air cooling of the upper and lower rf-output-return cathode terminals (K_H and K_L shown on *Tube Symbol and Dimensional Outline*) may be necessary to prevent exceeding the maximum temperature rating of 150° C, particularly at vhf frequencies.

Water Cooling:

Water cooling of the beam-forming cylinder, each grid-terminal connector, and the plate is required. The water flow must start before application of any voltages and preferably should continue for several minutes after removal of all voltages. Interlocking of the water flow for each of the cooled elements with all power supplies is recommended to prevent tube damage in case of failure of adequate water flow. The use of high-quality water is essential (see text).

Water Flow:

	Absolute Min. Flow	Typical Flow	Pressure Drop for Typical Flow	Max. Gauge Pres- sure
	gpm	gpm	psi	psi
To plate (in direction shown on <i>Dimensional Outline</i>):				
For average plate dissipation of 150 kw	80	88	40	100
To beam-forming cylinder.	7	8	12	50
Outlet Water Temperature (Any outlet)			70 max.	°C
Min. Plate-Water-Column Resistance at 25° C		1/2 megohm	per kv of peak pulse plate voltage	
Ceramic-Bushing Temperature			150 max.	°C
Metal-Surface Temperature			100 max.	°C
Weight (Approx.).			204	lbs

Fittings:

Fittings for the plate and beam-forming-cylinder water connections may be obtained from suppliers indicated under *Dimensional Outline*.

PLATE-PULSED RF POWER AMPLIFIER

Maximum Ratings, Absolute-Maximum Values for Altitudes up to 5000 feet:

For a maximum "ON" time† of 2500 microseconds during any 40000-microsecond interval

PEAK POSITIVE-PULSE PLATE SUPPLY VOLTAGE‡	40000 max.	volts
DC GRID VOLTAGE	-1000 max.	volts
PEAK PLATE CURRENT FROM PULSE SUPPLY.	92 max.	amp
PEAK RECTIFIED GRID CURRENT	5 max.	amp
DC PLATE CURRENT.	5.7 max.	amp
DC GRID CURRENT	0.3 max.	amp
PLATE INPUT (AVERAGE)	230000 max.	watts
PLATE DISSIPATION (AVERAGE)	150000 max.	watts

**Typical Operation at 200 Mc with Rectangular-
Waveshape Pulses:**

With duty factor § of 0.05

Peak Positive-Pulse Plate Supply Voltage	30000	volts
DC Grid Voltage	-250	volts
Peak RF Grid Voltage	2250	volts
Peak Plate Current from Pulse Supply	90	amp
Peak Rectified Grid Current	2	amp
DC Plate Current	4.5	amp
DC Grid Current	0.10	amp
Peak Driver Power Output (Approx.)	100000	watts
Useful Power Output at Peak of Pulse	1500000	watts

CHARACTERISTICS RANGE VALUES FOR EQUIPMENT DESIGN

	<i>Note</i>	<i>Min.</i>	<i>Max.</i>	
Filament Current	1	1060	1220	amp
Amplification Factor	1,2	46	68	
Direct Interelectrode Capacitances:				
Grid to plate	-	-	'18	μμf
Grid to filament	-	1200	1680	μμf
Plate to filament	-	144	184	μμf

Note 1: With 7.3 volts ac on filament.

Note 2: For dc grid voltage of -50 volts and dc plate voltage adjusted to give dc plate current of 10 amperes.

¶ Tube life can be conserved by operating the filament at the lowest power that will enable the tube to provide the desired power output. To determine filament power, it is necessary that both filament current and filament voltage be monitored. Meters should be adequately shielded from extraneous magnetic fields which may affect the reading. The maximum filament voltage specified in the tabulated data provides emission in excess of any requirements within tube ratings. Therefore, the filament power must be reduced to a value that will give adequate but not excessive emission for any particular application. It is recommended that the filament-voltage supply be continuously adjustable over the specified filament-voltage range. Good regulation of the filament power supply is economically advantageous from the viewpoint of tube life.

¶¶ To avoid undue thermal stresses in the filament, it is recommended that the filament voltage be raised to operating value in not less than 30 seconds.

■ At tube inlets.

† "ON" time is defined as the sum of the durations of all the individual pulses which occur during a specified interval. *Pulse duration* is defined as the time interval between the two points on the pulse at which the instantaneous value is 70% of the peak value.

§ The magnitude of any spike on the plate-voltage pulse should not exceed its peak value by more than 4000 volts and the duration of any spike when measured at the peak-value level should not exceed 10% of the maximum "ON" time.

§ Duty factor is the product of pulse duration and repetition rate.

OPERATING CONSIDERATIONS

The *maximum ratings* in the tabulated data are established in accordance with the following definition of the *Absolute-Maximum Rating System* for rating electron devices.

Absolute-Maximum ratings are limiting values of operating and environmental conditions applicable to any electron device of a specified type as defined by its published data, and should not be exceeded under the worst probable conditions.

The device manufacturer chooses these values to provide acceptable serviceability of the device, taking no responsibility for equipment variations, environment variations, and the effects of changes in operating conditions due to variations in device characteristics.

The equipment manufacturer should design so that initially and throughout life no absolute-maximum value for the intended service is exceeded with any device under the worst probable operating conditions with respect to supply-voltage variation, equipment component variation, equipment control adjustment, load variation, signal variation, environmental conditions, and variations in device characteristics.

The maximum ceramic-bushing temperature of 150° C, the maximum metal-surface temperature of 100° C, the maximum outlet-water temperature of 70° C at any outlet, and the maximum gauge pressures for the water inlets are tube ratings and are to be observed in the same manner as other ratings. The temperature of the ceramic bushings and metal surfaces can conveniently be measured with temperature-sensitive paint, such as Tempilaq. The latter is made by the Tempil Corporation, 132 W. 22nd Street, New York 11, N.Y.

The serial number which identifies each individual 6950 and which should be used in any correspondence concerning the tube, is printed on the name plate as indicated on the *Dimensional Outline*. Other numbers stamped externally on the tube are for purposes of manufacturing records only.

In transportation and handling of the 6950, care should be taken to protect the tube from rough handling that would damage the bushings or other parts. Never allow the tube to rest on the exhaust-tube cover (see *Dimensional Outline*). The safety cable on the 6950 is provided to protect personnel against possible injury while hoisting the tube into its operating position, or lifting the tube therefrom. After the tube has been seated in the equipment, remove the cable and lifting plate from the tube before operating it. Save the cable and lifting plate so that they can again be fitted on the tube when it is desired to remove the tube from the equipment. In fitting the cable to the tube, tighten the cable only enough to remove slack. Fastening the cable too tight may introduce stresses in the plate ceramic bushing with immediate or delayed damage to the bushing and/or seal.

The weight of the 6950 crated for shipment is approximately 375 pounds; uncrated, approximately 204 pounds.

It is recommended that the 6950 be tested upon receipt in the equipment in which it is to be used. For recommended "break-in" treatment, see page 9. Before the tube is placed in operation, remove any foreign material adhering to it.

During storage, the 6950 should be kept in its shipping container and should be protected from moisture and extreme temperature changes. Before a 6950 is placed in storage or shipped, it should be tipped so that the water can be poured out of its cooling ducts and then should be blown free of any remaining water. Removing all water prevents the possibility of voltaic action in the ducts with resultant corrosion and also avoids the possibility of water freezing in the ducts should the surrounding temperature drop below 0° C (32° F). Care should be taken to prevent any foreign matter from entering the water-cooling connections. As a safeguard, it is recommended that during storage each of the four water-cooling connections be covered with Pliofilm, or equivalent, and then sealed.

As in the case of all large power tubes, no 6950 should remain in storage for extended periods. It should be operated in rotation with other 6950's in order to keep it free from traces of gas which may be

liberated during prolonged storage. This procedure of rotating 6950's in service will insure that only good tubes are carried in stock.

Tube cleanliness is an important consideration. As with other high-voltage equipment, it is essential that external parts of the 6950 be kept free from accumulated dirt to minimize surface leakage and the possibility of arc-over. Make it a regular practice to wipe dirt from the external parts of the tube about twice a month or more frequently if necessary to keep the tube clean.

The *mounting* used for the 6950 should hold the tube vertically with the filament terminal down. The entire weight of the tube should be supported by the filament-terminal flange. Because of the low-voltage, high-current filament, it is recommended that the socket be an integral part of the filament transformer so that the filament connectors can be kept short and the voltage drop in them minimized. The use of coaxial filament connectors is recommended to minimize the effect of magnetic fields.

Provision should be made to prevent subjecting the 6950 to appreciable vibration.

The *connector for the cylindrical terminal of the filament* should be of the spring-pressure-contact type, while the *connector for the flange terminal of the filament* may be of the clamp type. The filament connectors should make firm, large-surface contact.

Connection to the upper and lower rf-output-return cathode terminals should be made by a band-type clamp or system of fingers.

Connection to the upper rf-input-return cathode terminal (outer) and to the lower rf-input-return cathode terminal (flange) will depend on the type of cavity employed.

Connection to the cylindrical lower rf-input-return cathode terminal should be made by a band-type clamp or a system of fingers. When a clamp is used, care must be taken in tightening the clamp not to exert too much stress which might deform the copper cylinder.

Connection to the upper and the lower grid terminal should be made by suitable water-cooled connector in intimate thermal contact with the grid-terminal surface. When the connector is fastened to the surface, *screws should be inserted carefully in the tapped holes in the copper grid terminal to avoid stripping the copper threads.*

Connection to the upper and the lower rf plate terminal should be made by a band-type clamp or a system of fingers.

The *terminal connections* should be designed so that they place no undue stress on the ceramic-metal seals. When power is applied to the tube, there may be a small movement of various parts of the tube and associated circuitry due to thermal expansion. It is necessary, therefore, that the connecting leads to the terminals be flexible. The connecting leads and water hoses should be installed so that the slack does not come close to or touch the body of the tube.

When connecting or disconnecting the water hoses and the electrical connections, it is essential that no undue stress be placed on the seals. The direction of water flow as indicated on the plate water connections, and on the beam-forming-cylinder water connections must be followed.

The *water-cooling system* consists, in general, of a source of cooling water; a feed-pipe system which carries water through flexible hoses to

the beam-forming cylinder, the plate, and water-cooled connectors, as required; and provision for interlocking the water flow through each of these cooled elements with the power supplies. When the plate is at high potential above ground, the feed-pipe system should have good insulating qualities and proper design to reduce leakage current to a negligible value.

It is recommended that the water-cooling system be of the closed type utilizing distilled water. When pure distilled water is introduced into the system, it becomes contaminated by the system components. For example, in a copper-plumbing system, the presence of oxygen and carbon dioxide enhances the dissolution of copper into the system water and its subsequent deposition as copper oxide on the hot plate structure of the tube. The rate of formation of this oxide is dependent on the operating plate dissipation of the tube and the amount of copper, oxygen, and carbon dioxide in the water system. Eventually the amount of precipitated oxide may reach a magnitude such that it will thermally insulate the plate from the water and cause the plate to crack because of insufficient cooling.

It is recommended (1) that high-quality water be used to fill the system initially, (2) that provision be made for continuous regeneration (purification) of the system water, and (3) that steps be taken to eliminate insofar as possible the sources of contamination. These recommendations will prevent scale formation, corrosion, and excessive electrolysis, and thereby permit obtaining longer tube life.

A suggested method of achieving high quality of the system water is as follows:

1. Use only distilled water to fill the system. The use of distilled water avoids the introduction of organic or colloidal matter that may exist in de-ionized water.

2. To maintain high quality, continuous regeneration (purification) of the water in the system is necessary. This regeneration can be achieved by passing a portion of the flow through suitable ion exchangers and filters. A recommended regeneration loop is shown in Fig.1. Operation of the regeneration loop should be in accord with the recommendations of the manufacturer of each component with regard to pressure, temperature, and maintenance of the individual components.

3. The efficiency and life of the regeneration loop may be improved by retarding the rate of recontamination of the water by foreign matter. Pipe lines should be connected to the water tank below the water level to minimize turbulence and thus to decrease absorption of gases by the water. It is also to be noted that any contaminating gases should be excluded from the storage tank in the closed water system.

4. In order to minimize electrolysis, the plate water-column (water path between plate and ground) resistance should have a value not less than that specified in the tabulated data.

Although an accurate chemical analysis is the absolute method of checking system-water quality, a measurement of the water resistivity may be used as a guide to determine whether or not ionized contaminants are excessive. Dissolved gases, metals, and other contaminants reduce the resistivity of the water in varying amounts. Some contaminants, such as oxygen, have no direct effect while others, such as carbon dioxide, greatly reduce the resistivity. However, if the specific resistivity of the water at 25° C falls below 1 megohm-cm, it can be assumed that the

contaminants are high. Also, if the pH of the water is outside of the range from 6.8 to 7.2, the water contains contaminants.

Proper functioning of the water-cooling system is of the utmost importance. Even a momentary failure of the water flow will damage the

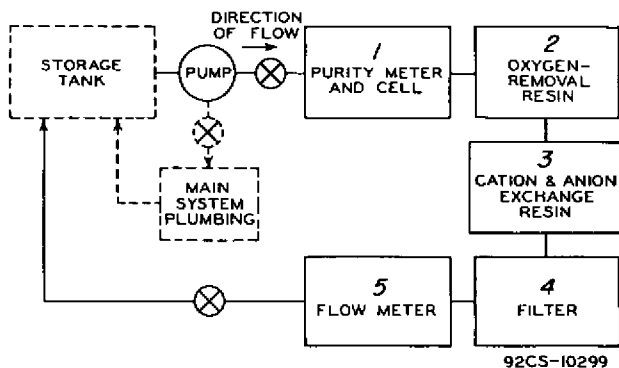

Block
No.

1. Resistivity cell (0.01 cell constant) and meter, such as Barnstead PM-18 meter with B-18 cell. This cell and meter are optional test equipment.
2. Oxygen-removal resin, such as Barnstead No.0810 cartridge, in 8D-2 Bantam Demineralizer.
3. Mixed bed demineralizer, such as Barnstead Type M Bantam Demineralizer.
4. Sub-micron filter, such as Barnstead MF-25.
5. Flow meter.

The above items may be purchased from the Barnstead Still & Sterilizer Co., 2 Lanesville Terrace, Boston 31, Mass.

Fig.1 - Block Diagram of a Water-Regeneration Loop.

given in the tabulated data. Under no circumstances should the temperature of the water from any outlet exceed 70° C.

When the tube is used in equipment under conditions such that the ambient temperature is below 0° C (32° F), precaution should be taken to prevent freezing of the water in the tube ducts after the power has been turned off.

An approximate value of the plate dissipation which should not exceed the value shown under *Maximum Ratings* in the tabulated data, may be calculated from the following equation:

$$P_{\text{watts}} = n (t_o - t_i) \times 264$$

in which t_i is the temperature of the cooling water at the inlet to plate in degrees Centigrade, t_o is the temperature of the water at the outlet from plate in degrees Centigrade, and n is the number of gallons per minute of flow.

A *time-delay relay* should be provided in the plate-supply circuit to delay application of plate voltage until the filament has reached normal operating temperature.

A *high-speed, electronic protective device* must be used to remove the plate voltage within a few microseconds in the event of abnormal operation such as internal arcing. The protective device employed to remove

6950. In fact, without cooling water, the heat of the filament alone is sufficient to destroy the tube. It is, therefore, necessary to provide a method of preventing operation of the tube in case the water supply should fail. This may be done by the use of water-flow circuit breakers or interlocks which open the power supplies when the the flow through any element is insufficient or ceases. It is essential to keep the water-flow interlocks in proper adjustment as prescribed by the equipment manufacturer. They should never be set to operate below the recommended level. The water flow must start before application of any voltages and normally should continue for several minutes after removal of all voltages. The absolute minimum water flow required through the plate for an average plate dissipation of 150 kw, and through the beam-forming cylinder, together with pressure drops is

the plate voltage in any installation must be approved by the RCA Electron Tube Division. In addition, the grid circuit should be provided with overload relays which will act to remove within a period of 0.1 second all grid power in the event of excessive grid-current flow. Inquiries concerning a high-speed, electronic protective device for removal of plate voltage from the 6950 may be addressed to Commercial Engineering, RCA, Harrison, N.J.

The *rated plate voltage of this tube is extremely dangerous*. Great care should be taken during the adjustment of circuits. The tube and its associated apparatus, especially all parts which may be at high potential above ground, should be housed in a protective enclosure. The protective housing should be designed with interlocks so that personnel cannot possibly come in contact with any high potential point in the electrical system. The interlock devices should function to break the primary circuit of the high-voltage supplies when any gate or door on the protective housing is opened, and should prevent the closing of this primary circuit until the door is again locked.

The *thoriated-tungsten filament* in the 6950 is of the multistrand type and is designed for dc or single-phase ac operation. Each individual strand is recessed in a slot in a beam-forming cylinder through which water is circulated. If the filament terminals of the tube become discolored, they should be cleaned with fine emery cloth and then wiped clean.

The filament of the 6950 must be allowed to reach normal operating temperature before plate voltage is applied. A suitable voltmeter should be permanently connected across the filament terminals directly at the tube so that the filament voltage will always be known.

For applications extremely critical as to hum, it is recommended that dc filament excitation be used.

A *filament starter* should be used to raise the filament voltage gradually (in not less than 30 seconds) in order to limit the high initial surge of current through the filament when the circuit is first closed. The starter may be either a system of time-delay relays cutting resistance or reactance out of the circuit, a high-reactance filament transformer, or an adjustable autotransformer. Regardless of the method of control, it is important that the filament current never exceed, even momentarily, a value of 1700 amperes.

The filament requires a *minimum heating time* of 30 seconds at normal operating voltage before plate voltage is applied to the 6950.

The *life of the filament can be conserved* by operating it at the lowest voltage, within its rated operating range (see General Data), which will enable the 6950 to give the desired power output. Because the filament when operated near the maximum value of 7.8 volts provides emission in excess of any requirements within tube ratings, it is recommended that the filament voltage be reduced to a value (not less than 7.3 volts) that will give adequate but not excessive emission for any particular application. Good regulation of the filament voltage is in general economically advantageous from the viewpoint of tube life.

Overheating of the 6950 by severe overload may decrease the filament emission. The filament activity can sometimes be restored by operating the filament at 7.5 volts for 30 minutes or more with no voltage on the plate or grid. This process may be accelerated by raising the filament voltage to 7.8 volts (not higher) for a few minutes. During this re-activation process, it is essential that normal water flow to the tube be maintained.

When a new circuit is tried or when adjustments are made, the plate voltage should be reduced to approximately one-half the rated value to prevent damage to the tube and associated apparatus. After correct adjustment has been made with the tube operating smoothly and without excessive heating of the cooling water or the ceramic bushings, the plate voltage may be raised in steps to the desired value. Adjustments should be made at each step for optimum operation.

At the higher frequencies, uneven heating of the seals may be encountered because of circuit arrangement. Such effects should be minimized through proper circuit design.

The following "break-in" treatment should be given to a new 6950 before it is placed in service or set aside as a spare, or to a 6950 after it has been in prolonged storage.

Step 1: Make sure that the water-cooling system and protective devices are functioning properly.

Step 2: With no other voltages on tube, apply voltage to the filament in the normal manner and operate at 7.3 volts for 15 minutes.

Step 3: Apply normal grid bias and grid drive.

Step 4: Apply approximately 50 per cent of normal plate voltage and operate the tube for several minutes until stable performance is obtained.

Step 5: Raise the plate voltage in steps if possible until the desired operating condition is achieved.

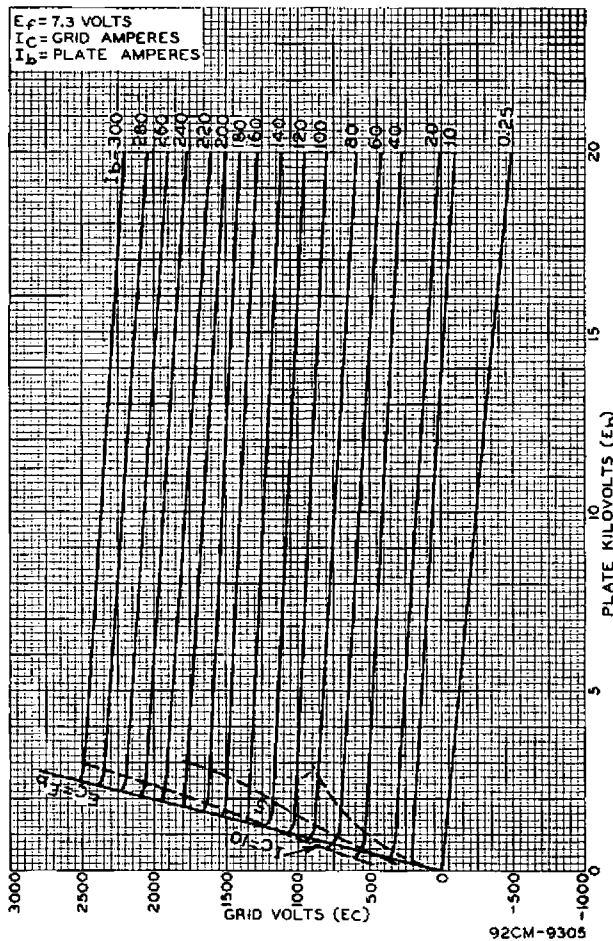

Fig. 2 - Typical Constant-Current Characteristics of Type 6950.

Caution: During this step and step 5, it is particularly important that the high-speed electronic protective device be functioning properly to protect against any abnormal condition.

Step 5: Raise the plate voltage in steps if possible until the desired operating condition is achieved.

After giving the 6950 the above treatment and after it is operating normally to give the desired output, it is suggested that the readings of the meters and flow indicators as well as the control settings be logged, especially when the tube is to be set aside as a spare. Then, in the event of an emergency tube change, the tube can be put in service quickly.

REFERENCES

1. M. V. Hoover, "*Advances in the Techniques and Applications of Very-High-Power Grid-Controlled Tubes*", Proceedings of International Convention on Microwave Valves, May, 1958, Proceedings Institution of Electrical Engineers (London), Vol. 105, Part B Suppl. No.10, 1958.
2. W. N. Parker and M. V. Hoover, "*Gas Tubes Protect High Power Transmitters*", Electronics, January, 1956.

Information furnished by RCA is believed to be accurate and reliable. However, no responsibility is assumed by RCA for its use; nor for any infringements of patents or other rights of third parties which may result from its use. No license is granted by implication or otherwise under any patent or patent rights of RCA.

TUBE SYMBOL

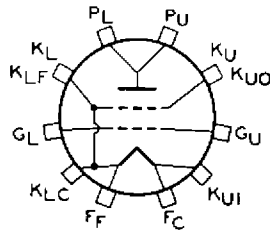

- FC : FILAMENT TERMINAL (CYLINDER)
Do Not Use for Circuit Returns
- FF : FILAMENT TERMINAL (FLANGE)
Do Not Use for Circuit Returns
- GL : LOWER GRID TERMINAL
- GU : UPPER GRID TERMINAL
- KLC: LOWER RF-INPUT-RETURN CATHODE TERMINAL (CYLINDER)
For Input-Circuit Return
- KLF: LOWER RF-INPUT-RETURN CATHODE TERMINAL (FLANGE)
For Input-Circuit Return
- KUI: UPPER RF-INPUT-RETURN CATHODE TERMINAL (INNER)
For Input-Circuit Return
- KUO: UPPER RF-INPUT-RETURN CATHODE TERMINAL (OUTER)
For Input-Circuit Return
- KL : LOWER RF-OUTPUT-RETURN CATHODE TERMINAL
For Output-Circuit Return
- KU : UPPER RF-OUTPUT-RETURN CATHODE TERMINAL
For Output-Circuit Return
- PL : LOWER RF PLATE TERMINAL
- PU : UPPER RF PLATE TERMINAL

CAUTION: DO NOT MAKE ANY DC CONNECTION BETWEEN
KUO AND KUI. SUCH A CONNECTION WILL
SHORT THE FILAMENT SUPPLY.

*For location of respective terminals,
see Dimensional Outline*

DIMENSIONAL OUTLINE

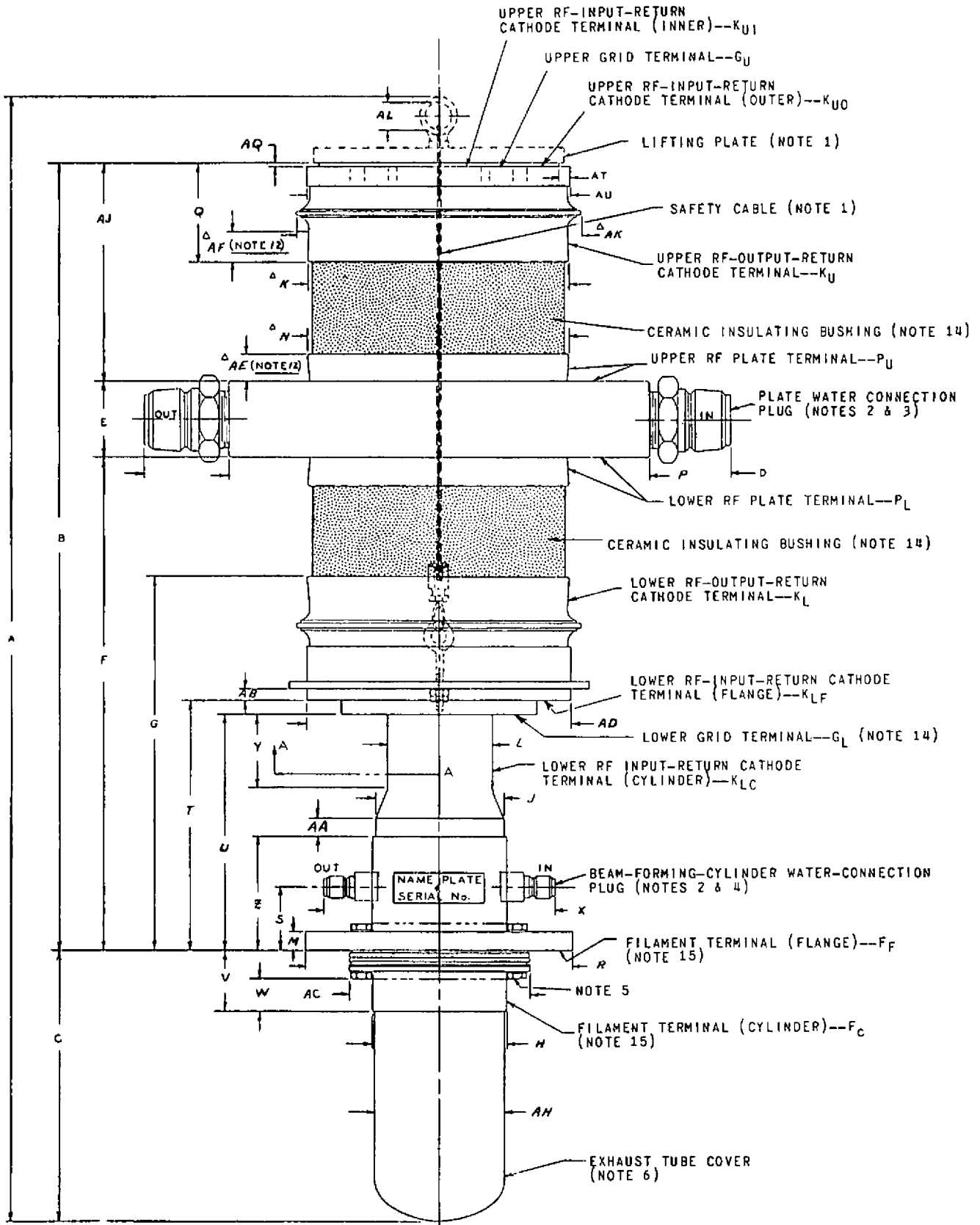

Δ - DIMENSIONS APPLY TO BOTH ENDS OF TUBE

92CS-10300R1A

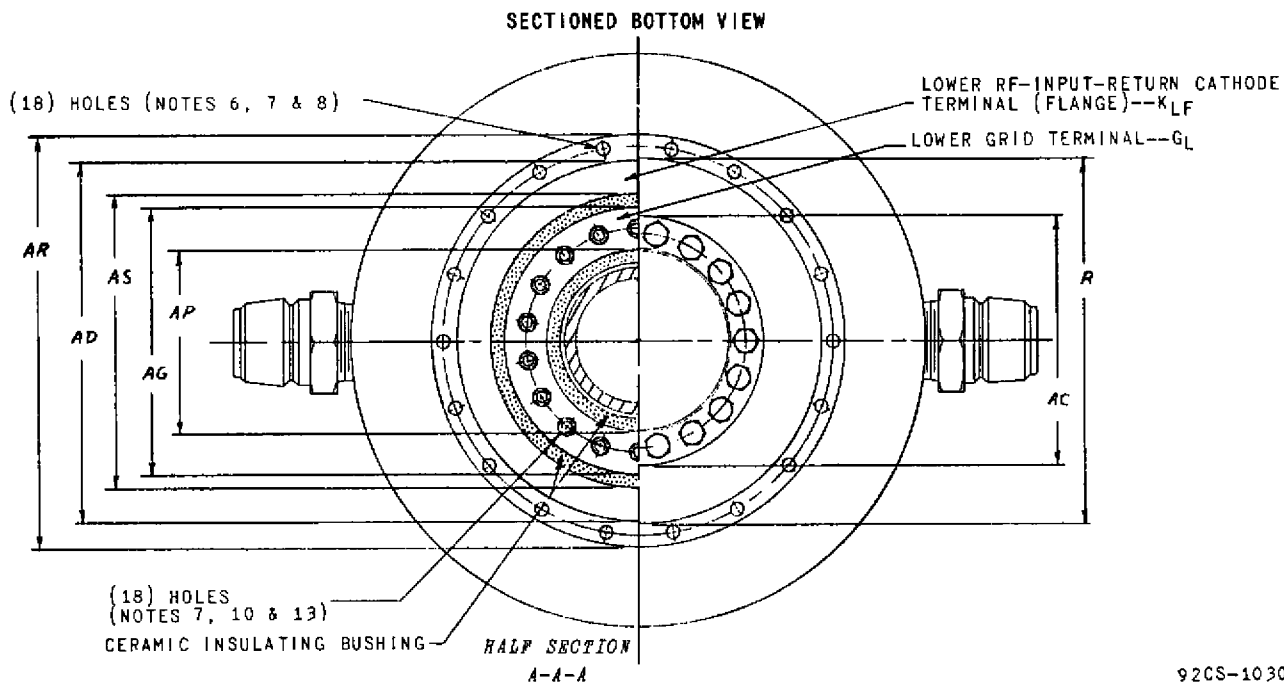
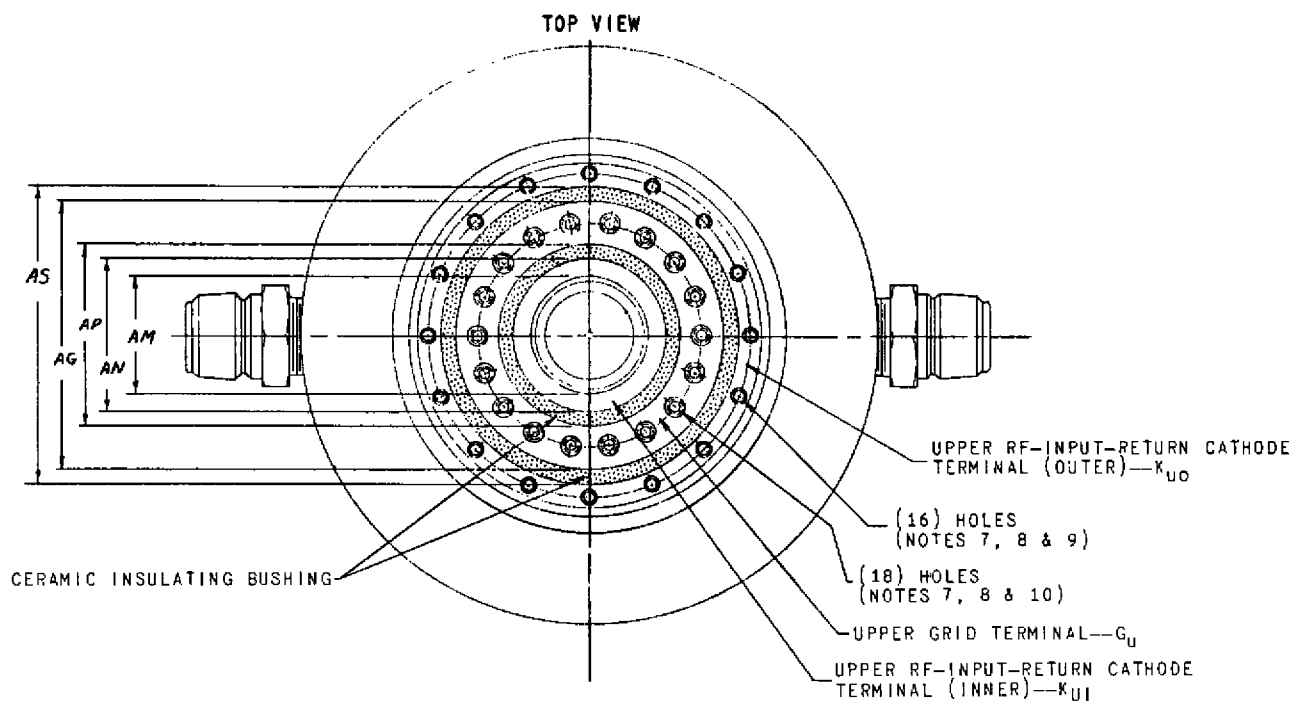

92CS-10300R1B

TABULATED DIMENSIONS FOR DIMENSIONAL OUTLINE
(All Dimensions in inches)

Dimension	Value	Dimension	Value
A	37.24 max.	AA	0.38 min.
B	25.34 ± 0.24	AB	0.38 ± 0.04
C	9.24 max.	AC	6.12 max. dia.
D	20.50 max.	AD	8.82 ± 0.06 dia.
E	2.50 ± 0.04	AE	0.88 min. (Note 12)
F	15.66 ± 0.08	AF	1 min. (Note 12)
G	11.68 ± 0.20	AG	6.56 ± 0.06 dia.
H	4.47 ± 0.03 dia.	AH	4.4 max.
J	4.34 ^{+ 0.04} - 0.06 dia.	AJ	7.18 ± 0.12
K	8.62 ± 0.10 dia.	AK	9.6 max. dia.
L	3.50 ± 0.05 dia.	AL	0.8 min.
M	0.56 ± 0.06	AM	2.82 ± 0.06 dia.
N	8.62 ± 0.10 dia.	AN	3.68 ± 0.06 dia.
P	14.12 max. dia.	AP	4.40 ± 0.10 dia.
Q	3.24 ± 0.08	AQ	0.10 ± 0.04
R	8.84 ± 0.06 dia.	AR	10.06 max. dia.
S	2.06 ± 0.12	AS	7.16 ± 0.06 dia.
T	8.38 ± 0.12	AT	0.22 min.
U	7.88 ± 0.12	AU	8.82 ± 0.06
V	1.94 ± 0.12		
W	0.8 min.		
X	8.4 max.		
Y	2 min.		
Z	3.70 ± 0.08		

NOTES FOR DIMENSIONAL OUTLINE

- Note 1:** Remove the lifting plate and safety cable before operating tube. Keep them for future tube handling.
- Note 2:** Inlet water connections (IN) are both on same side of tube and to the right when tube is viewed with name plate toward observer.
- Note 3:** This plug is removable and is Hansen No.12T45, 1-1/2". Hansen socket No.12-S46, 1-1/2" (with female pipe thread connection) fits this plug. For manufacturers's address, see Note 4.

- Note 4:** This plug is not removable and is Breco No.E4M4, 1/2". Any one of the following sockets fits this plug:
 (a) Breco No.4EF4, 1/2" (with female pipe thread connection)
 (b) Breco No.4EM4, 1/2" (with male pipe thread connection)
 (c) Hansen No.4-S25, 1/2" (with male pipe thread connection)
 (d) Hansen No.4-S26, 1/2" (with female pipe thread connection)
 (e) Hansen No.4-S27, 1/2" (with hose stem)
- Breco sockets are made by Breco Division, Perfecting Service Co., 332 Atando Ave., Charlotte 6, N.C.
- Hansen sockets are made by Hansen Manufacturing Co., 4031 West 150th Street, Cleveland, Ohio.
- Note 5:** Do not tamper with these bolts.
- Note 6:** Do not use for supporting weight of tube. Do not remove. Make no connection.
- Note 7:** Holes on different bolt circles are not indexed with respect to any other point.
- Note 8:** The planes of the upper rf-input-return cathode terminals (inner and outer) and the upper grid terminal and parallel within 0.060" and coincident within 0.090". Runout between the bolt circles of the upper terminals will be within 0.12".
- Note 9:** Sixteen (16) holes, tapped 1/4-28 NF-1B 0.31" minimum depth, equally spaced within 0.025" on a bolt-circle diameter of 7.857" \pm 0.100".
- Note 10:** Eighteen (18) holes, tapped 1/4-28 NF-1B 0.38" minimum depth, equally spaced within 0.025" on a bolt-circle diameter of 5.450" \pm 0.025".
- Note 11:** Eighteen (18) holes equally spaced within 0.025" on a bolt-circle diameter of 9.50" \pm 0.03" for 1/4"-diameter bolts.
- Note 12:** This area is subjected to a maximum taper of 0.060" to the inch. The maximum diameter along this taper will be on the end toward the ceramic.
- Note 13:** Runout between bolt circles of the lower terminals will be within 0.12".
- Note 14:** A potting compound (silicon rubber, or equivalent) has been applied in the space formed at the junction of each of the following metal terminals and its associated ceramic bushing:
- A. the upper rf-output-return cathode terminal
 - B. the upper rf plate terminal
 - C. the lower rf-output-return cathode terminal
 - D. the lower rf plate terminal
 - E. the rf-input-return cathode terminal flange
 - F. the lower grid terminal
 - G. the lower rf-input-return cathode terminal -- cylinder
 - H. the lower grid terminal
- Note 15:** Use for filament power only. Input-circuit returns should be made to the rf-input-return cathode terminals. Output-circuit returns should be made to the rf-output-return cathode terminals.