

— a3130 general features —

The a3130 is a universal DSP-based PFC solution to be used in applications requiring power factor values close to unity. Typical applications are high-power DC motors and lighting systems. The controller is based on the boost topology and is fully software-controlled. The PFC algorithm is loaded from an on-chip non-volatile memory for stand-alone operation or can be uploaded to the DSP core using a two-wire interface.

Highlights:

- Fully reconfigurable digitally-controlled power factor controller in CMOS technology
- On-chip AC-phase-locked sinusoidal 45...65Hz oscillator to improve AC-line noise rejection
- High accuracy through on-chip 10bit ADC and dedicated RISC processor
- Achievable high efficiency (>95%) and power factor (>0.99)
- Broad range of user-selectable PWM frequency (5kHz...200kHz)
- Low EMC filter requirements due to use of spread-spectrum PWM
- Two-wire interface to load software
- Supports 90V...135V and 195V...275V 60/50Hz mains standards

Available Options:

- On-chip gate driver
- On-chip OTP memory for stand-alone operation

— example application schematic —

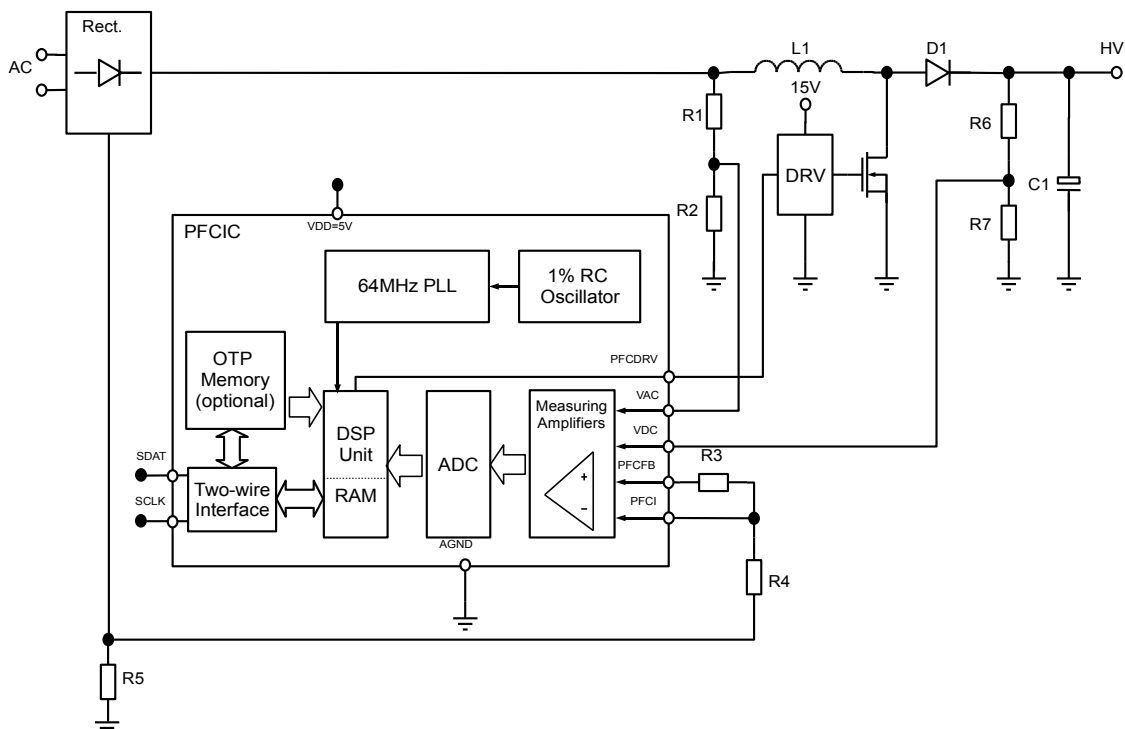

a3130: simplified application schematic