

# Low Voltage Voice Coil Motor Driver

## Features and Benefits

- Fixed I<sup>2</sup>C logic thresholds
- 8-bit D-to-A converter
- 500  $\mu$ A resolution
- Low voltage I<sup>2</sup>C serial interface
- Low current-draw sleep mode
- 2.4 to 5.5 V operation
- 2 mm  $\times$  1.5 mm, 0.38 mm nominal overall height DFN
- 1.1 mm  $\times$  0.7 mm, 0.5 mm maximum overall height WLCSP
- 1.1 mm  $\times$  0.7 mm, 0.33 mm nominal overall height bare die

## Packages:

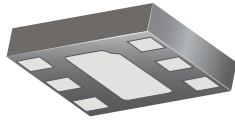

1.5 mm  $\times$  2 mm DFN  
(EW package)



1.1 mm  $\times$  0.7 mm WLCSP  
(CG package)

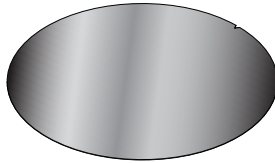

Bare die  
(CW package)

Not to scale

## Description

The A3904 is a voice coil motor (VCM) driver, with an I<sup>2</sup>C-compatible serial interface. Designed for camera autofocus and zoom applications, this high accuracy digital IC is provided in small packages ideal for portable devices. Its operating voltage range is 2.4 to 5.5 V, and its maximum output current is 127 mA.

Output current is programmed via the I<sup>2</sup>C interface, in 500  $\mu$ A increments, with clock rates up to 400 kHz. I<sup>2</sup>C inputs set the internal D-to-A converter output voltage that is the reference for linear current control via a MOSFET output sink transistor. To conserve battery power, a logic low signal on the SLEEPZ input disables the output MOSFET and reduces the supply current to  $<0.5 \mu$ A.

A3904 internal protection features include thermal shutdown and undervoltage lockout. Logic input levels are independent of the supply voltage. The operating temperature range is  $-40^{\circ}\text{C}$  to  $85^{\circ}\text{C}$ .

The A3904 is available at three packaging levels: bare die on wafer (suffix CW); bumped wafer level chip scale package (WLCSP) (suffix CG); and complete thin profile (0.38 mm nominal overall height) DFN package, with NiAuPd leadframe plating and an exposed tab for enhanced thermal dissipation (suffix EW).

## Functional Block Diagram

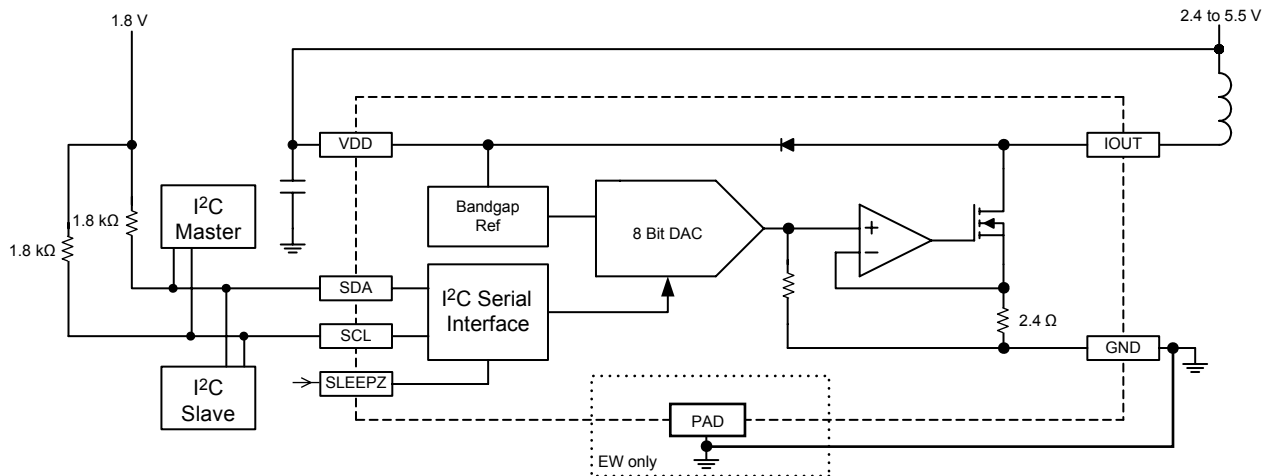

# A3904

# Low Voltage Voice Coil Motor Driver

## Selection Guide

| Part Number  | Packing              | Package                                       | Pb-Free  |
|--------------|----------------------|---|--|
| A3904ECW     | Wafer                | Bare die                                      | Yes  |
| A3904ECGTR   | 4000 pieces per reel | Bumped wafer-level chip-scale package (WLCSP) | Pb-free chip with high-temperature solder balls (RoHS compliant) |
| A3904EEWTR-P | 3000 pieces per reel | Leadless package (DFN)                        | Yes; NiAuPd leadframe plating                                    |

## Absolute Maximum Ratings

| Characteristic                | Symbol            | Notes   | Rating               | Units |
|-------------------------------|-------------------|---------|----------------------|-------|
| Supply Voltage                | $V_{DD}$          |         | 6                    | V     |
| Logic Input Voltage Range     | $V_{IN}$          |         | -0.3 to $V_{DD}+0.3$ | V     |
| Operating Ambient Temperature | $T_A$             | Range E | -40 to 85            | °C    |
| Maximum Junction Temperature  | $T_J(\text{max})$ |         | 150                  | °C    |
| Storage Temperature           | $T_{stg}$         |         | -55 to 150           | °C    |

## Thermal Characteristics

| Characteristic                                  | Symbol          | Test Conditions*                                | Rating | Units |
|---|-----------------|---|--------|-------|
| Package Thermal Resistance, Junction to Ambient | $R_{\theta JA}$ | EW package, 4-layer PCB based on JEDEC standard | 64     | °C/W  |

\*For additional information, refer to the Allegro website.

www.DataSheet4U.com

## Pin-out Diagrams

### CG Package



Orientation mark  
on ball side

### EW Package

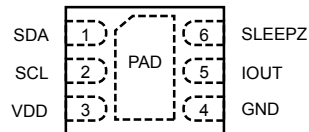

## Terminal List

| Number |    | Name   | Description                        |
|--------|----|--------|------------------------------------|
| EW     | CG |        |                                    |
| 1      | A1 | SDA    | I <sup>2</sup> C data input/output |
| 2      | A2 | SCL    | I <sup>2</sup> C clock             |
| 3      | A3 | VDD    | Power supply                       |
| 4      | B3 | GND    | Ground                             |
| 5      | B2 | IOOUT  | Sink drive output                  |
| 6      | B1 | SLEEPZ | Standby mode control               |
| PAD    | -  | -      | Exposed thermal pad (tie to GND)   |

**A3904****Low Voltage Voice Coil Motor Driver****ELECTRICAL CHARACTERISTICS** Valid at  $T_A = 25^\circ\text{C}$ ,  $V_{DD} = 2.4$  to  $5.5$  V, unless otherwise noted

| Characteristics                         | Symbol          | Test Conditions  | Min.  | Typ.    | Max.         | Units                 |
|---|-----------------|--|-------|---------|--------------|-----------------------|
| <b>General</b>                          |                 |  |       |         |              |                       |
| Supply Current                          | $I_{DD}$        |  | –     | 0.5     | 2            | mA                    |
|   |                 | Sleep mode (SLEEPZ = Low)  | –     | <100    | 500          | nA                    |
| UVLO Enable Threshold                   | $V_{UV(th)}$    | $V_{DD}$ rising  | –     | 2.1     | 2.395        | V                     |
| UVLO Hysteresis                         | $V_{UV(hys)}$   |  | 100   | –       | –            | mV                    |
| Thermal Shutdown Temperature            | $T_{JTSD}$      | Temperature increasing   | –     | 165     | –            | $^\circ\text{C}$      |
| Thermal Shutdown Hysteresis             | $T_{JTSD(hys)}$ | $T_{JTSD(hys)} = T_{JTSD} - T_{J(recover)}$                          | –     | 15      | –            | $^\circ\text{C}$      |
| Power-Up Delay                          | $t_{d(on)}$     |  | –     | 10      | –            | $\mu\text{s}$         |
| <b>D-to-A Converter</b>                 |                 |  |       |         |              |                       |
| Resolution                              | Res             | Target = 500 $\mu\text{A}$ / LSB                                     | –     | 8       | –            | bit                   |
| LSB Relative Accuracy                   | INL             | Code = 16 to 255, Endpoint method                                    | –     | $\pm 4$ | –            | LSB                   |
| LSB Differential Nonlinearity           | DNL             | Guaranteed monotonic   | –     | –       | $\pm 1$      | LSB                   |
| Maximum Output Current                  | $I_{max}$       | Code = 255   | –     | 127.5   | –            | mA                    |
| Gain Error                              | $err_A$         | $T_J = 25^\circ\text{C}$ , Code 16 to 255, $V_{DD} = 2.6$ to $3.0$ V | –10   | <3      | 10           | %FS                   |
| Gain Error Drift*                       | $\Delta err_A$  | $T_J = -40^\circ\text{C}$ to $125^\circ\text{C}$                     | –     | 0.2     | –            | LSB/ $^\circ\text{C}$ |
| Offset Error                            | $I_{errOS}$     | Code = 1   | 0     | 1       | 5            | mA                    |
|   |                 | Code = 16  | 0.5   | –       | –            | mA                    |
| <b>Output</b>                           |                 |  |       |         |              |                       |
| Output Voltage Range                    | $V_{OUT}$       |  | 0.500 | –       | $V_{DD}-0.1$ | V                     |
| Output On Resistance                    | $R_{DS(on)}$    | $R_{SENSE} + R_{SINK}$ , $I_{OUT} = 127.5$ mA                        | –     | 3       | –            | $\Omega$              |
| <b>I<sup>2</sup>C Interface</b>         |                 |  |       |         |              |                       |
| Bus Free Time Between Stop and Start    | $t_{BUF}$       |  | 1.3   | –       | –            | $\mu\text{s}$         |
| Hold Time Start Condition               | $t_{hdSTA}$     |  | 0.6   | –       | –            | $\mu\text{s}$         |
| Setup Time for Repeated Start Condition | $t_{suSTA}$     |  | 0.6   | –       | –            | $\mu\text{s}$         |
| SCL Low Time                            | $t_{LOW}$       |  | 1.3   | –       | –            | $\mu\text{s}$         |
| SCL High Time                           | $t_{HIGH}$      |  | 0.6   | –       | –            | $\mu\text{s}$         |
| Data Setup Time                         | $t_{suDAT}$     |  | 100   | –       | –            | ns                    |
| Data Hold Time                          | $t_{hdDAT}$     |  | 0     | –       | 900          | ns                    |
| Setup Time for Stop Condition           | $t_{suSTO}$     |  | 0.6   | –       | –            | $\mu\text{s}$         |
| Logic Input Low Level (SDA, SCL pins)   | $V_{IL}$        |  | –     | –       | 0.84         | V                     |
| Logic Input High Level (SDA, SCL pins)  | $V_{IH}$        |  | 1.26  | –       | –            | V                     |
| Input Hysteresis (SDA, SCL pins)        | $V_{hys}$       |  | –     | 100     | –            | mV                    |
| SLEEPZ Input Low Level                  | $V_{inSLP}$     |  | –     | –       | 0.7          | V                     |
| SLEEPZ Input High Level                 | $V_{inSLP}$     |  | 1.5   | –       | –            | V                     |
| Logic Input Current                     | $I_{IN}$        | $V_{IN} = 0$ V to $V_{DD}$   | –1    | 0       | 1            | $\mu\text{A}$         |
| Output Voltage (SDA pin)                | $V_{OL}$        | $I_{LOAD} = 1.5$ mA  | –     | –       | 0.36         | V                     |
| Clock Frequency (SCL pin)               | $f_{CLK}$       |  | –     | –       | 400          | kHz                   |
| Output Fall Time (SDA pin)              | $t_{fO}$        | $V_{IH}$ to $V_{IL}$   | –     | –       | 250          | ns                    |

\*Guaranteed by design and characterization, not production tested

# A3904

## Low Voltage Voice Coil Motor Driver

### I<sup>2</sup>C Interface Timing Diagram

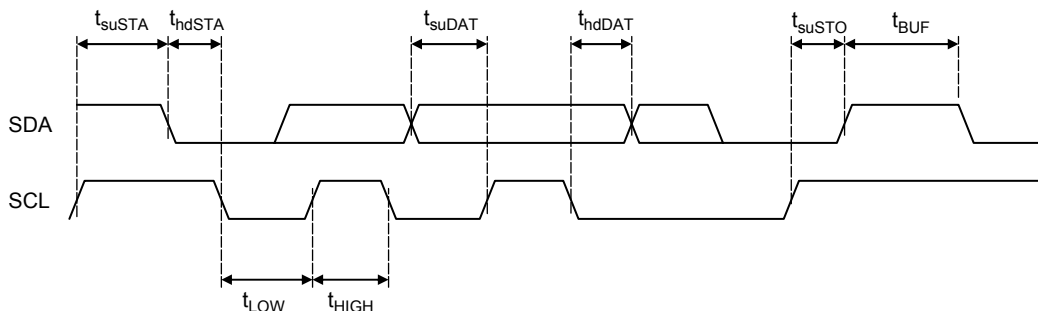

### Write Register Bit Definition and Timing Diagram

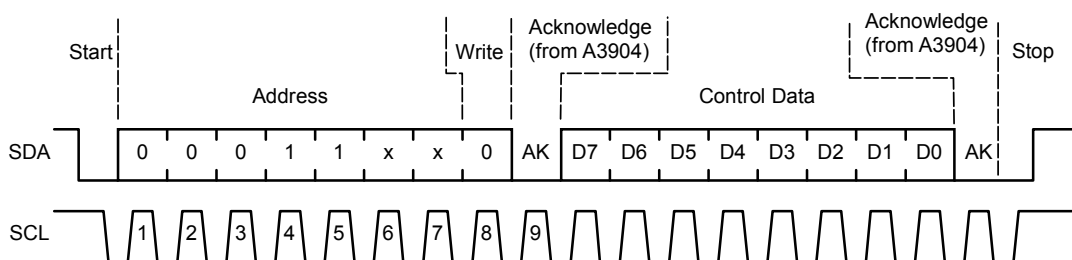

### I<sup>2</sup>C Control Register Bit Definition

| Bit | Name | Function |
|-----|------|----------|
| 0   | D0   | DAC LSB  |
| 1   | D1   |          |
| 2   | D2   |          |
| 3   | D3   |          |
| 4   | D4   |          |
| 5   | D5   |          |
| 6   | D6   |          |
| 7   | D7   | DAC MSB  |

### A3904 Slave Address Bit Definition

| Bit |   |   |   |   |   |   |   | Operation |
|-----|---|---|---|---|---|---|---|-----------|
| 0   | 1 | 2 | 3 | 4 | 5 | 6 | 7 |           |
| 0   | 0 | 0 | 1 | 1 | x | X | 1 | Read      |
| 0   | 0 | 0 | 1 | 1 | x | X | 0 | Write     |

# A3904

## Low Voltage Voice Coil Motor Driver

### Functional Description

The A3904 output current is controlled by programming the D-to-A converter value via the I<sup>2</sup>C serial port. The target output current can be calculated by:

$$I_{OUT} = DAC \times 500 \mu A ,$$

where DAC = 1 to 255. Code = 0 is a disable state for the output sink drive. The DAC will be set to code = 0 upon power-up or a fault condition on V<sub>DD</sub>.

**SLEEPZ** A logic low input disables all of the internal circuitry and prevents the IC from draining battery power.

**Output Range** The voltage on the IOUT pin should be greater than 500 mV to guarantee the accuracy and linearity of the programmed current. The output voltage is a function of the battery voltage, motor resistance, and the programmed load current.

**Clamp Diode** When the output is turned off, the load inductance causes the output voltage to rise. A clamp diode, from IOUT to VDD, is integrated in the IC to ensure that the output voltage remains at a safe level.

**I<sup>2</sup>C Interface** This is a serial interface that uses two bus lines, SCL and SDA, to access the internal Control registers. Data is exchanged between a microcontroller (master) and the A3904 (slave). The clock input to SCL is generated by the master, while the SDA line functions as either an input or an open drain output, depending on the direction of the data. The I<sup>2</sup>C input thresholds do not depend on the V<sub>DD</sub> voltage of the A3904. The levels are fixed at approximately 1 V. The fixed levels allow the SDA and SCL lines to be pulled-up to a different logic level than the V<sub>DD</sub> supply of the 3904.

**Timing Considerations** The control sequence of the communication through the I<sup>2</sup>C interface is composed of several steps

in the following sequence:

1. Start Condition. Defined by a negative edge on the SDA line, while SCL is high.
2. Address Cycle. 7 bits of address, plus 1 bit to indicate write (0) or read (1), and an acknowledge bit. The address setting is 0x18, 0x1A, 0x1C or 0x1E.
3. Data Cycles. Write 8 bits of data that address the internal Control register, followed by an acknowledge bit.
4. Stop Condition. Defined by a positive edge on the SDA line, while SCL is high.

Except to indicate a Start or Stop condition, SDA must be stable while the clock is high. SDA can only be changed while SCL is low. It is possible for the Start or Stop condition to occur at any time during a data transfer. The A3904 always responds by resetting the data transfer sequence.

The Read/Write bit is set low to indicate a write cycle. Multiple writes are allowed before issuing a Stop condition. There are no readback functions incorporated into the A3904.

The master monitors for an acknowledge pulse to determine if the slave device is responding to the address byte sent to the A3904. When the A3904 decodes the 7-bit address field as a valid address, it responds by pulling SDA low during the ninth clock cycle.

During a data write from the master, the A3904 pulls SDA low during the clock cycle that follows the data byte, in order to indicate that the data has been successfully received.

After sending either an address byte or a data byte, the master device must release the SDA line before the ninth clock cycle, in order to allow this handshaking to occur.

# A3904

## Low Voltage Voice Coil Motor Driver

### Application Information

**Headroom** The current may not reach the programmed level if there is not adequate headroom in the output circuit. The IC output voltage must be over 500 mV to guarantee normal linear operation.  $V_{DD}$ ,  $I_{LOAD}$ , and  $R_{LOAD}$  can be adjusted to ensure that the device operates in the linear range.

If the equation shown below is not satisfied, the load current will be limited by the series impedance, and may not reach the programmed level

$$V_{DD}(\min) - R_{LOAD}(\max) \times I_{OUT}(\max) \geq 500 \text{ mV} .$$

### $I_{OUT}$ Errors

**Relative accuracy (INL)** This error is calculated by measuring the worse case deviation from a straight line, defined from end points. The straight line end points are defined by the actual measured values at Code = 16 and Code = 255. See figure 1.

**Differential nonlinearity (DNL)** A measure of the monotonicity of the D-to-A converter. The slope of the line must always

be positive for each incremental step, according to the following formula:

$$DNL = (I_{OUT(n+1)} - I_{OUT(n)}) / LSB - 1 \text{ (LSB)} .$$

where  $n$  is in the range 16 to 255.

**Offset error** The measured output current at input Code = 16, compared to the ideal value according to the transfer function (8 mA).

**Gain Error** The difference in the slopes of the ideal transfer function and the actual transfer function. The gain error is calculated by subtracting out the offset error, at Code = 16, from the actual transfer function. This calculated value is compared to the ideal transfer function and reported as a percentage of the ideal full scale value (127.5 mA). See figure 2.

**Gain Error Drift** The change in slope of the transfer function due to temperature, expressed as  $LSB/^{\circ}C$ .

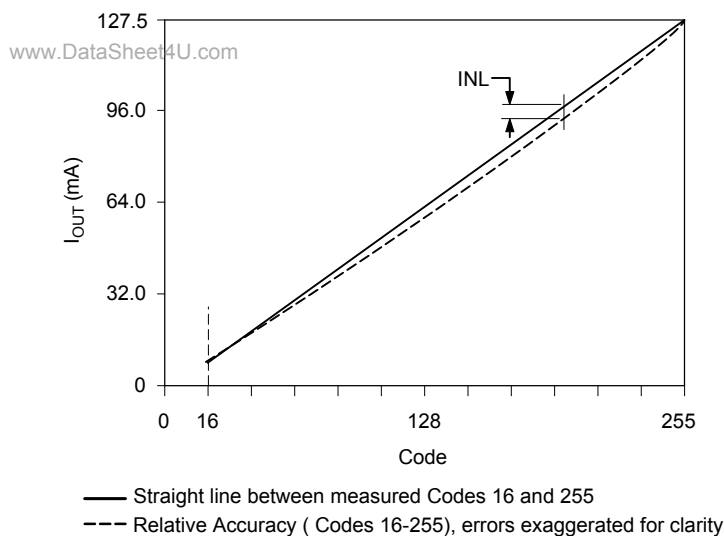

Figure 1. Relative accuracy error

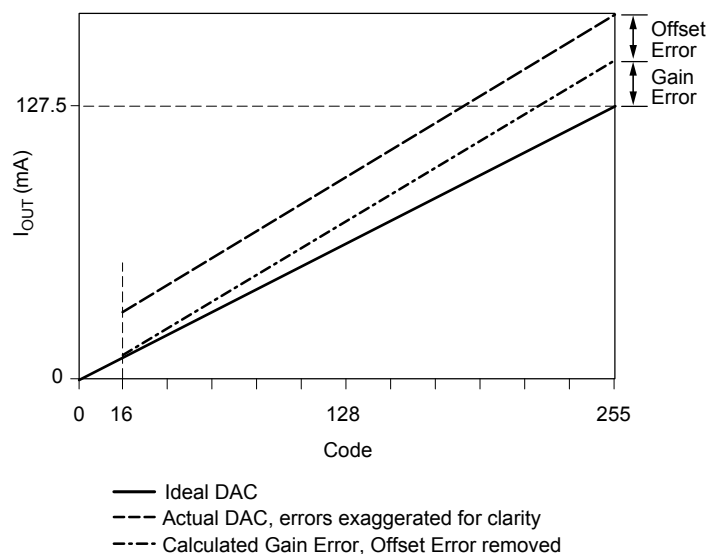
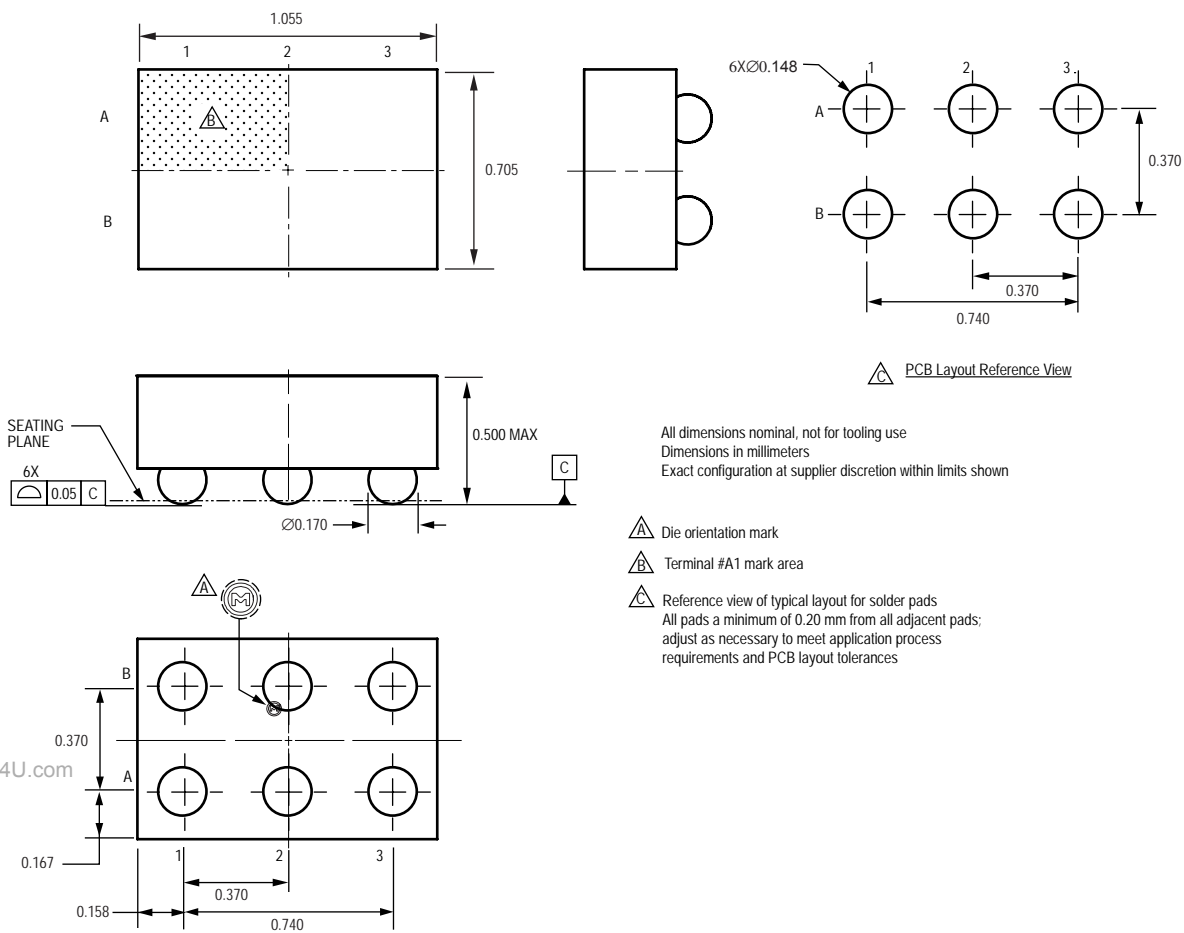

Figure 2. Gain error

# A3904

## Low Voltage Voice Coil Motor Driver

### CG Package, 6-Bump WLCSP



www.DataSheet4U.com

# A3904

# Low Voltage Voice Coil Motor Driver

## CW Package, 8-Bondpad Bare Die

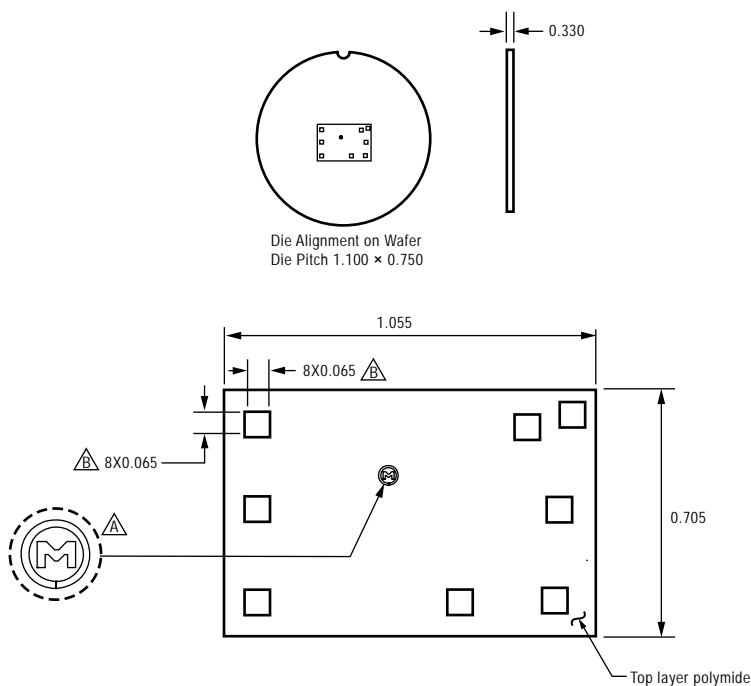

All dimensions nominal: not for tooling use  
 Dimensions in millimeters  
 Exact configuration at supplier discretion within limits shown

- Die orientation mark area
- Bond pad opening in passivation

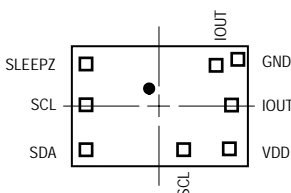

| Bondpad* | X Coordinate (µm) | Y Coordinate (µm) |
|----------|-------------------|-------------------|
| GND      | 444.5             | 269.45            |
| IOUT_1   | 408.7             | 9.7               |
| IOUT_2   | 319.95            | 233.55            |
| SDA      | -421.65           | -242.6            |
| SCL_1    | 136.3             | -243.7            |
| SCL_2    | -421.65           | 9.0               |
| SLEEPZ   | -421.65           | 242.6             |
| VDD      | 396.15            | -238.5            |

\*Redundant bondpads are electrically equivalent and provide alternative locations for bonding.



## A3904

## Low Voltage Voice Coil Motor Driver

## EW Package, 6-Contact DFN

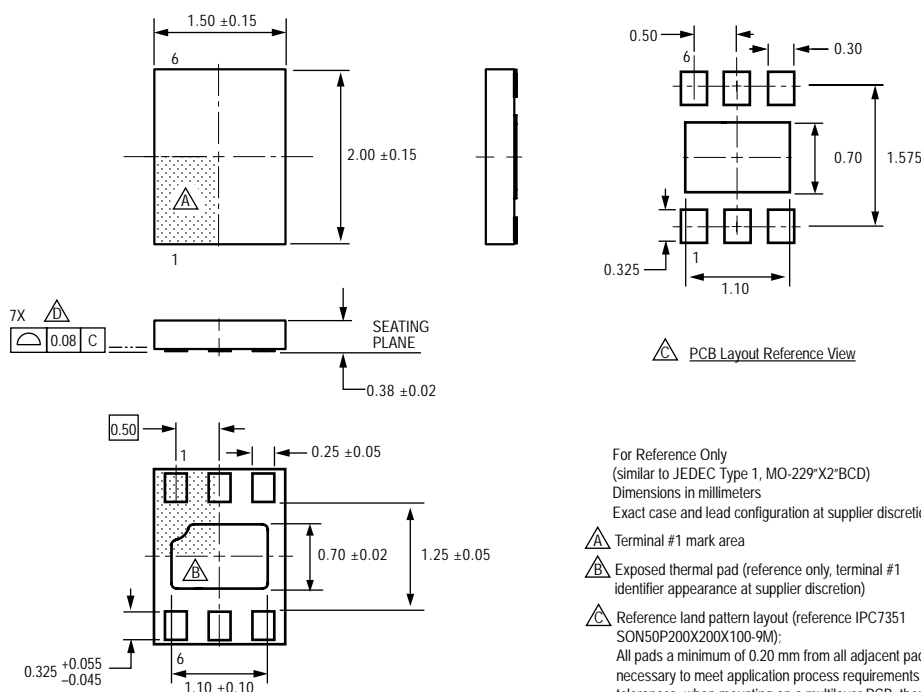

For Reference Only  
(similar to JEDEC Type 1, MO-229-X2'BCD)  
Dimensions in millimeters  
Exact case and lead configuration at supplier discretion within limits shown

- △ Terminal #1 mark area
- △ Exposed thermal pad (reference only, terminal #1 identifier appearance at supplier discretion)
- △ Reference land pattern layout (reference IPC7351 SON50P200X200X100-9M):  
All pads a minimum of 0.20 mm from all adjacent pads; adjust as necessary to meet application process requirements and PCB layout tolerances; when mounting on a multilayer PCB, thermal vias at the exposed thermal pad land can improve thermal dissipation (reference EIA/JEDEC Standard JESD51-5)
- △ Coplanarity includes exposed thermal pad and terminals

www.DataSheet4U.com

Copyright ©2007-2008, Allegro MicroSystems, Inc.

The products described here are manufactured under one or more U.S. patents or U.S. patents pending.

Allegro MicroSystems, Inc. reserves the right to make, from time to time, such departures from the detail specifications as may be required to permit improvements in the performance, reliability, or manufacturability of its products. Before placing an order, the user is cautioned to verify that the information being relied upon is current.

Allegro's products are not to be used in life support devices or systems, if a failure of an Allegro product can reasonably be expected to cause the failure of that life support device or system, or to affect the safety or effectiveness of that device or system.

The information included herein is believed to be accurate and reliable. However, Allegro MicroSystems, Inc. assumes no responsibility for its use; nor for any infringement of patents or other rights of third parties which may result from its use.

For the latest version of this document, visit our website:

[www.allegromicro.com](http://www.allegromicro.com)



Allegro MicroSystems, Inc.  
115 Northeast Cutoff  
Worcester, Massachusetts 01615-0036 U.S.A.  
1.508.853.5000; [www.allegromicro.com](http://www.allegromicro.com)