



## DESCRIPTION

The A4782 is a low-Voltage, single-channel video amplifier with integrated reconstruction filter and input clamps. Specially suited for standard definition video signals, this device is ideal for a wide range of television and set-top box applications.

A4782 offers 6dB Gain rail-to-rail output driver and 5<sup>th</sup> order output reconstruction filter. It has 8MHz -3dB bandwidth and 31.25V/ $\mu$ s slew rate. A4782 provides improved image quality compared with passive LC filters and discrete drivers solution.

A4782 can be DC-coupled or AC-coupled with input video signal, such as the output stage of DAC to eliminate out-of-band noise. The output in A4782 can be configured as DC or AC-coupled output. It operates over an ambient temperature range of -40°C to +85°C.

The A4782 is available in SC70-5 package.

## ORDERING INFORMATION

Package Type	Part Number	
SC70-5	C5	A4782C5R A4782C5VR
Note	V: Halogen free Package R: Tape & Reel	
AiT provides all RoHS products Suffix " V " means Halogen free Package		

## FEATURES

- Operation Temperature Range: -40°C to 85°C
- Single channel 5th Order 8MHz (SD) Filters
- Transparent Input Clamping
- 6dB Output Driver Gain
- Rail-to-Rail Output
- Input Voltage Range Includes Ground
- AC or DC Coupled Inputs / Outputs
- Operates from 3.3V to 5.5V Power Supply
- ESD: pass 8kV HBM test
- Available in SC70-5 Package

## APPLICATION

- Cable and Satellite Set-Top Boxes
- Video Amplifiers
- Communications Devices
- Portable and Handheld Products
- Personal Video Recorders
- Video on Demand, DVD Players

## TYPICAL APPLICATION

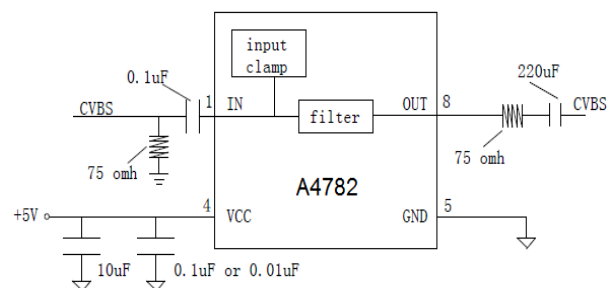



## PIN DESCRIPTION

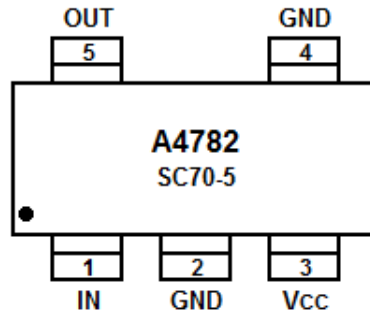

Top View

Pin #	Symbol	I/O	Function
SC70-5			
1	IN	Input	Signal Input
3	V <sub>cc</sub>	Power	The power pad of the chip
2,4	GND	Ground	The ground pad of the chip
5	OUT	Output	Signal Output



## ABSOLUTE MAXIMUM RATINGS

Supply Voltage $V_{CC}$ to GND	-0.3V to 6V
Input Voltage	GND-0.3V~ $V_{CC}$ +0.3V
Storage Temperature Range	-65°C~150°C
Work Temperature Range	-40°C~85°C
$T_A$ , Operating Temperature Range	-40°C~85°C

Stress beyond above listed "Absolute Maximum Ratings" may lead permanent damage to the device. These are stress ratings only and operations of the device at these or any other conditions beyond those indicated in the operational sections of the specifications are not implied. Exposure to absolute maximum rating conditions for extended periods may affect device reliability.



## ELECTRICAL CHARACTERISTICS

At  $V_{CC}=5V$ ,  $R_L=150\Omega$  connected to GND,  $V_{IN}=1V_{pp}$ , and  $C_{IN}=0.1\mu F$ , all outputs AC coupled with  $220\mu F$ , referenced to 400kHz, unless otherwise noted

Parameter	Conditions	Min.	Typ.	Max.	Unit	
<b>DC ELECTRICAL CHARACTERISTICS</b>						
$I_Q$	$V_{IN}=0.5V$	+25°C		7	9.5	mA
		-40 to +85°C			11	
$V_{OLS}$	$V_{IN}=0V$ , No Load	+25°C		395	580	mV
		-40 to +85°C			670	
Input Voltage $V_{CLAMP}$ ( $V_{CLAMP}$ )	$I_{IN}=-3.5mA$	+25°C	-180	-90		mV
		-40 to +85°C	-261			
Clamp Charge Current	$V_{IN}=V_{CLAMP}-100mV$	+25°C	-6	-5.1		mA
		-40 to +85°C	-6.6			
Clamp Discharge Current	$V_{IN}=500mV$	+25°C		0.6	3	$\mu A$
		-40 to +85°C			3.2	
PSRR	DC	+25°C	45	56		dB
		-40 to +85°C	44			
Output Voltage High Swing	$V_{IN}=3V$ , $R_L=150\Omega$ connected to GND	+25°C	4.6	4.8		V
		-40 to +85°C	4.55			
<b>AC ELECTRICAL CHARACTERISTICS</b>						
GAIN ( $A_v$ )	$R_L=150\Omega$ to GND	+25°C	5.6	6	6.4	dB
		-40 to +85°C	5.4		6.5	
BW (-0.1dB)	$R_L=150\Omega$ to GND	+25°C		6		MHz
BW (-3dB)	$R_L=150\Omega$ to GND	+25°C		8		MHz
Filter Response	$f_{IN}=27MHz$	+25°C		48		dB
SLEW RATE	2V outputstep 80% to 20%	+25°C		31.25		V/ $\mu S$
Fall time	2V outputstep 80% to 20%	+25°C		38.4		nS
Rise time	2V outputstep 80% to 20%	+25°C		38.4		nS
D/DT	difference from 400KHz to 6.5MHz	+25°C		31		nS
DG	PAL DC coupled	+25°C		0.6		%
	PAL AC coupled	+25°C		0.88		
DP	PAL DC coupled	+25°C		0.88		%
	PAL AC coupled	+25°C		1.6		



**BLOCK DIAGRAM**

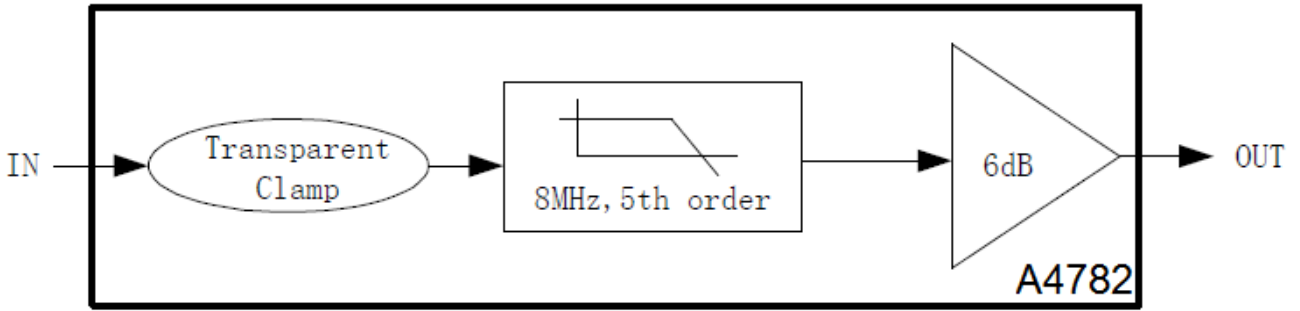



## DETAILED INFORMATION

### Typical Application Diagram

The following schematic in Figure 2 is normally used for AC coupled output and DC coupled input with DAC which has an output voltage range of 0V to 1.4V. AC coupled output offer slightly lower power dissipation and high ESD protection ability. The schematic in Figure 1 is also popular in design.

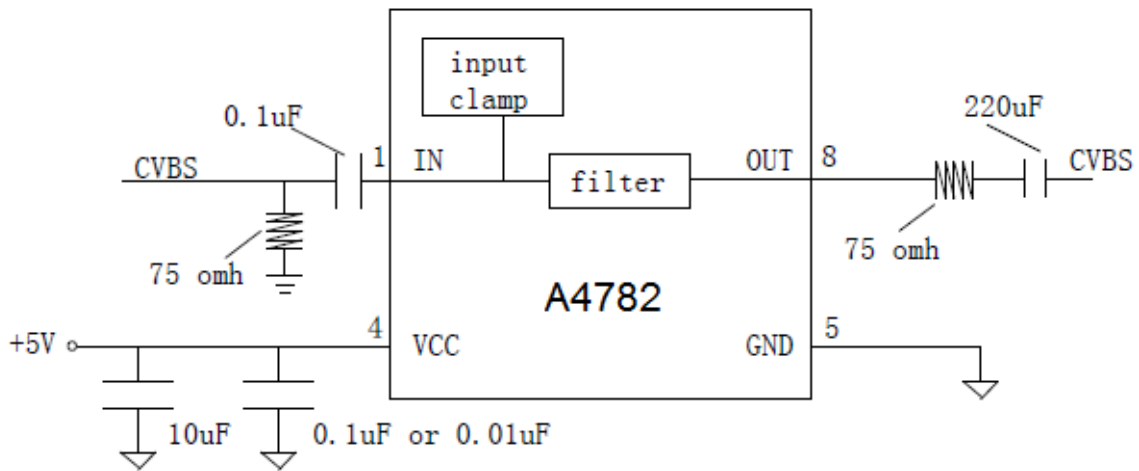

Figure 1. AC Coupling Application Schematic

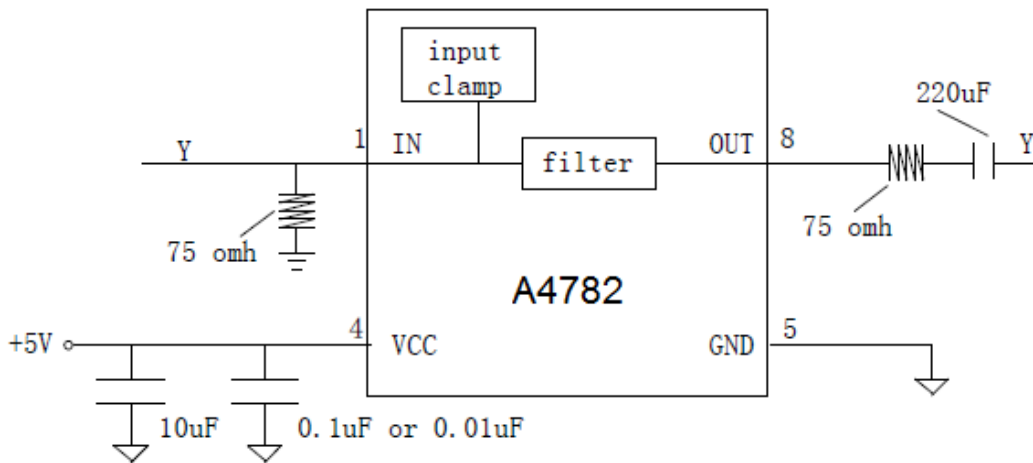

Figure 2. Input DC Coupling Output AC Coupling



## Application Note

### Functional Description

A4782 operates from a single 3.3V to 5V supply. In application, A4782 is a fully integrated solution for filtering and buffering SDTV signals in front of video decoder or behind video encoder. For example, A4782 can replace one passive LC filter and one amplifier driver at CVBS and S-video output side in set-top box and DVD player, this solution can help you save PCB size and production cost, it also improves video signal performance comparing with traditional design using discrete components.

A4782 features a DC-coupled input buffer, 5-pole low-pass filter to eliminate out-of-band noise of video encoder, and a gain of +6dB in the output amplifier to drive 75Ω load. The AC or DC-coupled input buffer eliminates sync crush, droop, and field tilt. The output of A4782 also can be DC-coupled or AC-coupled.

### Input Considerations

Besides AC coupling, the A4782 inputs also can be DC-coupled. In DC coupling application, No input coupling capacitors are needed because the amplitude of input video signal from DAC includes ground and extends up to 1.4V, then A4782 can be directly connected to the output of a single-supply, current-output DAC without any external bias network. Some time, if DAC's output level exceeds the range of 0V to 1.4V, or A4782 is driven by an unknown external source or a SCART switch which has its own clamping circuit; AC coupling is needed in such applications.

### Output Considerations

The A4782 outputs can be DC-coupled or AC-coupled. When 0V is input, the A4782 output voltage is 395mV typically. In DC coupling design, one 75Ω resistor is used to connect A4782's output pin with external load directly, this serial back-termination resistor is used to match the impedance of the transmission line between A4782 and external load to cancel the signal reflection.

The A4782 outputs can sink and source current allowing the device to be AC-coupled with external load, in AC coupling, 220μF at least capacitor will be used in order to eliminate field tilt.

### Power-Supply Bypassing and Layout

Correct power supply bypassing is very important for optimizing video performance in design. One 0.1μF and one 10μF capacitors are always used to Bypass V<sub>CC</sub> pin of A4782, please place these two capacitors as close to the A4782 output pin as possible, a large ground plane is also needed to ensure optimum performance. The input and output termination resistors should be placed as close to the related pin of A4782 as possible to avoid performance degradation. The PCB traces at the output side should have 75Ω characteristic impedance in order to match the 75Ω characteristic impedance cable connecting external load. In design, please keep the board trace at the inputs and outputs of the A4782 as short as possible to minimize the parasitic stray capacitance and noise pickup.



**PACKAGE INFORMATION**

Dimension in SC70-5 (Unit: mm)

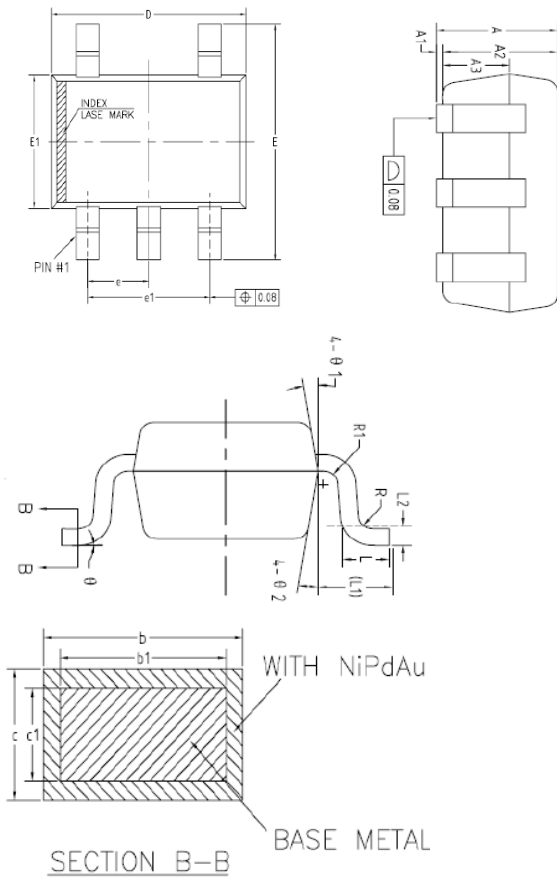

Symbol	Min	Max
A	0.85	1.05
A1	0.00	0.10
A2	0.80	1.00
A3	0.47	0.57
b	0.22	0.29
b1	0.22	0.28
c	0.115	0.15
c1	0.115	0.14
D	2.02	2.12
E	2.20	2.40
E1	1.25	1.35
e	0.65BSC	
e1	1.30BSC	
L	0.28	0.38
L1	0.50REF	
L2	0.15BSC	
R	0.10	-
R1	0.10	0.25
θ	0°	8°
θ1	6°	12°
θ2	6°	12°





## IMPORTANT NOTICE

AiT Semiconductor Inc. (AiT) reserves the right to make changes to any its product, specifications, to discontinue any integrated circuit product or service without notice, and advises its customers to obtain the latest version of relevant information to verify, before placing orders, that the information being relied on is current.

AiT Semiconductor Inc.'s integrated circuit products are not designed, intended, authorized, or warranted to be suitable for use in life support applications, devices or systems or other critical applications. Use of AiT products in such applications is understood to be fully at the risk of the customer. As used herein may involve potential risks of death, personal injury, or severe property, or environmental damage. In order to minimize risks associated with the customer's applications, the customer should provide adequate design and operating safeguards.

AiT Semiconductor Inc. assumes to no liability to customer product design or application support. AiT warrants the performance of its products of the specifications applicable at the time of sale.