

A5M36TG140–TC

Airfast Power Amplifier Module

Rev. 1 — April 2023

Data Sheet: Technical Data

The A5M36TG140–TC is a fully integrated Doherty power amplifier module designed for wireless infrastructure applications that demand high performance in the smallest footprint. Ideal for applications in massive MIMO systems, outdoor small cells and low power remote radio heads. The field-proven LDMOS and GaN-on-SiC power amplifiers are designed for TDD LTE and 5G systems.

3400–3800 MHz

- Typical LTE Performance: $P_{out} = 10$ W Avg., $V_{DC1} = V_{DP1} = 5$ Vdc, $V_{DC2} = V_{DP2} = 48$ Vdc, 1×20 MHz LTE, Input Signal PAR = 8 dB @ 0.01% Probability on CCDF. (1)

Carrier Center Frequency	Gain (dB)	ACPR (dBc)	PAE (%)
3410 MHz	31.0	–27.7	42.9
3600 MHz	31.2	–28.2	46.9
3790 MHz	31.0	–31.7	45.4

1. All data measured with device soldered in NXP reference circuit.

Features

- 2-stage module solution that includes an LDMOS integrated circuit as a driver and a GaN final stage amplifier
- Advanced high performance in-package Doherty
- Thermal path is separated from electrical/solder connection path for enhanced thermal dissipation
- Fully matched (50 ohm input/output, DC blocked)
- Designed for low complexity digital linearization systems
- Reduced memory effects for improved linearized error vector magnitude

A5M36TG140–TC

**3400–3800 MHz, 31 dB, 10 W Avg.
AIRFAST POWER AMPLIFIER
MODULE**



14 mm × 10 mm Module

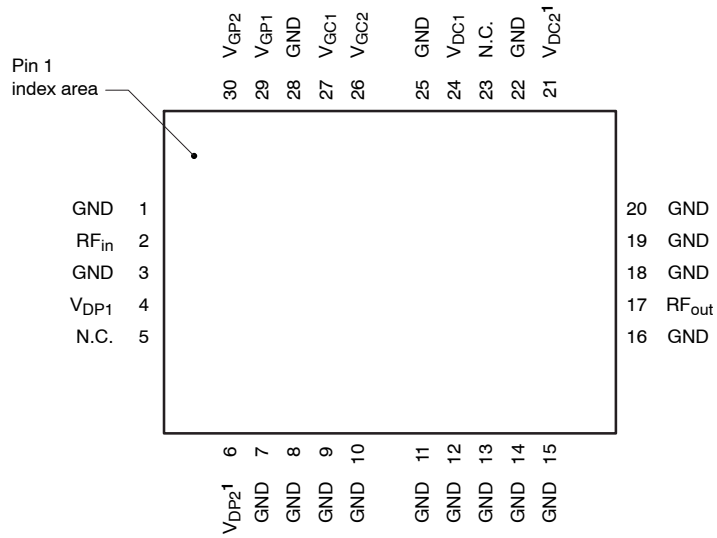

(Thermal Path View)

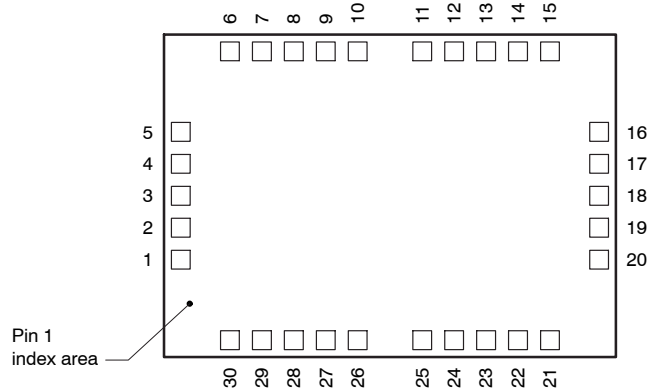

(Solderable Path View)

aaa-042115

Figure 1. Pin Connections

1. V_{DP2} and V_{DC2} are DC coupled internal to the package and must be powered by a single DC power supply.

Table 1. Functional Pin Description

Pin Number	Pin Function	Pin Description
1, 3, 7, 8, 9, 10, 11, 12, 13, 14, 15, 16, 18, 19, 20, 22, 25, 28	GND	Ground
2	RF _{in}	RF Input
4	V _{DP1}	Peaking Drain Supply, Stage 1
5, 23	N.C.	No Connection
6	V _{DP2}	Peaking Drain Supply, Stage 2
17	RF _{out}	RF Output
21	V _{DC2}	Carrier Drain Supply, Stage 2
24	V _{DC1}	Carrier Drain Supply, Stage 1
26	V _{GC2}	Carrier Gate Supply, Stage 2
27	V _{GC1}	Carrier Gate Supply, Stage 1
29	V _{GP1}	Peaking Gate Supply, Stage 1
30	V _{GP2}	Peaking Gate Supply, Stage 2

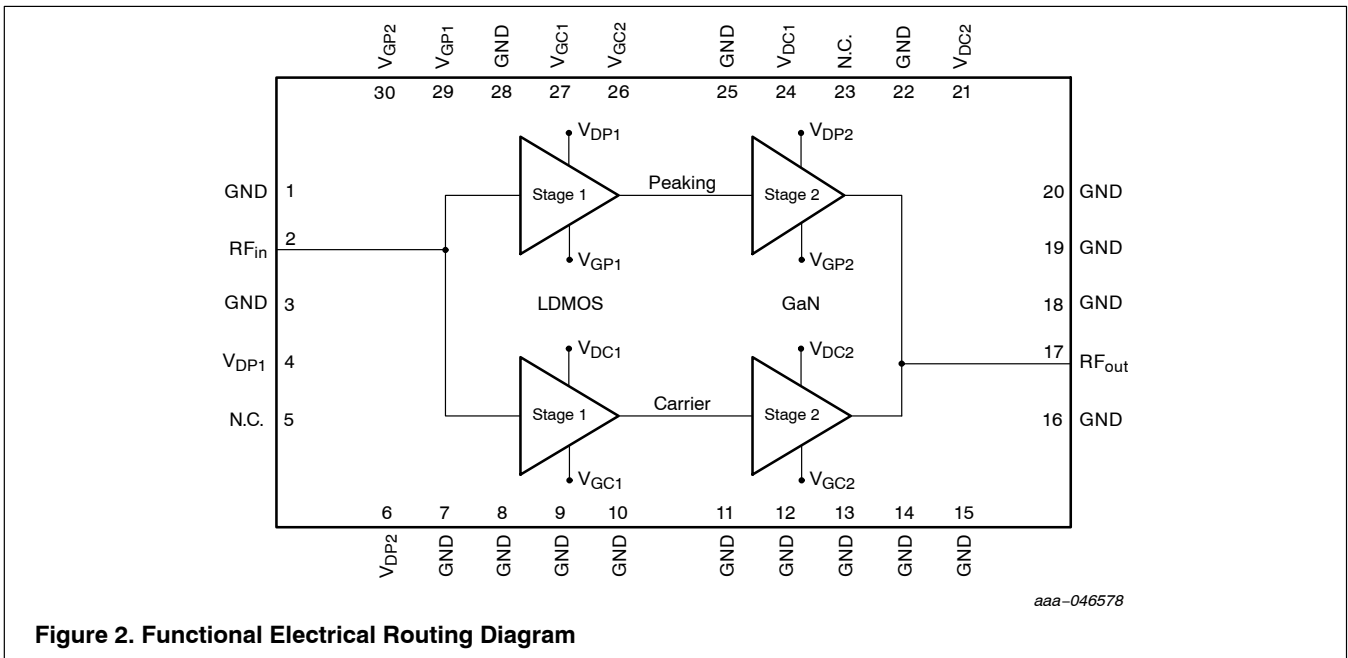

Figure 2. Functional Electrical Routing Diagram

Table 2. Maximum Ratings

Rating	Symbol	Value	Unit
Gate-Bias Voltage Range	V_{G1} V_{G2}	-0.5 to +10 -6, 0	Vdc
Operating Voltage Range	V_{DD1} V_{DD2}	4.75 to 5.25 +38 to +55	Vdc
Maximum Forward Gate Current, I_G (A+B), @ $T_C = 25^\circ\text{C}$	I_{GMAX}	11.3	mA
Storage Temperature Range	T_{stg}	-65 to +150	$^\circ\text{C}$
Case Operating Temperature	T_C	125	$^\circ\text{C}$
Maximum Channel Temperature	T_{CH}	225	$^\circ\text{C}$
Peak Input Power (3600 MHz, Pulsed CW, 10 μsec (on), 10% Duty Cycle, $V_{DC1} = V_{DP1} = 5 \text{ Vdc}$, $V_{DC2} = V_{DP2} = 48 \text{ Vdc}$)	P_{in}	28	dBm

Table 3. Lifetime

Characteristic	Symbol	Value	Unit
Mean Time to Failure Case Temperature 125°C , 75% Duty Cycle, 10 W Avg., $V_{DC1} = V_{DP1} = 5 \text{ Vdc}$, $V_{DC2} = V_{DP2} = 48 \text{ Vdc}$	MTTF	> 10	Years

Table 4. Thermal Characteristics

Characteristic	Symbol	Value	Unit
Thermal Resistance by Infrared Measurement, Active Die Surface-to-Case Case Temperature 125°C , $P_D = 12.6 \text{ W}$	$R_{\theta JC}$ (IR)	4.3 (1)	$^\circ\text{C/W}$
Thermal Resistance by Finite Element Analysis, Channel-to-Case Case Temperature 125°C , $P_D = 12.6 \text{ W}$	$R_{\theta CHC}$ (FEA)	7.9 (2)	$^\circ\text{C/W}$

Table 5. ESD Protection Characteristics

Test Methodology	Class
Human Body Model (per JS-001-2017)	2
Charge Device Model (per JS-002-2014)	C3

Table 6. Moisture Sensitivity Level

Test Methodology	Rating	Package Peak Temperature	Unit
Per JESD22-A113, IPC/JEDEC J-STD-020	3/R6	250	$^\circ\text{C}$

1. Refer to AN1955, *Thermal Measurement Methodology of RF Power Amplifiers*. Go to <http://www.nxp.com/RF> and search for AN1955. High conductivity thermal interface used.
2. $R_{\theta CHC}$ (FEA) must be used for purposes related to reliability and limitations on maximum channel temperature. MTTF may be estimated by the expression $\text{MTTF (hours)} = 10^{[A + B/(T + 273)]}$, where T is the channel temperature in degrees Celsius, $A = -11.6$ and $B = 9129$.

Table 7. Electrical Characteristics ($T_A = 25^\circ\text{C}$ unless otherwise noted)

Characteristic	Symbol	Min	Typ	Max	Unit
Carrier + Peaking Stage 2, GaN — Off Characteristics					
Off-State Drain Leakage ⁽¹⁾ ($V_{DS} = 150\text{ Vdc}$, $V_{GS} = -8\text{ Vdc}$)	$I_{D(BR)}$	—	—	5.0	mAdc
Off-State Gate Leakage ($V_{DS} = 48\text{ Vdc}$, $V_{GS} = -7\text{ Vdc}$)	I_{GLK}	-4.0	—	—	mAdc
Characteristic	Symbol	Typ	Range	Unit	
Carrier Stage 1, LDMOS — On Characteristics					
Gate Threshold Voltage ($V_{DS} = 5\text{ Vdc}$, $I_{DC1} = 120\ \mu\text{Adc}$)	$V_{GS(th)}$	1.3	± 0.4	Vdc	
Gate Quiescent Voltage ($V_{DS} = 5\text{ Vdc}$, $I_{DQC1} = 145\text{ mAdc}$, Measured in Functional Test)	$V_{GS(Q)}$	2.0	± 0.4	Vdc	
Carrier Stage 2, GaN — On Characteristics					
Gate Threshold Voltage ⁽¹⁾ ($V_{DS} = 10\text{ Vdc}$, $I_D = 11.3\text{ mAdc}$)	$V_{GS(th)}$	-3.0	± 1.0	Vdc	
Gate Quiescent Voltage ($V_{DS} = 48\text{ Vdc}$, $I_{DQC2} = 25\text{ mAdc}$, Measured in Functional Test)	$V_{GS(Q)}$	-2.7	± 1.0	Vdc	
Peaking Stage 1, LDMOS — On Characteristics					
Gate Threshold Voltage ($V_{DS} = 5\text{ Vdc}$, $I_{DP1} = 120\ \mu\text{Adc}$)	$V_{GS(th)}$	1.4	± 0.4	Vdc	
Gate Quiescent Voltage ($V_{DS} = 5\text{ Vdc}$, $I_{DQP1} = 37\text{ mAdc}$, Measured in Functional Test)	$V_{GS(Q)}$	1.8	± 0.4	Vdc	
Peaking Stage 2, GaN — On Characteristics					
Gate Threshold Voltage ⁽¹⁾ ($V_{DS} = 10\text{ Vdc}$, $I_D = 11.3\text{ mAdc}$)	$V_{GS(th)}$	-3.0	± 1.0	Vdc	
Gate Quiescent Voltage ($V_{DS} = 48\text{ Vdc}$, $I_{DQP2} = 0\text{ mAdc}$, Measured in Functional Test)	$V_{GS(Q)}$	-2.9	± 1.0	Vdc	

1. Carrier side and Peaking side are tied together for these measurements.

(continued)

Table 7. Electrical Characteristics ($T_A = 25^\circ\text{C}$ unless otherwise noted) (continued)

Characteristic	Symbol	Min	Typ	Max	Unit
Functional Tests — 3400 MHz ⁽¹⁾ (In NXP Doherty Production ATE ⁽²⁾ Test Fixture, 50 ohm system) $V_{DD1} = 5\text{ Vdc}$, $V_{DD2} = 48\text{ Vdc}$, $I_{DQC1} = 145\text{ mA}$, $I_{DQC2} = 25\text{ mA}$, $I_{DQP1} = 37\text{ mA}$, $V_{GP2} = (V_{BIAS} - 0.31)$ ⁽³⁾ Vdc, $P_{out} = 10\text{ W Avg.}$, 1-tone CW, $f = 3400\text{ MHz}$.					
Gain	G	28.2	31.3	—	dB
Drain Efficiency	η_D	36.0	42.0	—	%
P_{out} @ 3 dB Compression Point	P3dB	47.4	48.7	—	dBm
Functional Tests — 3800 MHz ⁽¹⁾ (In NXP Doherty Production ATE ⁽²⁾ Test Fixture, 50 ohm system) $V_{DD1} = 5\text{ Vdc}$, $V_{DD2} = 48\text{ Vdc}$, $I_{DQC1} = 145\text{ mA}$, $I_{DQC2} = 25\text{ mA}$, $I_{DQP1} = 37\text{ mA}$, $V_{GP2} = (V_{BIAS} - 0.31)$ ⁽³⁾ Vdc, $P_{out} = 10\text{ W Avg.}$, 1-tone CW, $f = 3800\text{ MHz}$.					
Gain	G	28.1	31.9	—	dB
Drain Efficiency	η_D	40.0	48.6	—	%
P_{out} @ 3 dB Compression Point	P3dB	47.5	48.7	—	dBm
Wideband Ruggedness ⁽⁴⁾ (In NXP Doherty Power Amplifier Module Reference Circuit, 50 ohm system) $I_{DQC1} = 145\text{ mA}$, $I_{DQC2} = 25\text{ mA}$, $I_{DQP1} = 35\text{ mA}$, $V_{GP2} = (V_{BIAS} - 0.31)$ ⁽⁵⁾ Vdc, $f = 3600\text{ MHz}$, Additive White Gaussian Noise (AWGN) with 10 dB PAR					
ISBW of 400 MHz at 55 Vdc, 3 dB Input Overdrive from 10 W Avg. Modulated Output Power	No Device Degradation				
Typical Performance ⁽⁴⁾ (In NXP Doherty Power Amplifier Module Reference Circuit, 50 ohm system) $V_{DD1} = 5\text{ Vdc}$, $V_{DD2} = 48\text{ Vdc}$, $I_{DQC1} = 145\text{ mA}$, $I_{DQC2} = 25\text{ mA}$, $I_{DQP1} = 35\text{ mA}$, $V_{GP2} = (V_{BIAS} - 0.31)$ ⁽⁵⁾ Vdc, 3600 MHz					
VBW Resonance Point, 2-tone, 1 MHz Tone Spacing (IMD Third Order Intermodulation Inflection Point)	VBW _{res}	—	330	—	MHz
1-carrier 20 MHz LTE, 8 dB Input Signal PAR					
Gain	G	—	31.2	—	dB
Power Added Efficiency	PAE	—	46.9	—	%
Adjacent Channel Power Ratio	ACPR	—	-28.2	—	dBc
Adjacent Channel Power Ratio	ALT1	—	-42.4	—	dBc
Adjacent Channel Power Ratio	ALT2	—	-49.0	—	dBc
Gain Flatness ⁽⁶⁾	G _F	—	0.2	—	dB
Pulsed CW, 10% Duty Cycle					
P_{out} @ 3 dB Compression Point	P3dB	—	49.3	—	dBm
AM/PM @ P3dB	Φ	—	-27	—	°
Gain Variation @ Avg. Power over Temperature (-40°C to +125°C)	ΔG	—	0.051	—	dB/°C
P3dB Variation over Temperature (-40°C to +125°C)	$\Delta P3dB$	—	0.006	—	dB/°C

Table 8. Ordering Information

Device	Tape and Reel Information	Package
A5M36TG140-TCT1	T1 Suffix = 1,000 Units, 24 mm Tape Width, 13-inch Reel	14 mm × 10 mm Module

- Part input and output matched to 50 ohms.
- ATE is a socketed test environment.
- Increase V_{GP2} (peaking side) until $I_{DQP2} = 38\text{ mA}$ current is attained, and then subtract 0.31 V for final V_{GP2} bias voltage.
- All data measured in fixture with device soldered in NXP reference circuit.
- Increase V_{GP2} (peaking side) until $I_{DQP2} = 40\text{ mA}$ current is attained, and then subtract 0.31 V for final V_{GP2} bias voltage.
- Gain flatness = $\text{Max}(G(f_{Low} \text{ to } f_{High})) - \text{Min}(G(f_{Low} \text{ to } f_{High}))$

Correct Biasing Sequence

Turn ON:

Bias ON the GaN final stage first

1. Set gate voltage V_{GC2} and V_{GP2} to -5 V.
2. Set drain voltage V_{DC2} and V_{DP2} to nominal supply voltage ($+48$ V).
3. Increase V_{GP2} (peaking side) until $I_{DQP2} = 40$ mA current is attained, and then subtract 0.31 V for final V_{GP2} bias voltage.
4. Increase V_{GC2} (carrier side) until I_{DQC2} current is attained.

Bias ON the LDMOS driver stage second

5. Set drain voltage V_{DC1} and V_{DP1} to nominal supply voltage ($+5$ V).
6. Increase V_{GC1} (carrier side) until I_{DQC1} current is attained.
7. Increase V_{GP1} (peaking side) until I_{DQP1} current is attained.
8. Apply RF input power to desired level.

Turn OFF:

Bias OFF the GaN final stage first

1. Disable RF input power.
2. Adjust gate voltage V_{GC2} and V_{GP2} to -5 V.
3. Adjust drain voltage V_{DC2} and V_{DP2} to 0 V. Allow adequate time for drain voltage to reduce to 0 V from external drain capacitors.
4. Disable V_{GC2} and V_{GP2} .

Bias OFF the LDMOS driver stage second

5. Adjust gate voltage V_{GC1} and V_{GP1} to 0 V.
6. Adjust drain voltage V_{DC1} and V_{DP1} to 0 V.

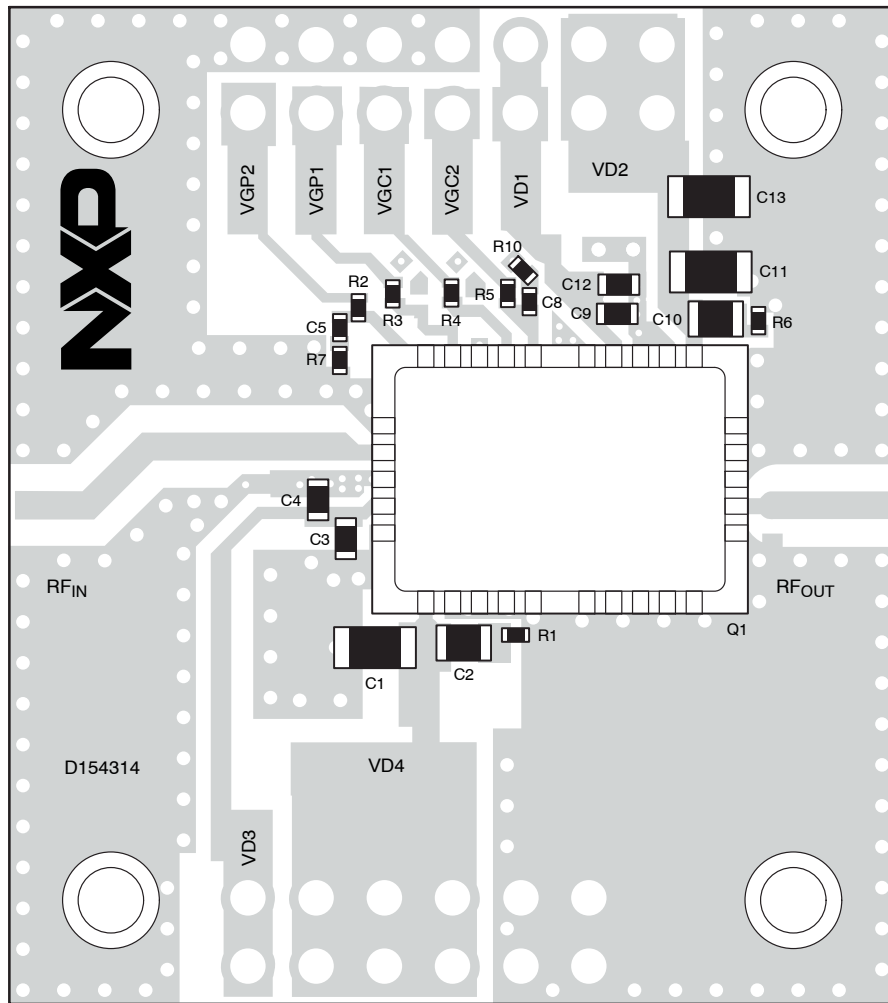

aaa-045919

Board Label	Pin Description	Pin Function
VD1	Carrier Drain Supply, Stage 1	V_{DC1}
VD2	Carrier Drain Supply, Stage 2	V_{DC2}
VD3	Peaking Drain Supply, Stage 1	V_{DP1}
VD4	Peaking Drain Supply, Stage 2	V_{DP2}

Figure 3. A5M36TG140–TC Reference Circuit Component Layout

Table 9. A5M36TG140–TC Reference Circuit Component Designations and Values

Part	Description	Part Number	Manufacturer
C1, C11, C13	4.7 μ F Chip Capacitor	GRM31CC72A475KE11L	Murata
C2, C10	1 μ F Chip Capacitor	GRM21BC72A105KE01L	Murata
C3, C9	1 μ F Chip Capacitor	GRT188R61H105KE13D	Murata
C4, C12	10 μ F Chip Capacitor	GRM188R61E106KA73D	Murata
C5	0.1 μ F Chip Capacitor	GRM155R61H104KE19D	Murata
C8	10 nF Chip Capacitor	GRM155R71E103KA01D	Murata
Q1	Power Amplifier Module	A5M36TG140–TC	NXP
R1, R6	2 Ω , 1/10 W Chip Resistor	ERJ–2GEJ2R0X	Panasonic
R2, R3, R5	1 Ω , 1/10 W Chip Resistor	ERJ–2GEJ1R0X	Panasonic
R4, R10	10 Ω , 1/10 W Chip Resistor	ERJ–2GEJ100X	Panasonic
R7	0 Ω , 1/20 W Chip Resistor	ERJ–1GN0R00C	Panasonic
PCB	Megtron R–5575, 0.020", $\epsilon_r = 3.67$	D154314	MTL

Note: Component numbers C6, C7, R8 and R9 are intentionally omitted.

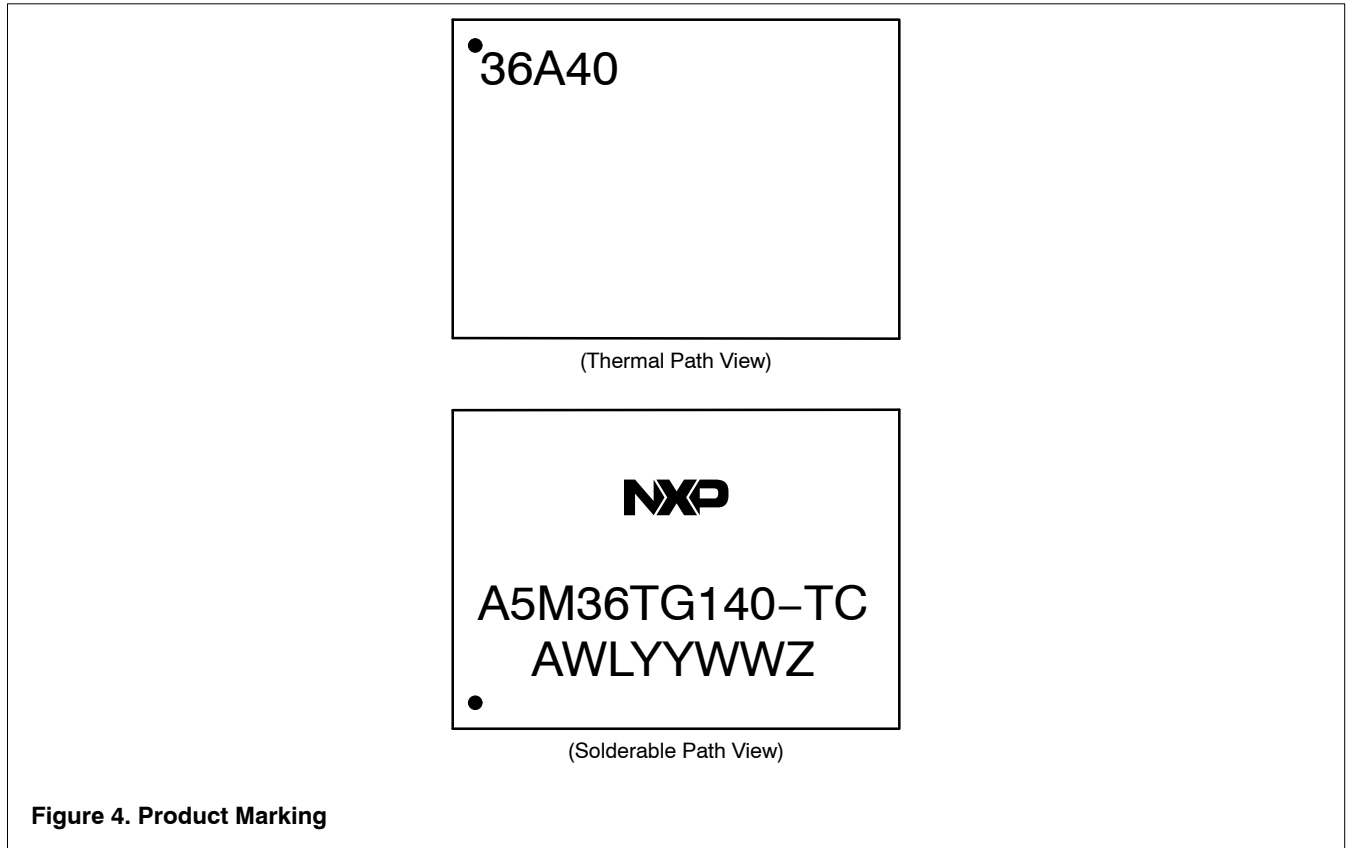

Figure 4. Product Marking

Table 10. Product Marking Trace Code

Identifier	Description
A	Assembly location
WL	Wafer lot indicator
YYWW	Date code
Z	Assembly lot

Package Information

H-PLGA-30 I/O
14 X 10 X 1.97 PKG, 1 PITCH

SOT2131-2

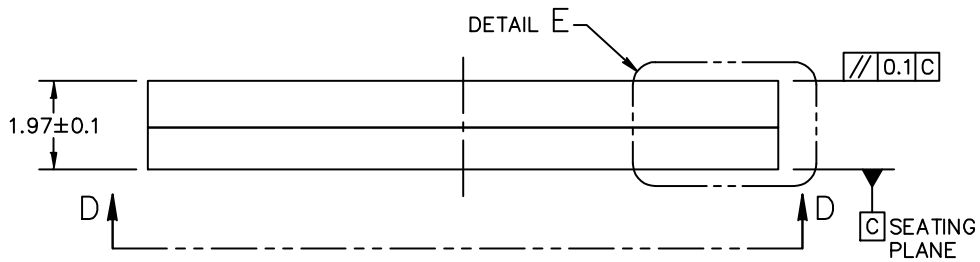
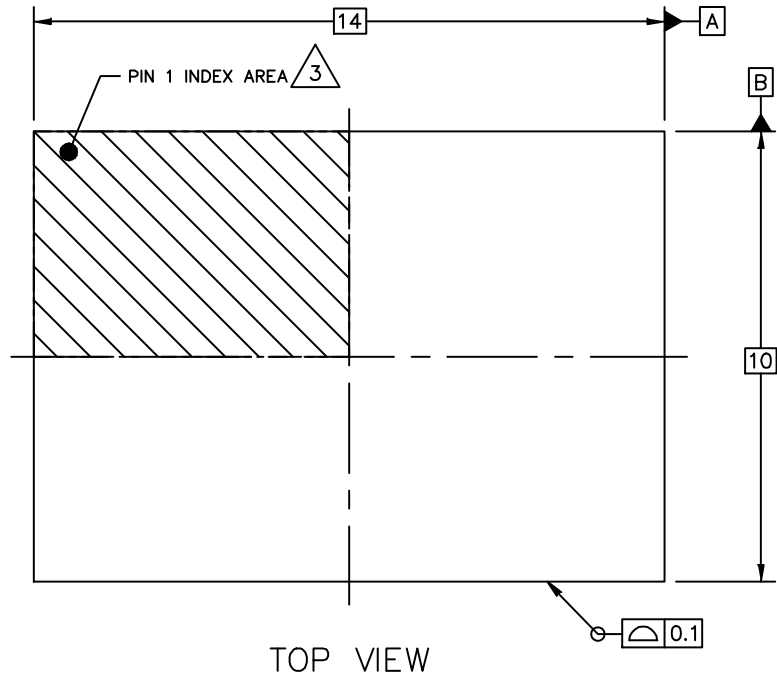

© NXP B.V. ALL RIGHTS RESERVED

DATE: 28 SEP 2022

MECHANICAL OUTLINE PRINT VERSION NOT TO SCALE	STANDARD: NON-JEDEC	DRAWING NUMBER: 98ASA01864D	REVISION: A	PAGE: 1 OF 6
--------------------------------------------------	------------------------	--------------------------------	----------------	-----------------

H-PLGA-30 I/O
14 X 10 X 1.97 PKG, 1 PITCH

SOT2131-2

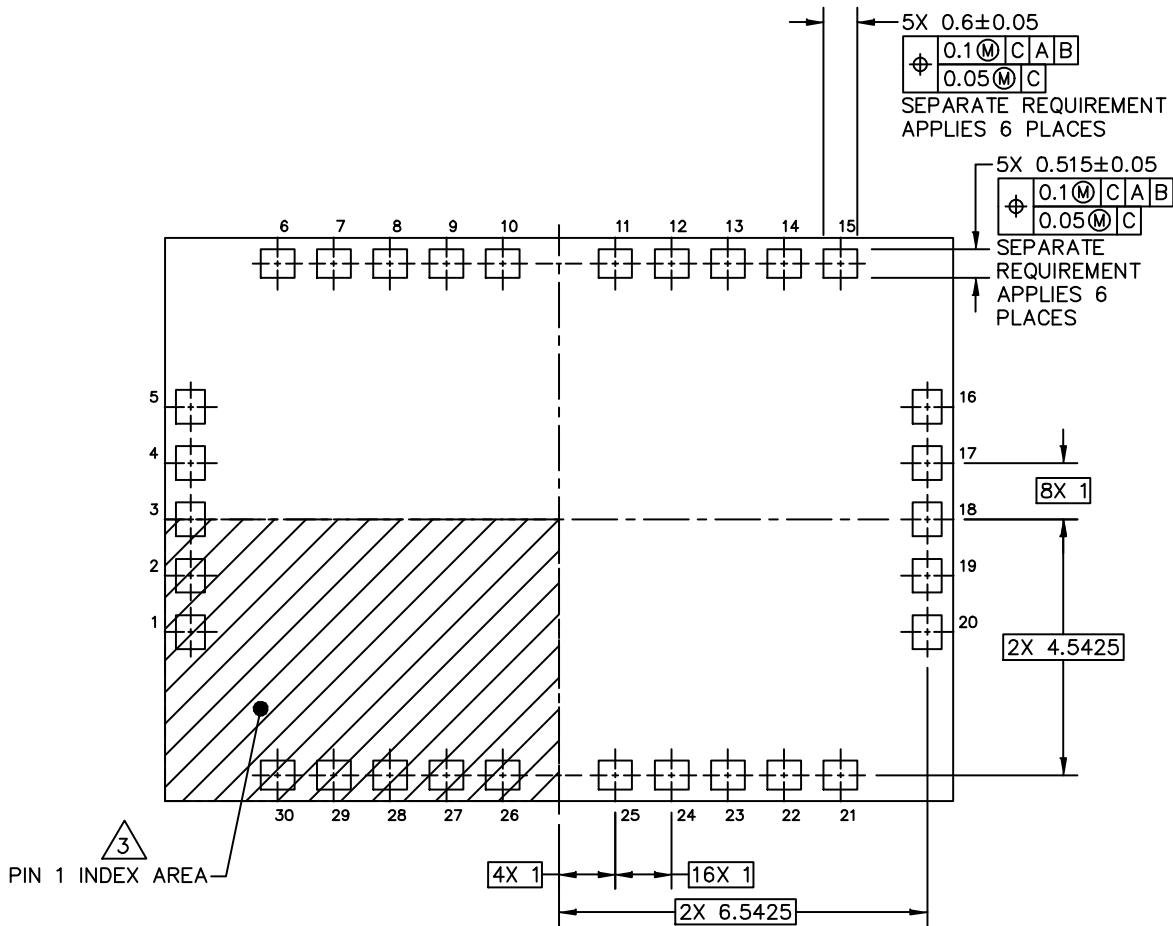

VIEW D-D
(BOTTOM VIEW)

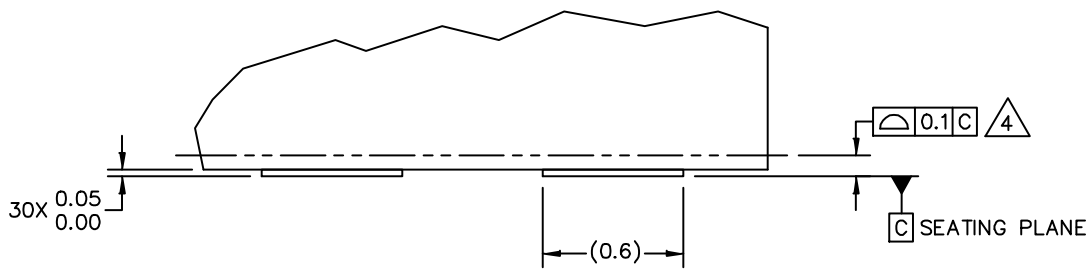

DETAIL E

© NXP B.V. ALL RIGHTS RESERVED

DATE: 28 SEP 2022

MECHANICAL OUTLINE PRINT VERSION NOT TO SCALE	STANDARD: NON-JEDEC	DRAWING NUMBER: 98ASA01864D	REVISION: A	PAGE: 2
--------------------------------------------------	------------------------	--------------------------------	----------------	------------

H-PLGA-30 I/O
14 X 10 X 1.97 PKG, 1 PITCH

SOT2131-2

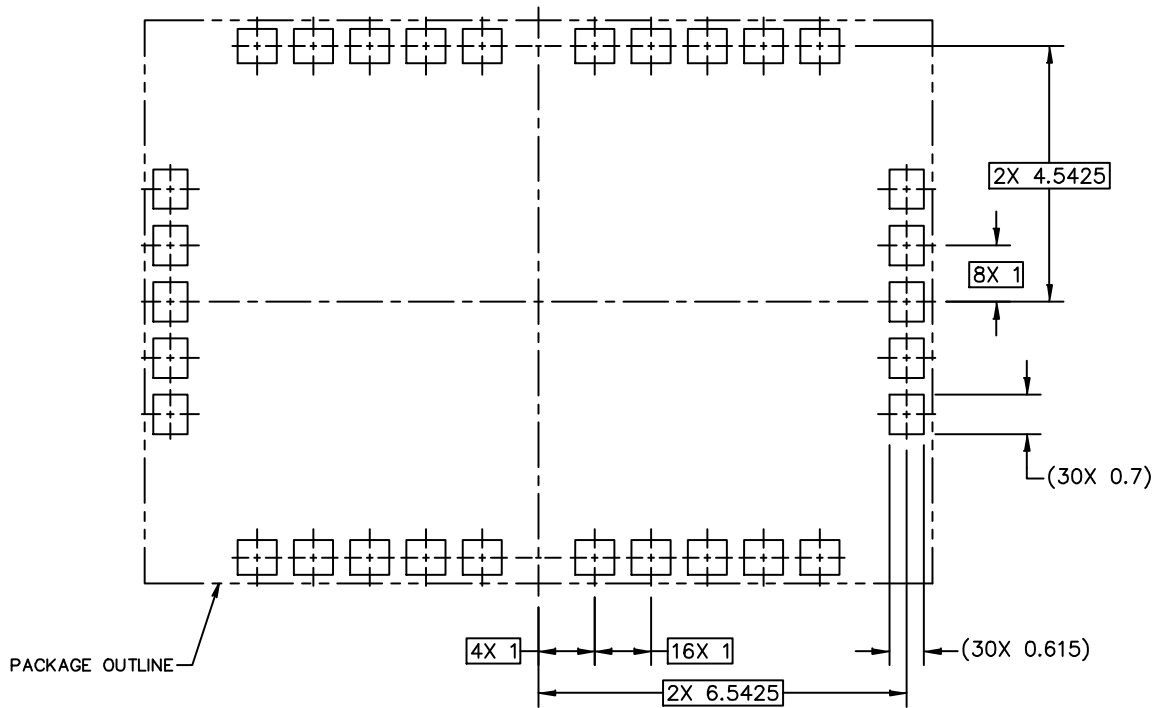

PCB DESIGN GUIDELINES – SOLDER MASK OPENING PATTERN

THIS SHEET SERVES ONLY AS A GUIDELINE TO HELP DEVELOP A USER SPECIFIC SOLUTION. DEVELOPMENT EFFORT WILL STILL BE REQUIRED BY END USERS TO OPTIMIZE PCB MOUNTING PROCESSES AND BOARD DESIGN IN ORDER TO MEET INDIVIDUAL/SPECIFIC REQUIREMENTS.

© NXP B.V. ALL RIGHTS RESERVED

DATE: 28 SEP 2022

MECHANICAL OUTLINE PRINT VERSION NOT TO SCALE	STANDARD: NON-JEDEC	DRAWING NUMBER: 98ASA01864D	REVISION: A	PAGE: 3
--------------------------------------------------	------------------------	--------------------------------	----------------	------------

H-PLGA-30 I/O
14 X 10 X 1.97 PKG, 1 PITCH

SOT2131-2

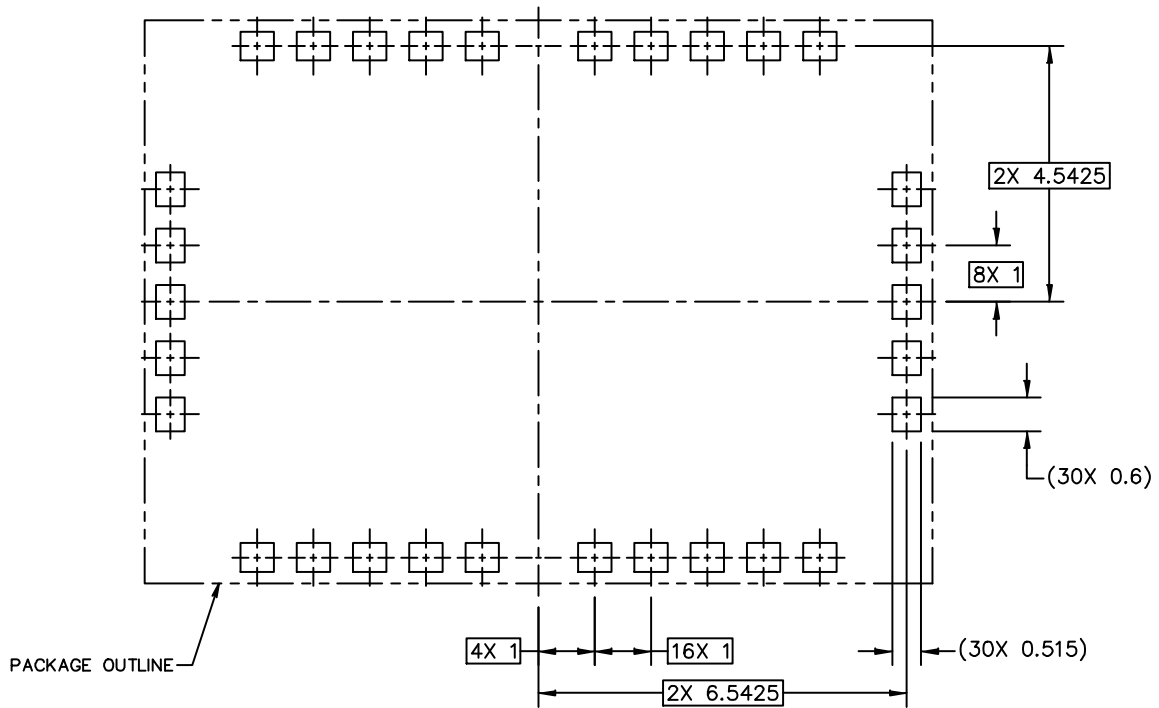

PCB DESIGN GUIDELINES – I/O PADS AND SOLDERABLE AREAS

THIS SHEET SERVES ONLY AS A GUIDELINE TO HELP DEVELOP A USER SPECIFIC SOLUTION. DEVELOPMENT EFFORT WILL STILL BE REQUIRED BY END USERS TO OPTIMIZE PCB MOUNTING PROCESSES AND BOARD DESIGN IN ORDER TO MEET INDIVIDUAL/SPECIFIC REQUIREMENTS.

© NXP B.V. ALL RIGHTS RESERVED

DATE: 28 SEP 2022

MECHANICAL OUTLINE PRINT VERSION NOT TO SCALE	STANDARD: NON-JEDEC	DRAWING NUMBER: 98ASA01864D	REVISION: A	PAGE: 4
--------------------------------------------------	------------------------	--------------------------------	----------------	------------

H-PLGA-30 I/O
14 X 10 X 1.97 PKG, 1 PITCH

SOT2131-2

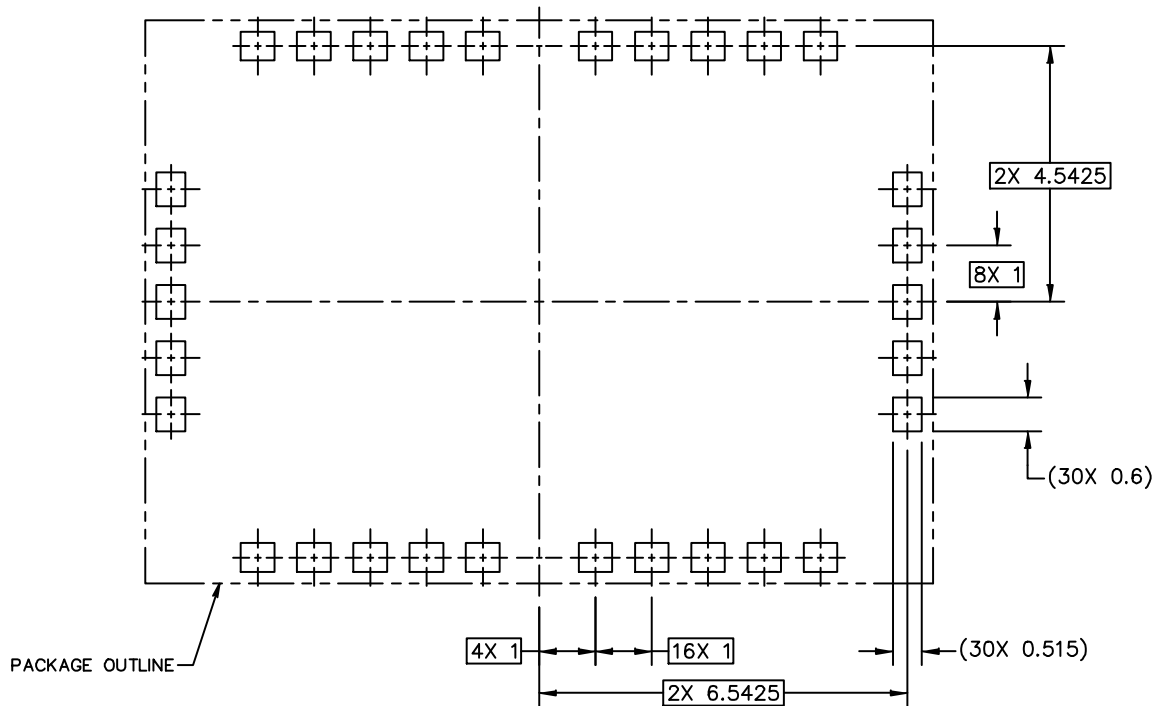

RECOMMENDED STENCIL THICKNESS 0.125 OR 0.150

PCB DESIGN GUIDELINES – SOLDER PASTE STENCIL

THIS SHEET SERVES ONLY AS A GUIDELINE TO HELP DEVELOP A USER SPECIFIC SOLUTION. DEVELOPMENT EFFORT WILL STILL BE REQUIRED BY END USERS TO OPTIMIZE PCB MOUNTING PROCESSES AND BOARD DESIGN IN ORDER TO MEET INDIVIDUAL/SPECIFIC REQUIREMENTS.

© NXP B.V. ALL RIGHTS RESERVED

DATE: 28 SEP 2022

MECHANICAL OUTLINE PRINT VERSION NOT TO SCALE	STANDARD: NON-JEDEC	DRAWING NUMBER: 98ASA01864D	REVISION: A	PAGE: 5
--------------------------------------------------	------------------------	--------------------------------	----------------	------------

H-PLGA-30 I/O
14 X 10 X 1.97 PKG, 1 PITCH

SOT2131-2

NOTES:

1. ALL DIMENSIONS IN MILLIMETERS.
2. DIMENSIONING AND TOLERANCING PER ASME Y14.5M-1994.

3. PIN 1 FEATURE SHAPE, SIZE AND LOCATION MAY VARY.

4. COPLANARITY APPLIES TO ALL LEADS.

© NXP B.V. ALL RIGHTS RESERVED

DATE: 28 SEP 2022

MECHANICAL OUTLINE PRINT VERSION NOT TO SCALE	STANDARD: NON-JEDEC	DRAWING NUMBER: 98ASA01864D	REVISION: A	PAGE: 6
--------------------------------------------------	------------------------	--------------------------------	----------------	------------

Product Documentation and Tools

Refer to the following resources to aid your design process.

Application Notes

- AN1955: Thermal Measurement Methodology of RF Power Amplifiers

Development Tools

- Printed Circuit Boards

Revision History

The following table summarizes revisions to this document.

Revision	Date	Description
0	Oct. 2022	<ul style="list-style-type: none">• Initial release of data sheet
1	Apr. 2023	<ul style="list-style-type: none">• Table 7, Functional Tests at 3400 MHz and 3800 MHz: Min efficiency value updated to match production test value, p. 6• Table 10, Product Marking Trace Code: added, p. 9

How to Reach Us

Home Page:
nxp.com

Web Support:
nxp.com/support

Information in this document is provided solely to enable system and software implementers to use NXP products. There are no express or implied copyright licenses granted hereunder to design or fabricate any integrated circuits based on the information in this document. NXP reserves the right to make changes without further notice to any products herein.

NXP makes no warranty, representation, or guarantee regarding the suitability of its products for any particular purpose, nor does NXP assume any liability arising out of the application or use of any product or circuit, and specifically disclaims any and all liability, including without limitation consequential or incidental damages. "Typical" parameters that may be provided in NXP data sheets and/or specifications can and do vary in different applications, and actual performance may vary over time. All operating parameters, including "typicals," must be validated for each customer application by customer's technical experts. NXP does not convey any license under its patent rights nor the rights of others. NXP sells products pursuant to standard terms and conditions of sale, which can be found at the following address: nxp.com/SalesTermsandConditions.

NXP, the NXP logo and Airfast are trademarks of NXP B.V. All other product or service names are the property of their respective owners.

© NXP B.V. 2022–2023

All rights reserved.

For more information, please visit: <http://www.nxp.com>

For sales office addresses, please send an email to: salesaddresses@nxp.com