



DESCRIPTION

The A6155 is a dual output, low noise; low-dropout regulator delivers at least 150mA of continuous output current. The output voltage for each regulator is set independently by trimming. Voltages are selectable in 100mV steps within a range of 1.2V to 5.0V. Typical output noise is 27uV_{RMS}, and PSRR is 65dB at 1KHz.

The A6155 includes two independent logic-controlled shutdown inputs and allows the output of each regulator to be turned off independently.

The A6155 includes high accuracy voltage reference, error amplifier, and current limit circuit and output driver module.

The A6155 has excellent load and line transient response and good temperature characteristics, which can assure the stability of chip and power system and A6155 uses trimming technique to guarantee output voltage accuracy within ±2%.

The A6155 is available in SOT-26 package.

ORDERING INFORMATION

Package Type	Part Number	
SOT-26	E6	A6155E6R-XZ
		A6155E6VR-XZ
Note	X: Output Portfolio See output voltage portfolio Z: Pin Type, C or D V: Green Package R: Tape & Reel	
AiT provides all Pb free products Suffix " V " means Green Package		

FEATURES

- Low Output Noise (27uV_{RMS})
- Standby Mode: 0.1uA
- 150mA output current for each channel
- 25uA Operating Supply Current per channel
- High Ripple Rejection: 65dB@1KHz(Typ.)
- Low 200mV dropout at 100mA load
- Excellent Line Regulation: 0.05%/V
- Built-in chip Enable Circuit
- Independent Shutdown Controls
- Output Voltage Range: 1.2V~5.0V
- Output Current Limit
- Highly Accurate: ±2% (±1% customized)
- Available in SOT-26 Package

APPLICATION

- Power Source for Cellular Phones and various kind of PCs
- Battery Powered Equipment
- Power Management of MP3, PDA, DSC, Mouse, PS2 Games
- Reference Voltage Source
- Regulation after Switching Power
- Notebook and Handheld equipment
- Wireless LAN, Bluetooth, GPS Receivers
- Cordless Phones
- Radio Communication Equipment

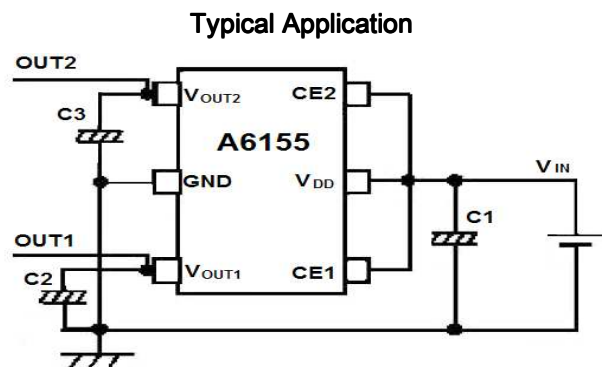



PIN DESCRIPTION

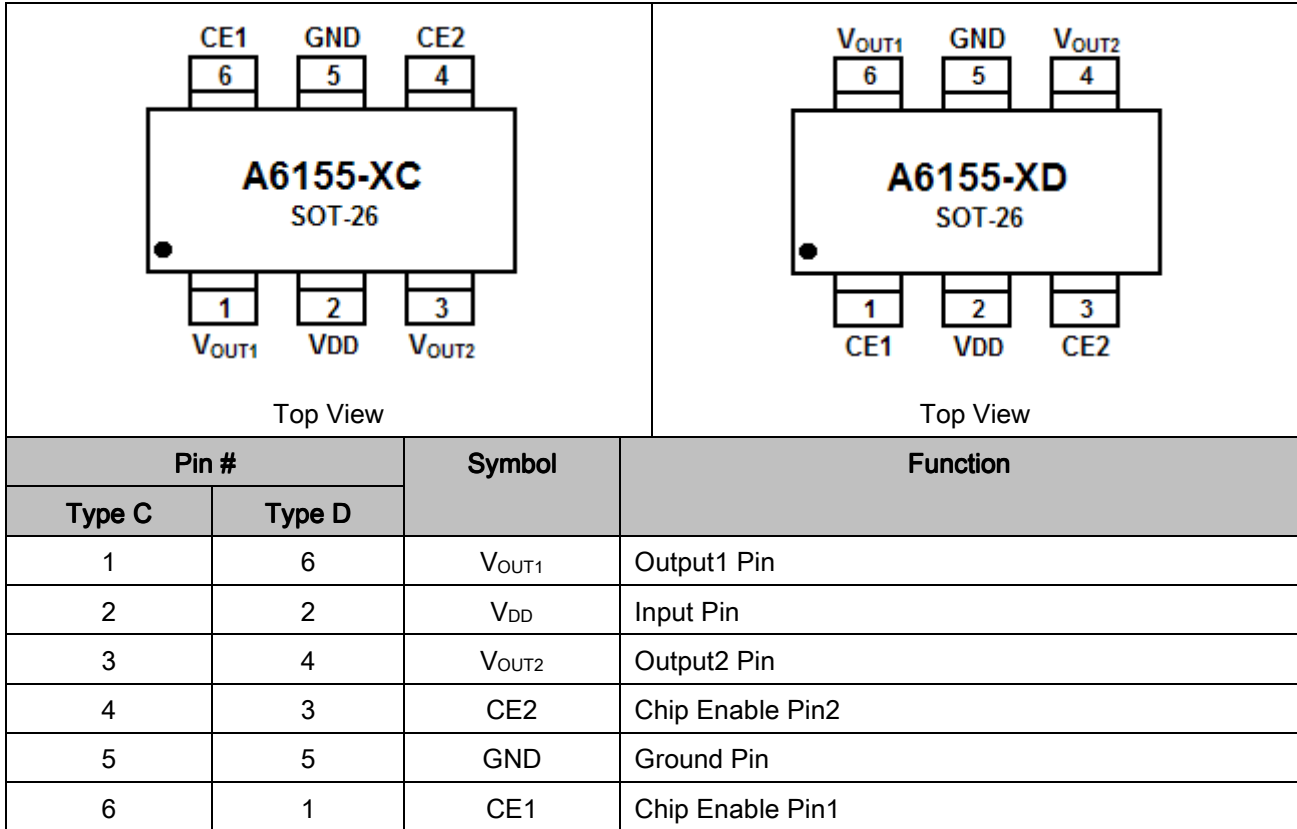



OUTPUT VOLTAGE PORTFOLIO

Output Voltage			Part Number		Output Voltage			Part Number	
Code	V ₁	V ₂	Type C	Type D	Code	V ₁	V ₂	Type C	Type D
A	1.5	2.5	A6155E6-AC	A6155E6-AD	M	2.8	1.8	A6155E6-MC	A6155E6-MD
B	1.5	2.8	A6155E6-BC	A6155E6-BD	N	2.8	2.5	A6155E6-NC	A6155E6-ND
C	1.5	3.0	A6155E6-CC	A6155E6-CD	O	2.8	2.8	A6155E6-OC	A6155E6-OD
D	1.5	3.3	A6155E6-DC	A6155E6-DD	P	2.8	3.0	A6155E6-PC	A6155E6-PD
E	1.5	4.0	A6155E6-EC	A6155E6-ED	Q	3.0	2.5	A6155E6-QC	A6155E6-QD
F	1.8	1.8	A6155E6-FC	A6155E6-FD	R	3.0	3.0	A6155E6-RC	A6155E6-RD
G	1.8	2.5	A6155E6-GC	A6155E6-GD	S	3.0	3.3	A6155E6-SC	A6155E6-SD
H	1.8	2.8	A6155E6-HC	A6155E6-HD	T	3.3	1.8	A6155E6-TC	A6155E6-TD
I	1.8	3.0	A6155E6-IC	A6155E6-ID	U	3.3	2.5	A6155E6-UC	A6155E6-UD
J	1.8	3.3	A6155E6-JC	A6155E6-JD	V	3.3	2.8	A6155E6-VC	A6155E6-VD
K	2.5	1.8	A6155E6-KC	A6155E6-KD	W	3.3	3.3	A6155E6-WC	A6155E6-WD
L	2.5	2.5	A6155E6-LC	A6155E6-LD	X	2.8	1.5	A6155E6-XC	A6155E6-XD

ABSOLUTE MAXIMUM RATINGS

Max Input Voltage	10V
Junction Temperature(T _J)	125°C
Output Current	200mA
Power Dissipation (SOT-26)	200mW
Storage Temperature (T _s)	-45°C~150°C
Lead Temperature and Time	260°C, 10S

Stresses beyond may cause permanent damage to the device. These are stress ratings only and functional operation of the device at these or any other conditions beyond those indicated in the Electrical Characteristics are not implied. Exposure to absolute maximum rating conditions for extended periods may affect device reliability.



ELECTRICAL CHARACTERISTICS

Test Conditions: C1=1uF, C2=C3==2.2uF, TA=25°C, unless otherwise specified.

Symbol	Parameter	Conditions	Min	Typ	Max	Unit
V _{IN}	Input Voltage		1.5		8	V
V _{OUT}	Output Voltage	V _{IN} =Set V _{OUT} +1V 1mA≤I _{OUT} ≤30mA	V _{OUT} x0.98		V _{OUT} x1.02	V
I _{OUT} (Max)	Max Output Current	V _{IN} -V _{OUT} =1V	150			mA
Dropout Voltage	Input-Output Voltage Differential	Refer to the Electrical Characteristics by output voltage				
$\frac{\Delta V_{OUT}}{\Delta V_{IN} \times V_{OUT}}$	Line Regulation	I _{OUT} =40mA 1.6V≤V _{IN} ≤8V		0.05	0.2	%/V
$\Delta V_{OUT}/\Delta I_{OUT}$	Load Regulation	V _{IN} =Set V _{OUT} +1V 1mA≤I _{OUT} ≤80mA		12	40	mV
I _{SS}	Supply Current	V _{IN} =Set V _{OUT} +1V		25	50	uA
I _{STANDBY}	Supply Current (Standby)	V _{IN} =Set V _{OUT} +1V, V _{CE} =GND		0.1	1.0	uA
$\frac{\Delta V_{OUT}}{\Delta T \times V_{OUT}}$	Output Voltage Temperature Coefficiency	I _{OUT} =30mA		±100		ppm/°C
PSRR	Ripple Rejection	F=1KHz, Ripple=0.5Vp-p V _{IN} =Set V _{OUT} +1V		65		dB
I _{LIM}	Short Current Limit	V _{OUT} =0V		20		mA
R _{pd}	CE Pull down Resistance		2.0	5.0	10.0	mΩ
V _{CEH}	CE Input Voltage "H"		1.5		V _{IN}	V
V _{CEL}	CE Input Voltage "L"		0		0.25	V
en	Output Noise	BW=10Hz~100KHz		27		uV _{RMS}

ELECTRICAL CHARACTERISTICS BY OUTPUT VOLTAGE

Output Voltage V _{OUT} (V)	Dropout Voltage, V _{DIF} (V)		
	Condition	Typ.	Max
V _{OUT} =1.5V	I _{OUT} =120mA	0.38	0.70
V _{OUT} =1.6V		0.36	0.65
V _{OUT} =1.7V		0.34	0.60
1.8V≤V _{OUT} ≤2.0		0.32	0.55
2.1V≤V _{OUT} ≤2.7		0.28	0.60
2.8V≤V _{OUT} ≤4.0		0.22	0.35



TYPICAL PERFORMANCE CHARACTERISTICS

1. Output Voltage vs. Output Current
(with output short protection) Output: 1.8V

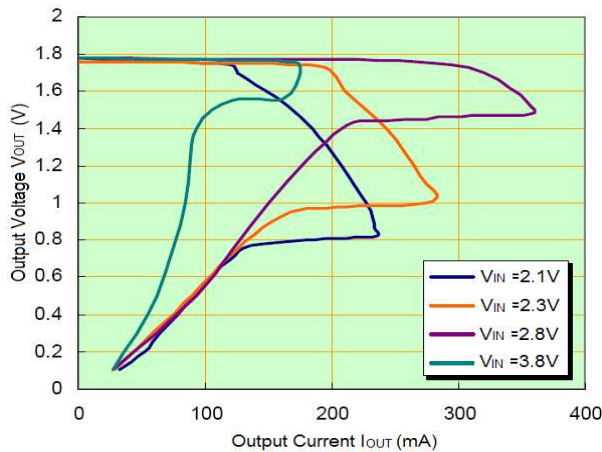

2. Output Voltage vs. Input Voltage
Output: 1.8V

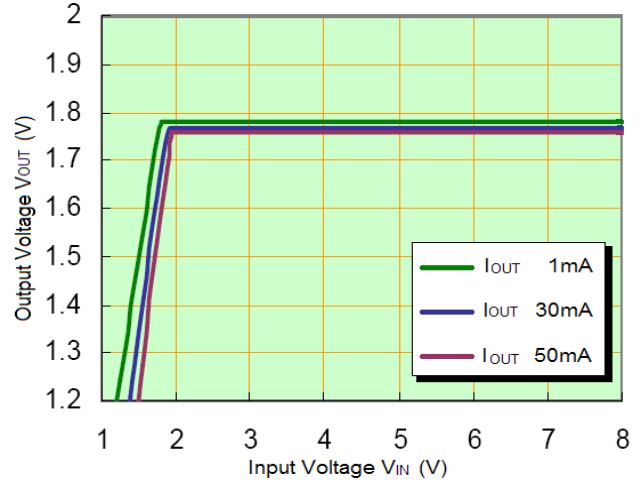

3. Dropout Voltage vs. Output Current

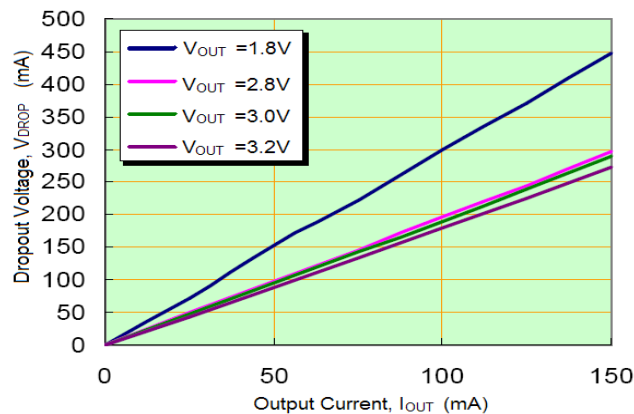

4. Supply Current vs. Input Voltage
Output: 1.8V

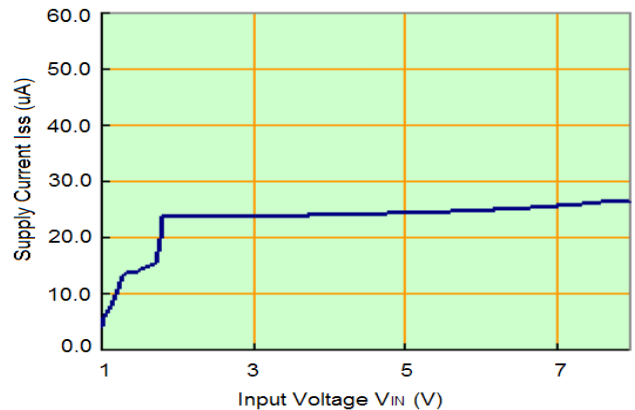

5. Ripple Rejection vs. Frequency

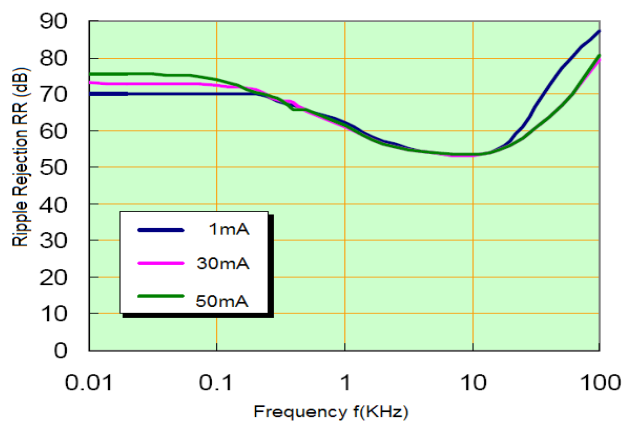

6. Line Transient Response

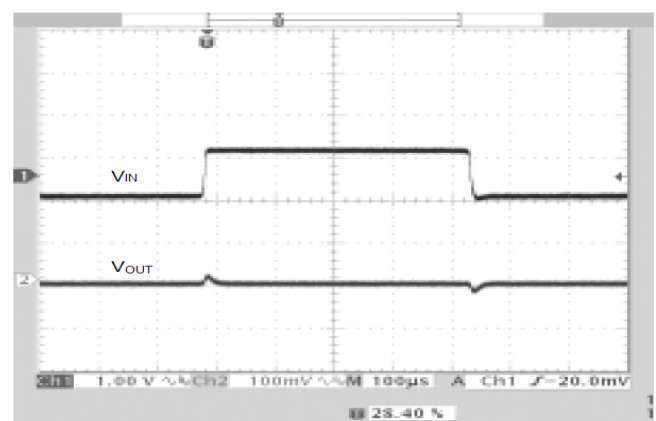



7. Load Transient Response

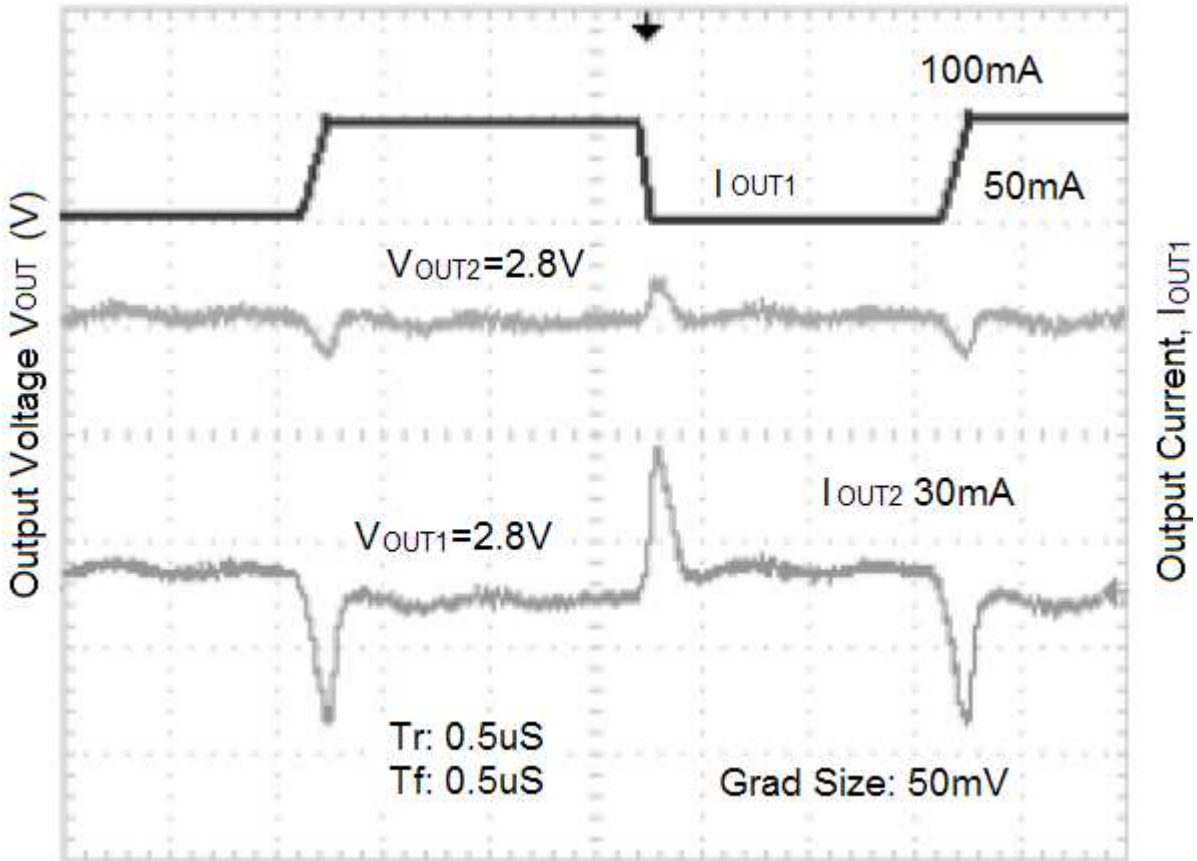



BLOCK DIAGRAM

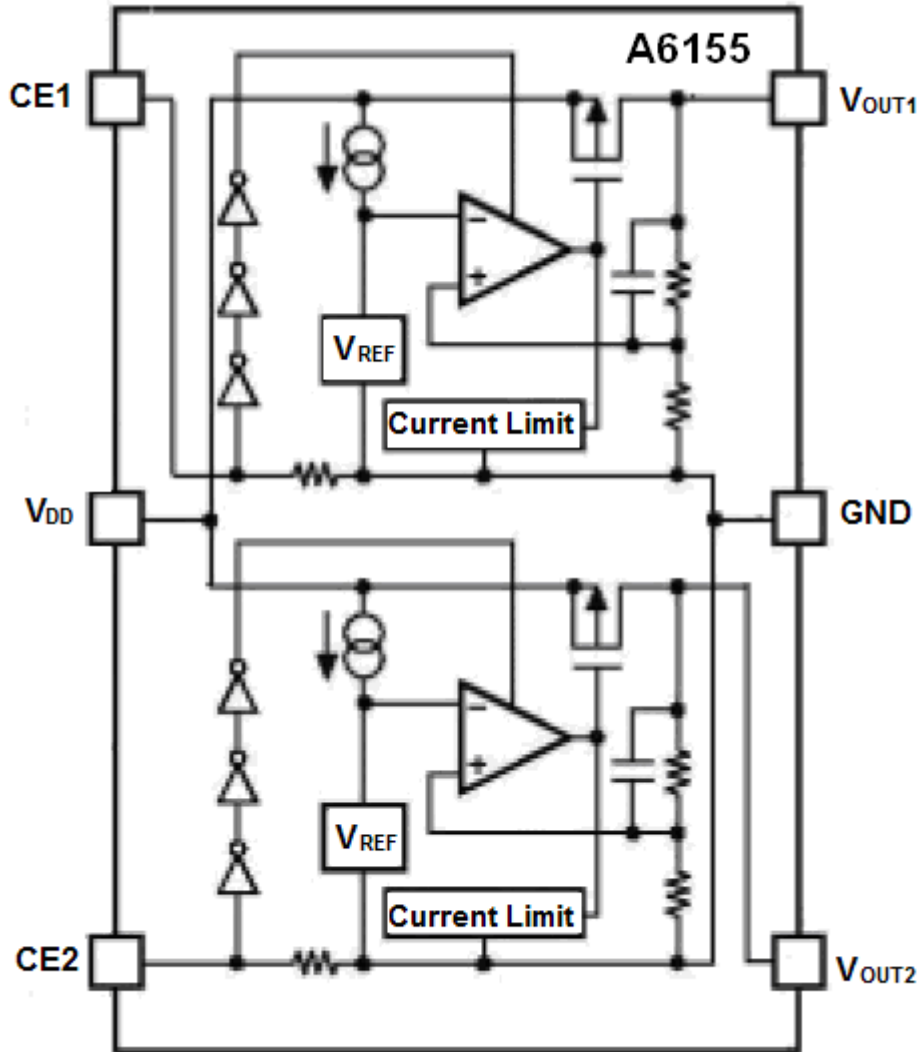



DETAILED INFORMATION

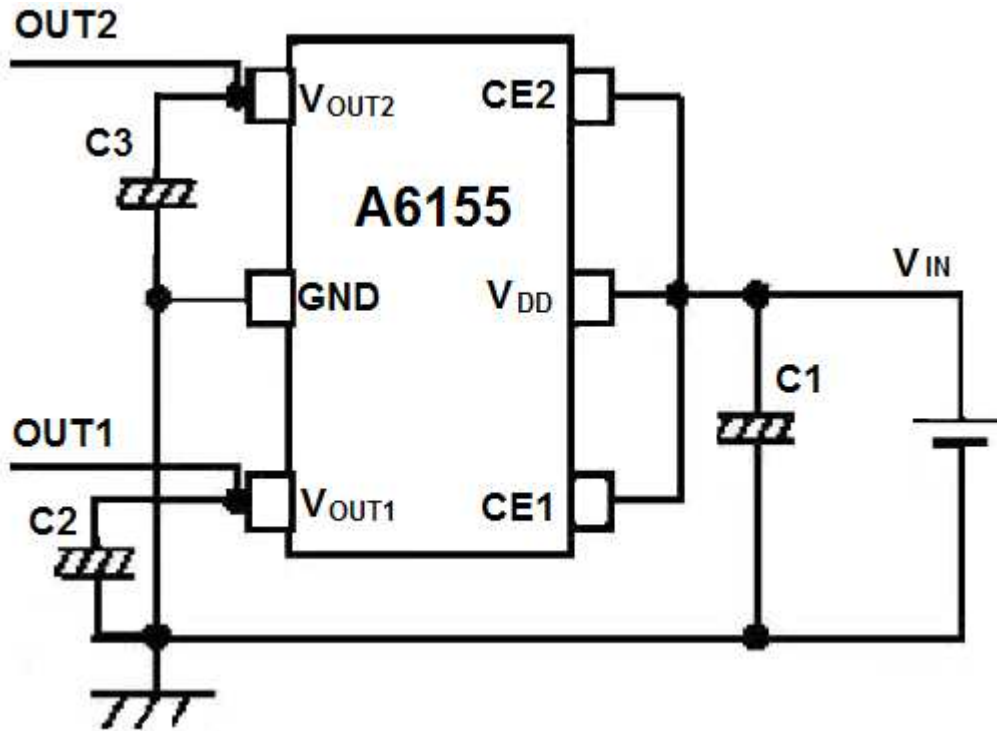

Input Capacitor (C1=1uF) is recommended in all application circuit.

Output Capacitor (C2=C3=1uF/2.2uF) is recommended in all application to assure the stability of circuit.

1.8V output circuit

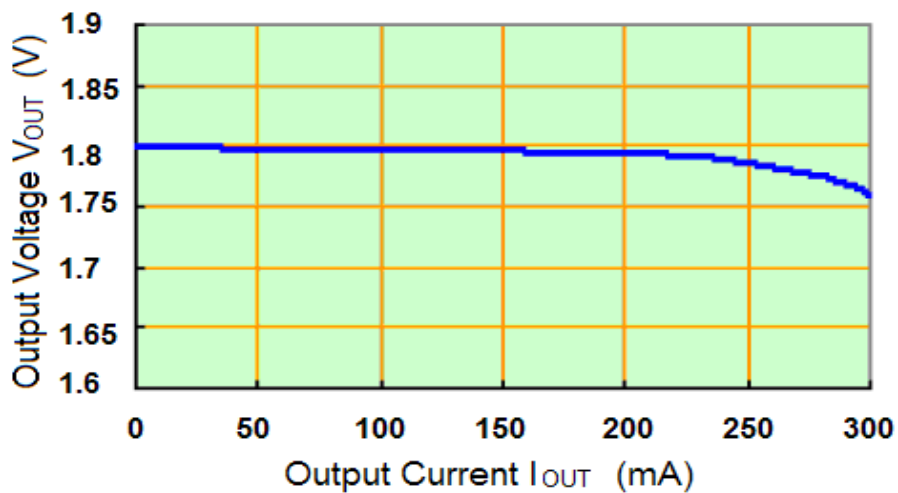



PACKAGE INFORMATION

Dimension in SOT-26 Package (Unit: mm)

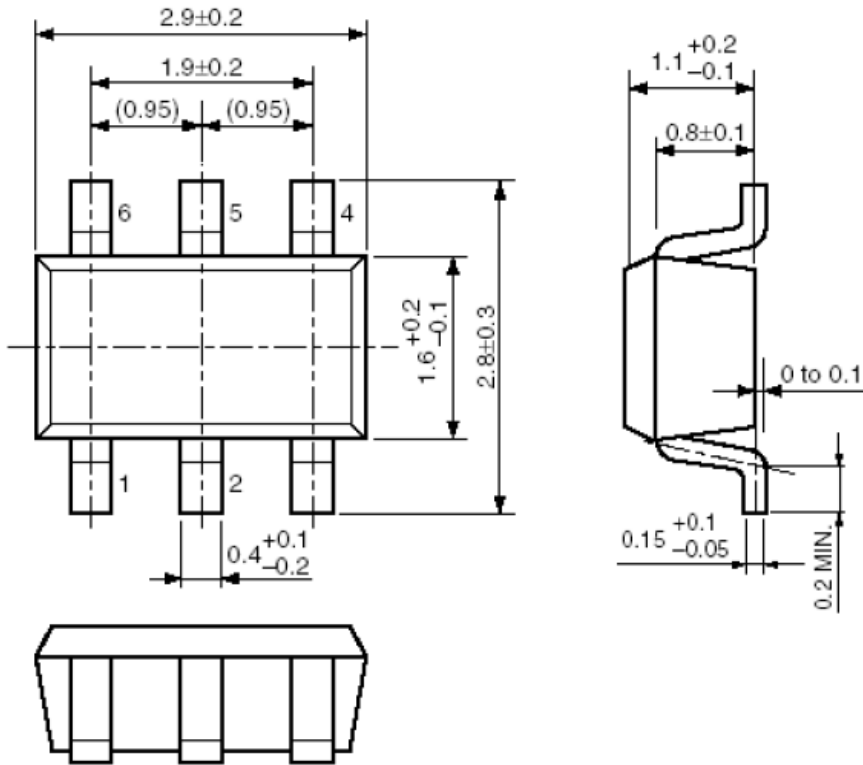

Tape Dimension

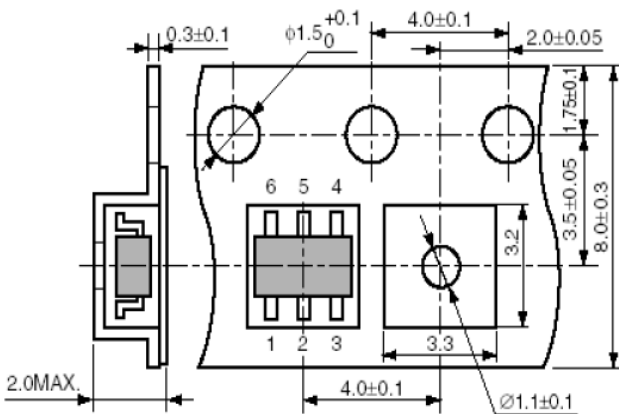

Reel Dimension

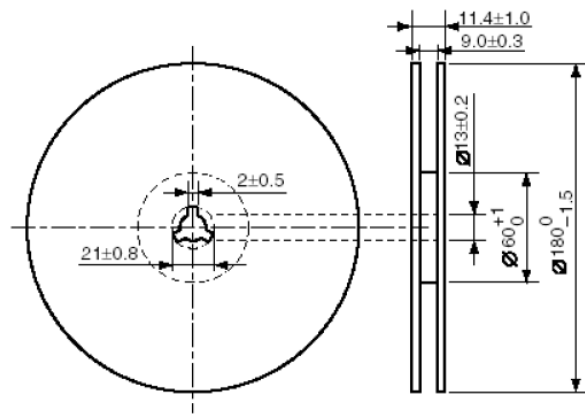



IMPORTANT NOTICE

AiT Semiconductor Inc. (AiT) reserves the right to make changes to any its product, specifications, to discontinue any integrated circuit product or service without notice, and advises its customers to obtain the latest version of relevant information to verify, before placing orders, that the information being relied on is current.

AiT Semiconductor Inc.'s integrated circuit products are not designed, intended, authorized, or warranted to be suitable for use in life support applications, devices or systems or other critical applications. Use of AiT products in such applications is understood to be fully at the risk of the customer. As used herein may involve potential risks of death, personal injury, or severe property, or environmental damage. In order to minimize risks associated with the customer's applications, the customer should provide adequate design and operating safeguards.

AiT Semiconductor Inc. assumes to no liability to customer product design or application support. AiT warrants the performance of its products of the specifications applicable at the time of sale.